

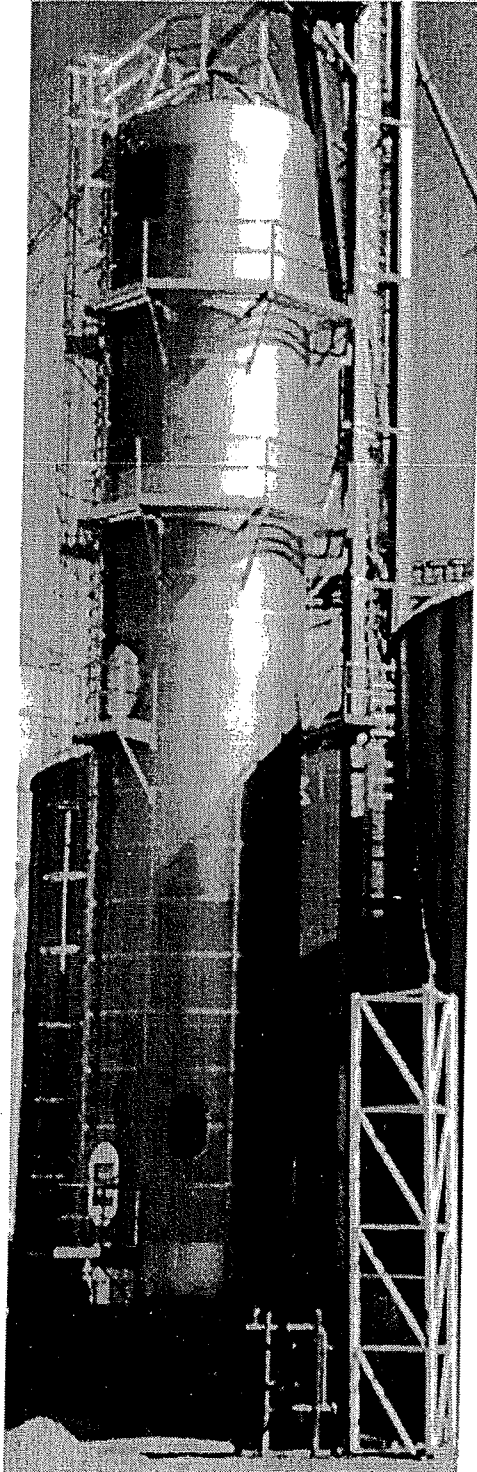

# TOWER DRYER



## MODEL 2000 & 2250

12 ft. (3.66m.) Diameter  
Starting with S/N 58406

## OPERATOR'S MANUAL

Form No. TD397  
July 2005

**Mathews Company**

500 Industrial Avenue  
P.O. Box 70, Crystal Lake IL 60039-0070 U.S.A.  
Phone: 815/459-2210 ♦ Fax: 815/459-5889  
[www.mathewscompany.com](http://www.mathewscompany.com)



### Safety Precautions:

A trained electrician should do all electrical work. When electrical work is being done, the main disconnect should be locked and tagged out. Disconnect all electrical power before servicing or opening control box, adjusting, or lubricating the equipment.

In accordance with your local area, you must have the proper qualified person work on plumbing. When working on plumbing, you must lock and tag out fuel supply line. Fuel line must be drained and shut off before servicing. Some regulations specify that no one under the age of 16 may operate power machinery. This includes farmstead equipment.

OSHA regulations state in part: "At the time of initial assignment and at least annually thereafter, the employer shall instruct every employee in the safe operation and servicing of all equipment with which the employee is, or will be involved."

Unqualified persons are to stay out of the work area. The "work area" is defined as any area within the grain drying and storage complex where this equipment is installed.

A person who has not read and does not understand all operating and safety instructions is not qualified to operate the machine.

**NEVER WORK AROUND THE DRYER WITH CONTROLS ON.**  
Dryer has automatic controls and will turn on and off without warning! Stay clear of motors, belts, pulleys, sprockets, and AUGERS.

**Failure to follow these instructions may result  
in personal injury or property damage.**



# INTRODUCTION

## To the Owner-Operator

This manual was prepared to provide owners and operators of the M-C Model 2000 and 2250 Grain Dryer (starting with serial number 58406) with Operating Instructions and Maintenance Information that will enable them to keep their M-C Grain Dryer operating at peak efficiency.

Before operating your Grain Dryer read the Start-Up and Operating Instructions. Check each item referred to and become familiar with the controls, adjustments and settings required to obtain efficient operation.

To keep the dryer operating at peak efficiency it is suggested that it be cleaned, lubricated, belt tension adjusted and the ignition system, level auger and unloading system be tested each year prior to the dryer season. Refer to "Pre-Season Check" in the Maintenance section. The pre-season check can be made when the dryer is empty. Any necessary repairs or adjustments can be made so that the dryer will be ready to operate before the drying season.

## Safety Precautions



This symbol is used to call your attention to instructions concerning your personal safety. Be sure to observe and follow these instructions.

A safe operator is the best insurance against accidents. The precautions listed below must be observed at all times.

- Do not allow children or bystanders to be near the Grain Dryer or grain handling machinery while it is operating.
- Do not operate the Grain Dryer without all safety shields in place and secure.

**NOTE:** To provide clear illustrations some of the covers, guards and shields were removed.

## Warranty Registration

It is important to send in your warranty registration card as soon as your new Grain Dryer is delivered. Not only does the card validate your Grain Dryer warranty, but it is also our way of knowing who has purchased M-C equipment so that we can keep in touch with you.

M-C GRAIN DRYER			
MODEL	CONTROL VOLTAGE	SERIAL NUMBER	
VOLTAGE	PHASE	HZ	MAX. OPERATING AMPS
TOP BLOWER MOTOR HP			RPM
MIDDLE BLOWER MOTOR HP			RPM
MIDDLE BLOWER MOTOR HP			RPM
MIDDLE BLOWER MOTOR HP			RPM
MIDDLE BLOWER MOTOR HP			RPM
LOWER BLOWER MOTOR HP			RPM
TOP AUGER MOTOR HP			RPM
LOWER AUGER MOTOR HP			RPM
FUEL	NATURAL GAS	LIQUID PROPANE	
MAXIMUM ALLOWABLE SUPPLY PRESSURE			PSI
MAXIMUM INPUT			
MINIMUM INPUT			
REQUIRED MINIMUM SUPPLY PRESSURE FOR MAXIMUM INPUT			PSI
REQUIRED MINIMUM SUPPLY PRESSURE FOR MINIMUM INPUT			PSI
MANIFOLD PRESSURE AT MAXIMUM INPUT			PSI
MANIFOLD PRESSURE AT MINIMUM INPUT			PSI
PLENUM STATIC PRESSURE FROM 1/2 to 6 INCHES, W.C.			
MINIMUM CLEARANCE TO COMBUSTIBLE CONSTRUCTION - 4 FEET			
WARNING - FOR OUTDOOR INSTALLATION ONLY			
DESIGN TESTED TO CAN/CGA-3.8 STANDARD			
MATHEWS COMPANY 500 INDUSTRIAL DR. CRYSTAL LAKE, IL U.S.A. PRODUCTION DATE			
SÉCHOIR À GRAINS M-C			
MODÈLE	TENSION DE COMMANDE	NUMÉRO DE SÉRIE	
TENSION	PHASE	HZ	INTENSITÉ NOMI DE FONCTIONNEMENT
PUISSANCE DU MOTEUR DE LA SOUFFLEUSE DU HAUT			TR/MIN
PUISSANCE DU MOTEUR DE LA SOUFFLEUSE DU MILIEU			TR/MIN
PUISSANCE DU MOTEUR DE LA SOUFFLEUSE DU MILIEU			TR/MIN
PUISSANCE DU MOTEUR DE LA SOUFFLEUSE DU MILIEU			TR/MIN
PUISSANCE DU MOTEUR DE LA SOUFFLEUSE DU MILIEU			TR/MIN
PUISSANCE DU MOTEUR DE LA SOUFFLEUSE DU BAS			TR/MIN
PUISSANCE DU MOTEUR DE LA VIS SANS FIN DU HAUT			TR/MIN
PUISSANCE DU MOTEUR DE LA VIS SANS FIN DU BAS			TR/MIN
CARBURANT	GAZ NATUREL	PROPANE LIQUIDE	
PRESSION D'ALIMENTATION ADMISSIBLE MAXIMALE			LIVRES PAR POUCE CARRÉ (PSI)
PUISSANCE D'ENTRÉE MAXIMALE			
PUISSANCE D'ENTRÉE MINIMALE			
PRESSION D'ALIMENTATION MINIMALE REQUISE POUR OBTENIR LA PUISSANCE D'ENTRÉE MAXIMALE			PSI
PRESSION D'ALIMENTATION MINIMALE REQUISE POUR OBTENIR LA PUISSANCE D'ENTRÉE MINIMALE			PSI
PRESSION D'ADMISSION À LA PUISSANCE D'ENTRÉE MAXIMALE			PSI
PRESSION D'ADMISSION À LA PUISSANCE D'ENTRÉE MINIMALE			PSI
PRESSION STATIQUE DE LA CHAMBRE DE RÉPARTITION D'AIR D'1/2 À 6 POUÇES (DE 12,7 À 152,4 mm), CE			
DÉGAGEMENT MINIMAL ENTRE LE SÉCHOIR ET TOUTE STRUCTURE COMBUSTIBLE : 4 PIEDS (122 cm)			
AVERTISSEMENT : POUR INSTALLATION EN EXTÉRIEUR UNIQUEMENT			
CONCEPTION TESTÉE POUR ÊTRE CONFORME À LA NORME CAN/CGA-3.8			
MATHEWS COMPANY 500 INDUSTRIAL DR. CRYSTAL LAKE, IL ÉTATS-UNIS DATE DE PRODUCTION			

Figure A

## Model and Serial Number Location

The model, serial number and specifications of your Mathews Company Continuous Flow Grain Dryer are stamped on plates (English and French) that are located on the left front base panel shown in Figure A. For future reference record the model and serial number in the blank spaces of the plate shown in Figure B.

# REMOTE CABINET BUTTONS, DIALS, LIGHTS, METERS, & SWITCHES

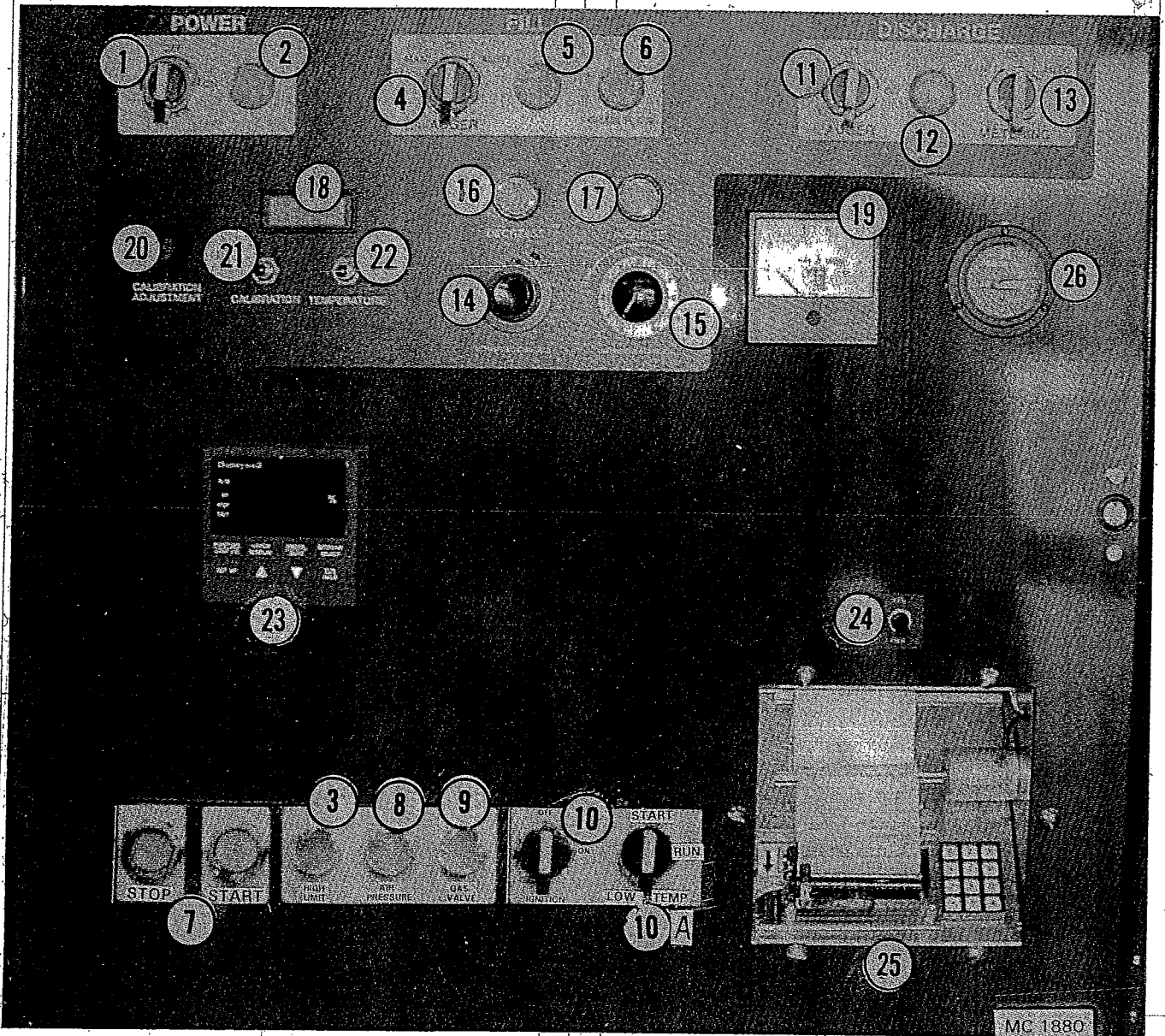

## Ref. 1. - Power On Switch

When this spring loaded switch is turned to the ON position, the power on light will be on if the rear discharge overload door is closed, all magnetic starter overload relay blocks are closed, and the relay is activated. High limit lights will also be on. If not, push the reset button on the high limit switch.

**NOTE:** If there is a momentary loss of electricity, the dryer will shut down and the dryer will have to be restarted by turning power on switch to the ON position again.

## Ref. 2 - Power On Light

Indicates power on switch has been turned on, discharge overload door and starter overloads are closed, and dryer relay is activated.

## Ref. 3 - High Limit Light

Indicates power switch has been turned on and high limit switch is closed.

## Ref. 4 - Wet Grain Fill Switch

When switch is in the MANUAL position, the wet hopper fill equipment will start immediately

when the rotary FILL switch in the hopper signals for grain and stops when the hopper is full.

When the switch is in the AUTOMATIC position, the rotary FILL switch will start the fill equipment automatically after the preset time on the delay and stop fill equipment when hopper is full.

#### **Ref. 5 – Fill Light**

Indicates that the grain level in the hopper is low and the rotary FILL switch in the hopper has closed activating the customer supplied fill equipment.

#### **Ref. 6 – Grain Flow Light**

Indicates low grain level in wet hopper. Light comes on when Grain Flow Timer reaches zero and dryer is shut down.

#### **Ref. 7 – Fan Start-Stop Buttons**

Green Button starts and Red Button stops the fan.

#### **Ref. 8 – Air Pressure Light**

Indicates that the air pressure switch is closed, the fan motor magnetic starter is engaged, and the dryer is full of grain.

#### **Ref. 9 – Gas Valve Light**

Indicates ignition board terminal V1 is powered to open solenoid valves for burner ignition. Light remains lit as long as flame sense probe continues sensing burner flame and terminal V1 is powered. If sensing is lost, board will lockout and shut down solenoid valves and gas valve light.

#### **Ref. 10 – Burner Ignition Switch OFF/ON**

Turn this switch to ON position to ignite the Burner. After a (10) second delay, Ignition Board terminal V1 is energized to open gas solenoids for burner ignition. Gas Valve Light will also be energized. If Burner does not ignite in (10) seconds, Ignition Board will lock out, de-energizing the gas solenoid valves and gas valve light. Switch will have to be turned to OFF then back to ON for another try at burner ignition.

#### **Ref. 10A – Low Temp Shutdown Switch-Start/Run**

Activates thermostat that monitors air temperature in heat chamber. When temperature drops below setting on thermostat, dryer shuts down. Always start dryer with switch in the START position. Once heat chamber reaches drying temperature, turn switch to the RUN position.

#### **Ref. 11 – Discharge (Unload) Auger Switch**

Turn this spring loaded switch to the ON position to start discharge auger. If there is a momentary loss of electricity, the dryer will shut down and the dryer will have to be restarted.

If the discharge auger was operating when the dryer shut down, the Discharge Switch will have to be turned to the ON position again to start the auger.

#### **Ref. 12 – Discharge Auger Light**

Indicates that the discharge sweep and auger are operating.

#### **Ref. 13 – Discharge Metering Switch**

When the switch is turned to the MANUAL position, the AC drive motor will run constantly and the speed of the sweep and discharge auger will be controlled by the Manual Drive Speed Control Dial.

When this switch is in the AUTOMATIC position, the Moisture Control Board will speed up or slow down the AC motor automatically.

#### **Ref. 14 – Manual AC Drive Speed Control**

This manual speed control is used to adjust the speed of the AC motor that drives the grain sweep and discharge auger and changes discharge speed when discharge metering switch (Ref. 13) is in the MANUAL POSITION only. Be sure to disengage lock before turning dial.

# REMOTE CABINET BUTTONS, DIALS, LIGHTS, METERS, & SWITCHES

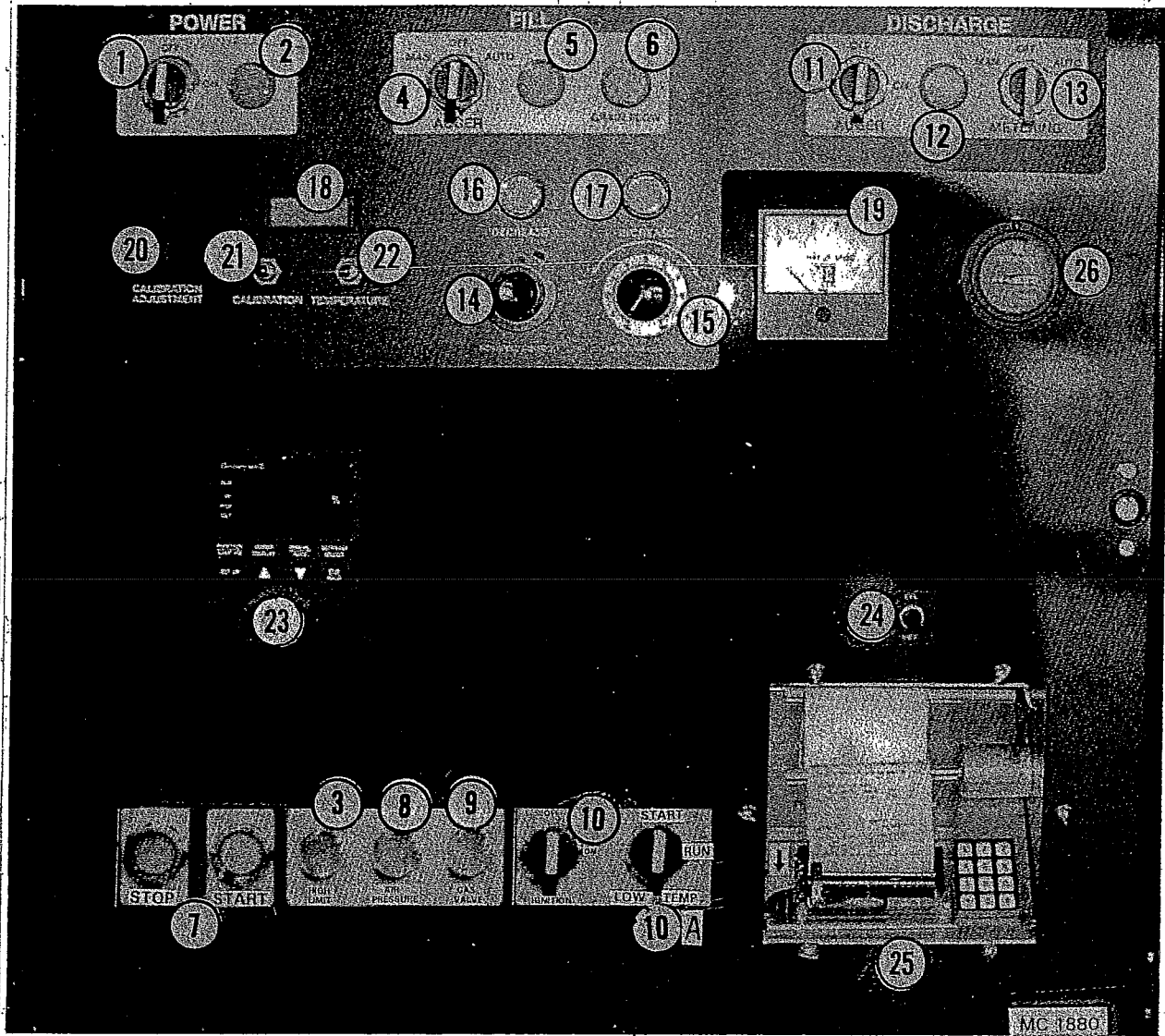

**Ref. 15 – Moisture Control Balance Dial**

This balance dial is used to equalize the Moisture Control Decrease and Increase Indicator Lights before turning the discharge metering switch to AUTOMATIC.

Once in AUTOMATIC the dial is used to make small adjustments in the moisture content of the discharged grain.

**Ref. 16 – Moisture Control Decrease Light**

Indicates that the discharge rate is decreasing if Moisture Control is in AUTOMATIC.

**Ref. 17 – Moisture Control Increase Light**

Indicates that the discharge rate is increasing if Moisture Control is in AUTOMATIC.

**Ref. 18 – Digital Display Meter**

Displays discharge grain moisture constantly, grain temperature and calibration setting when respective display button is pushed.

**Ref. 19 – Discharge Meter**

Indicates the rate of discharge when discharge metering switch is in MANUAL or AUTOMATIC.

**Ref. 20 – Calibration Adjustment Dial**

Turn dial to change calibration.

**Ref. 21 – Calibration Display Button**

Push button to display amount added or subtracted (-9.9 to +9.9) from the discharge grain moisture shown on the digital display meter (23).

**Ref. 22 – Temperature Display Button**

Push button to display temperature of grain moving over Sensor.

**Ref. 23 – Temperature Controller**

Controls the Modulating Valve that regulates the amount of gas supplied to the Burner. Digital Display shows temperature and percent that modulating valve is open.

**Ref. 24 – Printer ON/OFF Switch**

Turns printer on or off.

**Ref. 25 – Printer**

Provides printed record of time, day, discharge grain moisture, temperature, and average moisture content.

**Ref. 26 – Hour Meter**

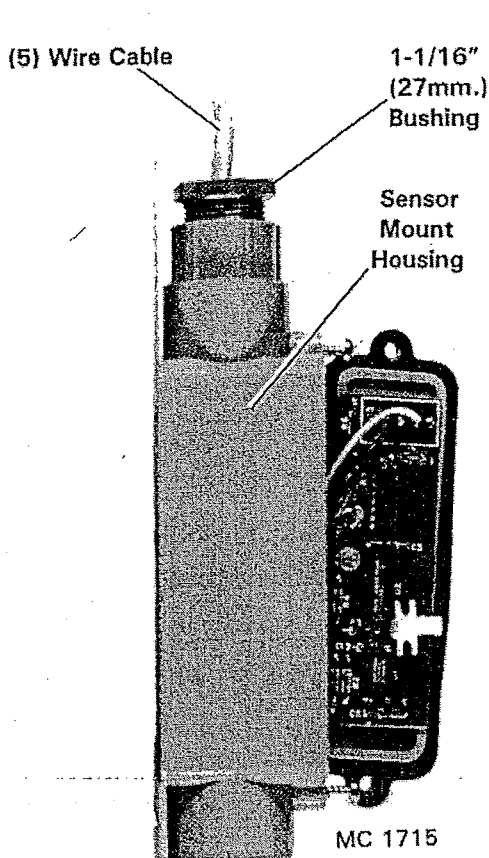

**Figure 10 - Weather Sensor**

A Weather Sensor is supplied with the Printer but must be installed by customer when dryer installation is completed, see Figure 10.

The Weather Sensor is not required for the proper operation of the Monitor or Printer.

It is recommended that the Sensor be located about (20) ft. (6.1m.) from the heat and humidity of the dryer.

There are (5) colored wires connected to the Weather Sensor Circuit Board that will have to be connected to the (36) Pin Black Connector (Number Side) that is attached to the top of the Monitor and Printer Interface Board Holder in the Control Cabinet. The (5) wires are:

- White to terminal 11,
- Black to terminal 10,
- Brown to terminal 9,
- Green to terminal 8, and
- Red to terminal 7.

If the Remote Cabinet is a sufficient distance from the heat and humidity produced by the dryer, the Weather Sensor can be mounted to the outside bottom of the Remote Cabinet.

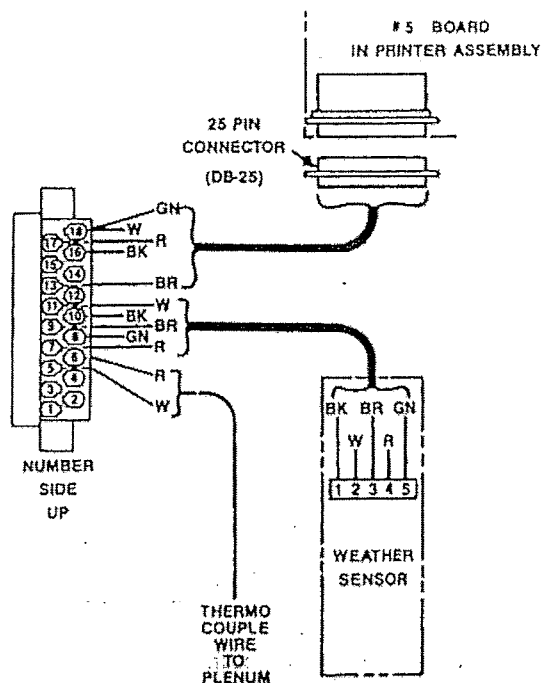

**Figure 11**

A 1-3/32" (27.8mm.) diameter hole will have to be drilled in the bottom of the Remote Cabinet. The special 1-1/16" (27mm.) threaded bushing is then placed into the hole with the thread end to the bottom.

The (5) wire cable from the Sensor Board is pulled up through the bushing and the Mount Housing is secured to the bottom of the cabinet by turning the bushing into the mount housing until tight. Now place the (5) wires listed above into their correct terminals and tighten, see Figure 11.

If the Remote Cabinet is located too close to the dryer, a location away from the dryer is recommended (about 20 ft. (6.1m.) if possible. Once a suitable location is selected, secure the Weather Sensor Mount Housing.

A length of (5) wire cable will probably have to be spliced and soldered to the 8 ft. (2.44m.) cable supplied with the Weather Sensor to reach the distance selected from the dryer. Be sure to allow 36" (92cm.) from the bottom of the remote cabinet to the (36) Pin Black Connector at the top inside of the cabinet. See Figure 11.

The (5) wire cable should be placed into a separate 3/8" (9.5mm.) flexible liquidite conduit or a 1/2" (12.7mm.) metal conduit from Sensor Mount Housing to the bottom of the Control Cabinet. No high voltage (115V) wires are to be placed in same conduit as the (5) low voltage Sensor wires.



## Moisture Monitor and Printer

As soon as electric power is supplied to dryer, the Moisture Monitor and Printer will be activated. The Printer is equipped with an on and off switch to control its operation.

### Moisture Monitor Instructions

- A. The Digital Display Meter shows grain moisture constantly and should read approximately 6% when Sensor is in open air (no grain passing over Sensor), see Figure 8.
- B. Push Grain Temperature Button and the display meter will show Temperature of Grain on the sensor, see Figure 8.
- C. Push Calibration Button and the display meter will show the amount added to or subtracted from the displayed moisture (-9.9 to +9.9), see Figure 8.

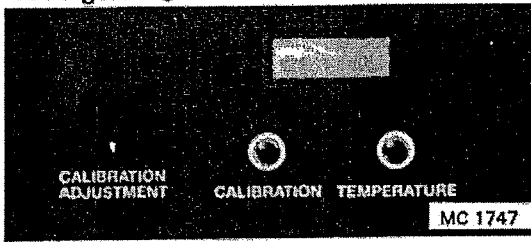

Figure 8

- D. The Moisture Monitor may need to be calibrated to compensate for different grains and sensor configurations. Make sure that the calibration is set at zero before comparing the displayed moisture values with the samples tested with a reliable moisture tester. See Figure 9, Moisture Monitor Sampling Chart.

1. If the displayed moisture value is less than from a moisture tester, push the "Display Calibration" and turn the calibration knob to display the actual difference (+ Value).
2. If the displayed moisture value is more than from the moisture tester value, push the "Display Calibration" and turn the calibration knob to display the actual difference with a minus sign (- Value).



**CAUTION:** Use a safe sampling procedure. Do not sample from a hopper with an unguarded auger. Keep hands, feet and clothing away from rotating parts.

3. The following sampling guidelines are recommended:

- a. Take samples when the displayed moisture values are not changing rapidly.
- b. Observe the moisture display when the sample is taken. Record both the displayed values and tested values for at least six (6) samples and take the average of each.
- c. Take samples from the Grain Sampler located on the left side of the Unload (Discharge) Auger Box, see Figure

**Question:** Where would you set the moisture offset, +0.3 or 0.6?

**Answer:** Most would want to set it to +0.3 which would make it match the point of sale's moisture reading.

Moisture Monitor Sampling					
The chart shows grain moisture readings (from a real situation) as they should be taken to obtain a realistic moisture value.					
Time	M-C Monitor		Dole		Elevator
	Temp.	Moisture	Temp.	Corrected Moisture	Moisture
9:33AM	112	14.4%	109	14.7%	
9:36AM	112	14.4%	111	14.4%	
9:38AM	108	16.0%	107	17.5%	
9:40AM	110	14.6%	109	14.7%	
9:43AM	108	15.9%	104	17.3%	
9:50AM	111	14.5%	107	15.0%	
Total		89.8%		93.6%	
Average		15.0%		15.6%	15.3%

Figure 9

### Printer

The printer provides a printed record of:

1. Time.
2. Mode.
3. Grain Discharge Moisture.
4. Grain Discharge Temperature.
5. Ambient Temperature from Weather Station.
6. Average Discharge Moisture.
7. Relative Humidity from Weather Station.
8. Calibration (Moisture Offset).
9. Bin # that is being filled with dry grain.

# PRINTER DEFINITIONS

## Printer Module and Printout

A "COLD START" OCCURS WHEN BATTERIES ARE NOT INSTALLED OR ARE WEAK AND NEED REPLACING (APPROXIMATELY EVERY 2 YEARS).

THIS DATA NEEDS TO BE ENTERED FOR OPERATION.

IF ENTRY IS NOT ACCEPTED THE QUESTION IS REPEATED.

ACCEPTABLE NUMBER INPUTS ARE:

MM = MONTH 01 THRU 12  
 DD = DAY 01 THRU 31  
 YY = YEAR 00 THRU 99  
 HH = HOUR 01 THRU 12  
 MM = MINUTE 01 THRU 60

PRINTS OUT YOUR ENTERED INFORMATION.

AUTOMATICALLY SET AT FIVE MINUTES. CAN BE SET FROM TWO MINUTES THRU 30 MINUTES.

AUTOMATICALLY SET AT "1", CAN BE NUMBERED UP TO 999.

COLD START - CHECK BATTERIES  
 ENTER THE DATE MMDDYY  
 DAY? - SUN=1 M=2 T=3 W=4 T=5 F=6 SAT=7  
 ENTER THE TIME HHMM (12 HR FORMAT)  
 ENTER 0 FOR AM OR 1 FOR PM  
 DATE THURSDAY 08-17-89 TIME 08:36A  
 ENTER 0 TO CHANGE OR # TO ACCEPT  
 CURRENT INTERVAL IS 5 MINUTES  
 ENTER 2-DIGITS OR # TO ACCEPT  
 CURRENT BIN IS # 1  
 ENTER 3 DIGIT NUMBER OR # TO ACCEPT

## PRINTER DEFINITIONS (continued)

MENU IS PRINTED WHEN ANY KEY IS PUSHED.

DATA ENTERED AT COLD START. BATTERY BACKUP, EVEN WITH POWER LOSS.

ENTER IF OTHER GRAIN IS RUN:

"1" - CORN  
 "2" - MILO  
 "3" - RICE  
 "4" - WHEAT  
 "5" - SOYBEANS  
 "6" - SUNFLOWER  
 "7" - OTHER

GRAIN TYPE? - CORN=1 MILO=2 RICE=3  
 WHEAT=4 SOYBEAN=5 SUNFLOWER=6 OTHER=7  
 DATE THURSDAY 08-17-89 TIME 08:54A  
 1 TO BEGIN PERIODIC READOUT  
 2 TO CHANGE PRINT INTERVAL--NOW 5 MIN.  
 3 TO AVERAGE---BEGAN 08-17-89 AT 08:36A  
 4 TO CHANGE BIN NUMBER--NOW 1  
 5 TO CORRECT DATE/TIME  
 6 TO CHANGE GRAIN TYPE--NOW CORN

FROM WEATHER STATION INPUT AT TIME OF PRINTING. READS "0" WHEN NOT HOOKED UP.

HEADER ALWAYS PRINTED AFTER MENU, EVERY TWO HOURS OF RUNNING TIME, MOISTURE LIMIT CHANGE, AND MOISTURE OFFSET CHANGE.

ANY TIME YOU WANT TO GO TO THE MENU, HIT ANY KEY ON THE KEYBOARD. THIS WILL INTERRUPT THE PRINTING AND PRINT THE MENU.

NOTE: AFTER YOU ARE FINISHED USING THE MENU, PRESS "1" TO AGAIN BEGIN THE READOUT. THIS WILL NOT AFFECT THE AVERAGING, UNLESS YOU HAD RESET THE AVERAGING.

R.H. 67% CALIBRATION 0.0 PLENUM 00  
 HIT ANY KEY FOR MENU  

TIME	MODE	GRAIN MOIST	GRAIN TEMP	AMB TEMP	CORN AVE MOIST
09:09A	MON	15.0	77	76	14.8
09:10A	MON	15.2	77	76	14.8
09:10A	MON	14.6	77	76	14.8

## Sample Printer Readout

TIME:  
SET AT COLD START.  
RESET BY MENU INPUT.

MODE:  
MON = MONITOR

03-11-98		SETPOINT 0.0		BIN # 6	
R.H. 67%		CALIBRATION 0.0		PLENUM 00	
HIT ANY KEY FOR MENU					
TIME	MACH MODE	GRAIN MOIST	GRAIN TEMP	AMB TEMP	CORN AVE MOIST
09:09A	MON	15.0	77	76	14.8
09:10A	MON	15.2	77	76	14.8
09:10A	MON	14.6	77	76	14.8

NOT USED

MOISTURE OFFSET:  
DIRECT READING FROM  
THE CONTROL PANEL  
CALIBRATION.

NOT USED

AMBIENT TEMPERATURE:  
FROM WEATHER STATION  
INPUT AT TIME OF  
READING.

AVERAGE MOISTURE:  
GIVES A RUNNING  
AVERAGE OF ALL  
READINGS SINCE START  
OF AVERAGING TIME.  
STARTS WHEN UNIT IS  
STARTED AFTER "COLD  
START" OR WHEN RESET  
FROM MENU.  
NOTE: TO FIND WHEN  
LAST AVERAGE BEGAN,  
PUSH ANY KEY AND READ  
FROM LINE 3 OF MENU.  
TO RESTART PRINTING  
PUSH "1".

GRAIN MOISTURE: ACTUAL  
GRAIN MOISTURE AT THE  
SENSOR - TEMPERATURE  
COMPENSATED

GRAIN TEMPERATURE: ACTUAL  
GRAIN TEMPERATURE AT THE  
SENSOR.

**NOTE:** Replace batteries every year, use two "AA" alkaline batteries.  
Turn off power to the unit, replace the batteries, then turn on power and  
reprogram if "Cold Start" notation is printed.

### PRINTER ASSEMBLY

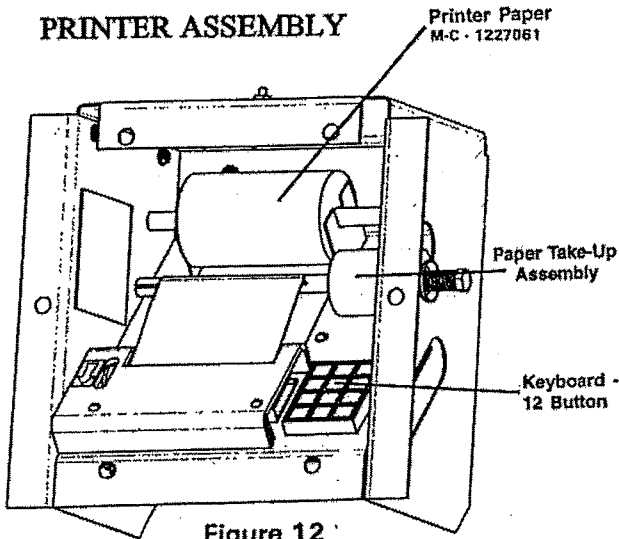

### DIP SWITCH SETTING ON MONITOR BOARD

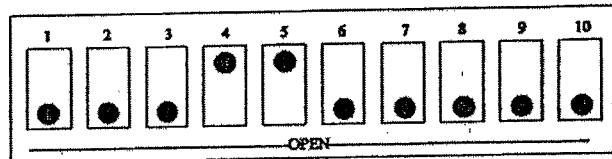

## TROUBLE SHOOTING GUIDE *Print*

PROBLEM	PROBABLE CAUSE	SOLUTION
Blowing control fuses	<ol style="list-style-type: none"> <li>1. Check for loose or shorted leads</li> <li>2. Any component that is bad can cause this - check by isolating one component at a time.</li> </ol>	<ol style="list-style-type: none"> <li>1. Isolate and correct.</li> <li>2. Replace bad component</li> </ol>
Printer spaces several lines but nothing is printed.	<ol style="list-style-type: none"> <li>1. Paper installed with the wrong side up or the wrong type of paper.</li> <li>2. Print head is unplugged or bad.</li> </ol>	<ol style="list-style-type: none"> <li>1. Turn over the paper or install correct paper</li> </ol>
Printer spaces one line, nothing more.	<ol style="list-style-type: none"> <li>1. Computer control card not seated correctly or bad.</li> <li>2. 5 conductor cable loose or installed in error.</li> </ol>	<ol style="list-style-type: none"> <li>1. Insert the computer card or replace card.</li> <li>2. Refer to the decal for correct wiring at the computer jack. Insert the 25 pin jack at the printer.</li> </ol>
Printer does not space, no night light and the paper take-up motor not working.	<ol style="list-style-type: none"> <li>1. No DC power or no AC power or not hooked up.</li> </ol>	<ol style="list-style-type: none"> <li>1. If 5V DC is missing, replace the power supply or repair loose or broken power leads (red and green) or (white and violet).</li> </ol>
Printer doesn't space but has night light.	<ol style="list-style-type: none"> <li>1. Printer motor not plugged in.</li> </ol>	<ol style="list-style-type: none"> <li>1. Plug in the flat, gray cable on the printer and check if broken.</li> </ol>
Prints characters that are unintelligible.	<ol style="list-style-type: none"> <li>1. Computer not working.</li> </ol>	<ol style="list-style-type: none"> <li>1. Power down and retry.</li> </ol>
Top part of the characters are missing.	<ol style="list-style-type: none"> <li>1. Plastic guard too close.</li> </ol>	<ol style="list-style-type: none"> <li>1. Raise the plastic shield.</li> </ol>
Part of each character is missing.	<ol style="list-style-type: none"> <li>1. Head cable loose or print head bad.</li> </ol>	<ol style="list-style-type: none"> <li>1. Reseat the flat brown cable or replace the printer.</li> </ol>
Paper take-up not rolling up the paper.	<ol style="list-style-type: none"> <li>1. Loss of power or bad motor or aluminum shaft binding against the motor.</li> </ol>	<ol style="list-style-type: none"> <li>1. The orange and orange/white wire loose or broken. Retighten or replace the motor assembly or adjust the aluminum shaft by loosening the allen screw.</li> </ol>

# HIGH LIMIT SWITCH & LOW TEMP SHUTDOWN THERMOSTAT CABINET (COOL CHAMBER)

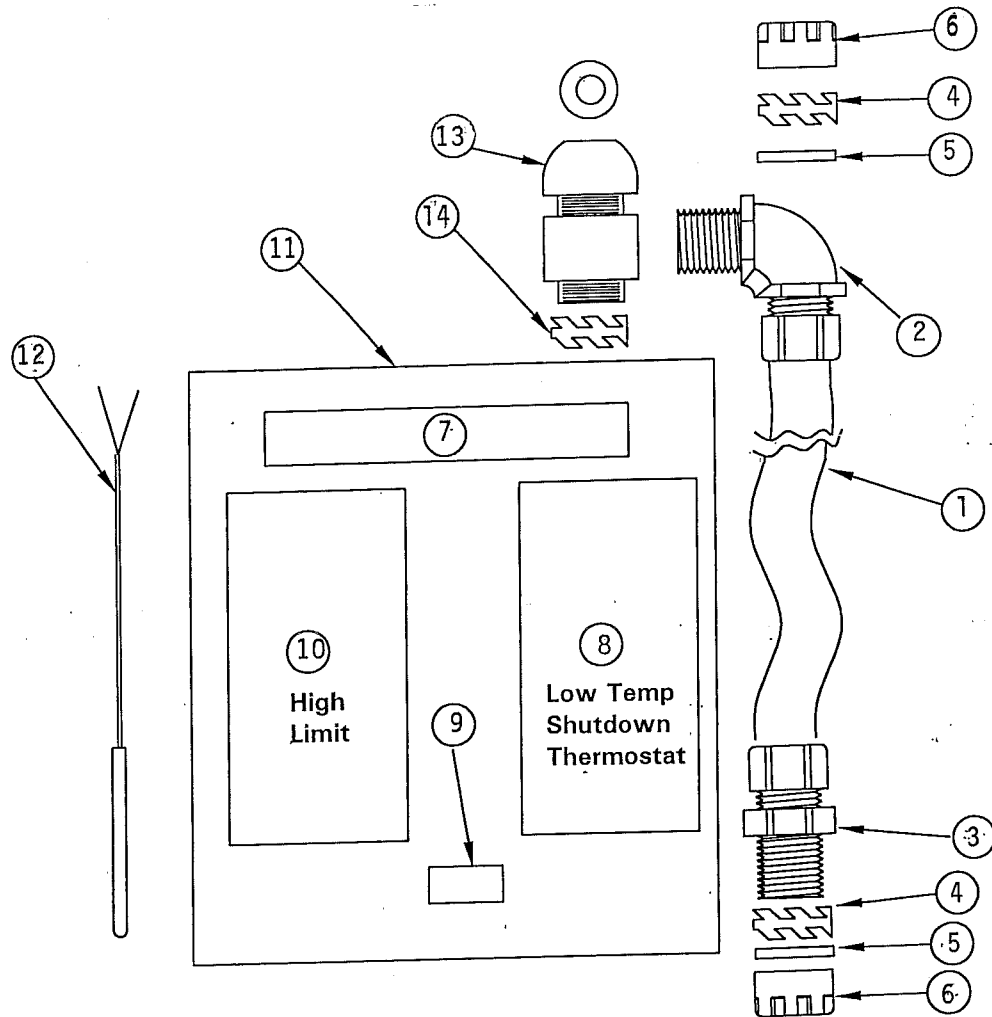

Ref.	Part No.	Qty.	Description
1	121 6900	60 ft.	3/4" (19mm.) LIQUATITE
2	120 6821	1	3/4" 90° LIQUATITE Connector
3	121 6898	1	3/4" LIQUATITE Straight
4	833 296	2	3/4" K/O Locknut
5	124 6853	2	3/4" Sealing Ring Washer
6	121 6910	2	3/4" Insulating Bushing
7	124 6928	1	12 Pin Terminal Block
8	835 916	1	High Limit Control 10' (3m.)
9	125 6805	1	4 Position Screw Terminal
10	444 603	1	Thermostat Low Temp Shutdown
11	121 6967	1	Electrical Junction Box
12	121 6844	1	Thermocouple 60" (152cm.) Honeywell Control
13	121 6813	2	Squeeze Connector
14	121 6915	2	1/2" (12.7mm.) Knockout Locknut
15	120 6890	600 ft.	18# Yellow Wire (Not Shown)
16	124 6968	60 ft.	Insulated Twisted Wire Pair (Not Shown)

## 3HP AC DISCHARGE DRIVE SPEED CONTROL

### Description

The Discharge System is driven by a 3HP variable speed 3 phase 230V AC motor and reduction gearbox.

The speed of the motor is directly proportional to the amount of AC frequency in hertz supplied to it. When frequency in hertz increases, speed increases and when frequency in hertz decreases, speed decreases.

The AC speed control (Figure 54) controls the amount of AC frequency in hertz going to the motor. The Manual Speed Control Dial regulates the amount of AC frequency in hertz the AC speed control supplies to the motor.

When the Moisture Control Switch is in the AUTOMATIC position, the Moisture Control Board controls the amount of DC voltage the AC speed control supplies to the discharge motor.

### Configuration

- 230 volt - single phase input to unit.
- 600 volt - class "cc" 30 amp fuse on AC Drive input
- 230 volt - three phase output to 3HP motor
- 110 volt - control power "on"
- 110 volt - safety circuit relay
- 0-10 volt - input to drive from M-C Board
- 0-10 volt - PWM signal output to DC Meter

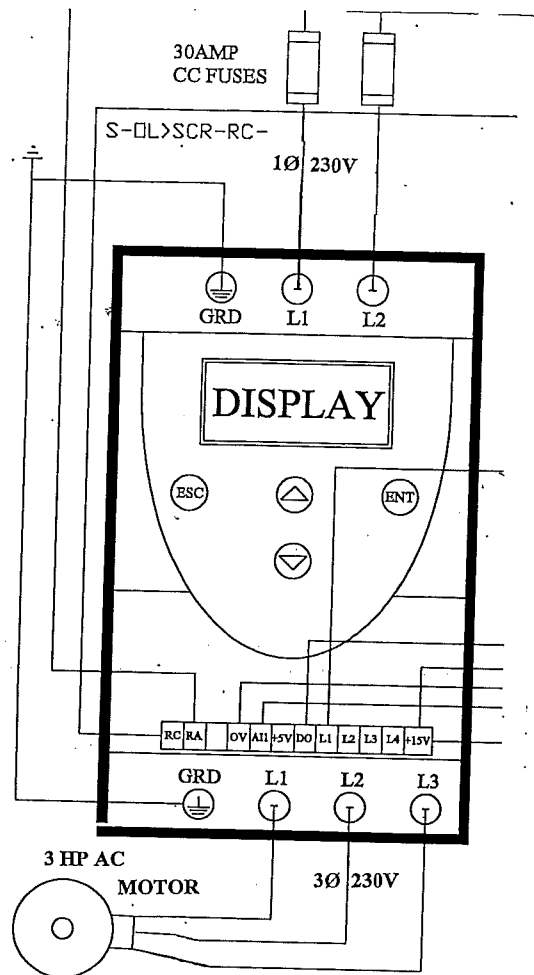

Figure 54

### AC Drive Settings

Rdy = Ready Menu

- bFr = Motor Frequency - 50Hz or 60Hz
- ACC = Acceleration - .1 to 99.9 seconds
- DEC = Deceleration - .1 to 99.9 seconds
- LSP = Low Speed - Hertz
- HSP = High Speed - Hertz
- LtH = Motor Thermal Current - 0 to 1.5 mult
- Alt = Input Signal - 1-10dvc

drc = Motor Control Menu

- StA = Frequency loop - 0 to 100%
- Ufr = IR Compensation - 0 to 200%
- CL1 = Limiting Current - 0.5 to 1.5 mult

FUN = Function Menu

- Use all factory settings

SUP = Monitoring Menu

- Frh = Display Frequency
- LCr = Display Motor Current
- Ulv = Display Line Voltage
- THr = Display Motor Thermal State - 118% shutdown

### M-C Settings

60Hz  
5 seconds  
5 seconds  
10Hz  
60Hz  
10 ac amps  
IOU

20%  
50%  
10 ac amps

M-C Settings

M-C Setting

# 3HP AC DISCHARGE DRIVE SPEED CONTROL (continued)

## Keypad Instructions

Keys are - "ESC", "ENT", ARROW UP & ARROW DOWN.

- ESC - Backs out of menus
- ARROWS - Scroll up and down through menus
- ENT - Displays data numbers and saves data

## Codes That Display Faults On Drive

- OCF = Overcurrent
- SCF = Motor Short - circuit insulation fault
- InF = Internal Fault
- CFF = Configuration Fault
- SOF = Over Speed
- OHF = Drive Overload
- OLF = Motor Overload
- OSF = Over Voltage
- ObF = Over Voltage During Deceleration
- PHF = Line Phase Failure
- USF = Under Voltage
- CrF = Charging Circuit

## CHANGING SETTINGS ON AC DRIVE

All settings for AC Drive Unit can be changed with power on to dryer, but power off to discharge system. The 230-volt single phase must be powered on, so that the digital display on the unit is powered up.

### 1.0 How to increase or decrease minimum discharge rate.

- 1.1 Press the "ESC" key until "rdy" appears on display.
- 1.2 Arrow down until unit displays "LSP".
- 1.3 Press "ENT" to display data.
- 1.4 The data displayed is in units of hertz, our range is 0 to 60Hz.
- 1.5 Arrow up or down to change the number. The higher the number the faster we discharge. Factory setting should be 5.0 Hz.
- 1.6 Press "ENT" twice to save valve, once it is at desired setting.
- 1.7 Press "ESC" to get back to the "rdy" display.

### 2.0 How to increase or decrease maximum discharge rate.

- 2.1 Press the "ESC" key until "rdy" appears on display.
- 2.2 Arrow down until unit displays "HSP".
- 2.3 Press "ENT" to display data.
- 2.4 The data displayed is in units of hertz, our range is 0 to 60 HZ.
- 2.5 Arrow up or down to change the number. The higher the number the faster we discharge. Factory setting should be 60.0 Hz.
- 2.6 Press "ENT" twice to save valve, once it is at desired setting.
- 2.7 Press "ESC" to get back to the "rdy" display.

### 3.0 How to increase or decrease current limit of discharge rate.

- 3.1 Press the "ESC" key until "rdy" appears on display.
- 3.2 Arrow down until unit displays "drC".
- 3.3 Press "ENT" to display data (Motor Control Data).
- 3.4 Arrow down the menu until "nCr" appears.
- 3.5 The data displayed is in units of AC amps.
- 3.6 Arrow up or down to change the number. This will increase the amount of amps the motor can draw to drive the discharge system. The higher the number, the more torque the motor has. Factory setting is (10 amps); this could be increased to 12 amps if discharge will not start-up.
- 3.7 Press "ENT" twice to save valve, once it is at desired setting.
- 3.8 Press "ESC" to get back to the "rdy" display.

## 3HP AC DISCHARGE DRIVE SPEED CONTROL (continued)

### 4.0 How to increase IR Compensation for discharge.

- 4.1 Press the "ESC" key until "rdy" appears on display.
- 4.2 Arrow down until unit displays "drC".
- 4.3 Press "ENT" to display data (Motor Control Menu).
- 4.4 Arrow down until unit displays "Ufr".
- 4.5 The data displayed is in units of percentage.
- 4.6 Arrow up or down to change the number. The range is from 0 to 200%. This is used to optimize torque while adjusting speed. This should only be re-adjusted if discharge rate can not be held steady in manual mode. Factory set should be 50%.
- 4.7 Press "ENT" twice to save valve, once it is at desired setting.
- 4.8 Press "ESC" to get back to the "rdy" display.

### 5.0 How to increase or decrease Acceleration for discharge.

- 5.1 Press the "ESC" key until "rdy" appears on display.
- 5.2 Arrow down until unit displays "ACC".
- 5.3 Press "ENT" to display data.
- 5.4 The data displayed is in units of seconds.
- 5.5 Arrow up or down to change the number. The higher the number the faster we change speed of discharge. Factory setting should be 5 seconds.
- 5.6 Press "ENT" twice to save valve, once it is at desired setting.
- 5.7 Press "ESC" to get back to the "rdy" display.

### 6.0 How to increase or decrease Deceleration for discharge.

- 6.1 Press the "ESC" key until "rdy" appears on display.
- 6.2 Arrow down until unit displays "dEC".
- 6.3 Press "ENT" to display data.
- 6.4 The data displayed is in units of seconds.
- 6.5 Arrow up or down to change the number. The higher the number the faster we change speed of discharge. Factory setting should be 5 seconds.
- 6.6 Press "ENT" twice to save valve, once it is at desired setting.
- 6.7 Press "ESC" to get back to the "rdy" display.

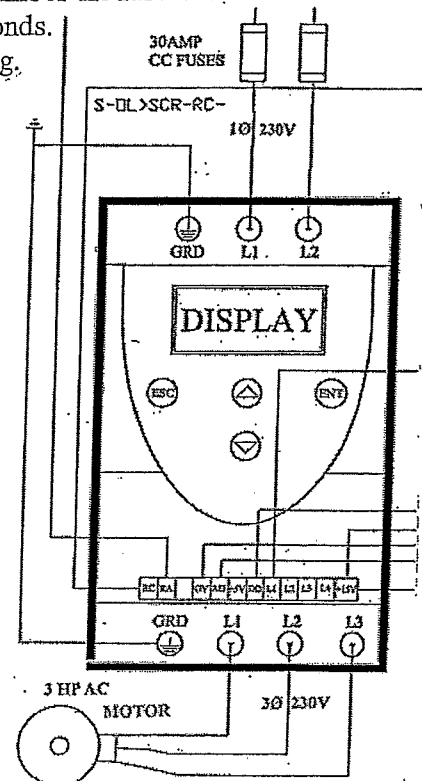



# FAN MOTOR SOFT STARTER

## Configuration

- Input Volt - 208, 230, 460 & 575 Voltage
- 600 volt – (2) class “cc” 0.5 amp fuses on controller input
- 110 volt – Non-7amp fuse for 110 volt input
- By-pass Contactor for normal running
- 110 volt – control power “on” through relay
- 110 volt – safety circuit relay to circuit breaker shunt trip

## Settings

Rdy = Ready Menu

SET = Setting Menu

- In = Nominal Motor Current 124 amps
- ILt = Current Limit in Percentage 450%
- ACC = Acceleration Ramp Time 15 seconds
- T90 = Initial Starting Torque 50%
- Sty = Type of Fan Stop F

SUP = Monitoring Menu

- tHr = Motor Thermal State in Percentage
- LCr = Display Motor Current in Amps MC Setting
- Rnt = Operating Time (Last Reset)
- Ltr = Motor Torque in Percentage

## KEYPAD INSTRUCTIONS

KEYS ARE – “ESC”, “ENT”, ARROW UP & ARROW DOWN

- ESC – BACKS Out of Menu’s
- ARROWS – Scroll up and down through menu’s
- ENT – Displays Data Numbers and Saves Data

## CODES THAT DISPLAY FAULTS ON DRIVE

### NON-RESETTABLE FAULTS

- InF = Internal Fault
- OCF = Over Current
- PIF = Phase Inversion
- EEF = Internal Memory Fault

### AUTO-RESET FAULT

- PHF = Loss of a Line Phase
- FrF = Line Frequency is out of Tolerance
- USF = Power Supply Fault
- CLF = Control Line Failure

### RESETTABLE FAULTS

- CFF = Invalid Configuration

### MANUAL RESET FAULT

- OLC = Current Overload
- OLF = Motor Thermal Overload
- ULF = Motor Underload

# START-UP PROCEDURE

## General

**IMPORTANT:** Inspect for and remove any foreign materials (nuts, bolts, tools, parts, etc.) from grain columns, discharge sweep and heat/cool chambers before filling dryer with grain.

**CAUTION:** Lock out and tag out high voltage disconnect when working inside any control cabinet or inside dryer.

1. Adjust the High Limit and Low Temp Shutdown Thermostats that are placed in a 12 x 12" (30.5cm.) cabinet located in the cooling section of the dryer.

Set the High Limit at 30° to 50° above drying temperature. Set the Low Temp Shutdown Thermostat at 120° (49°C).

These recommended settings are to avoid nuisance shutdowns.

2. Make sure that gas supply is turned off and locked out. Remove end cap from bottom of 3/4" (19mm.) drip leg (page ) and open 3/4" (19mm.) hand valve at bottom of drip leg to allow any water to drain from gas line. Once water has drained, shut 3/4" (19mm.) hand valve and recap end of drip leg.

3. Remove Burner Cover from top of Burner.

4. Turn on Main Gas Supply Valve to dryer and 2" (5cm.) Hand Valve just before dryer Gas Pressure Regulator.

5. Turn all rotary switches on Remote Cabinet Panel to the OFF position.

6. Make preliminary settings to the Adjustable (0 to 180) second Fill Timer and to the (0 to .60) minute Grain Flow Timer that are located in the Remote Cabinet. Set the Fill Timer to (60) seconds and the Grain Flow Timer to (10) minutes. Make sure that arrows on Grain Flow Timer are set at 10X and M (minutes). This can easily be

0 to 180 Second  
Fill Timer

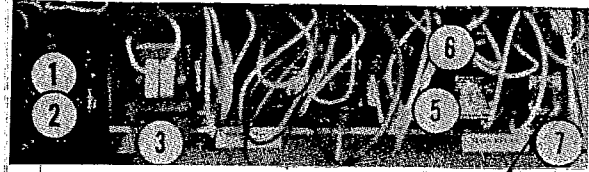
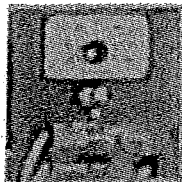

0 to 60 Minute  
Grain Flow Timer

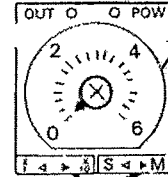

NOTE:  
SET TIMER FOR X 10 AND  
MINUTES. ADJUST FROM  
UNDERSIDE OF TIMER.

done by removing Timer from Socket and using a small flathead screwdriver. Once set, return Timer to socket.

7. Turn Low Temp Shutdown Switch to START position.



8. Place Disconnect Switch on High Voltage Cabinet into the ON position.

9. Turn Power On Rotary Switch on Remote Cabinet Panel to ON position. Power On Light will light.

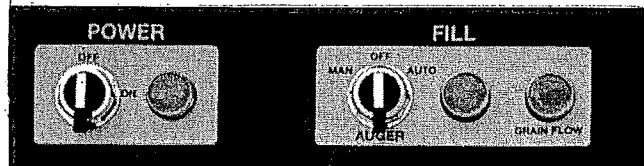

10. Press Fan Start Button to start Fan. Once Fan is operating at full speed, dryer is ready to be filled with grain.

11. Turn Fill Switch to the MANUAL position bypassing the (0 to 60) minute Grain Flow Timer. The Fill Light will be ON. Now the fill system begins to fill the dryer with wet grain until the grain reaches the Rotary Fill Switch in the Hopper. When the Rotary Switch opens from the pressure of the wet grain, the fill system stops and the Fill Light goes OUT. Now turn Fill Switch to the AUTO position

**IMPORTANT:** If the Grain Flow Timer has not been set, the dryer will shut down when the Fill Switch is turned from MANUAL to AUTOMATIC.

Once is AUTO, the fill system will start after the (60) second Fill Timer delay and the Fill Light will be ON.

Check the refill time a minimum of (5) times. The Fill Light will light when the fill system begins to operate. The length of time that the Fill Light is ON plus the (60) second delay setting on the Fill Timer is the refill time.

Average (5) refill times and reset the Grain Flow Timer to operate (5) minutes longer. For example, if it takes the fill system an average of (6) minutes to refill the dryer, set the Grain Flow Timer to run (11) minutes.

**NOTE:** The Grain Flow Timer does not operate when the wet Grain Flow Timer is in the MANUAL or OFF position.

#### Grain Flow Timer Operation

The Grain Flow Timer will start when the fill system starts. The red light on the face of the timer will be on and timer will start to count down to zero. After the fill system refills the dryer and shuts off, the Fill Light will go out and the timer will automatically reset. The red light on the face of the timer will be out.

If there is an insufficient grain supply, the fill system will continue to run beyond the (6) minute refilling period. When the fill system has run the length of time that the Grain Flow Timer has been set, the dryer will shut down.

The Grain Flow, High Limit, Power On, and the (2) red lights at the top of the Grain Flow Timer will be ON.

12. Adjust Air Pressure Switch (located inside Motor Control Cabinet) so that Air Pressure Light goes on when dryer is full of grain and the fan is operating.

**NOTE:** If fan stops for any reason or grain columns start to empty, Air Pressure Light should go out.

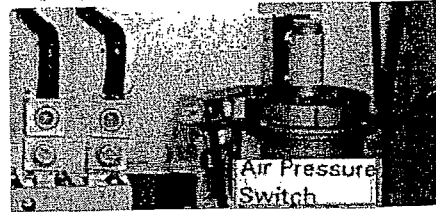

Adjust Air Pressure Switch when fan is operating by removing red plastic cover and turning the adjusting screw clockwise until Air Pressure Light goes out. Then slowly turn screw counterclockwise until Air Pressure Light comes on. Then add one-half screw turn counterclockwise.

13. Move Maxon Valve hand lever to the OPEN position. Valve has a sight glass to indicate if valve is OPEN or CLOSED and is located on gas train along side of dryer base.
14. Open 3" (7.6cm.) Hand Valve on gas train downstream from the Maxon Valve. Gas Pressure Gauge located after Gas Pressure Regulator should read 5/8 psig. (4.3Kpa).
15. Turn Ignition Switch to ON position energizing Ignition Board and a (10) second air purge cycle begins. After purge cycle, a (10) second trial for Burner Ignition starts. The Gas Valve Light should be ON during the (10) second trial for burner ignition.
16. The Honeywell Gas Controller screen should display "M" for Manual and a 30% opening of valve. If burner does not light on second trial for ignition, adjust Manual percentage plus or minus up to 10% to change valve opening. This trial and error process is required to obtain the proper air to gas mixture for burner operation.

## Operator Interface and Key Functions

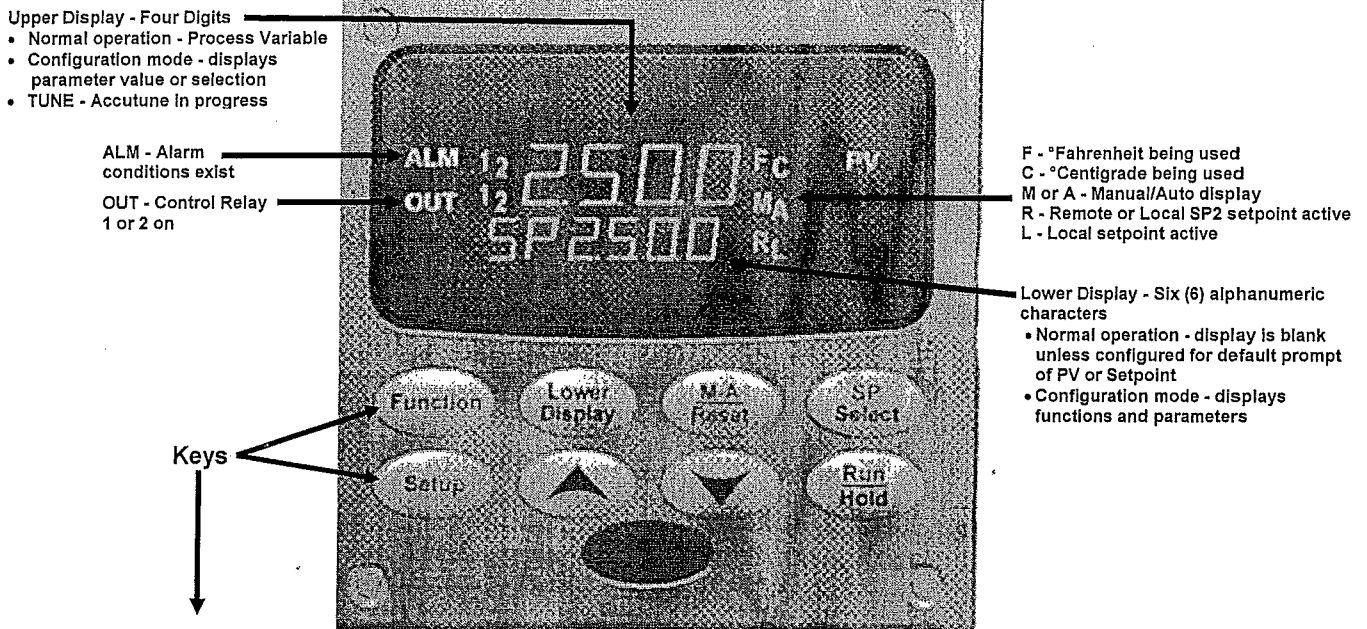

Used with Set Up Key to select individual functions of selected Set Up group.



Returns Controller to normal display from Set Up mode. Toggles various operating parameters for display.



Selects Manual or Auto mode. Resets the latching Limit Controller relay.



Places controller in the Configuration Set Up group select mode. Scrolls through the configuration Set Up groups.



Hold key to cycle through configured setpoints.



Increase setpoint or output values. Increases the configuration values or changes functions in Configuration mode groups.



Decreases setpoint or output value. Decreases the configuration values or changes functions in Configuration mode groups.



Enables Run/Hold of the SP Ramp or Program. Acknowledges a latched alarm or diagnostic message.

### Key Error Message

When a key is pressed and the prompt KEYERR appears in the lower display, it will be for one of the following reasons:

- parameter is not available,
- not in Set Up mode, press SET UP key first,
- key malfunction.

17. Once burner ignition takes place and the gas valve light has been ON for longer than (10) seconds, press the Auto/Man key on the Honeywell Controller. The "M" on the display screen will change to "A" for Automatic control.

Then use the Arrow Keys on Controller to scroll up to the desired plenum (drying) temperature. Once in Automatic, the controller displays (2) numbers. The upper number is the actual plenum (drying) temperature in Fahrenheit, and the lower is the Set Point (SP) or the desired plenum (drying) temperature. The bottom number (SP) is the only number that can be adjusted with the Arrow Keys.

18. The plenum temperature may take up to (30) minutes to stabilize. The Controller is programmed to slow down the rate that the temperature is increasing as the plenum chamber gets closer to the Set Point. This avoids tripping the High Limit Switch and exceeding the desired plenum (drying) temperature.

19. Once the plenum chamber reaches the desired temperature, turn Low Temperature Shutdown Switch to the RUN position. If burner flame goes out for any reason, plenum chamber loses temperature and dryer will shut down.

20. If plenum chamber does not stay within (5) degrees plus or minus of Set Point, Hon-

eywell Controller needs to be Accutuned (see Honeywell Controller step by step procedures).

21. Turn Discharge Auger Switch to the ON position and the Metering Switch to the MANUAL position, the Sweep System and Auger will start to rotate discharging grain from dryer. Discharge speed rate (0-10) volts is displayed on Discharge Speed Meter. Adjustment of discharge rate in MANUAL is made with the SCR Speed Control Dial which is graduated from (0) slowest to (10) fastest. Run discharge system in MANUAL until the desired grain discharge moisture or temperature is obtained.

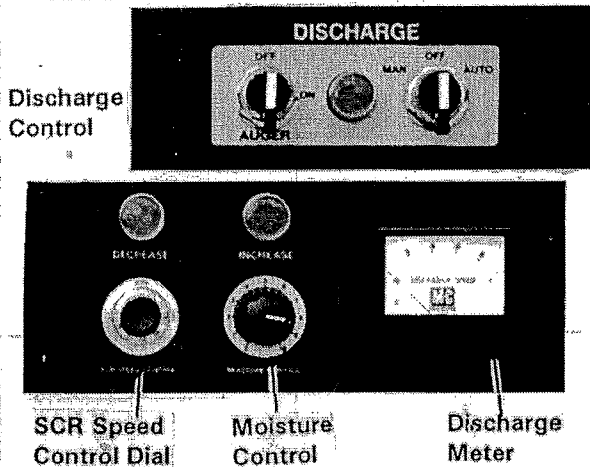

Test discharged grain moisture every (15) minutes until moisture stabilizes. If moisture is too high after it stabilizes, turn Speed Control Dial down to decrease unloading speed. If moisture is too low after it stabilizes, turn Speed Control Dial up to increase unloading speed.

**NOTE:** After any change to unloading speed, wait (45) to (60) minutes before making any further adjustment. This action allows the grain to pass completely through the dryer.

22. Once-discharged grain moisture content is satisfactory, it is time to balance the Discharge Lights (+ and -). First turn Moisture Control Dial until both Discharge Lights go out simultaneously. This is the dryer discharge Set Point (desired moisture content of discharged grain). It is now time to turn the MAN/AUTO Metering Switch from MANUAL to the AUTOMATIC position. The Discharge Speed Meter should not change speed when changing from MANUAL to AUTOMATIC.
23. Once dryer discharge system is operating in AUTOMATIC, the discharge speed will change to maintain the desired moisture content of the discharged grain. When the Minus (-) Light is ON, the discharge system is decreasing speed to maintain the required moisture content of the discharged grain. When the Plus (+) Light is ON, the discharge system is increasing speed to maintain the required moisture content of the discharged grain. Once the Discharge Meter Switch is in AUTOMATIC, the Manual Speed Control Dial is no longer functional.

24. To change moisture content of the discharged grain when in AUTOMATIC, use the Moisture Control Dial which is graduated from (0 to 10), the (0) end of the dial the wetter value and (10) at the other end of the dial the drier value.

If it is necessary to change the discharge moisture content of the grain, simply turn the Moisture Control Dial up to a higher number for drier grain and the Minus (-) Light will light. If the Moisture Control Dial is turned down to a lower number, wetter grain will be discharged and the Plus (+) Light will light.

# MAXON BURNER LOWER GAS TRAIN COMPONENTS

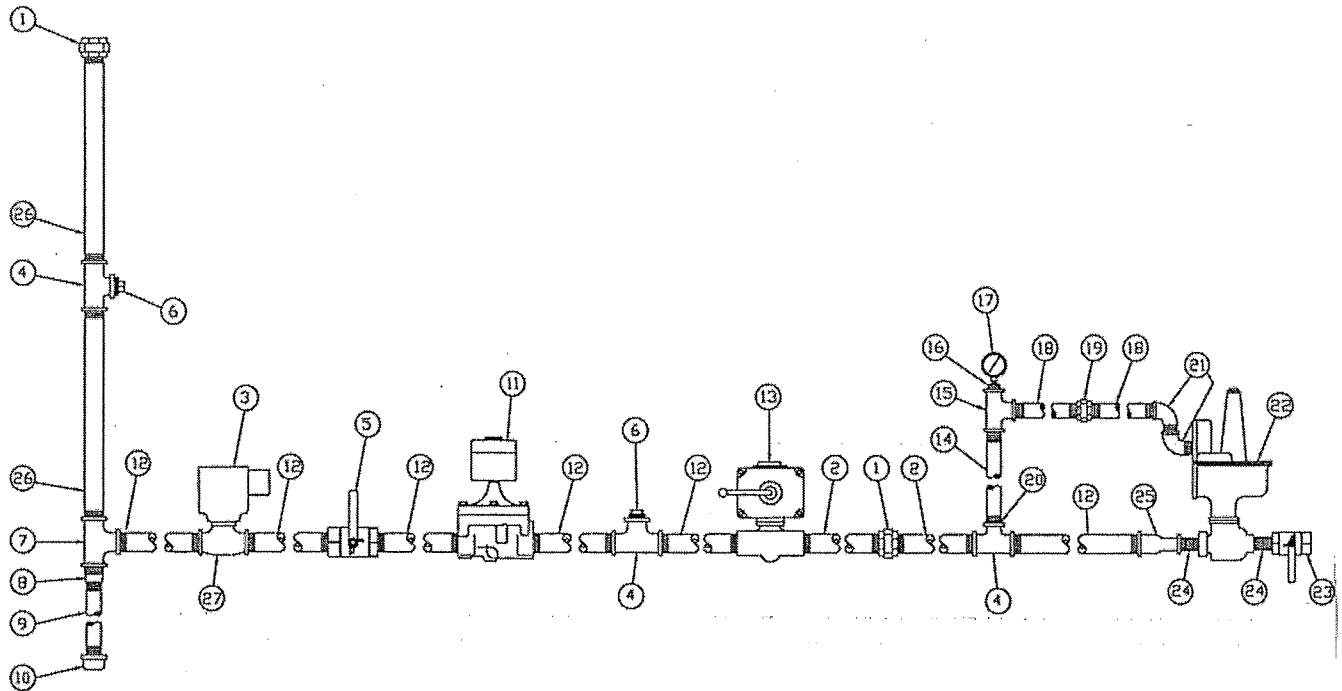

Ref.	Part No.	Qty.	Description
1	125 8083	2	3" (7.6cm) Std. Union
2	480 181	7	3 x 3" (7.6x7.6cm) Std. Nipple
3	125 6980	1	Actuator (ASCO)
4	480 183	3	3 x 3 x 1" (7.6x7.6x2.54cm) Std. Tee
5	480 073	1	3" (7.6cm) Shut-Off Valve
6	128 8047	1	1" (2.54cm) Pipe Plug
7	480 185	1	3 x 3 x 3" (7.6x7.6x7.6cm) Std. Tee
8	480 186	1	3 x 1" (7.6x2.54cm) Reducer Bushing
9	128 8043	1	1 x 6" (2.54x15cm) Ex. Hvy. Nipple
10	129 8032	1	1" (2.54cm) Pipe Cap
11	480 074	1	3" (7.6cm) Solenoid Valve
12	480 180	6	3 x 5" (7.6x12.7cm) Std. Nipple
13	480 072	1	3" (7.6cm) Maxon Shutdown Valve
14	121 8092	1	¾ x 4½" (1.9x11.4cm) Ex. Hvy. Nipple
15	121 8070	1	¾ x ¾ x ¾" (1.9x1.9x1.9cm) Std. Tee
16	121 8030	1	¾ to ¼" (19 to 6.35mm) Reducer Bushing
17	120 7007	1	Pressure Gauge 0-3 psig, (0-20 kpa)
18	121 8005	2	¾" (1.9cm) Ex. Hvy. Close Nipple
19	121 8028	1	¾" (1.9cm) Std. Union
20	123 8027	1	¾ to 1" (1.9 to 2.54cm) Reducer Bushing
21	096 055	2	¾" (1.9cm) 90° Std. Elbow
22	480 071	1	Pressure Regulator
23	128 8079	1	2" (5cm) Shut-Off Valve
24	128 7523	2	2" (5cm) Close Nipple
25	128 8078	1	3" to 2" (7.6 to 5cm) Reducer Coupling
26	480 182	2	3 x 10" (7.6x25.4cm) Pipe Nipple
27	125 6985	1	3" (7.6cm) Proportional Valve

# MAXON-BURNER UPPER GAS TRAIN COMPONENTS

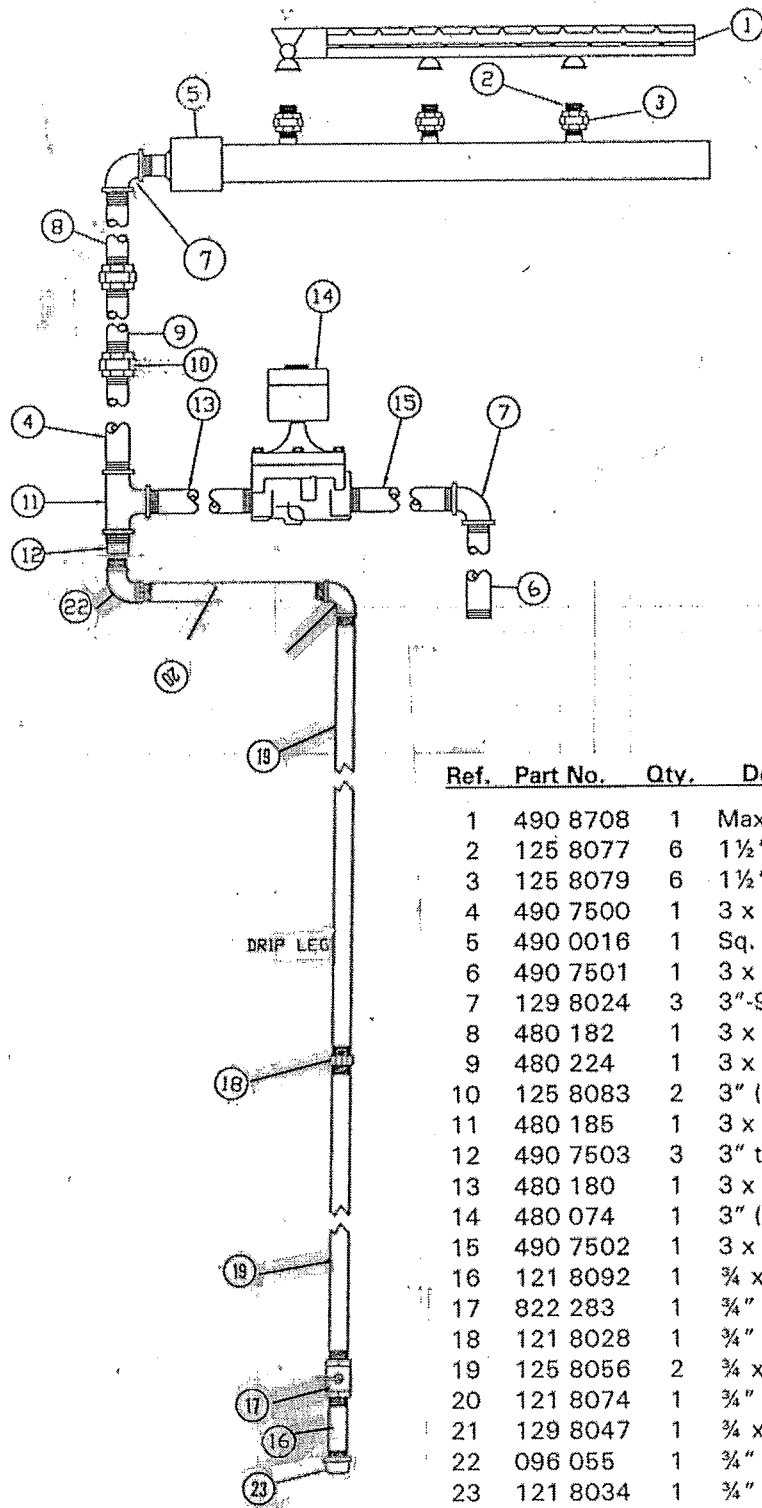

Ref.	Part No.	Qty.	Description
1	490 8708	1	Maxon Burner
2	125 8077	6	1½" (3.8cm) Std. Close Nipple
3	125 8079	6	1½" (3.8cm) Std. Union
4	490 7500	1	3 x 6" (7.6x15.2cm) Std. Nipple
5	490 0016	1	Sq. Tube Manifold
6	490 7501	1	3 x 108" (7.6x274cm) Std. Pipe
7	129 8024	3	3"-90° (7.6cm) Elbow
8	480 182	1	3 x 10" (7.6x25.4cm) Std. Nipple
9	480 224	1	3 x 155" (7.6x394cm) Std. Pipe
10	125 8083	2	3" (7.6cm) Std. Union
11	480 185	1	3 x 3 x 3" (7.6x7.6x7.6cm) Std. Tee
12	490 7503	3	3" to ¾" (7.6 to 1.9cm) Reducer Bushing
13	480 180	1	3 x 5" (7.6x12.7cm) Std. Nipple
14	480 074	1	3" (7.6cm) Solenoid Valve
15	490 7502	1	3 x 15" (7.6x38cm) Std. Nipple
16	121 8092	1	¾ x 4" (1.9x10cm) Std. Nipple
17	822 283	1	¾" (1.9cm) Hand Valve
18	121 8028	1	¾" (1.9cm) Std. Union
19	125 8056	2	¾ x 72" (1.9x183cm) Std. Pipe
20	121 8074	1	¾" (1.9cm) Std. 90° Elbow
21	129 8047	1	¾ x 28½" (1.9 x 72.4cm) Std. Pipe
22	096 055	1	¾" (1.9cm) Std. Street Elbow
23	121 8034	1	¾" (1.9cm) Pipe Cap

# MAXON BURNER

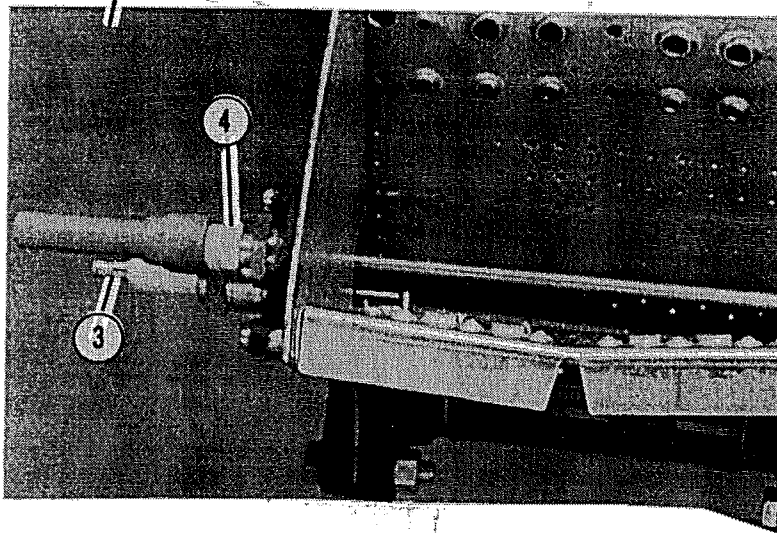
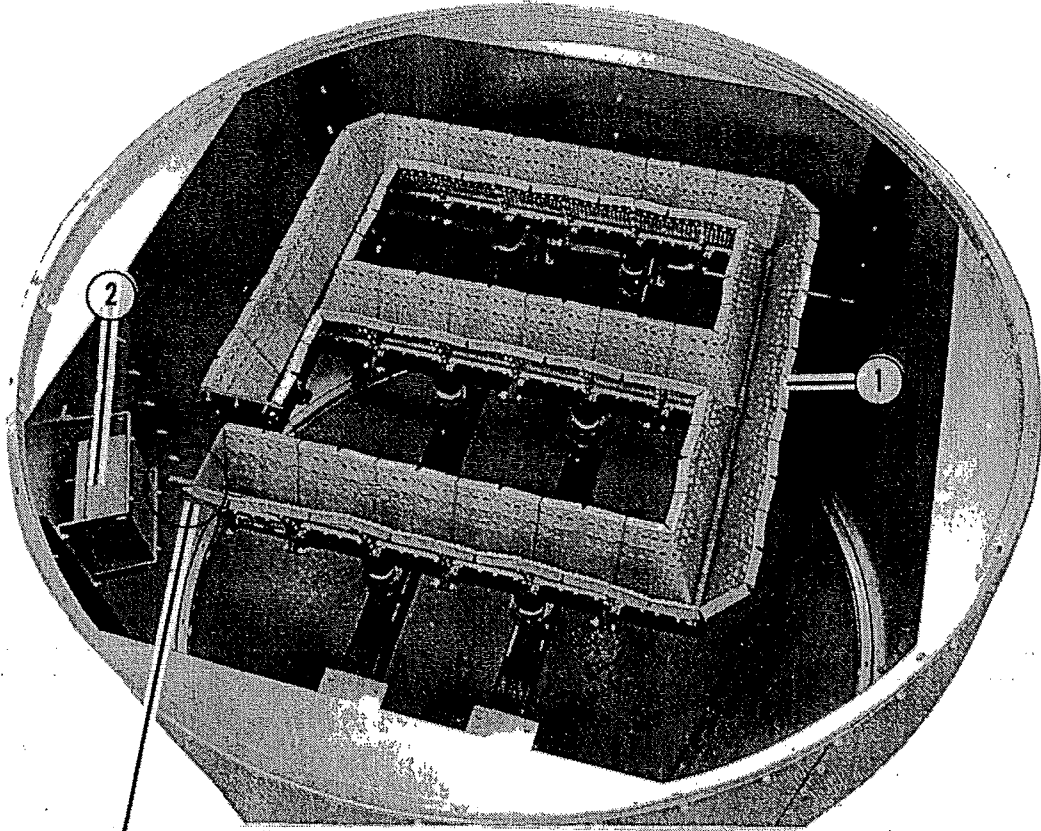

Ref.	Part No.	Qty.	Description
1	490 8708	1	Burner
2	128 6944	1	Ignition Board Cabinet
	128 2938	1	Ignition Board Mount Plate
	125 6964	1	Ignition Board w/o Prepurge

Ref.	Part No.	Qty.	Description
3	124 7000	1	Spark Plug
4	124 6872	1	Flame Sensing Probe
<b>Not Shown:</b>			
	490 2842	1	Burner Cover



# FAN AND MOTOR DRIVE

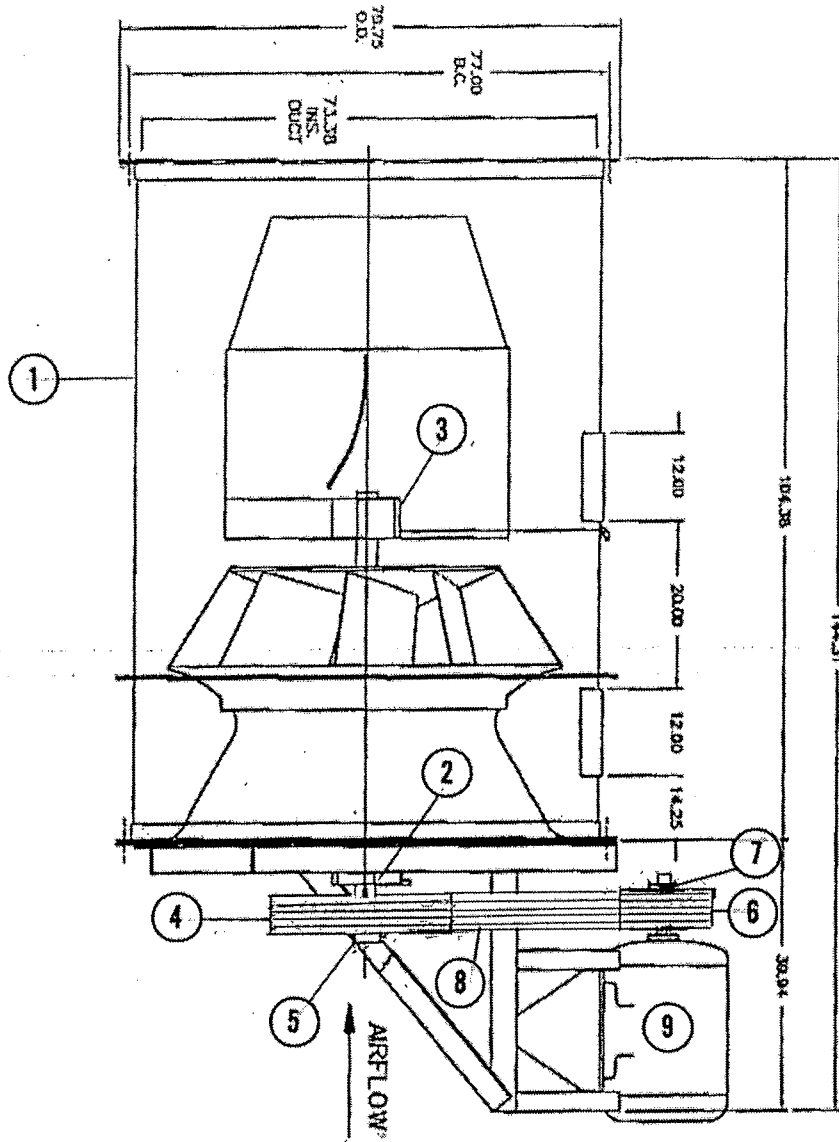

Ref.	Part No.	Qty.	Description
1	490 8705	1	Fan (In Line Centrifugal)
2	490 6003	1	Air Intake End P.B. Bearing 3-7/16" (87.3mm)
3	490 6004	1	Exhaust End P.B. Bearing 3-7/16" (87.3mm)
4	490 6202	1	Pulley "(E)" 4/5V/21.2" (53.84cm) - Fan
5	490 6006	1	Bushing "(E)" 2-5/16" (7.46cm) - Fan
6	490 6203	1	Pulley "(E)" 4/5V/11.3" (28.7cm) - Motor
7	490 6002	1	Bushing 2 7/8" (13cm) "E" - Motor
8	490 6101	4	5VX1400 Belt
9	490 6800	1	100HP Motor 3Ø/230/460V
	490 6848	1	100HP Motor 3Ø/575V

## OPTIONAL REMOTE CABINET - MODEL 2000 BUTTONS, DIALS, LIGHTS, METERS, & SWITCHES

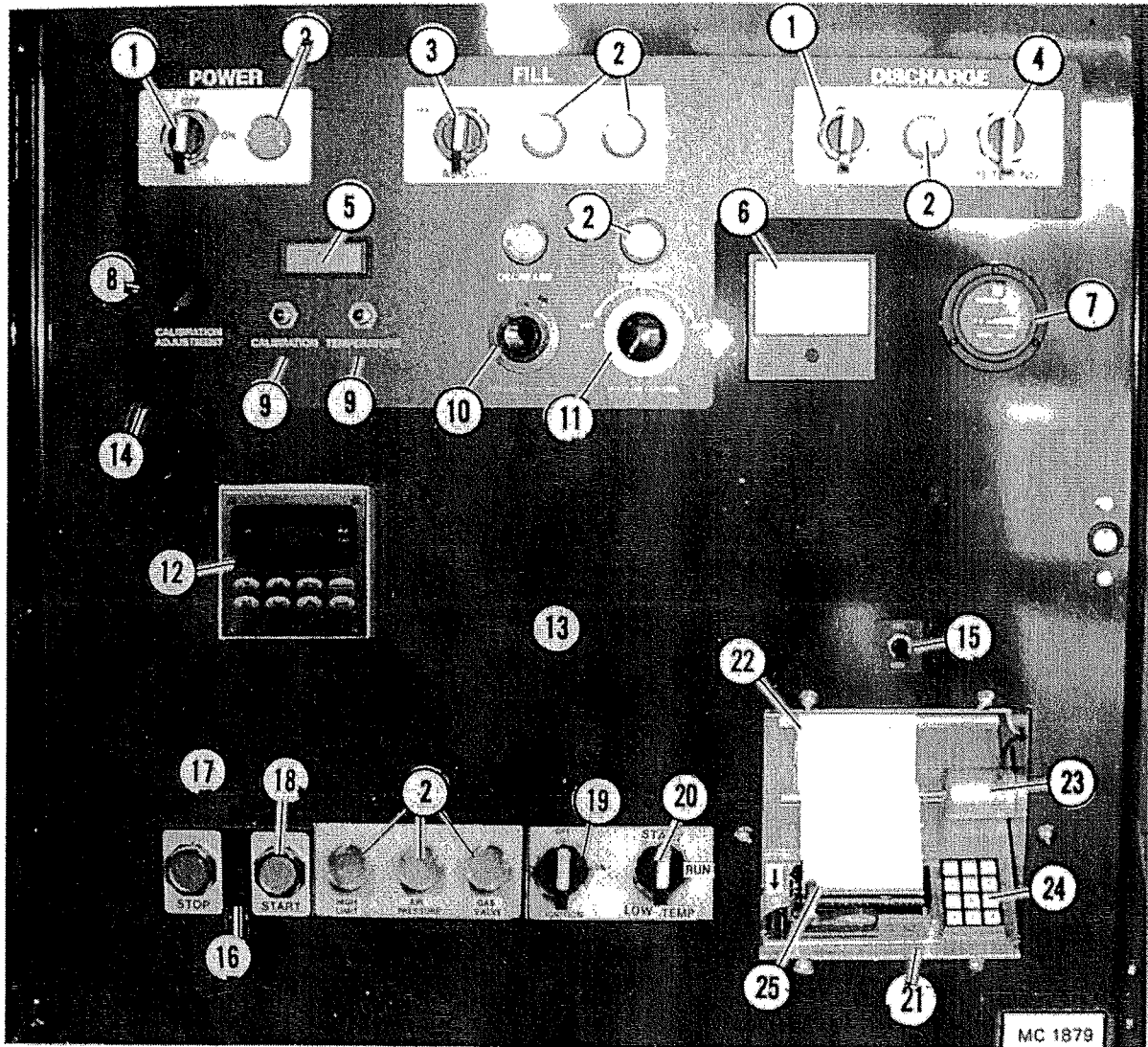

Ref. Part No.	Qty.	Description
1	125 6809	2 OFF-ON-ON Momentary Contact Switch
2	125 6808	AR Indicator Light
3	125 6810	1 Switch ON-OFF-ON (Level Auger)
4	125 6811	1 Switch ON-OFF-ON (Metering Rolls)
5	122 7068	1 Digital Display Meter
6	125 6862	1 Discharge Meter
	127 6865	1 Resistor 3.9K-1/2 Watt
7	444 645	1 Hour Meter
8	122 7069	1 Calibration Potentiometer - Monitor
9	125 6834	2 Push Button-Calibration and Grain Temperature
10	124 1195	1 SCR Drive Potentiometer (10 Turn with Wires) 42" (107cm)
	124 6892	1 Multi Dial with Lock
11	124 6955	1 Moisture Control Potentiometer & Wires 60" (153cm.)
	124 6941	1 Dial

Ref. Part No.	Qty.	Description
12	490 6814	1 Temperature Controller - UDC2500
	124 6961	1 Temperature Controller Thermocouple 180" (4.6m)
13	490 465	1 Inside Control Door (only)
14	124 8303	1 Power Control Bezel
15	125 6839	1 Switch ON-OFF - Printer
16	124 8304	1 Fan & Burner Control Bezel
17	128 6845	1 Stop Button - Fan
18	128 6844	1 Start Button - Fan
19	125 6812	1 Switch OFF-ON - Ignition
20	125 6817	1 Switch START/RUN - Low Temp.
21	122 7074	1 Printer Assembly
22	122 7061	1 Thermal Paper 3 1/8" x 246 ft. (7.94cm x 75m)
23		1 Printer Take-Up Assembly
24		1 Keyboard, 12 Button
25		1 Printer with Flat Cable

# 115V ELECTRICAL COMPONENTS REMOTE CABINET - MODEL 2000

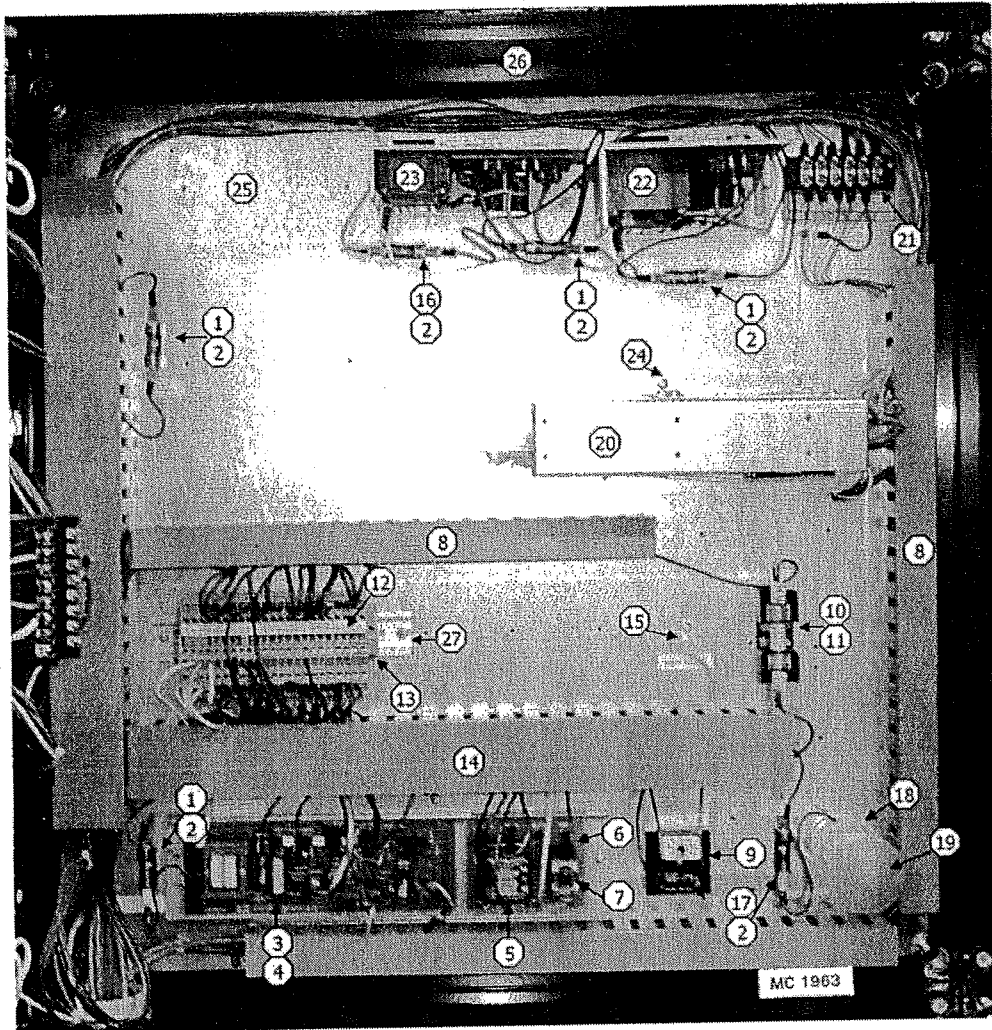

Ref.	Part No.	Qty.	Description	Ref.	Part No.	Qty.	Description
1	124 6937	4	Fuse 1 Amp - 115V Slow Blow	18	124 6841	1	Light Bulb Socket
2	125 6836	6	Fuse Holder	19	124 6850	1	25 Watt Rough Service Bulb
3	124 6995	1	Moisture Control Board	20		1	Monitor & Printer Interface Board Holder
4	128 5828	1	Snap Track 14" (36cm)		122 7066	1	Monitor Interface Board °Fahrenheit
5	021 6809	1	Relay		122 7067	1	Monitor Interface Board °Celsius
6	124 6972	1	Relay and Timer Socket Board		122 7071	1	Printer Interface Board °Fahrenheit
7	124 6978	1	60 Minute Adjustable Timer		122 7072	1	Printer Interface Board °Celsius
8	128 8705	AR	Wire Raceway Track 1" (2.54cm)	21	125 6830	1	Terminal Blocks-Sensor-6 Position
9	124 6996	1	0 to 3 Minute Adjustable Timer	22	122 7070	1	Printer Power Supply
10	125 6956	1	7 Amp Fuse (NON-7)	23	122 7065	1	Moisture Monitor Power Supply
11	128 6851	1	Fuse Holder	24	124 6214	1	Mount Bracket for Interface Board Holder #
12	125 7010	23	Terminal Block - Spring 3 Wire	25	124 4877	1	Component Mounting Board
	125 7012	23	Terminal Marker Strip	26	125 6952	1	Cabinet 30 x 30" (76 x 76cm)
	125 7006	1	Terminal End Plate	27	490 6831	AR	Din Rail
13	490 6833	2	Terminal End Retainers				
14	128 8708	AR	Wire Raceway Track 2" (5cm.)				
15	125 6975	1	Ground Lug (1) Pole				
16	125 6838	1	Fuse 3/4 Amp. - 115V				
17	125 6861	1	Fuse 2 Amp. - 115V				
				Not Shown:			
				128 7016	1	Sensor with 40 ft. (12.2m) Cable	

# MOTOR CONTROL CABINET 2000 - DIRECT START 3Ø 60HZ - 460V W/REMOTE CABINET CONTROLS

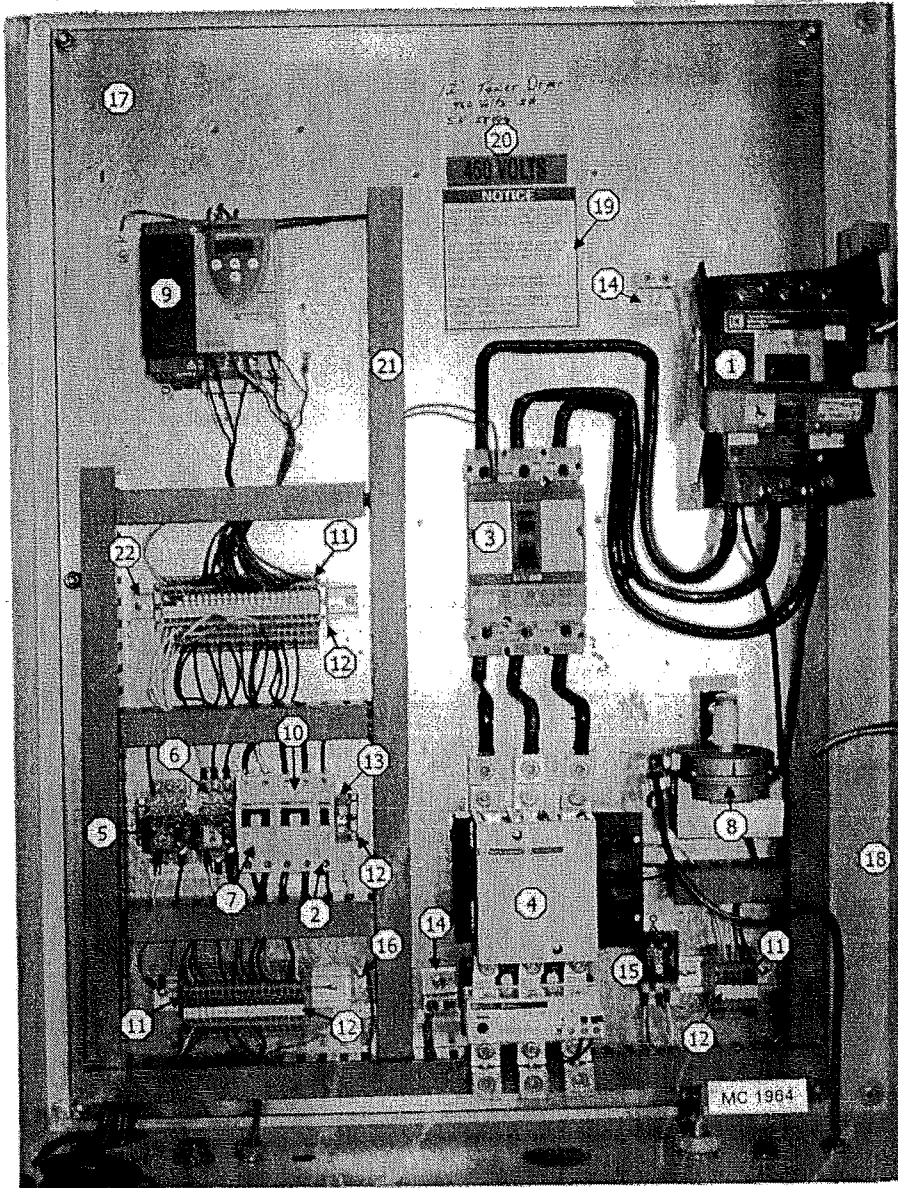

Ref.	Part No.	Qty.	Description	Ref.	Part No.	Qty.	Description
1	490 6903	1	Disconnect Switch 225 Amps	10	125 6992	1	Circuit Breaker 8 Amp (2) Pole 460V
2	125 6988	1	Circuit Breaker 8 Amp (1) Pole 115V	11	125 7000	47	Terminal Block Spring Wire
3	123 6967	1	Protector GV7RE150		125 7012	47	Terminal Marker Strip
	125 6870	1	Fault GV7AE11		125 7006	1	Terminal End Plate
4	125 6858	1	Contactor LCIF150G6	12	490 6833	7	Terminal End Retainer
	490 6808	2	Lug Kit	13	125 7020	1	Neutral Terminal Block
	122 6868	1	Replace Coil LXIFF095	14	125 6918	2	Ground Lug (2) Pole
5	021 6809	1	Relay (Linear Limits)	15	124 6954	1	Fill Relay
	021 6810	1	Socket - Relay	16	125 6975	1	Ground Lug (1) Pole
6	021 6809	1	Relay (3HP AC Drive)	17	490 2642	1	Component Mounting Board
	021 6810	1	Socket - Relay	18	125 6970	1	Control Cabinet
7	125 6990	1	Circuit Breaker 30 Amps - AC Drive (2) Pole	19	121 8315	1	Notice - Warranty Decal
8	125 6994	1	Air Pressure Switch UL/CGA	20	123 8335	1	460V Decal
9	125 6976	1	3HP AC Discharge Speed Control	21	128 8705	AR	Wire Raceway Track
				22	490 6831	AR	Din Rail

# MOTOR CONTROL CABINET 2000 TOWER DRYER SOFT START 3Ø 460V W/REMOTE CABINET CONTROLS

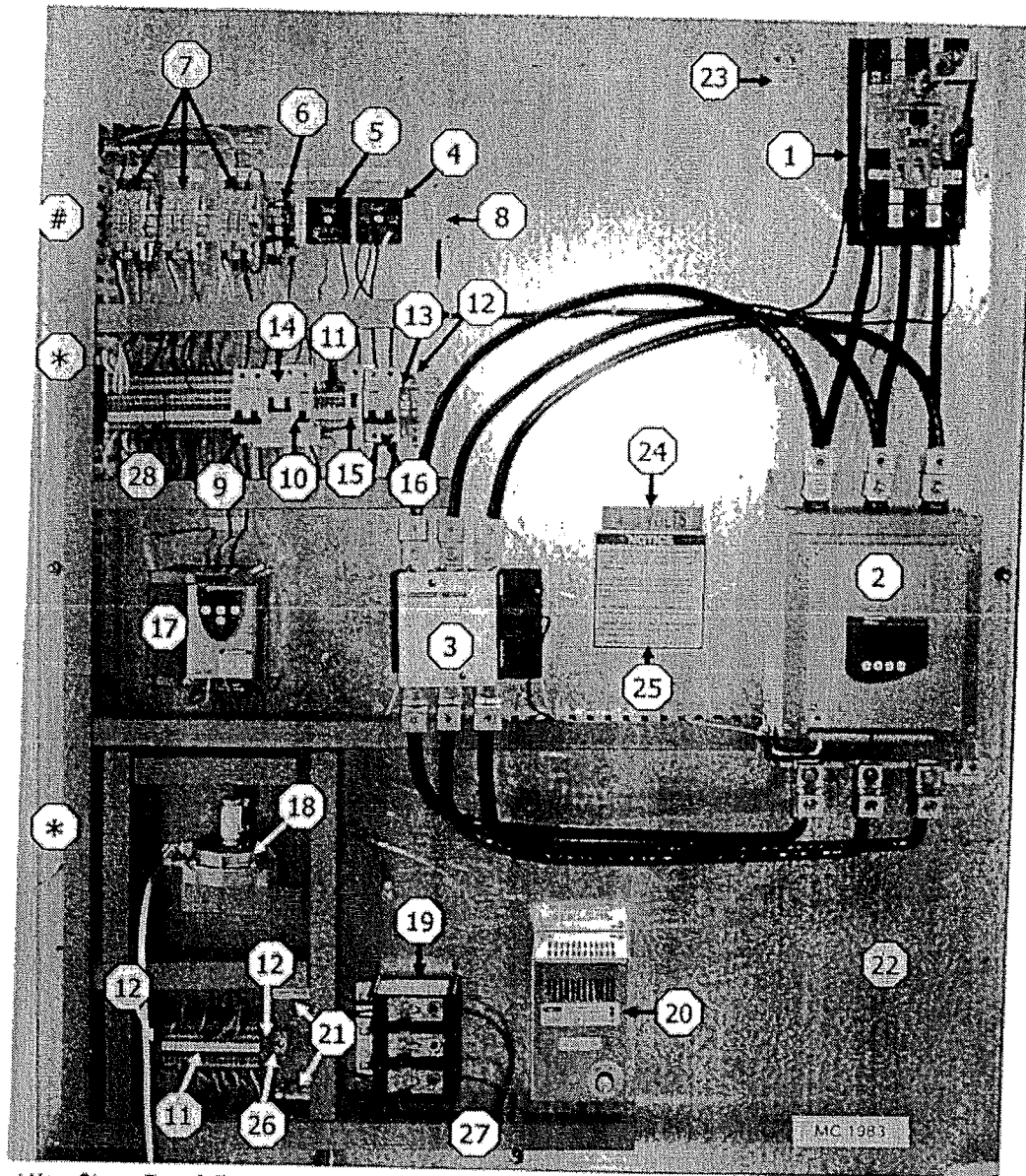

Ref. Part No.	Qty.	Description	Ref. Part No.	Qty.	Description
1	4906903	1 Disconnect Switch - Shunt Trip	12	4906833	4 Terminal End Retainer
	4906807	1 Door Mounted Handle & Mechanism	13	1257020	1 Neutral Terminal Block
2	1256969	1 Soft Starter 100HP 460V - IEC	14	1256993	1 Circuit Breaker 4 Amps (2) Pole (Panel Heater)
	4906808	1 Lug Kit (6)	15	1256998	1 Circuit Breaker .05 Amps (1) Pole (Soft Start Control)
3	1256858	1 Contactor - 150 amps - IEC	16	1256700	1 Circuit Breaker 25 Amps (2) Pole (Transformer)
	4906808	2 Lug Kit (3)	17	1256976	1 3HP AC Discharge Speed Controller
	1256855	1 Auxiliary (Interlock) Contact N.O.	18	1256994	1 Air Pressure Switch
4	475482	1 Time Delay Relay (3) Seconds	19	1286957	1 Distribution Block 115V
5	1246831	1 Time Delay Relay (10) Seconds (Ignition Purge)	20	1256974	1 Heating Unit for #1256858
6	1248954	1 Fill Relay	21	1256975	2 Ground Lug
7	0216809	3 Relay (Fan Control, LLC Alarm, & Discharge)	22	4902642	1 Component Mounting Panel 230/460V
	4906830	3 Relay Sockets	23	1256918	1 Ground Lug (2) Pole
8	1276812	1 Resistor - 3KΩ 10W	24	1238335	1 460V Decal
9	1256990	1 Circuit Breaker 30 Amp (2) Pole (AC Drive)	25	0018310	1 Warranty Decal
10	1256988	1 Circuit Breaker 8 Amps (1) Pole 115V	26	4906831	AR Din Rail
11	1257007	24 Terminal Block - Spring Wire	27	1288705	AR Wire Raceway Track 1" (2.54cm.)
	1257012	24 Terminal Marker Strip	28	1257010	23 Terminal Block - Spring 3 Wire
	1257006	2 Terminal End Plate		1257011	1 Terminal End Plate
				1257012	23 Terminal Marker Strip
				1257007	1 Center Jumper



MODEL 2000 & 2250  
SWEEP DISCHARGE SYSTEM (BASE SECTION)

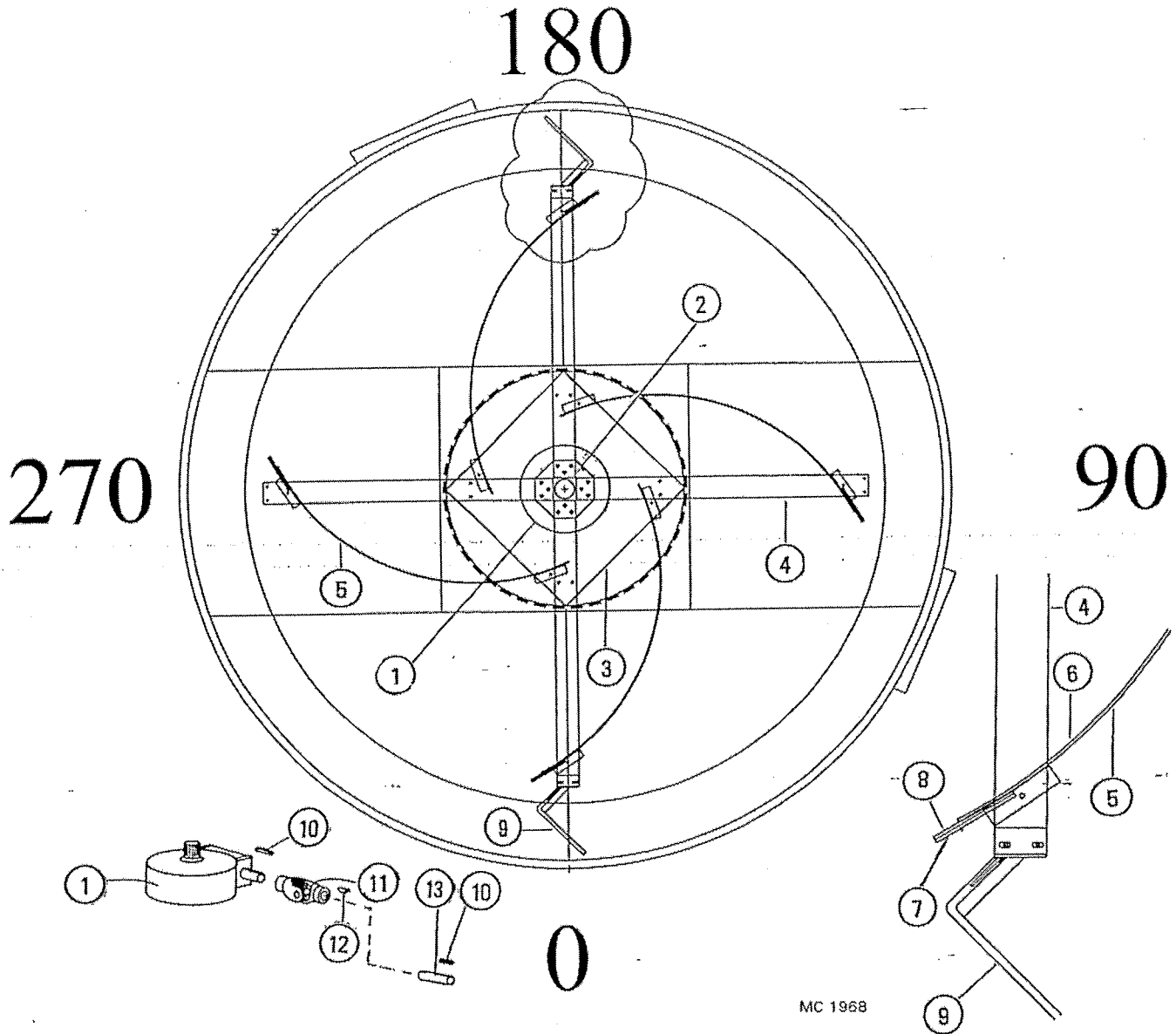

MC 1968

Ref.	Part No.	Qty.	Description
1	475 886	1	Gearbox 50.1
2	821 633	1	Hub - Sweep Arm
3	480 150	1	Sweep Arm Support
4	490 5200	4	Sweep Support Arm $\frac{1}{2}$ x 4 x 52 $\frac{3}{4}$ " (1.27x10x134cm) Alum.
5	490 0010	4	Sweep Arm
6	476 041	4	Sweep Arm Liner
7	833 278	4	Sweep Arm Finger
8	441 965	4	Cleaner Sweep $\frac{1}{4}$ x 2 x 7" (6.37 x 5 x 178mm)
9	821 364	2	Finger Sweep Arm
10	001 5120	2	$\frac{1}{4}$ x 1 $\frac{1}{2}$ " (6.35 x 38.1mm) Key
11	820 026	1	Universal Joint
12	122 8254	1	$\frac{1}{4}$ x $\frac{7}{8}$ " (6.35 x 22.2mm) Woodruff Key
13	490 5020	1	Sweep Input Shaft 1 x 20 $\frac{1}{4}$ " (2.54 x 57.4cm)

**SWEEP & DRIVE SYSTEM - 12 FT. (3.66m.)**  
**Starting w/Serial No. 58444**

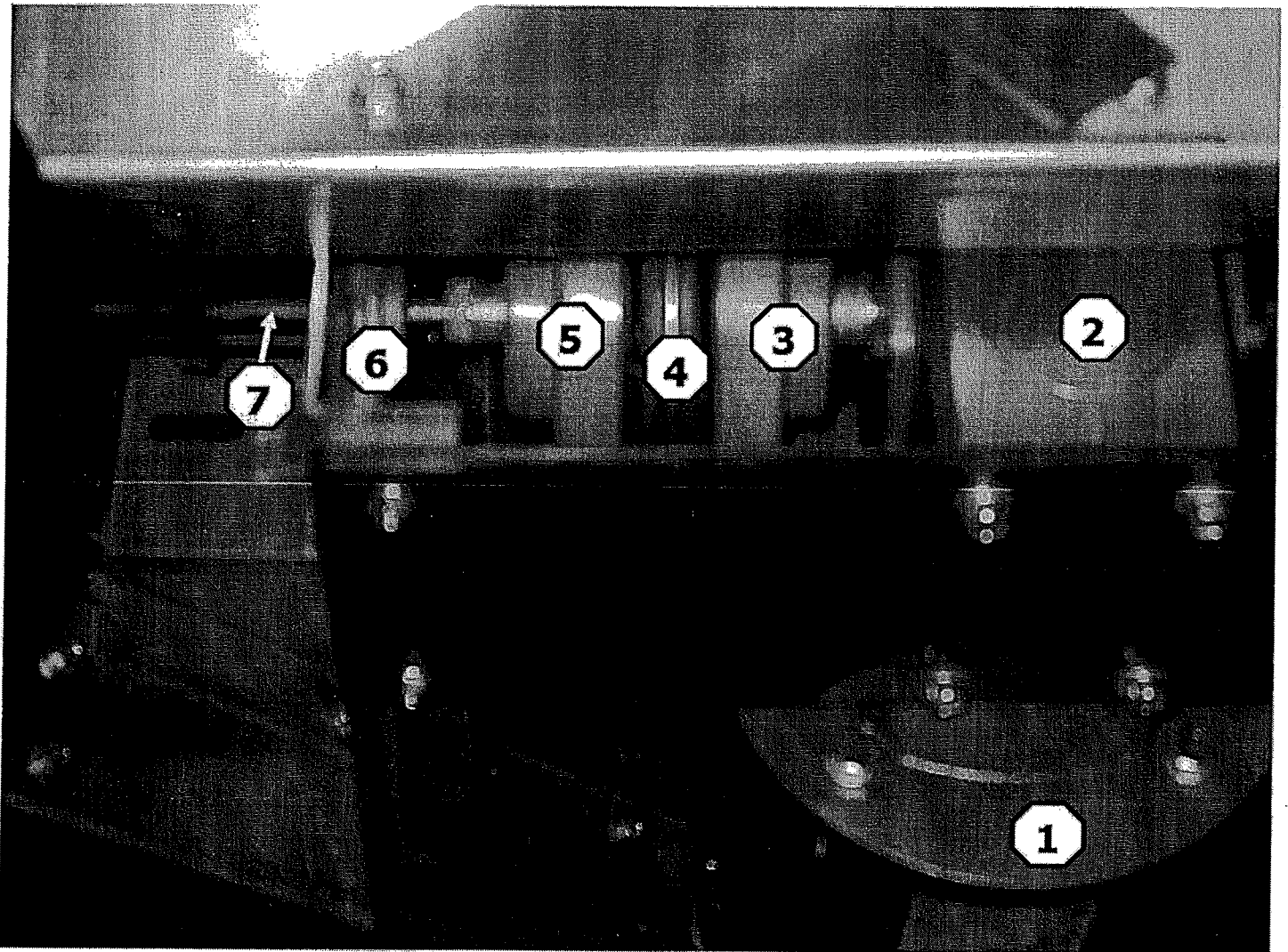

Ref.	Part No.	Qty.	Description
1	125 7023	1	3HP 3Ø 230/460 TEFC "C" Flange Motor
2	124 6821	1	Gearbox 5 to 1 Ratio (Drive Motor)
3	128 6624	1	Flange 8S 1½" (28.575mm.) I.D.
4	128 6626	1	Sure Flex Sleeve 8E
5	128 6625	1	Flange 8S 1" (25.4mm.) I.D.
6	490 6000	1	1" (25.4mm.) 3 Bolt Flange Bearing
7	490 5020	1	1" x 20¼" (2.54 x 51.4cm.) Sweep Input Shaft
*	820 026	1	1" (25.4mm.) Universal Joint
*	475 886	1	Sweep Gearbox 50 to 1

\* Not Shown

# SECTION 1 - BASE

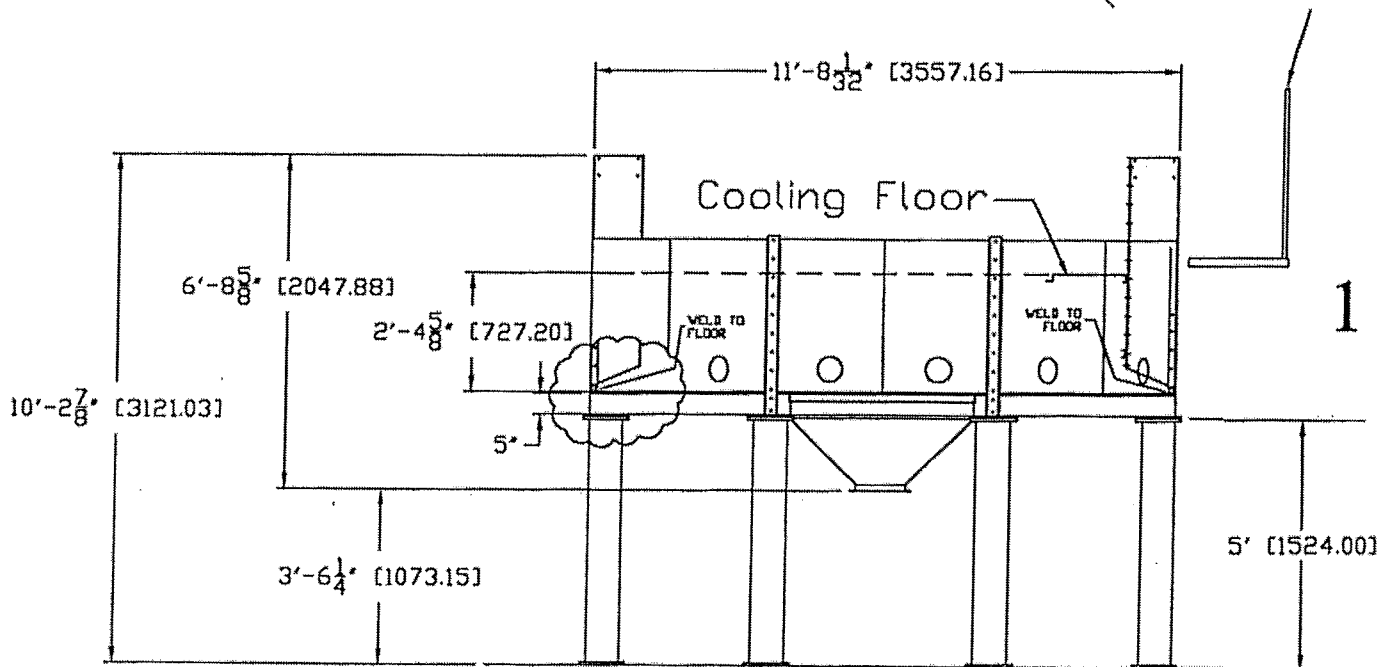
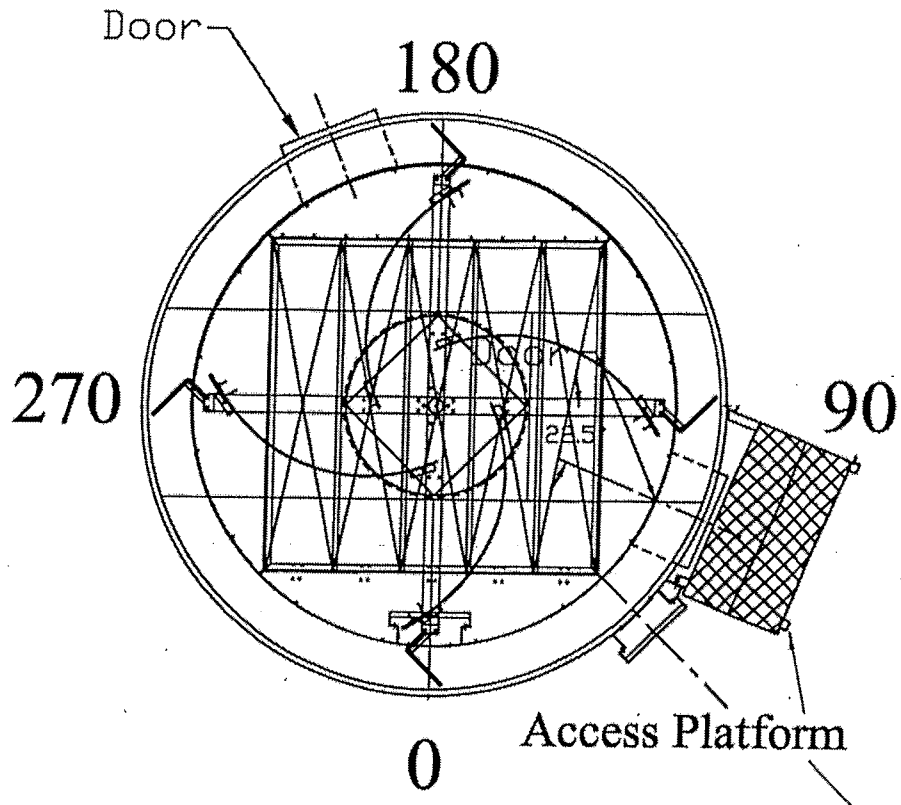



# SECTION 2 - DOORS

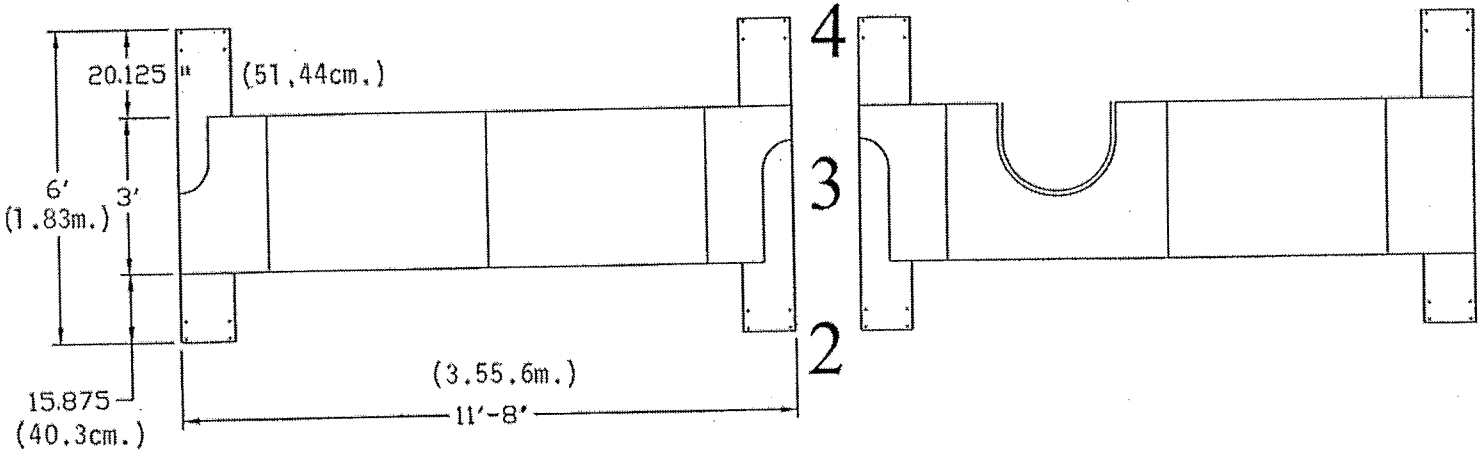
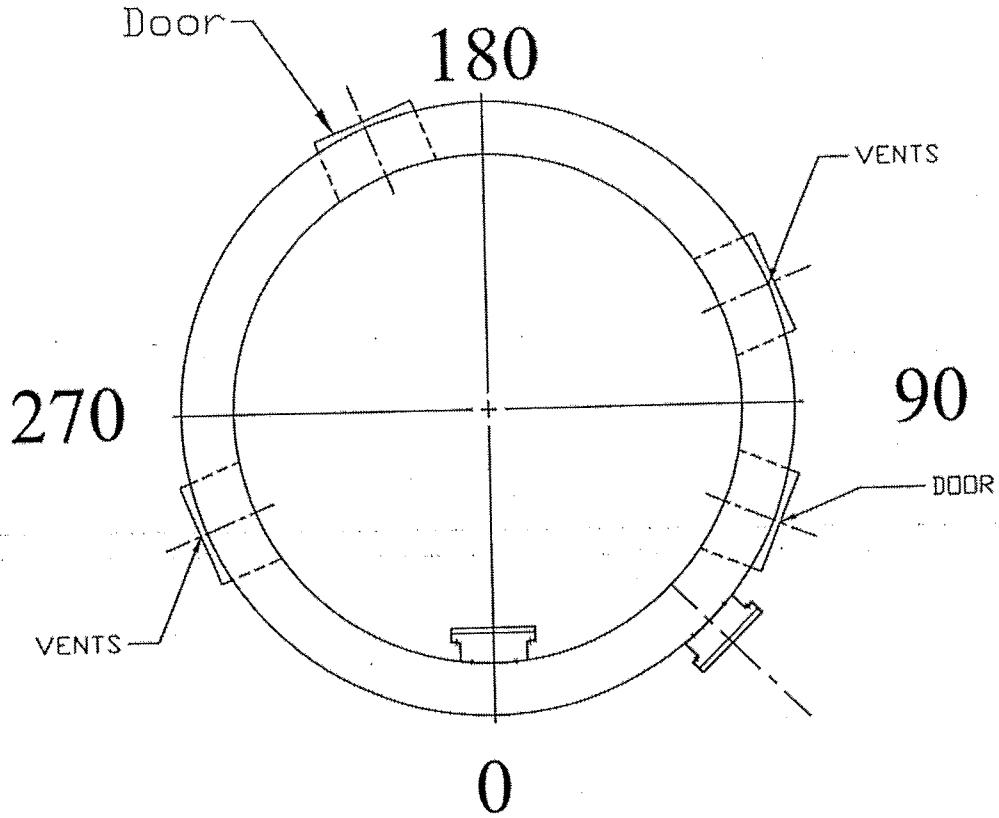

# SECTION 3 - FAN

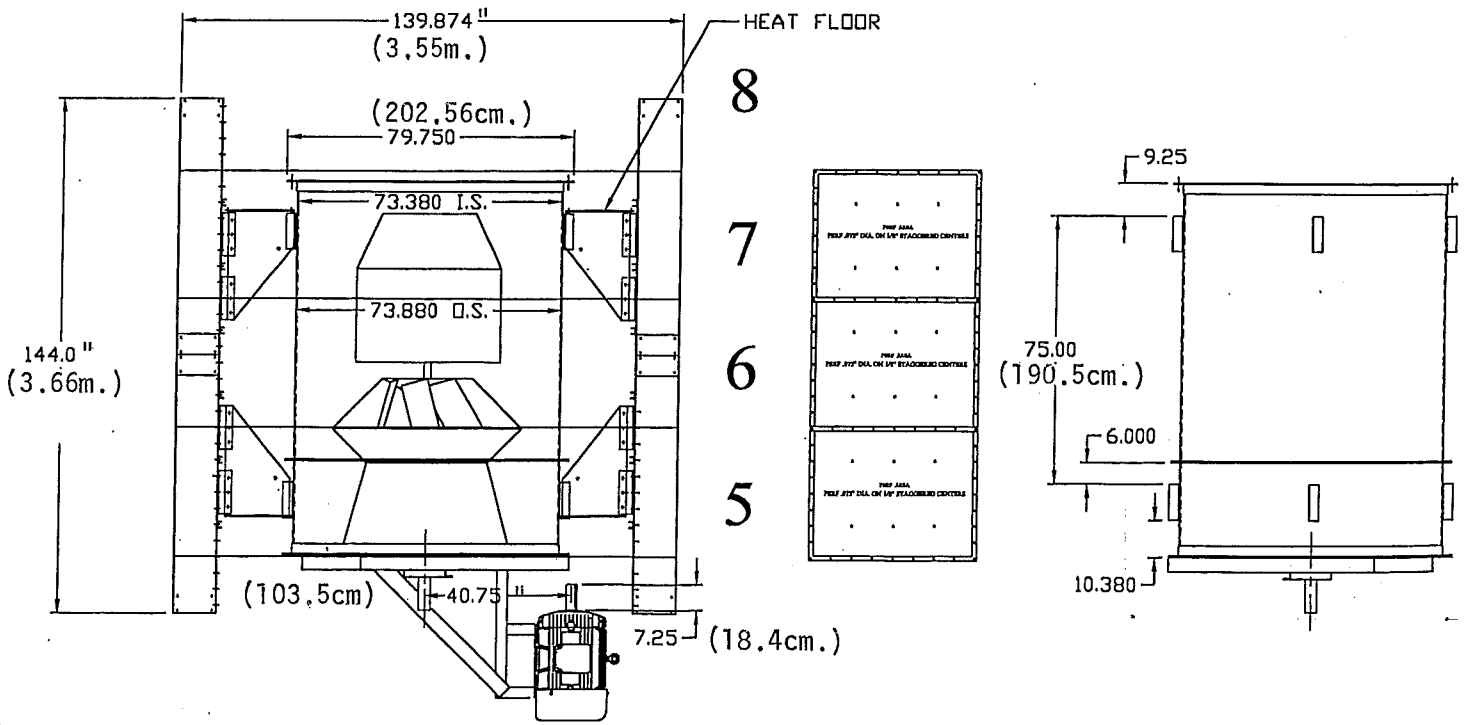
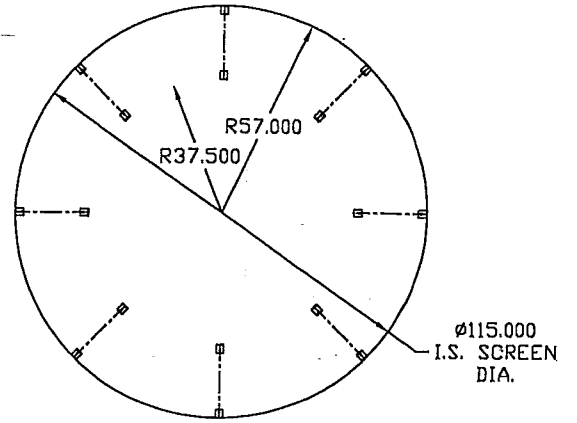
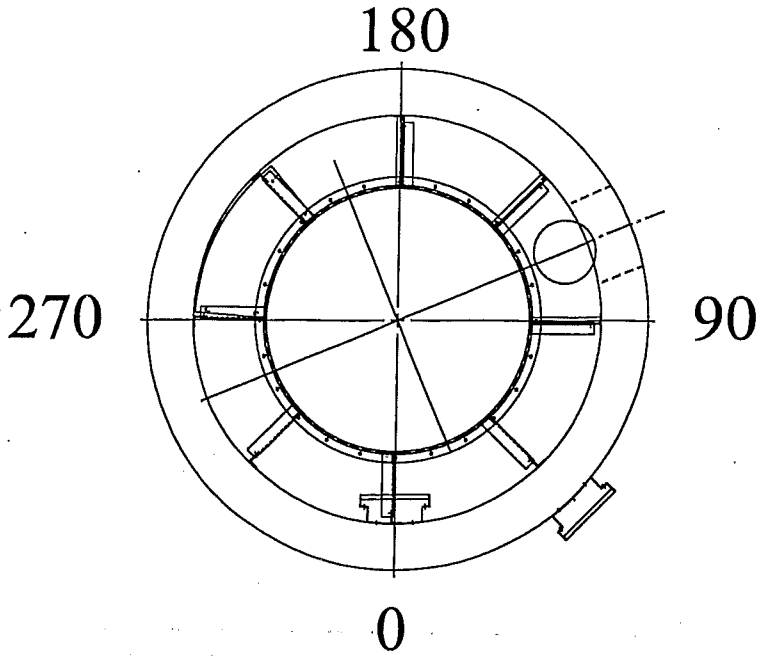

# SECTION 4 - SMALL INSIDE PLATFORM

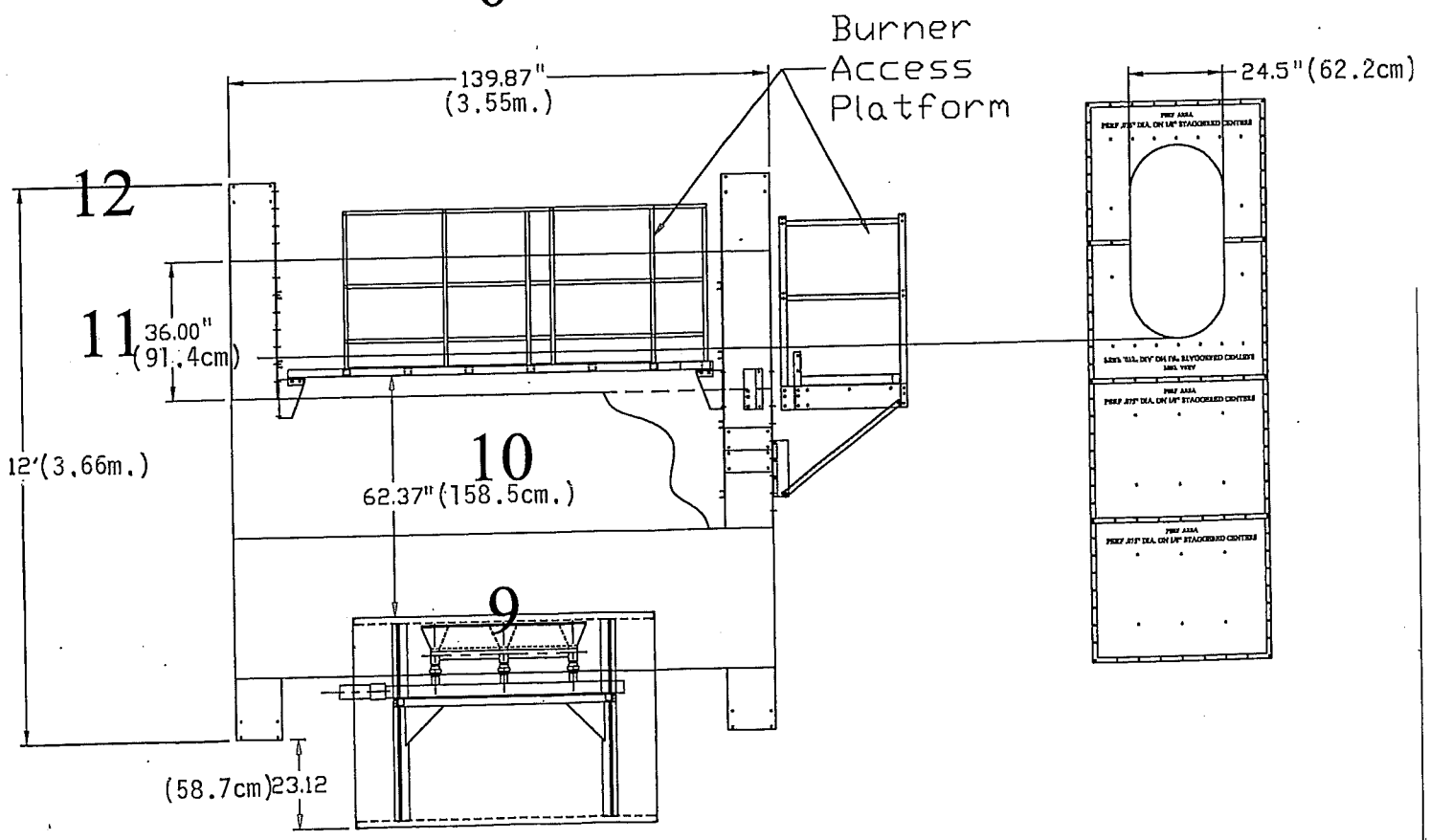
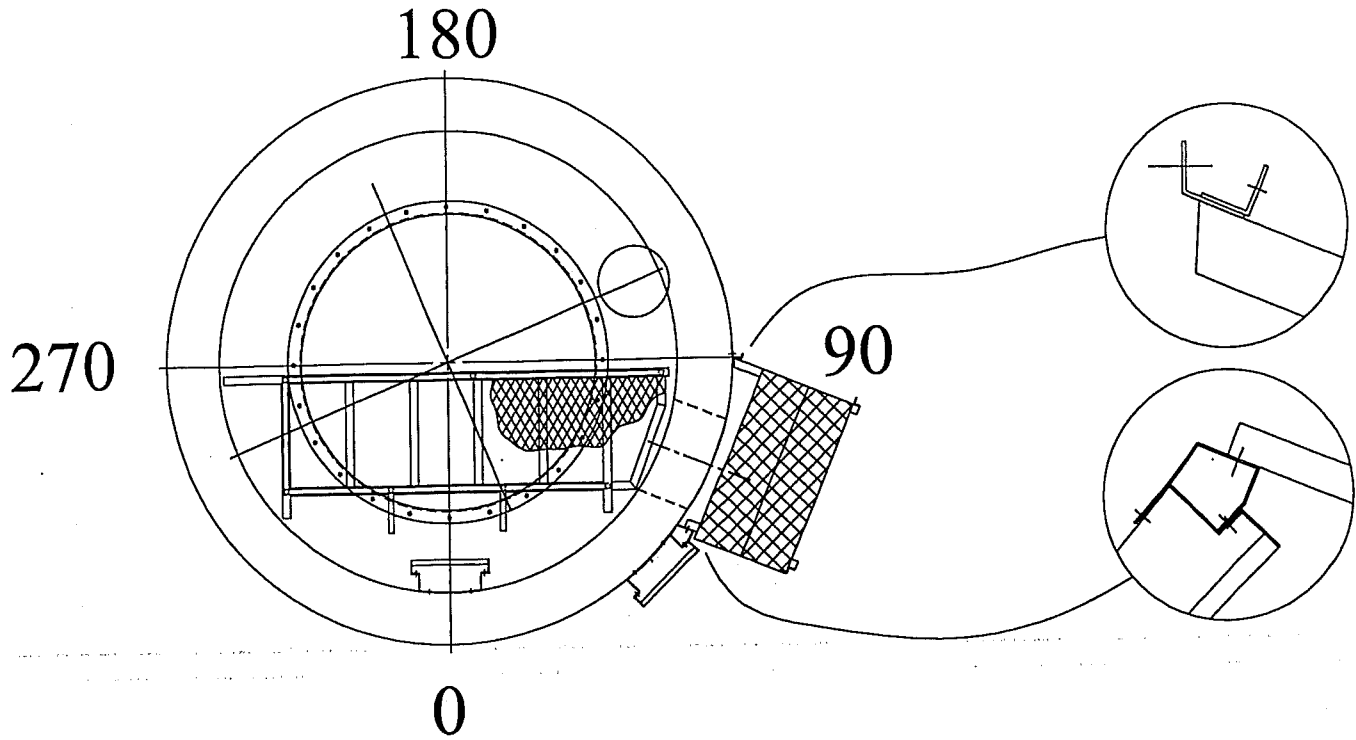

# SECTION 5 - GRAIN TURNER 180

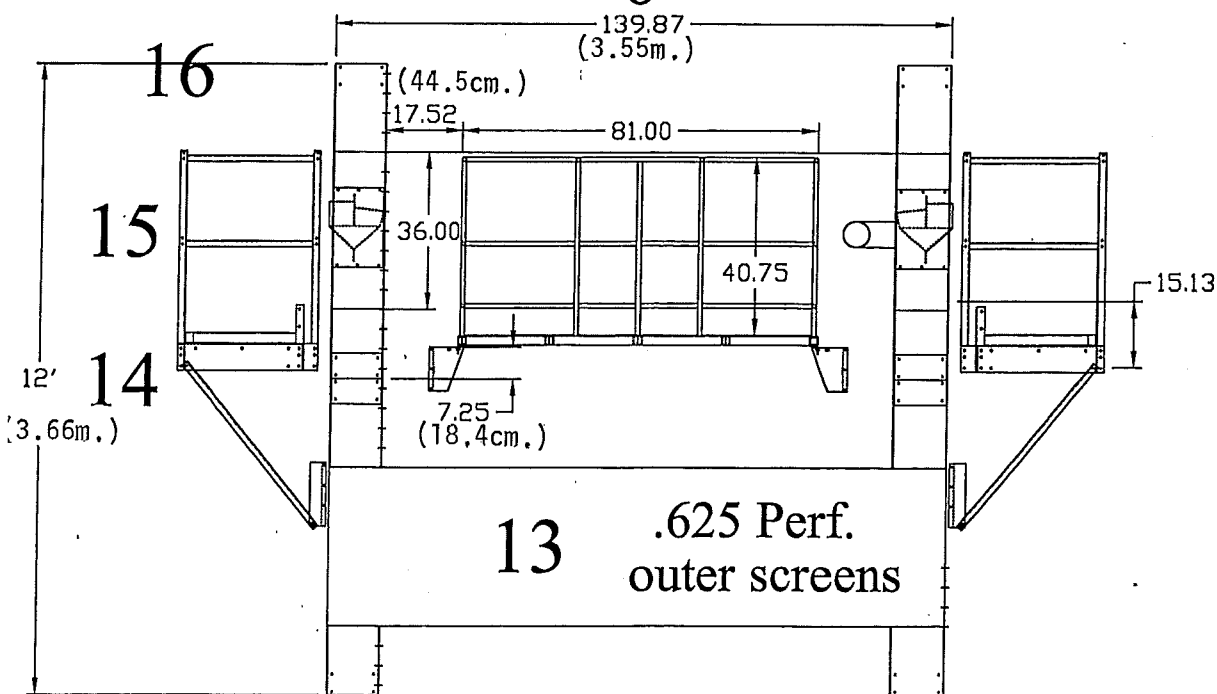
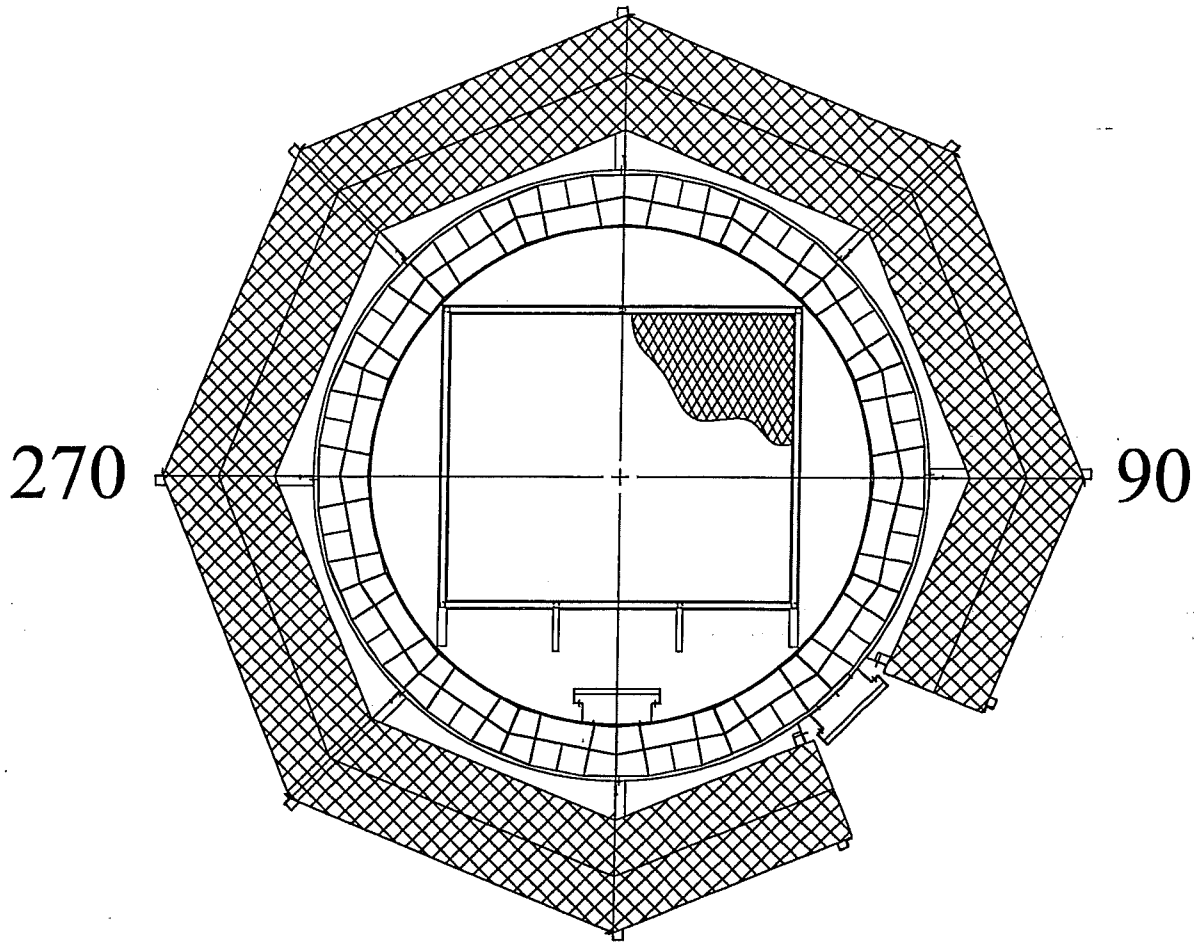

INSIDE SCREENS

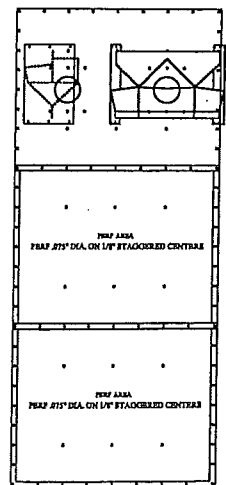

# SECTION 6 - INSIDE WALKWAY TOP SECTION

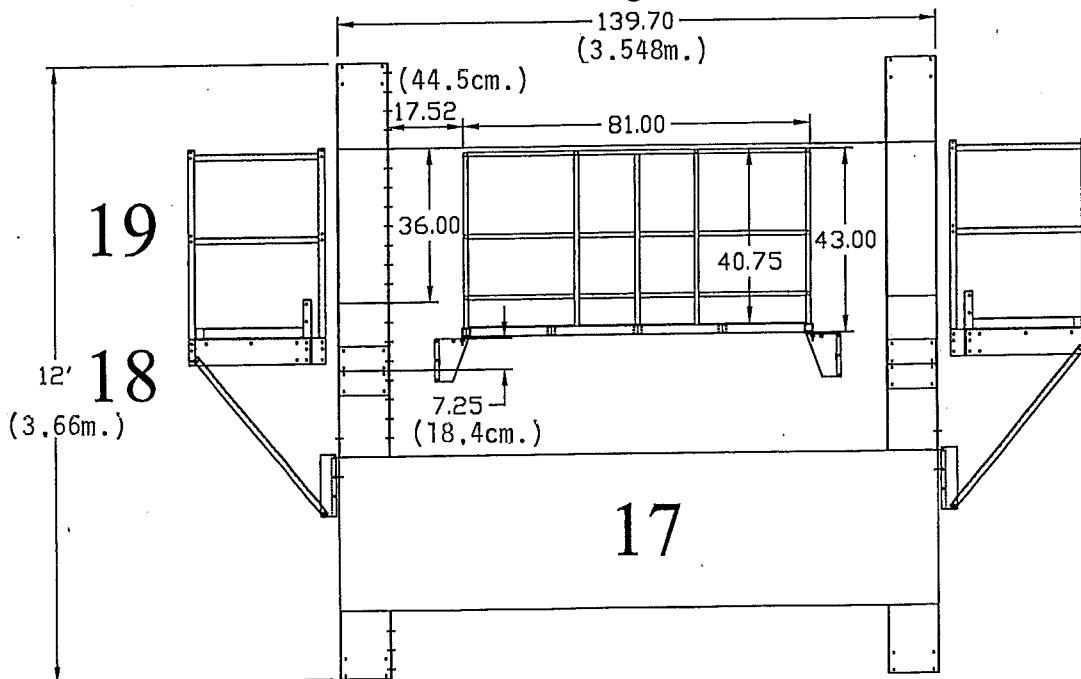
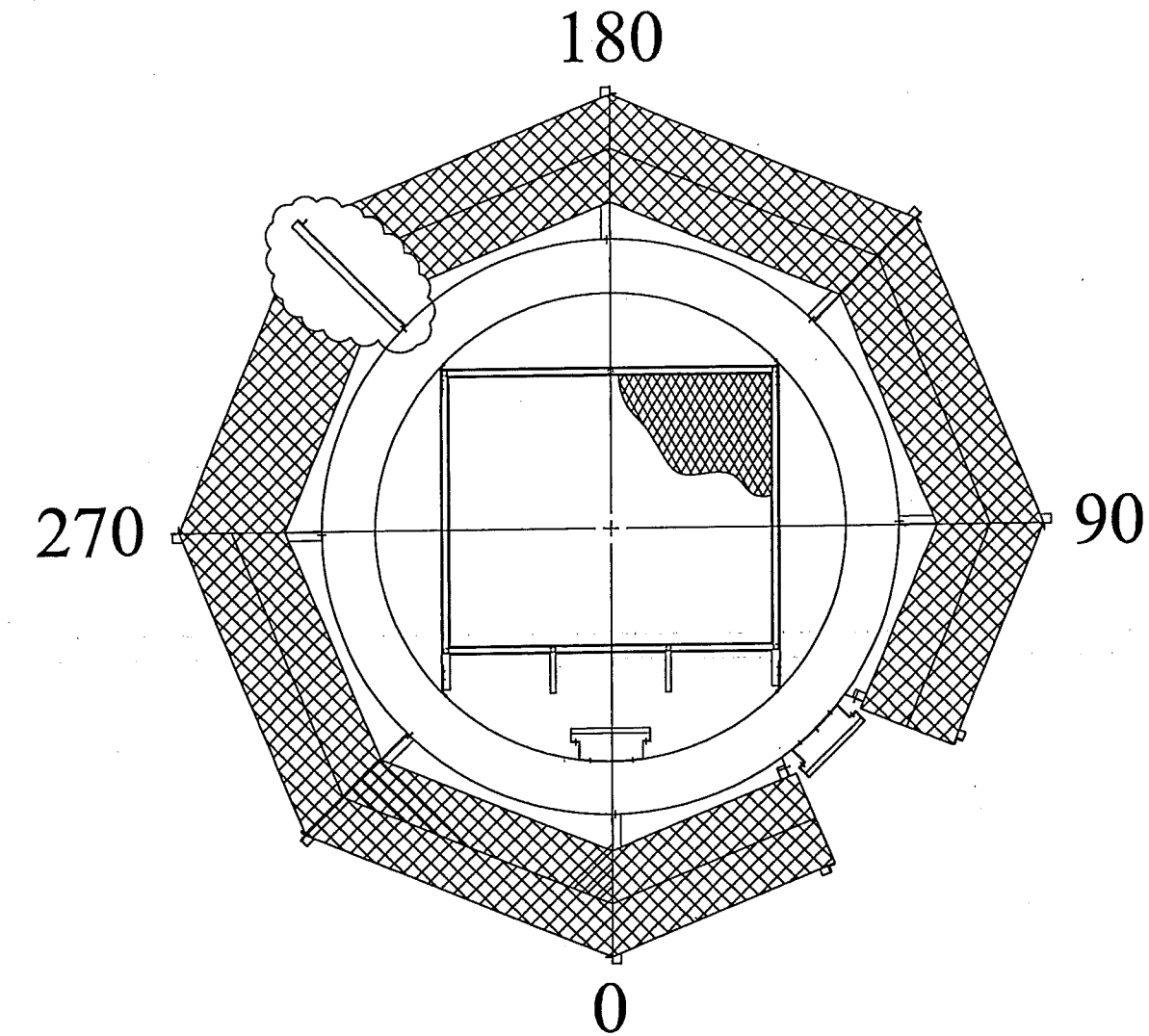

INSIDE SCREENS

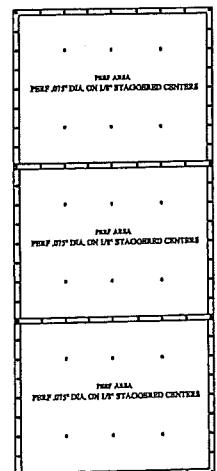

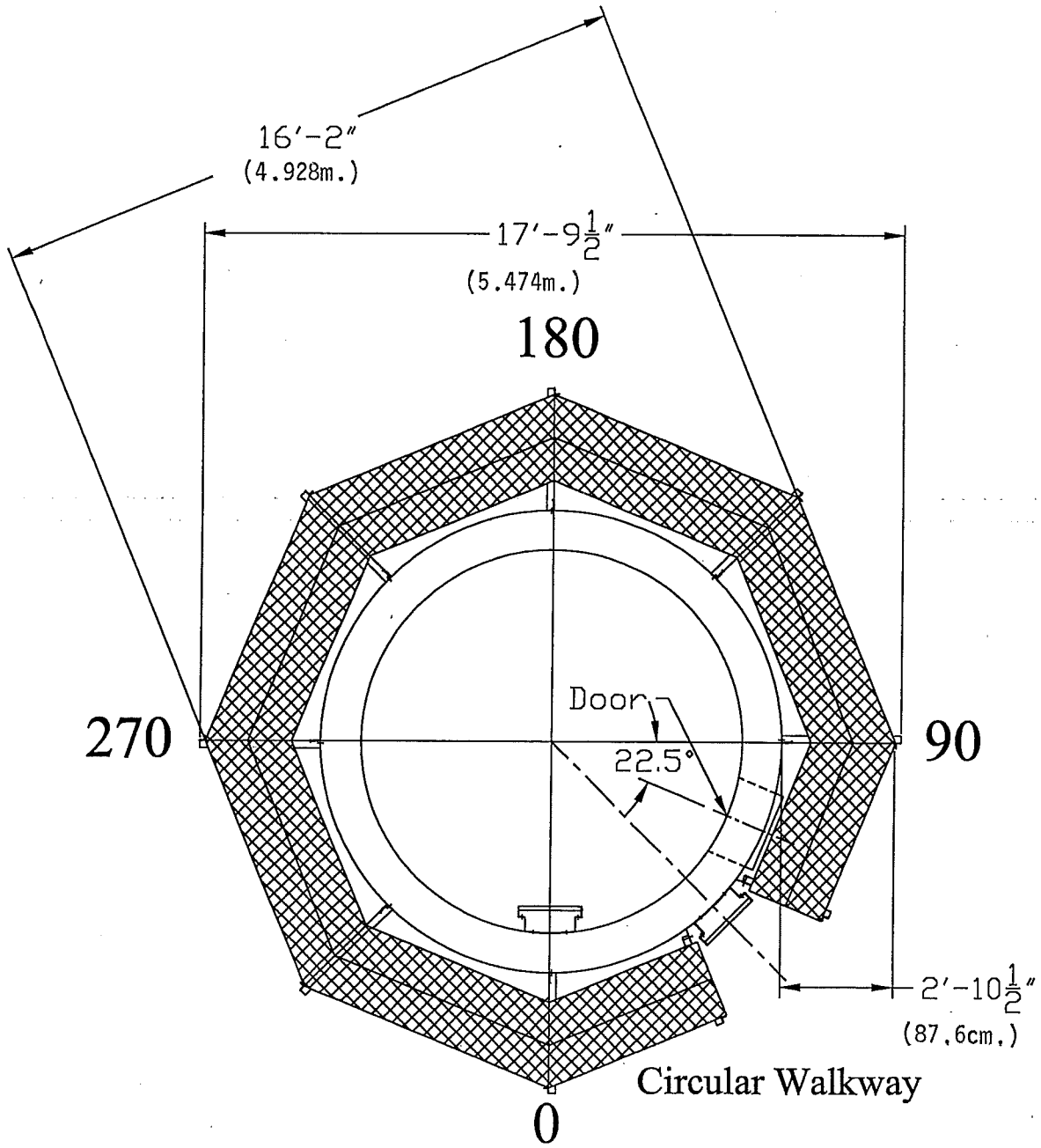

# SECTION 7 - ROOF SECTION

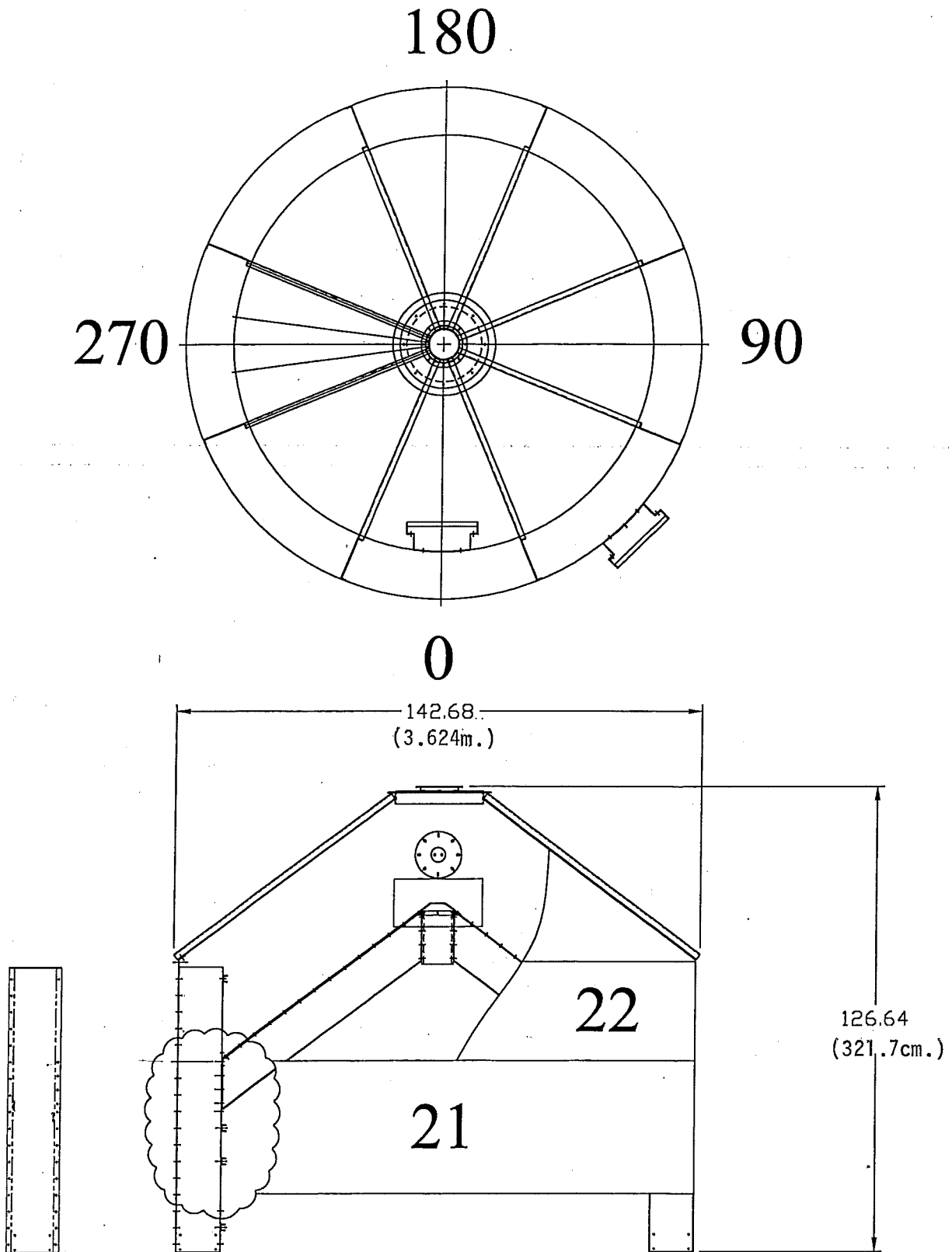

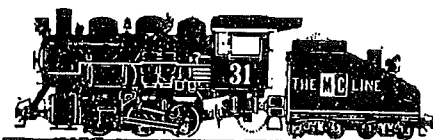

*Iron Horse Quality*