

TAKES THE WORK OUT OF LAWN AND ESTATE CARE

Price \$1.50

lawn genie

FLAIL PICKUP MOWER



OPERATOR'S MANUAL

MODEL LG36 Serial No. 34990 thru 36854

MANUFACTURED UNDER PATENT NO. 3,633,349; 3,693,335 OTHER PATENTS PENDING.

B.C. Mathews Co./ • CRYSTAL LAKE, ILLINOIS 60014 • U.S.A. •
PRINTED IN U S A. Reprint 78 (Rev. 7-84)

READ ALL INSTRUCTIONS BEFORE OPERATING MACHINE

OPERATING INSTRUCTIONS

The LAWN GENIE is a flail type mower with a combination mowing and pick-up feature. It is used for mowing, thatching, and clean-up work. Picking up grass trimmings and leaves in the spring and fall is an easy chore because of its hopper and basket arrangement.

For best results, the operation of the LAWN GENIE should be clearly understood. The rotor is a large diameter tube with 38 patented hangers with two patented replaceable swinging knives to each hanger. These high carbon steel hangers and knives are arranged in four evenly spaced rows across the length of the rotor to give uniform cut the full width of the mower. SEE ILLUSTRATION A Page 2.

The hangers are fastened to the rotor with special lock nuts. These lock nuts draw up tight enough to securely hold the hanger and knives, yet loose enough to allow the hanger and knives to swing easily.

The LAWN GENIE, with its own 8 H.P. gasoline engine is rugged enough to use in a variety of ways as anyone will find out after using it for a short time.

The engine is equipped with a centrifugal type clutch pulley. When the engine is idling, the clutch pulley is disengaged. When you apply full throttle, the centrifugal force engages the clutch pulley to drive the rotor.

A safety guard has been installed on each side of the machine to guard against the operator's foot getting caught in the cutting mechanism and also to prevent a tire from being hooked around a tree or fence post. Do not remove these guards.

Pole Adjustment: The LAWN GENIE should run level with the tractor for the best cutting job. The hitch tongue adjusts in three positions. Bolt the tongue in any of three pivot holes under the front of the machine to level it with the tractor and ground.

Damper Adjustment: To mow and load the clippings, pull the damper rod on the side of the throttle mount forward. To mow only, push the damper rod back. This opens or closes the damper gate which allows clippings to travel up the hopper and into the basket or directly back to the ground.

MOWING

For normal lawn mowing you can easily set the cutting height by turning the crank on the left front side of the machine. It is best to set the height so that the rear roller clears the ground and only engages when you encounter a rise or dip in the surface. This roller is to help eliminate scalping.

When cutting heavy grass from 4-6" in height your ground speed should be slower than if the grass were only 2" high. Determine the type of job you have and govern your cutting speed accordingly.

When cutting fresh and tender or wet grass, it may be difficult to dump the basket because of the extra weight. Under these conditions it is advisable to only partially fill the basket before dumping it.

If you wish to pick up wet grass, do it in a two-part operation. Close the damper by pushing the control rod mounted on the throttle console. This will direct the grass clippings back onto the ground. Later, go back and pick up the grass when it has dried.

THATCHING

To thatch and pick up old dead grass, you may cut directly and load into the basket or deflect the material to the ground and then come back and pick it up later. Normally for a thatching operation set the cutting height so that the roller is in direct contact with the ground.

LEAF CLEANUP

An important feature of the LAWN GENIE is its ability to do the back-breaking job of leaf removal. Mowing with the standard machine will cut up the leaves and decrease their volume for pickup. They can be dumped and composted or bagged for removal.

A leaf grinder attachment is available which can easily be inserted in the rear portion of the LAWN GENIE. (See illustration — Page 6). With this low cost attachment, leaves are cut up or mulched enough to be left on the ground to disintegrate and disappear into the soil.

If you choose to pick up the mulched leaves, pull out the damper push rod, go back over the lawn and load the leaves into the basket. It is not necessary to remove the grinder attachment for this part of the operation.

MAINTENANCE — ALL MAINTENANCE MUST BE DONE WITH MOTOR OFF

CLUTCH and BEARINGS

The drive clutch, rotor bearings, and ground roller bearings can be serviced by replacement only.

BASKET

If the basket's fabric becomes mutilated or badly worn, a new plastic fabric is easily snapped into place. Purchase from your LAWN GENIE dealer.

BELT ADJUSTMENT

It is important to have the engine up to speed and the belt tight on the pulley in order to provide the traction necessary to drive the rotor. If belt slippage occurs, immediately stop the engine and check the belt tension. Tighten the belt by increasing the tension on the spring tightener.

If the rotor does not turn, check the drive belt. If the drive belt is tight and the rotor does not turn, the rotor is likely jammed by some field debris and requires clearing. Be sure engine is shut off.

CLEANING

When cutting wet grass, the grass may build up on the underside of the machine. It is recommended that you hose down the housing, hopper and rotor after use. A clean hopper provides a smooth flow for the material to the basket.

KNIVES and ROTOR

The knives can be reversed to expose a new cutting edge. If necessary, the knives can be removed and sharpened on any electrical bench grinder.

The rotor must not be run with knives missing. If knives are lost or missing, the rotor will be out of balance and the machine will vibrate. If this happens, stop the engine and inspect the knives by lifting off the basket and opening or removing the rear inspection cover. Refer to Mathews Company Parts List if replacements are necessary.

TIRES & WHEELS

Tire pressure must be equal in order to obtain an even cut. Grease the wheel bearings once a year with grease fitting on the wheel.

ENGINE

The engine manufacturers manual clearly illustrates all Operating and Maintenance Instructions for the engine. (Enclosed in Warranty Envelope).

HEIGHT ADJUSTMENT CRANK

A few drops of oil on the bearing and screw will ensure easy, quick adjustment.

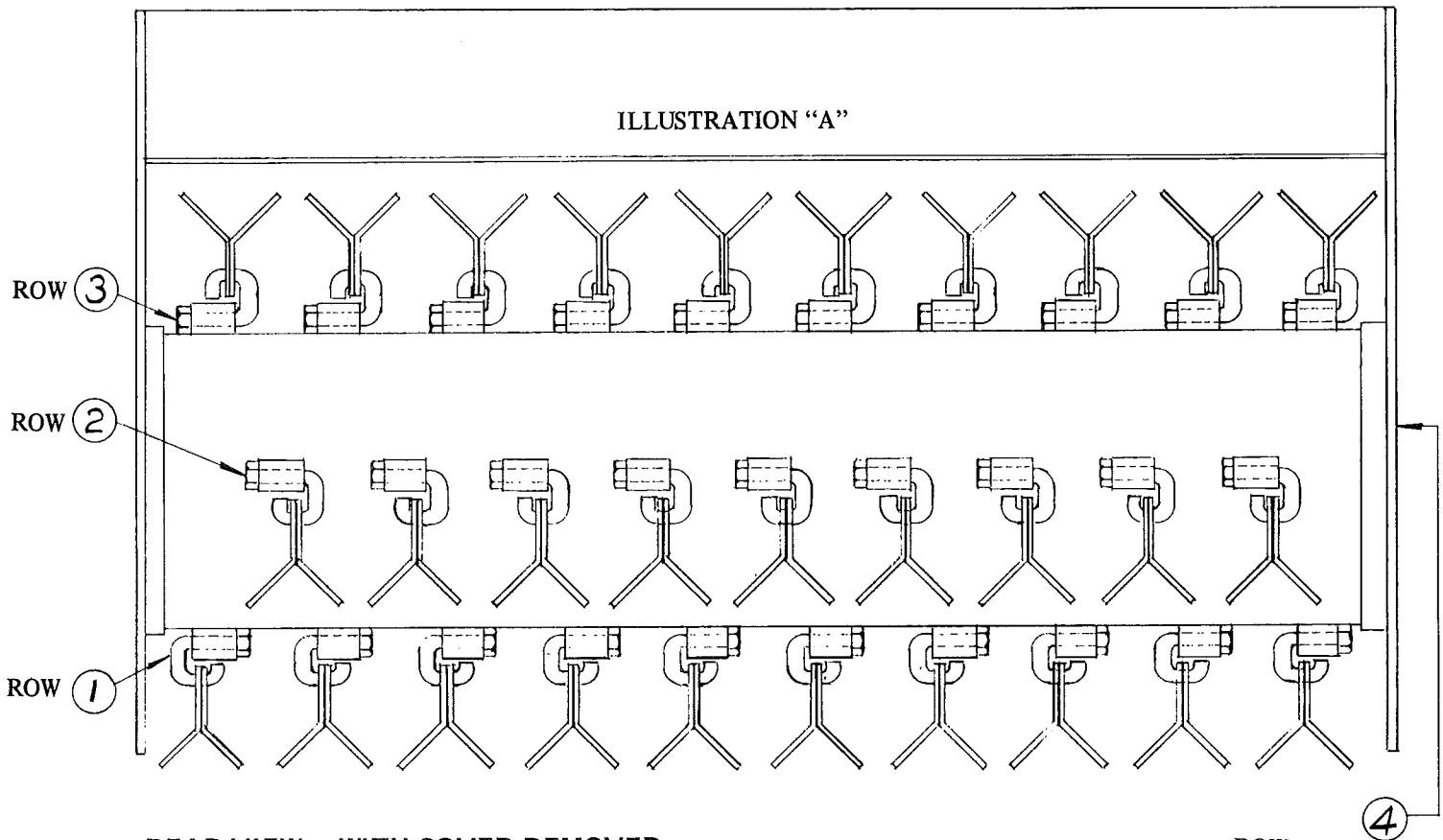

REAR VIEW – WITH COVER REMOVED

- Row 1 – All hanger threads (11) pointed to the right
- Row 2 – All hanger threads (10) pointed to the left
- Row 3 – All hanger threads (11) pointed to the left
- Row 4 – All hanger threads (10) pointed to the right

ROW
(Not Shown)

LG36
PARTS LIST

REF. #	PART #	QTY.	DESCRIPTION	REF. #	PART #	QTY.	DESCRIPTION
1	0008132	2	3/8-16x3½ HHCS	55	1318999	1	Knob
2	1310077	1	Pole	56	1318100	1	¼-20x2½" Eye Bolt
3	1318985	1	Wind Flap	57	1318987	1	Control Rod
4	1318500	1	8 HP Engine	58	0008249	1	Cotter Key 1/8x3/4
5	1316600	1	Clutch	59	1310008	1	Damper Panel
6	0016100	1	V-Belt Bx56	60	1310003	1	Damper Panel Crank
7	0015151	1	Key ¼x¼x2¼	61	1318990	1	Damper Spring 7"
8	0008166	1	5/16-18 Wing Nut	62	0018132	1	J Bolt 3/8-16x4"w3" Thd.
9	0018112	1	5/16 Tinnerman Nut	63	1318256	1	Idler Spring
10	1310018	1	Belt Guard	64	0008162	2	3/8-16 Hex Nut
11	0008108	1	5/16-18x1" HHCS	65	1315193	1	Roller Tie Rod
12	1313402	1	Engine Brace	66	0008137	2	½-13x1¼ HHCS
13	1318995	2	Collar	67	1315130	2	Axle Key 3/8x3/8x2½
14	1328998	2	Tire 13.500x6	68	0008121	4	3/8-16x1 HHCS
15	1310013	1	Tree Guard Right Side	69	0008167	54	¼-20 Whiz Nut
16	0016205	1	B 8.6 PD Sheave (SDS)	70	1318101	6	¼-20x3/4 Truss Head
17	0018163	1	Shoulder Bolt	71	0008290	1	3/8-16x1½ HHCS
18	0008175	4	1/2 Flat Washer	72	0008204	7	3/8-16 NY Lock Nut
19	0016200	1	Idler 4-5/8 O.D.x½ Bore	73	1334655	1	Chute Stiffener Right
20	0008170	1	1/2-13 Whiz Nut	74	1334654	1	Chute Stiffener Left
21	1310012	1	Tree Guard Left Side	75	1318300	1	Decal Lawn Genie
22	1310040	1	Idler Arm Weld.	76	1328997	2	Wheel Assy. w/2 #77
23	1310006	1	Wheel Mount Right Side	77	1326000	4	Brg. 3/4 I.D.
24	1314431	2	Stop Angle	78	0008210	6	¼-20 2-Way Lock Nut
25	1311007	1	Roller Assy. Inc.#65+#82	79	0008101	2	¼-20x2 HHCS
26	1315042	1	Mower Main Axle	80	1310010	1	Rear Access Cover
27	1314775	1	Upper Inside Panel	81	0008180	3	½ Lock Washer
28	1305000	2	Pivot Stud	82	1316003	2	Brg, Gauge Rolls 7/8 I.D.
29	1330025	1	Chute Side Right	83	0008213	38	¼"-20x½ Truss Head Screw
30	1334884	1	Chute Front Panel	84	1312945	1	Shim (Special) 3/4 I.D.
31	1318131	2	3/8-16x5/8 Sq.Cn.Pt.S.S.	85	0008173	9	5/16 Flat Washer
32	1314428	1	Cutoff Bar	86	0008222	5	5/16 Lock Washer
33	0008213	38	¼"-20x½ Truss Head Screw	87	0018115	4	5/16-18x2 Gr. 5 HHCS
34	0008170	2	½-13 Whiz Nut	88	0008159	4	5/16-18 Hex Nut
35	1330026	1	Chute Side Left	89	0008100	8	¼-20x3/4 HHCS
36	1314653	1	Rotor Access Cover	90	1310017	8	Vacuum Paddle
37	0016016	2	3 Bolt Bearing 1¼ I.D.	91	0008124	6	3/8-16x1¼ Carriage Bolt
38	1310016	1	Rotor Weld	92	1314662	2	Anti Wrap Shield
39	1318707	42	Knife Hanger	93	0008169	10	5/16-18 Whiz Nut
40	1314446	84	Knife	94	0008158	2	¼-20 Hex Nut
41	0008205	50	3/8-16 Flg. Mac Lock Nut	95	1318977	1	Grommet
42	0015118	1	Key ¼x¼x1¼	96	1338254	1	3/16x1" Roll Pin
43	1310007	1	Wheel Mount Left	97	1334445	*	Thatching Blade Optional
44	1313305	2	Locking Clip	98	0008174	2	3/8 Flat Washer
45	1310001	1	Body Weld	99	0008179	2	3/8 Lock Washer
46	0008223	2	3/16-24x3/8 Whiz Screw	100	0008237	6	5/16-18x3/4 Carriage Bolt
47	1310011	1	Console	101	0008106	4	5/16-18x3/4 HHCS
48	1318994	1	Clip-Rope Handle	102	0008224	2	3/16-24 Whiz Nut
49	1317000	1	Throttle Control	103	1318303	1	Decal (Turtle)
50	1310005	1	Ram Tube	104	1318302	1	Decal (Rabbit)
51	1310039	1	Crank Mount Bracket	105	1318301	1	Decal (Ground-Hopper)
52	1316000	1	Ram Bearing	106	1318993	2	Wheel Assy, Inc.#14,76,77
53	1315175	1	Crank Screw	107	1311033	1	Crank Screw Assy.
54	1318991	1	Handle Crank Screw	108	1216246	1	Taper Lock Bushing 1¼"

*NOTE: See instructions for quantity used.

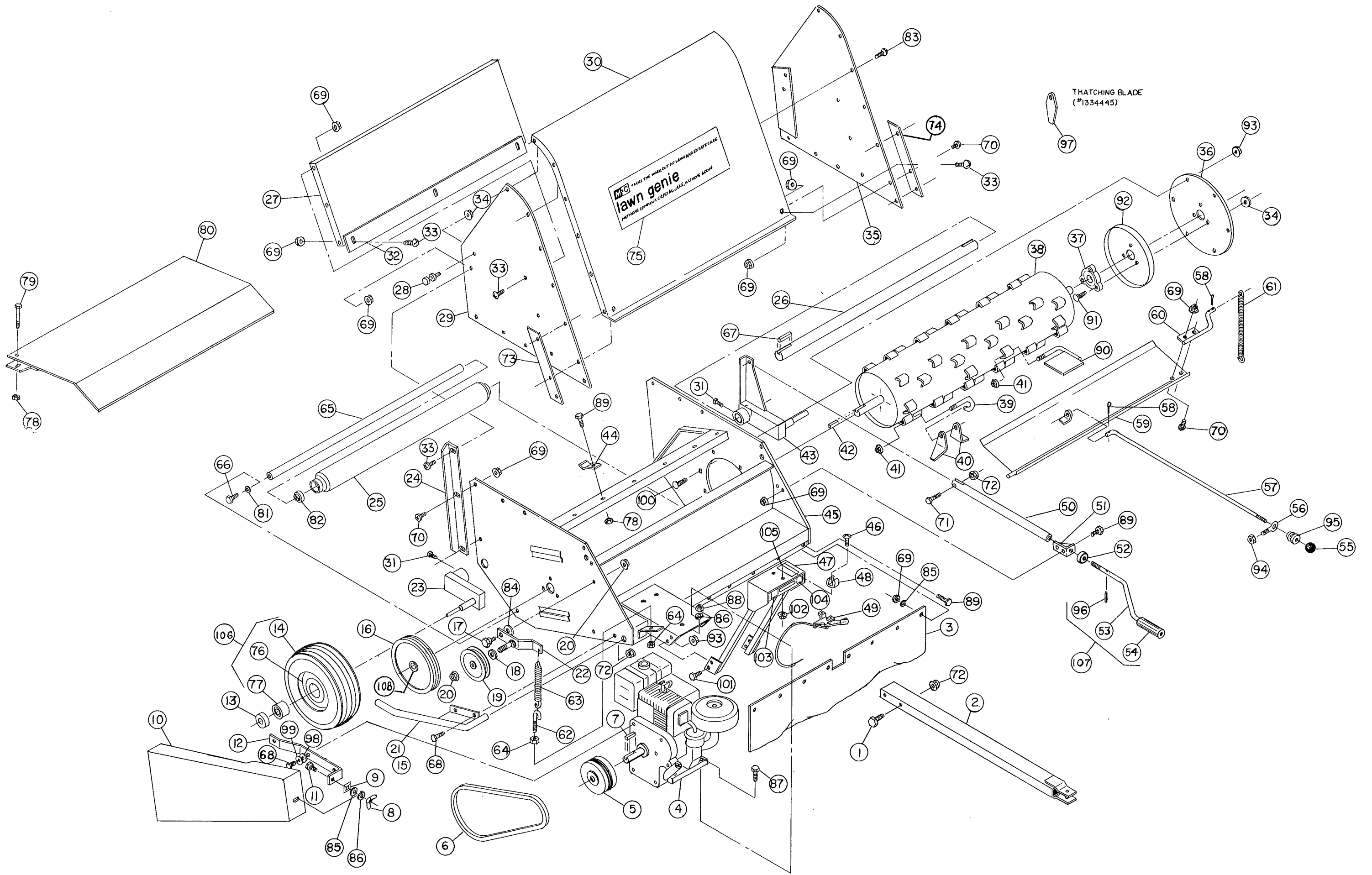

MAKES THE WORK OUT OF LAWN AND ESTATE CARE
lawn genie
LAWNSHOPS COMPANY, C. CENTRAL AVE., J. LAHORE 64204

THATCHING BLADE
(#1334445)

L36 CHUTE & HOPPER ASSEMBLY

KIT #1339014 (See Note)

<u>REF.</u> <u>NO.</u>	<u>QTY.</u>	<u>PART NO.</u>	<u>DESCRIPTION</u>
1	1	1330025	Chute Right Side Weldment
2	1	1330026	Chute Left Side Weldment
3	1	1334884	Chute Front Panel
4	2	1314431	Stop Angle
5	1	1334655	Chute Brace-Right
6	1	1334654	Chute Brace-Left
7	1	1318300	Lawn Genie Decal
8	2	1305000	Pivot Stud & Nut
9	1	1314775	Inside Chute Panel
10	1	1314428	Cut Off Bar
11	1	1334774	Bottom Hopper Rail
12	1	1334452	Channel Stiffener
13	1	1331005	Fabric Assembly
14	1	1312601	Pivot Bracket R.H.
15	1	1312602	Pivot Bracket L.H.
16	1	1312830	Gusset R.H.
17	1	1312831	Gusset L.H.
18	1	1332000	Front Bow
19	1	1313304	Top Center Bow
20	2	1318978	Link
21	2	1332001	Upper Brace
22	2	1312005	Side Strap
23	2	1315593	Side Post
24	1	1313072	Hopper Side Panel (Right)
25	1	1313071	Hopper Side Panel (Left)
26	1	1334880	Hopper Rear Panel
29	1	0015998	Rope
30	1	1318992	Handle

NOTE: 1331007 Hopper Assembly Only
1331008 Chute Assembly Only

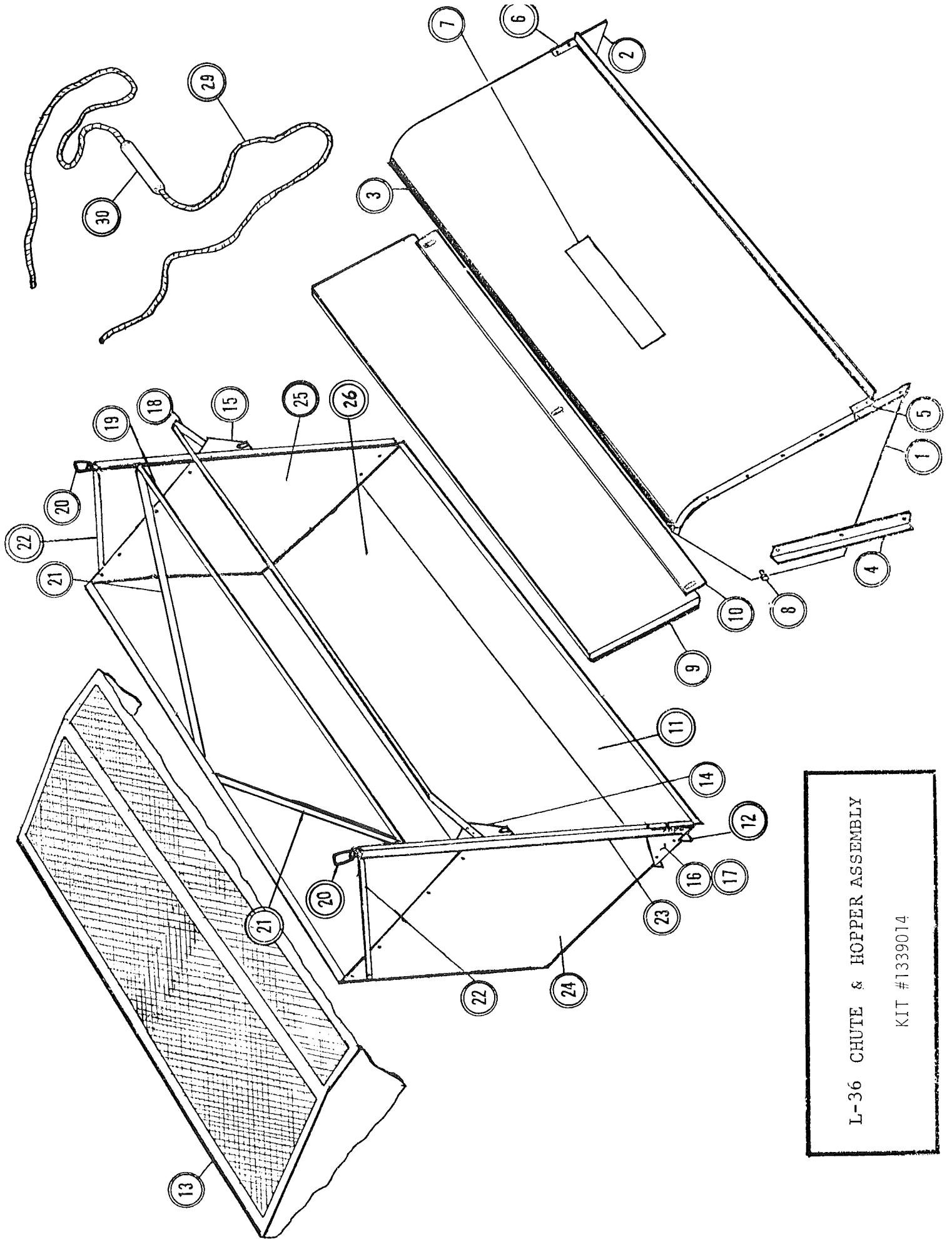

L-36 CHUTE & HOPPER ASSEMBLY
 KIT #1339014

L36 LEAF MULCHING SCREEN

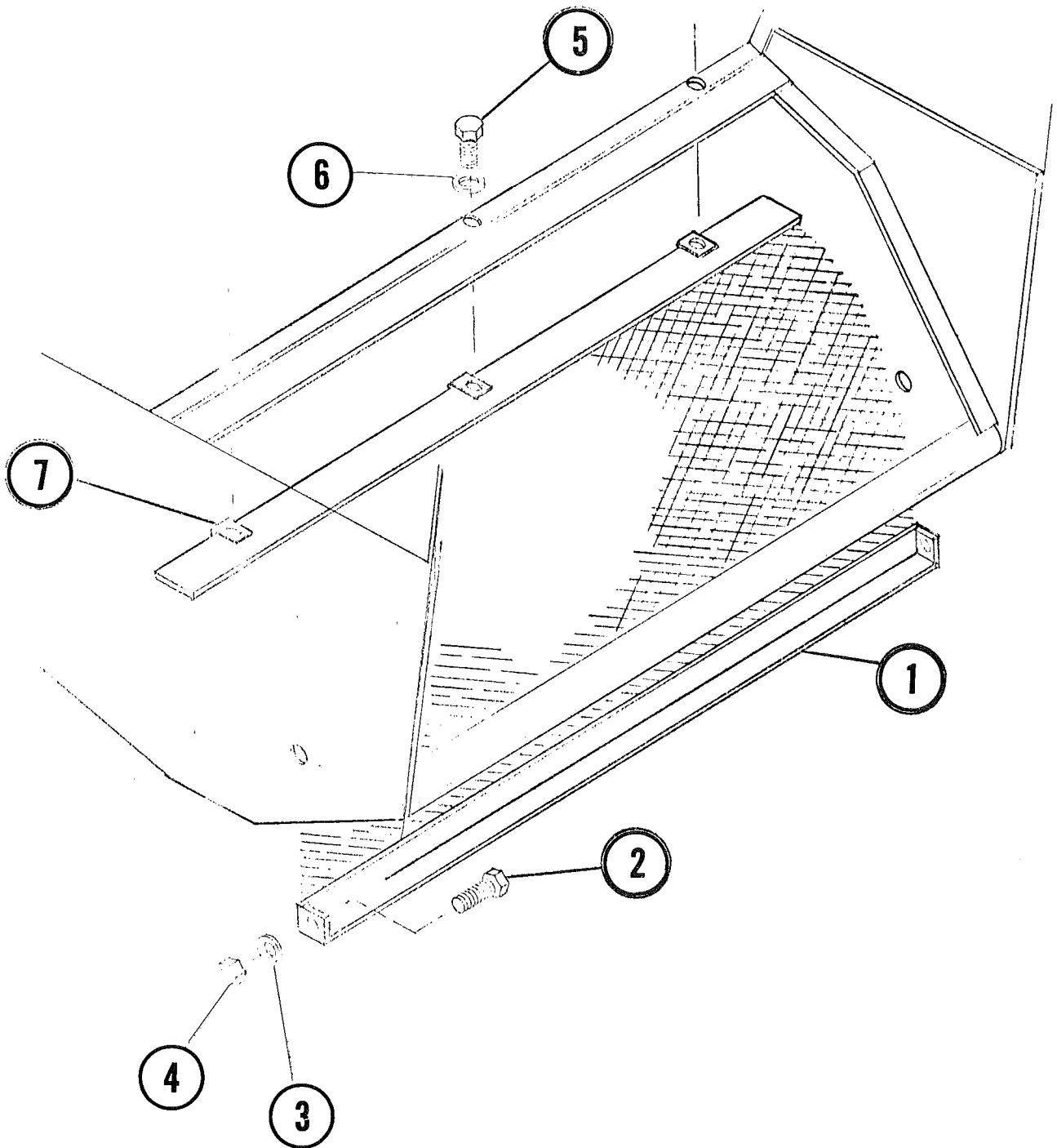

Ref. No.	Qty.	Part No.	Description
1	1	1330001	Leaf Mulching Screen
2	2	0008121	3/8"-16 x 1" Hex Bolt
3	2	0008179	3/8 Lockwasher
4	2	0008162	3/8-16 Hex Nut
5	3	0008108	5/16-18 x 1" Hex Bolt
6	3	0008173	5/16 Flatwasher
7	3	0018111	5/16-18 "U" Nut Retainer

Notes

INSTRUCTIONS FOR ORDERING PARTS:

1. ALL PARTS MUST BE ORDERED FROM YOUR DEALER.
2. GIVE MODEL NUMBER and SERIAL NUMBER that is stamped on the NAME PLATE of your machine.
3. Order from your PARTS LIST, found below each illustration, as this is the ONLY means we have of identifying the parts you need. Order by the QUANTITY DESIRED, the PART NUMBER and the DESCRIPTION OF THE PART.

NOTE: The Company reserves the right to incorporate any changes in design without obligation to make these changes on units previously sold.



OWNERS NOTICE

**TO INSURE WARRANTY CLAIMS, BE CERTAIN TO FILL
OUT AND MAIL WARRANTY CARD WITHIN 30 DAYS.**

PRINTED IN U.S.A.