

Model 144 SB, 180 SB & 2408 SB Shredders

(Starting w/Serial No. 47010)

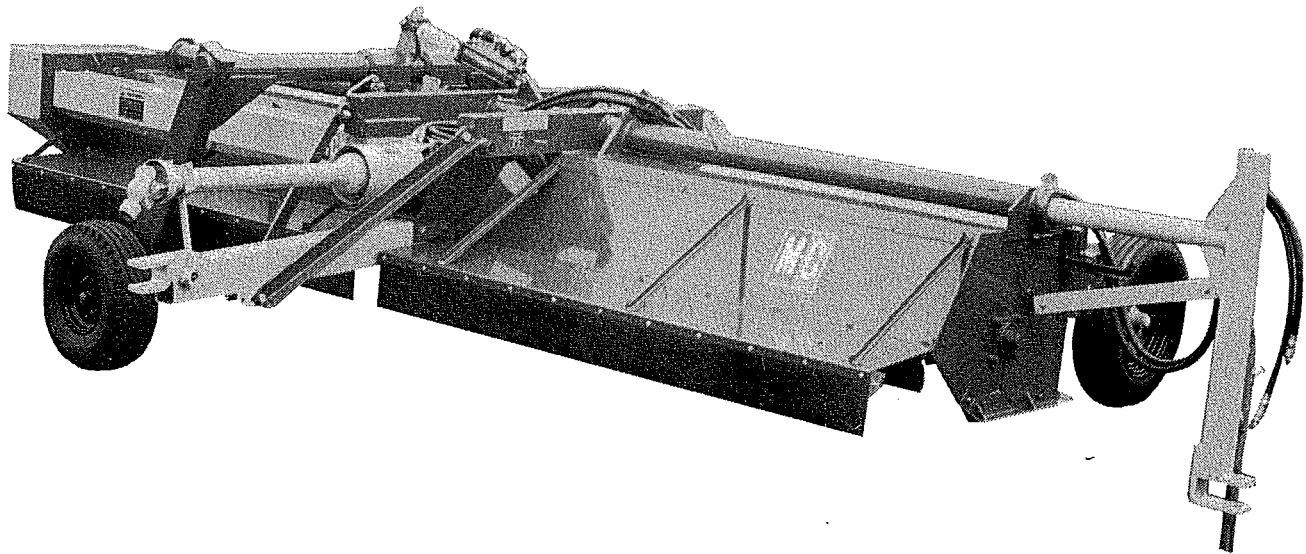

Model 180 SB With Optional End Tow System

OPERATOR'S MANUAL

Form No. SH-201, October 1985

B.C. Mathews Co./

500 Industrial Ave., Crystal Lake, IL 60014, U.S.A.
815/459-2210 Telex 72-2488

CONTENTS

	Page
Introduction	
To The Owner	3
Work Safely	3
Warranty Registration	3
Model and Serial Number Location	3
Parts Ordering Instructions	3
Capscrew Grade Identification	4
Metric (SI) Measurement Conversion Table	4
Set-Up Instructions	5
General	5
Cylinder Rear Mount	5
Wheel Mounts and Wheels	6
Pole and Supports	6
PTO Shaft	7
Stone Guards	7
Lubrication	7
Tractor Drawbar Adjustment	7
Operation	9
Safety Precautions	9
General	9
Tractor PTO and Ground Speed	9
Cutting Height	9
Cutter Bar	10
Transporting the Shredder	
Shredders Without Optional End Tow System	10
Shredders With Optional End Tow System	11
Pole Jack	14
Maintenance	14
Lubrication	16
Knife Sharpening	16
Knife Replacement	18
Drive Belt Adjustment	18
Drive Belt Replacement	19
Drive and Rotor Pulley Alignment	19
Idler Pulley Alignment	20
Drive and Rotor Pulley Replacement	20
Rotor Bearing Replacement	
Model 144 and 180 Left Bearing	21
Model 144 and 180 Right Bearing	22
Model 2408 Outer Bearing	23
Model 2408 Center Bearing	23
Output Shaft Outer Bearing Replacement	23
Output Shaft Center Bearing Replacement	24
Idler Pulley Bearing Replacement	26
Storing the Shredder	27
Pre-Season Check	27

Continued on next page

Parts	Page
Anti-Wrap	
144 & 180	29
2408	35
Axle	
144 & 180	29
2408	33
Axle Wheel Mount and Hub Assembly	47
Belts	37
Belt Idler	45
Belt Idler Push Rod and Spring	44
Body	
144 & 180	28
2408	32
Cutter Bar	
144 & 180	31
2408	35
Drive Line	36
End Tow System (Optional)	48
Gear Box	
144 & 180	42
2408	43
Guards (Drive Line)	36
Guards (Stone)	
144 & 180	31
2408	35
Knives	40 & 41
Knife Kits	44
Output Shaft	39
Output Shaft Bearings	37
Output Shaft Universal Joint	47
Pole	
144 & 180	31
2408	35
Power Take-Off Shaft	46
Pulleys and Bushings (Drive and Rotor)	37
Rotor Assembly	40 & 41
Rotor Bearings	
144 & 180	29
2408	33
Skids	
144 & 180	31
2408	33
Transport Lock	
144 & 180	29
2408	33

INTRODUCTION

To The Owner

Before operating your Shredder read the Operating, Adjustment and Maintenance instructions in this manual. Check each item referred to and become familiar with the adjustments and/or settings required to obtain efficient operation and maximum trouble free service.

Work Safely



This symbol is used to call your attention to instructions concerning your personal safety. Be sure to observe and follow these instructions.

Warranty Registration

It is important to send in your warranty registration card as soon as your new Shredder is delivered. Not only does the card validate your Shredder warranty, but it is also our way of knowing who has purchased M-C equipment so that we can keep in touch with you.

Model and Serial Number Location

The model and serial number of your Shredder is stamped on a plate located on the left side of the body, see Figure 1. For future reference, record the model and serial number in the blank spaces in Figure 2.

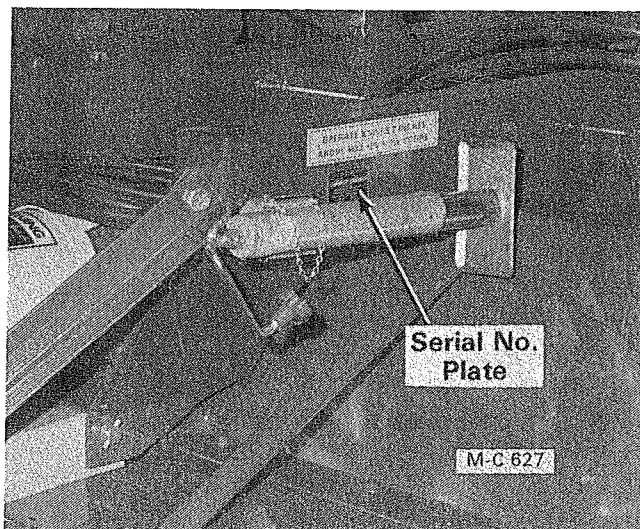
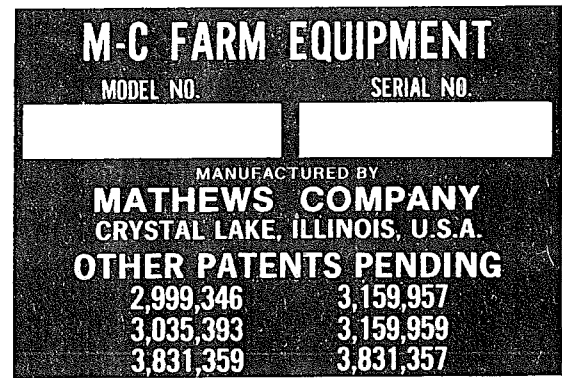

Figure 1



M-C 011

Figure 2

Parts Ordering Instructions





1. Order parts from your local M-C dealer or distributor.
2. Always furnish the Shredder model and serial number. This information is stamped on the serial number plate.
3. Service parts for your Shredder are listed in the "Parts" section of this manual. When ordering parts be sure to furnish the part number, description and quantity required.
4. Inspect all shipments upon receipt. If any packages and/or boxes are missing, or parts are damaged, file a claim with the carrier immediately. Failure to do so may void a claim. Check the shipment against the packing list carefully. Report any shortages to the shipper immediately.
5. Do not return any parts to the B.C. Mathews Co. without a "Return Goods Authorization" from the factory. All return parts shipments must be shipped prepaid (COD shipments will not be accepted). Shipments must also include the following:
 - A. A letter of explanation including the "Return Goods Authorization Number," your name and address.
 - B. A list of all parts being returned. List must include part numbers, description, quantity and original invoice number.

Capscrew Grade Identification

There are four grades of hex-head capscrews. Grade 1 and 2 are common capscrews, grade 5 and grade 8 are used when greater strength is required. Each grade can be identified by the marking on the head of the capscrew, see chart below.

When servicing the Shredder and/or replacing capscrews, be sure to use the correct size and grade. If in doubt, refer to the parts list. If a specific grade is not shown as part of the description, the capscrew is a grade 1 or 2.

CAPSCREW GRADE IDENTIFICATION CHART

S.A.E. Grade	Description	Capscrew Head Marking*
1	WILL HAVE A PLAIN HEAD - NO RADIAL LINES	
2	Low or Medium Carbon Steel Not Heat Treated	
5	WILL HAVE 3 RADIAL LINES Quenched and Tempered Medium Carbon Steel	
8	WILL HAVE 6 RADIAL LINES Quenched and Tempered Special Carbon or Alloy Steel	

*The center marking identifies the capscrew manufacturer.

Metric (SI) Measurements

(English Units & Metric (SI) Equivalents)

Area

1 square inch = 6.4516 square centimeters
 1 square foot = 0.0929 square meters
 1 square yard = 0.8361 square meters
 1 acre = 4047 square meters
 1 acre = 0.4047 hectare

Force

1 pound (force) = 4.45 newtons

Length

1 inch = 25.4 millimeters
 1 inch = 2.54 centimeters
 1 foot = 304.8 millimeters
 1 foot = 30.5 centimeters
 1 foot = 0.305 meters
 1 yard = 0.9144 meters
 1 mile = 1.6093 kilometers

Mass

1 ounce = 28.35 grams
 1 pound = 0.454 kilograms
 1 ton = 907.1848 kilograms

Power

1 horsepower = 0.7457 kilowatts

Pressure

1 psi = 6.89 kilopascals
 1 psi = 0.00689 megapascals
 1 inch of mercury = 3.377 kilopascals

Temperature

1 degree Fahrenheit ($^{\circ}\text{F} - 32$) \div 1.8 = $^{\circ}\text{Celsius}$

Torque

1 inch pound = 0.113 newton meters
 1 foot pound = 1.356 newton meters

Velocity

1 mile per hour = 1.61 kilometers per hour

Volume

1 bushel = 35.24 liters
 1 bushel = 0.0352 cubic meters
 1 pint = 0.4731 liters
 1 quart = 0.9464 liters
 1 gallon = 3.7854 liters
 1 cubic inch = 16.387 cubic centimeters
 1 cubic foot = 0.0283 cubic meters
 1 cubic yard = 0.7646 cubic meters

NOTE: The B.C. Mathews Co. reserves the right to incorporate any changes in design without obligation to make these changes on units previously sold.

SET-UP INSTRUCTIONS

General

Before beginning to set-up your Shredder, read the set-up instructions carefully to become familiar with the machine.

Check to make sure that you have received all parts listed on your packing list and/or machine order. Make claims for any shortages immediately.

RIGHT or LEFT and FRONT or REAR of the Shredder is determined by standing behind the Shredder looking toward the tractor PTO.

Assemble the Shredder on a solid flat level surface to insure safety and to aid in aligning parts during assembly.



CAUTION: Get help if the parts are too heavy or difficult for you to handle.



CAUTION: Always use safety stands or blocking in conjunction with hydraulic jacks or hoists. Do not rely on the jack or hoist to carry the load, they could fail.

IMPORTANT: Never lift or handle the Shredder by the rotor. Also, when shipping, never use the rotor as an anchor point to tie the Shredder down.

Cylinder Rear Mount

1. The cylinder rear mount with floating link is installed on the left side of the rear axle at the factory. Install the optional mechanical ram or customer supplied hydraulic ram between the cylinder front mount and the cylinder rear mount floating link, see Figure 3.

Wheel Mounts and Wheels

1. Install the wheels and tires on the wheel mounts. Inflate the tires to 32 lbs. Attach a sling to the lifting eyes on the top of the Shredder body. Lift the Shredder with a chain hoist just high enough to install the wheel mounts and wheels.

IMPORTANT: Do not lift the Shredder by the rotor.

2. Determine wheel spacing on the Shredder axle needed to track correctly in your crop rows. The wheel spacing on the left and right should be the same distance from the center of the Shredder for proper balance.

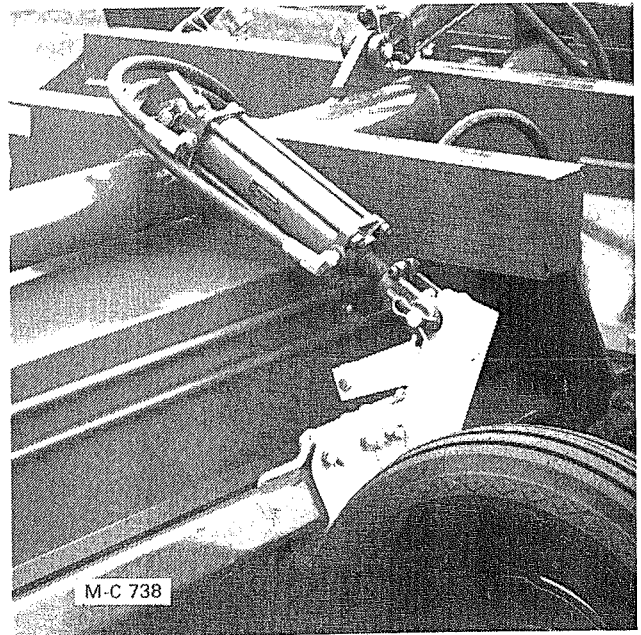

Figure 3 - 180 With Optional End Tow System

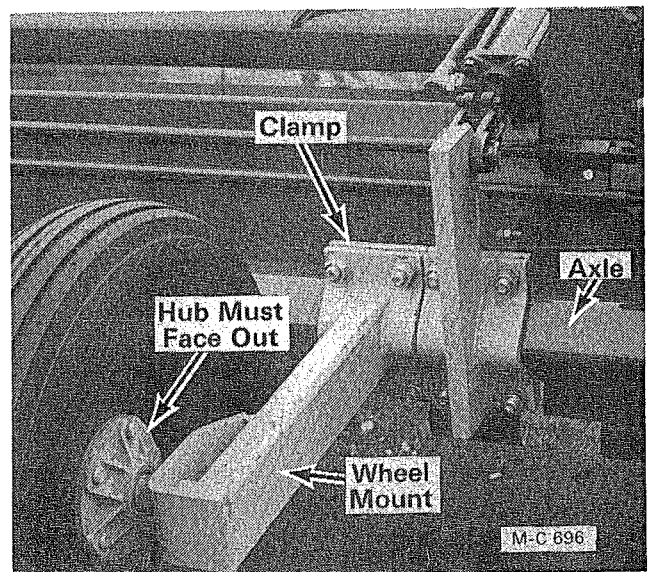

Figure 4

3. Install the wheel mounts and wheels on the axle at the desired spacing (see note). Right and left axle hubs must face out, see Figure 4. Secure each wheel mount clamp with four $\frac{3}{4}$ "-10 x $2\frac{1}{2}$ " (Grade 5) hex-head capscrews, lockwashers and nuts.

NOTE: If necessary, the optional mechanical or hydraulic ram can be used to rotate the axle to obtain wheel mount clamp alignment.

4. Lower the Shredder and check to see that all wheels contact the ground. If they do not, reposition the wheel mount(s) on the axle.

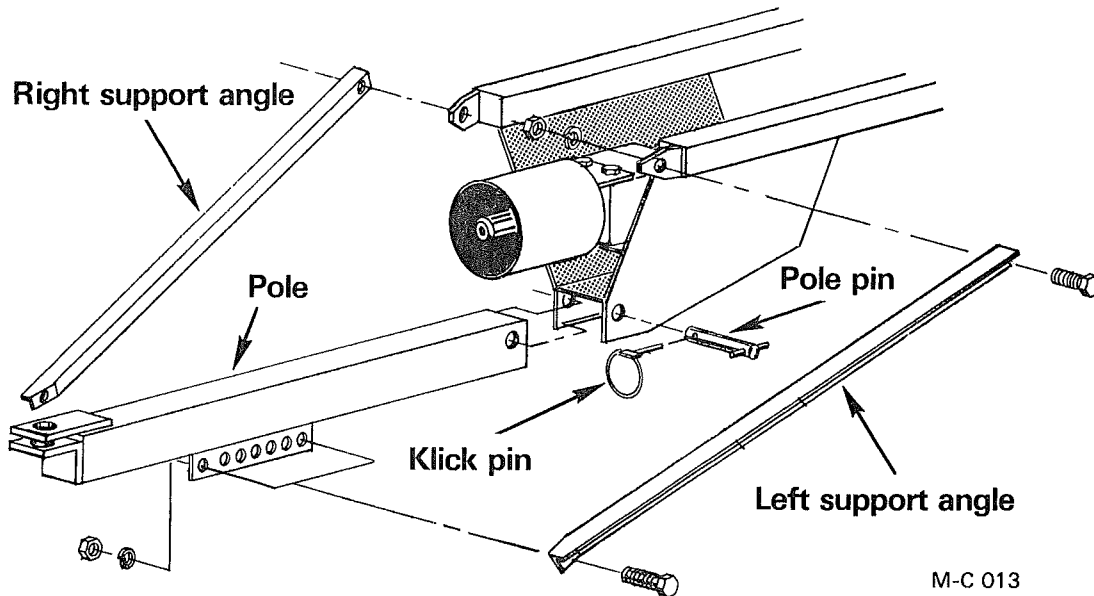

Figure 5

M-C 013

Pole and Supports

1. Lift the front of the Shredder with a chain hoist and place the pole in position under the gear box and install the pole pin, see Figure 5 and 6. Secure the pole pin with the kick pin. Be sure kick pin ring is snapped into the locking position.

IMPORTANT: Do not lift the Shredder by the rotor.

2. There are seven pole support angle mounting holes on each side of the pole, see Figure 5 and 6. Select the position that will set the pole at the correct tractor drawbar height and keep the Shredder body as level as possible (see note). Secure the pole support angles with four $\frac{3}{4}$ "-10 x 2" (Grade 5) hex-head capscrews, lockwashers and nuts.

NOTE: Keeping the Shredder body level as possible, front to rear, will insure safe operation and efficient shredding. The cutting height can be adjusted to suit various crops and/or field conditions. Refer to "Cutting Height" page 9.

3. Install the jack onto the mount and insert the retaining pin. Lower the jack to transfer the weight of the Shredder to the pole and body. Remove the chain hoist.

PTO Shaft

1. Remove the yellow PTO shaft guard from its shipping position on top of the gear box.

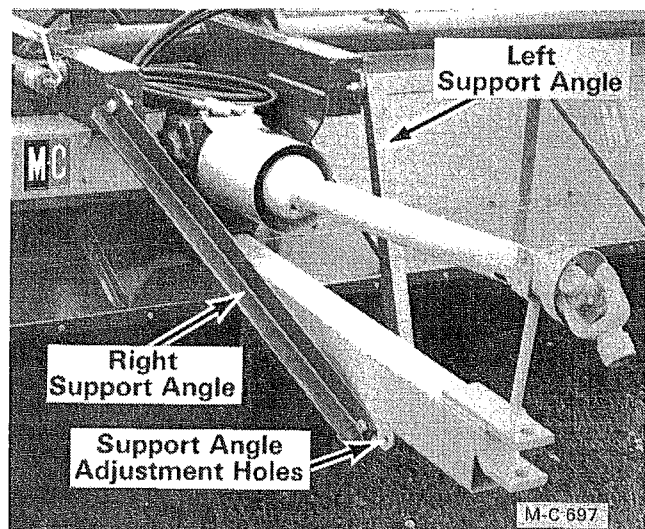
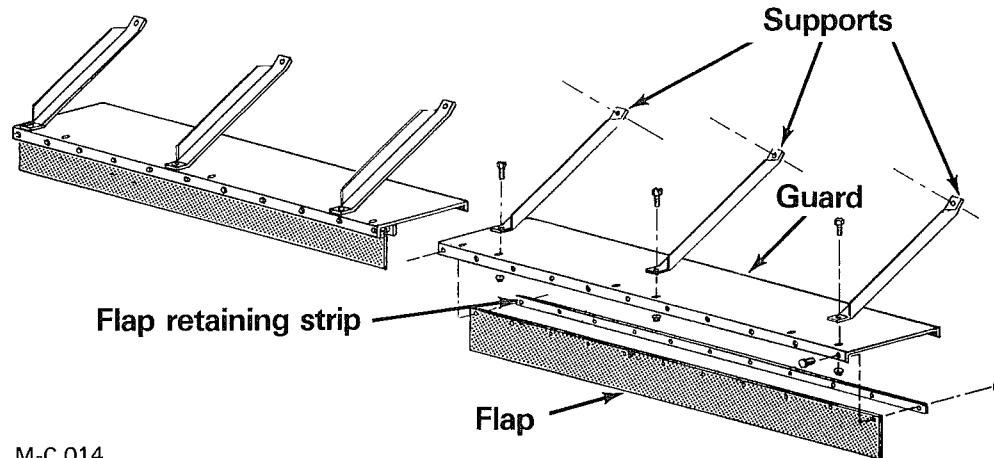

Figure 6

2. Remove any paint and foreign material from the gearbox splined input shaft and from both PTO shaft yokes. Be sure the quick disconnect devices on the PTO shaft couplings are working smoothly to ease installation.
3. Apply a small amount of grease to the splines of the gear box input shaft and both PTO shaft yokes.
4. Install the six spline yoke end of the PTO shaft onto the gear box input shaft. Be sure the Saf-T-Pin is fully engaged. Slide the PTO shaft guard over the PTO shaft and attach it to the two front mounting holes in the gear box with two $\frac{5}{8}$ "-11 X 1" (Grade 5) hex-head capscrews and lockwashers.



M-C 014

Figure 7

NOTE: The PTO shaft supplied with the Shredder has a $1\frac{3}{8}$ " - 21 spline yoke for the tractor and a six (6) spline end for the gear box. A $1\frac{3}{4}$ "-20 spline yoke is available for tractors with this size PTO drive. See Ref. 20 in PTO shaft parts list.

Stone Guards

1. Assemble the stone guard flaps and retaining strips to the stone guards as shown in Figure 7 and 8. Use $\frac{3}{8}$ "-16 X 1" hex-head capscrews and locknuts.
2. Assemble the stone guard supports to the stone guards using $\frac{3}{8}$ "-16 X 1" (Grade 5) hex-head capscrews, flatwashers and locknuts. The flatwashers go under the locknuts.
3. Remove capscrews and locknuts securing the front cover to the Shredder body at the locations shown in Figure 9 page 8. These are the locations that the stone guard supports bolt to.
4. Install the assembled stone guards to the Shredder front cover, see Figure 10 page 8. Use $\frac{3}{8}$ "-16 X 1" (Grade 5) hex-head capscrews, flatwashers and locknuts to secure the stone guard supports to the Shredder front cover. The flatwashers go under the locknuts. Use $\frac{3}{8}$ "-16 X $\frac{3}{4}$ " (Grade 5) hex-head capscrews and locknuts to secure the stone guards to the Shredder front cover.

Lubrication

1. Remove the oil level plug on the left side of the gear box, see Figure 11 page 8. The oil level should be even with the bottom of the

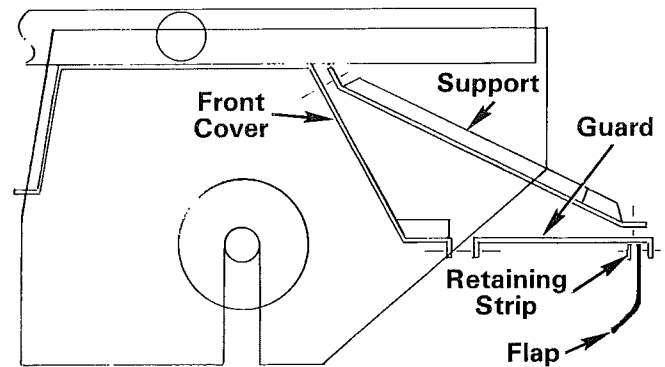

M-C 015

Figure 8

level plug. If the oil level is low, remove the bushing with vent on top of the gear box and add Mobilfluid 424 multipurpose transmission lubricant or equivalent until it just runs out of the level plug. Install the level plug. Check to be sure the vent is not plugged with paint or dirt. Install the bushing with vent.

2. Lubricate all lubrication fittings on the Shredder. For fitting locations refer to "Lubrication" page 14. Lubricate with a hand grease gun. Do not over lubricate. Too much grease may damage the bearing seals.

Tractor Drawbar Adjustment

1. To get the minimum amount of vibration and prolong the life of the bearings in the PTO shaft, adjust the tractor drawbar so that the distance from the end of the tractor PTO shaft to the center of the hole in the drawbar is 16 inches for the $1\frac{3}{8}$ " 21 spline PTO shaft and 20 inches for the $1\frac{3}{4}$ " 20 spline PTO shaft.

Remove capscrews (indicated by arrows) from the front cover on the right and left sides of the Shredder.

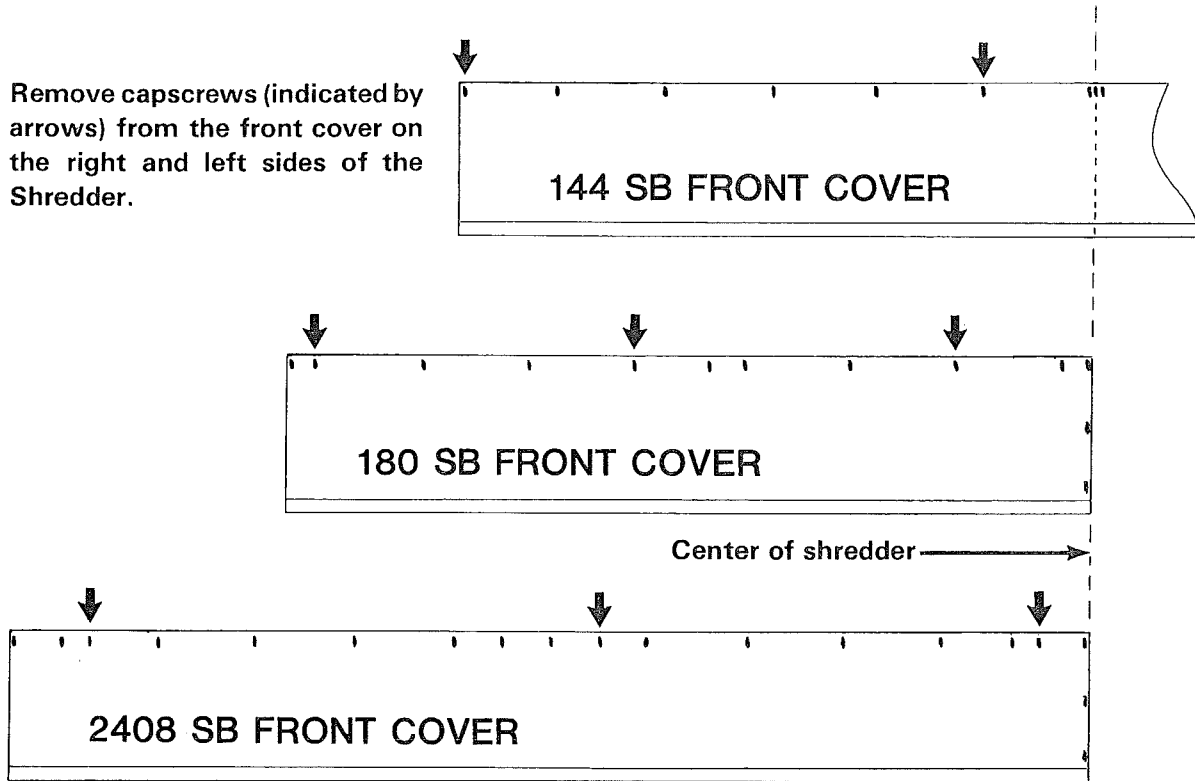

Figure 9

M-C 734

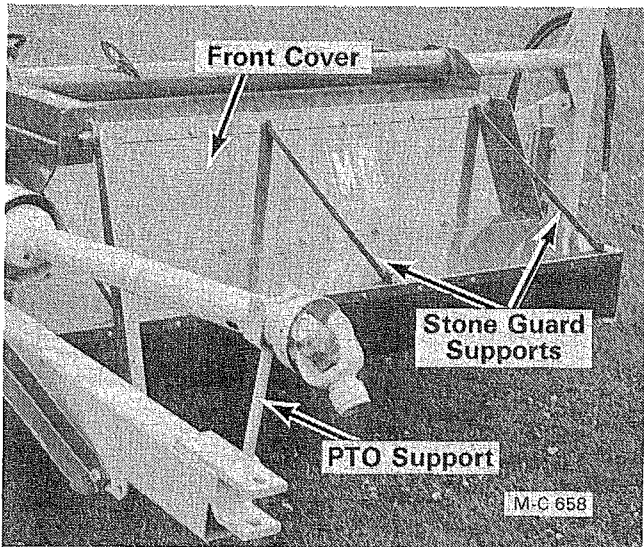

Figure 10

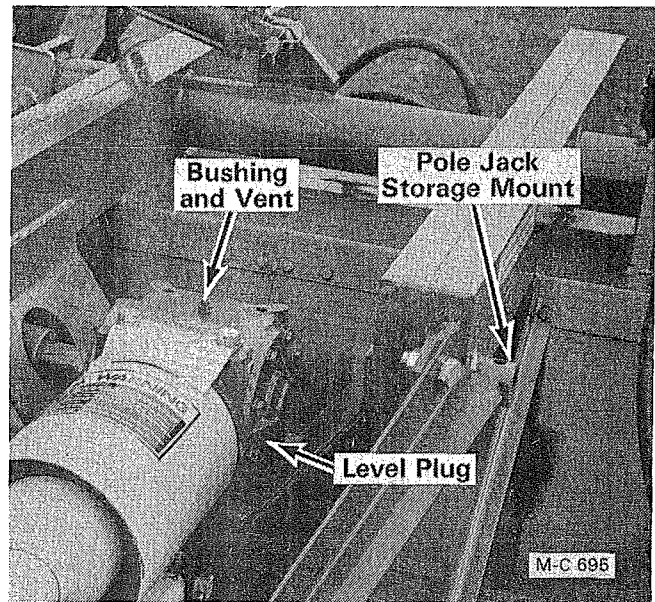

Figure 11 - Model 144 and 180 Shown

2. Connect the PTO shaft to the tractor PTO. Be sure the Saf-T-Pin or Safety Slide Lock is fully engaged.

IMPORTANT

NOW THAT YOUR SHREDDER IS SET UP AND ALL SAFETY EQUIPMENT IS INSTALLED, RUN IT AT A LOW RPM CHECKING TO MAKE SURE THAT ALL DRIVE LINE PARTS ARE MOVING FREELY.

OPERATION

Safety Precautions



A safe operator is the best insurance against accidents. The precautions listed below must be observed at all times.

- Do not allow anyone on or around the Shredder while it is operating.
- Do not operate the Shredder without all safety shields in place and secure.
- Do not operate the Shredder without the stone guard. Operating without the stone guard could cause personal injury.
- Do not make any inspections or adjustments while the Shredder is operating or while the tractor is running.
- On Tractors not equipped with an over-running PTO clutch, the momentum of the Shredder rotor may propell the tractor forward when the tractor clutch is disengaged.

General

1. It takes approximately 10 to 15 acres of shredding to get the inside of the Shredder and knives polished to obtain the best performance. As the Shredder breaks in, performance will improve.
2. Always start and stop the Shredder slowly to prevent excessive shock loads to the belt drive assembly and rotor. Engage and disengage the tractor PTO at low engine RPM.
3. Rotor rotation is counterclockwise when standing on the right side of the Shredder looking at the belt guard cover.
4. Never operate the Shredder with missing or broken knives. If any knives are missing or broken, the rotor will be out of balance and the Shredder will vibrate. Replace missing or broken knives in sets. See "Knife Replacement" page 16 for procedure.



CAUTION: Before attempting to make any inspection, be sure to disengage the PTO and stop the tractor engine.

5. After 10 to 20 hours of operation check the drive belt adjustment, see page 18.

6. A safety check should be made after the Shredder has been in operation a few hours.
 - A. Tighten all capscrews and locknuts.
 - B. Inspect all knives and knife hangers to be sure they are not damaged and are secure.
 - C. Check to be sure that all guards and shields are in place and secure.
 - D. Inspect the wheel mounts, rotor, gear box, output drive shaft, belt drive assembly and PTO shaft for signs of unusual wear or lubrication leaks that could lead to part failure.

Tractor PTO and Ground Speed

1. The Shredder was designed to operate with a PTO speed of 1000 RPM. A ground speed of three (3) to (6) miles per hour can be used for shredding moderate to heavy crops.
2. Horsepower requirements will vary with the weight of the crop and/or the type of shredding being done. All of the Shredder drive components are rated safely to 100 horsepower capacity. Tractors with higher or lower horsepower ratings may be used.
3. A lower ground speed will decrease the power requirement by reducing the amount of material being shredded. A higher ground speed will increase power requirements.

Cutting Height

1. With different crops or field conditions it may be necessary to adjust the cutting height. The Shredder body can be raised or lowered easily and quickly to the desired cutting height by rotating the Shredder axle.

IMPORTANT: Operate with knives 2" above hill on row crops.

2. The Shredder axle can be rotated with the optional mechanical ram or an owner supplied hydraulic ram. The hydraulic ram is preferred. The operator can quickly raise and lower the Shredder body to avoid contacting the ground or other obstacles when shredding.
3. The Shredder body must be kept as level as possible from front to rear to insure safe operation and proper shredding action. The

Shredder can be leveled by moving the pole support angles forward or back in the pole mounting holes, see Figure 12. Seven (7) holes are provided for adjustment.

- Moving the angles forward will lower the cutting height and moving the angles to the rear will raise the cutting height. For best operation, the Shredder skids should be parallel to the ground. Be sure to tighten pole support angle capscrews after adjustment has been made.

Cutter Bar

- Two adjustable cutter bars are located under the front edge of the front cover. Shredders are shipped with the cutter bars in the fully retracted position. This position provides maximum clearance between the cutter bars and knives.



CAUTION: Disengage the PTO and stop the tractor engine before adjusting the cutter bars.

- If finer shredding is desired, loosen the capscrews and nuts securing the cutter bars to the front cover. Loosen the capscrews just enough to permit the cutter bars to move in the adjusting slots.
- Slide the cutter bars toward the back of the shredder until the desired spacing is obtained between the knives and the cutter bars. Adjust both sides evenly. Tighten capscrews and nuts.
- Before operating the Shredder, rotate the rotor **slowly** to be sure the knives do not strike the cutter bars.



CAUTION: When checking for clearance, do not stand behind the Shredder. Stay well clear and **listen** for possible interference.

Transporting the Shredder

Shredders Without Optional End Tow System

- The transport lock, Figure 13, holds the body of the Shredder up so that it can be transported with the hydraulic or mechanical ram disconnected.
- When the Shredder is to be transported, raise the body all the way up with the ram. Remove the pin from the storage bracket and

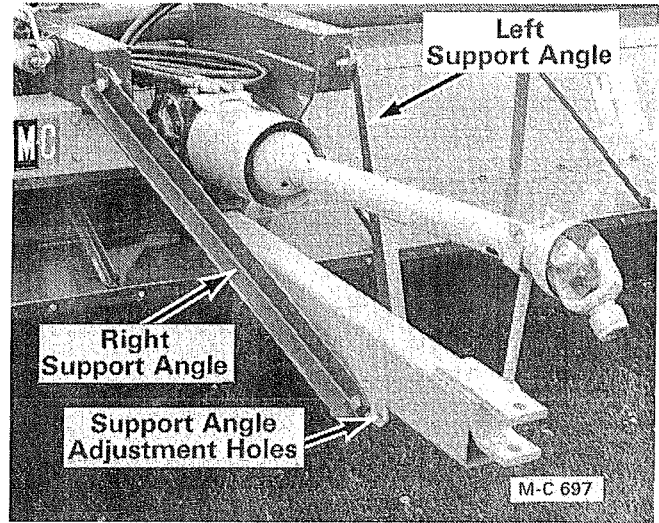

Figure 12

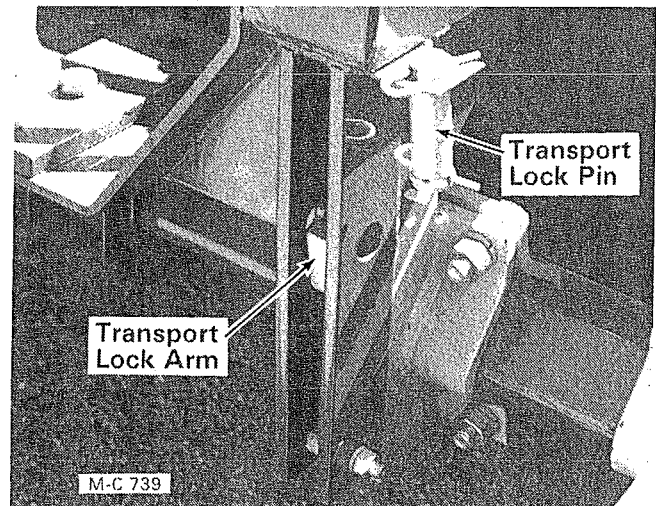

Figure 13

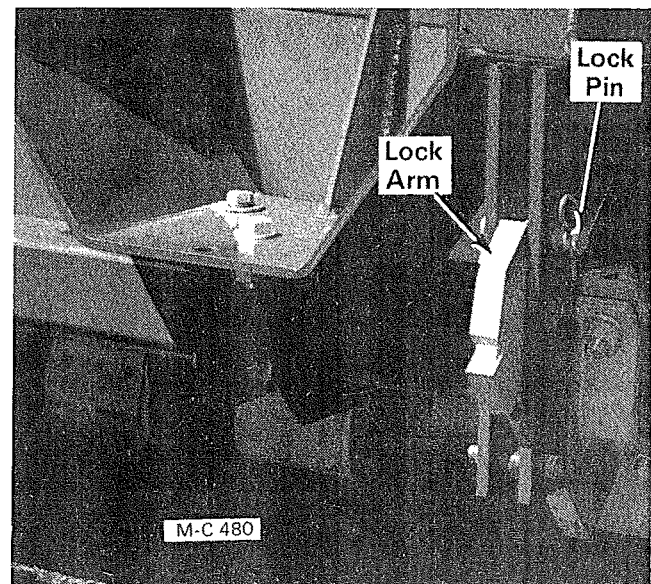

Figure 14

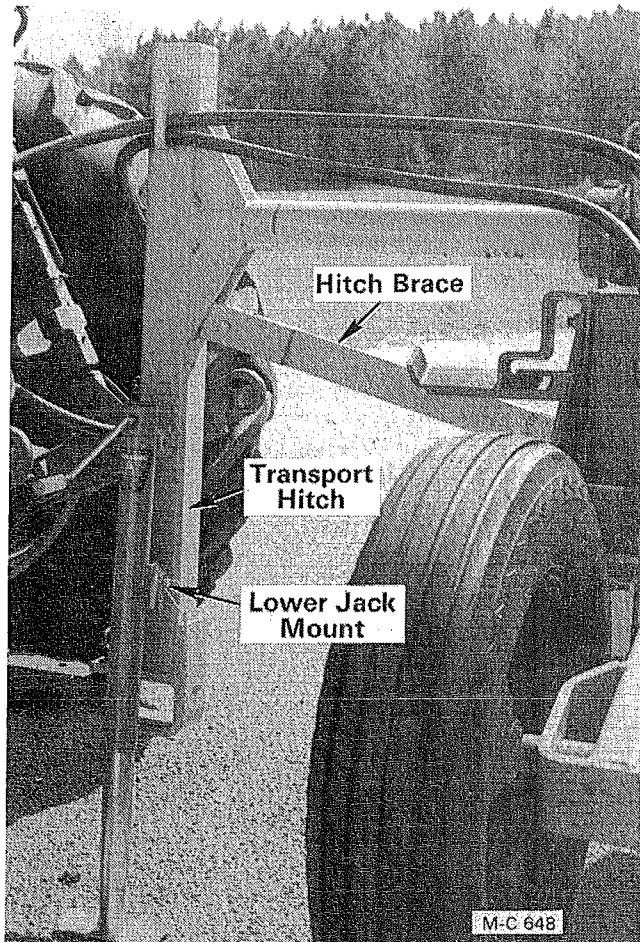

Figure 15

insert it through the body and over the transport lock arm as shown in Figure 14. Put the two pin clips on the pin and relieve the ram pressure.

Shredders With Optional End Tow System

Changing From Transport to Field Position

1. Stop the tractor engine and apply the parking brake.
2. Move the jack on the end transport hitch down to the lower jack mount. Lower the jack to the ground to take the weight off of the tractor drawbar, see Figure 15.
3. Remove the transport ram stop, see Figure 15A. Remove the PTO shaft support from the pole, put it on the mount on the left side of the Shredder and run the hydraulic hoses through it, see Figure 15B.
4. Remove the pole jack from the mount on the right side of the Shredder, put it on the pole and lower the jack to the ground, see Figure 15B. Start the tractor and lower the right

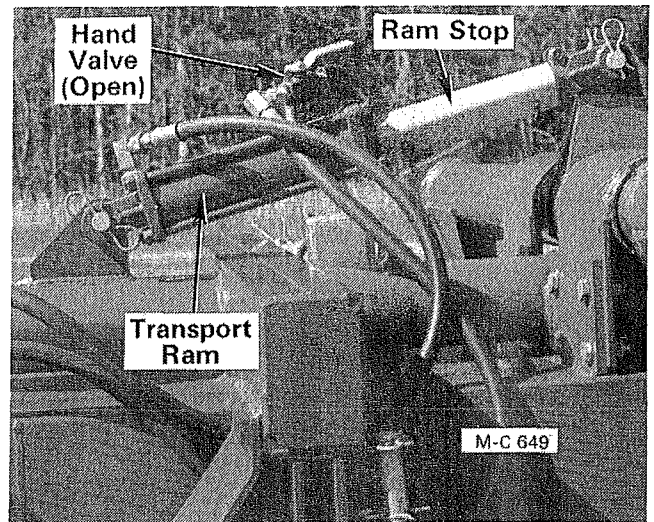

Figure 15A

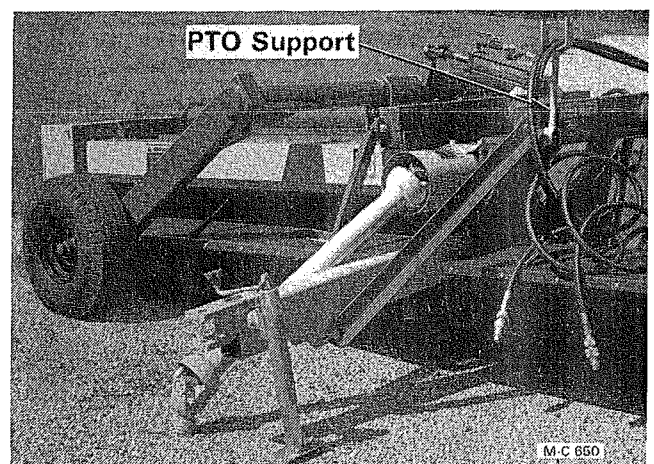

Figure 15B

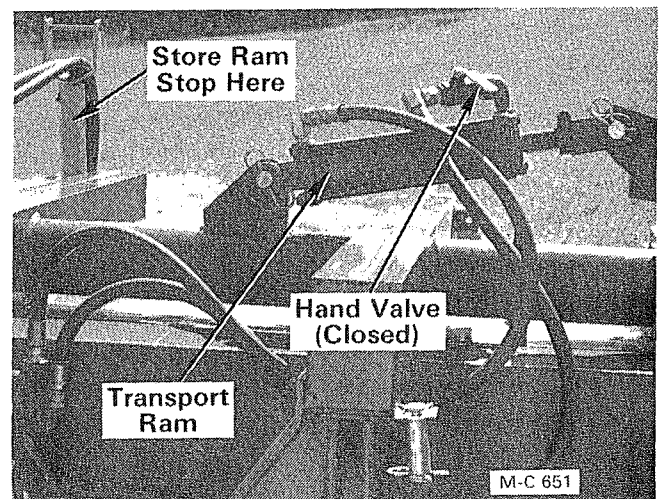

Figure 15C

side of the Shredder to the ground with the transport ram as shown in Figure 15B.

5. Raise the transport wheels all the way up with the transport ram and close the hand valve on the ram, see Figure 15C. Stop the

tractor engine. Store the transport ram stop on the PTO shaft support.



CAUTION: The transport ram hand valve must be closed to prevent the transport wheels from drifting down while shredding.

6. Disconnect the transport ram hydraulic hoses from the tractor and disconnect the tractor drawbar from the transport hitch.
7. Move the tractor to the Shredder pole and connect the drawbar to the pole. Stop the tractor engine and apply the parking brake.
8. Connect the Shredder hydraulic hoses to the tractor. Lower the transport hitch with the jack. Retract the jack all the way and move it to the upper mount on the transport hitch, see Figure 15D.
9. Remove the Shredder pole jack and store it on the jack mount on the right side of the Shredder. Remove the axle stop shear bolt, see Figure 15E. Raise the Shredder with the hydraulic ram or optional mechanical ram.
10. Disconnect the transport hitch brace from the Shredder. Remove the hair pin clip from the end of the transport hitch lock pin and pull the pin out, see Figure 15D. Store the lock pin in the holder on the left side of the Shredder, see Figure 15F.
11. Slide the transport hitch assembly into the pipe and place it on the storage bracket, see Figure 15F.

Changing From Field to Transport Position

1. Stop the tractor engine and apply the parking brake.
2. Remove the pole jack from the mount on the right side of the Shredder and put it on the pole. Lower the pole jack to the ground.
3. Pull the transport hitch assembly out and install the lock pin, see Figure 15G. Secure the lock pin with the hair pin clip. Connect the transport hitch brace to the Shredder.
4. Move the jack on the end transport hitch down to the lower jack mount, see Figure 15G.
5. Lower the Shredder with the hydraulic or optional mechanical ram just far enough to install the axle stop shear bolt, see Figure 15E. The shear bolt holds the Shredder axle and wheels up during transport.

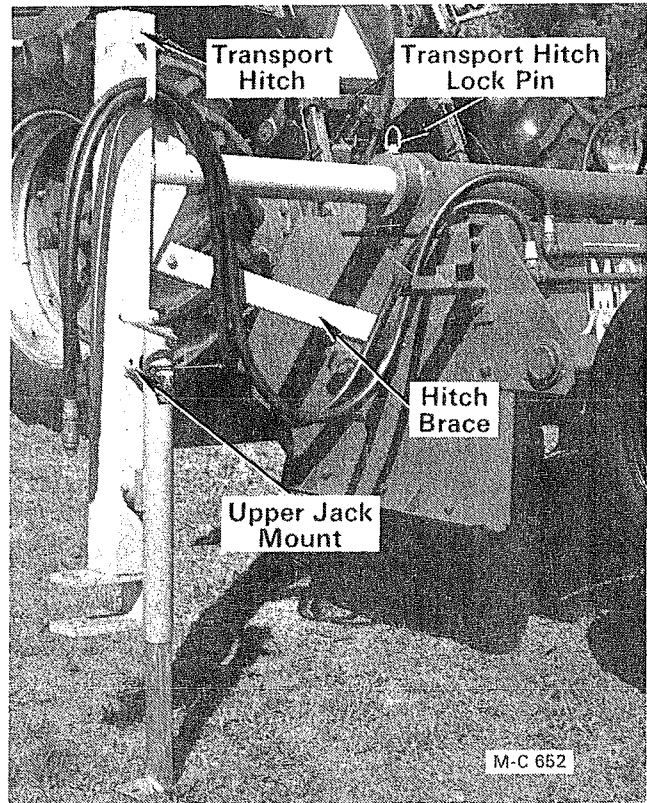

Figure 15D

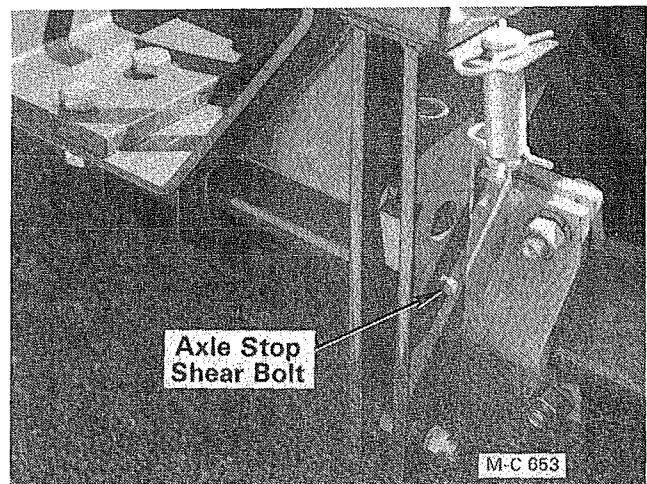

Figure 15E

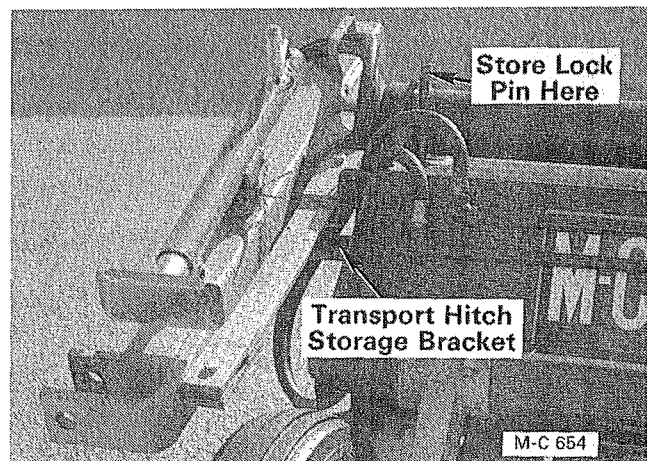

Figure 15F

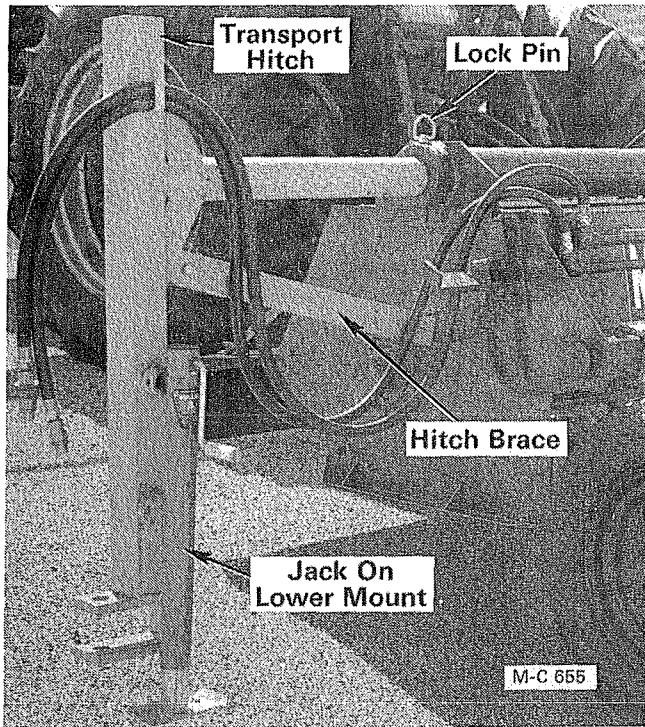

Figure 15G

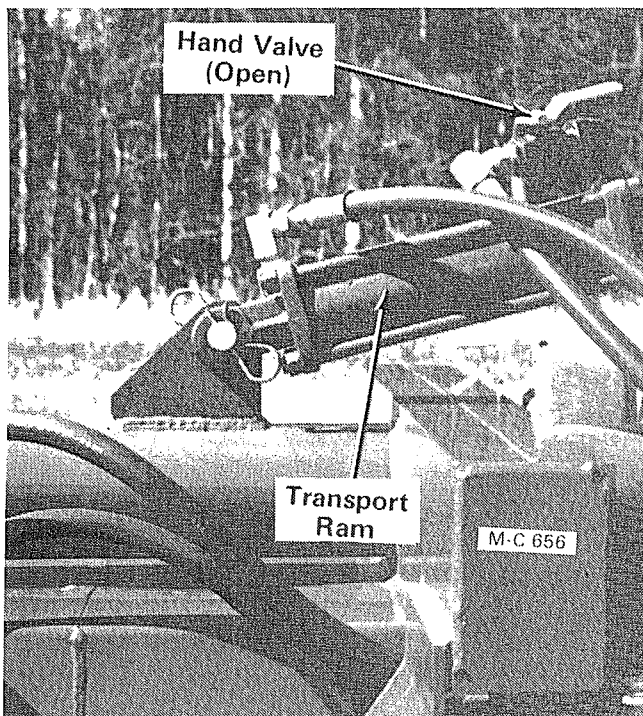

Figure 15H

6. Disconnect the Shredder hydraulic hoses and PTO shaft from the tractor. Disconnect the tractor drawbar from the Shredder pole.
7. Move the tractor to the transport hitch. Raise the transport hitch to the tractor drawbar height with the jack and connect the drawbar to the transport hitch, see Figure 15 page 11. Stop the tractor engine and apply the parking brake.

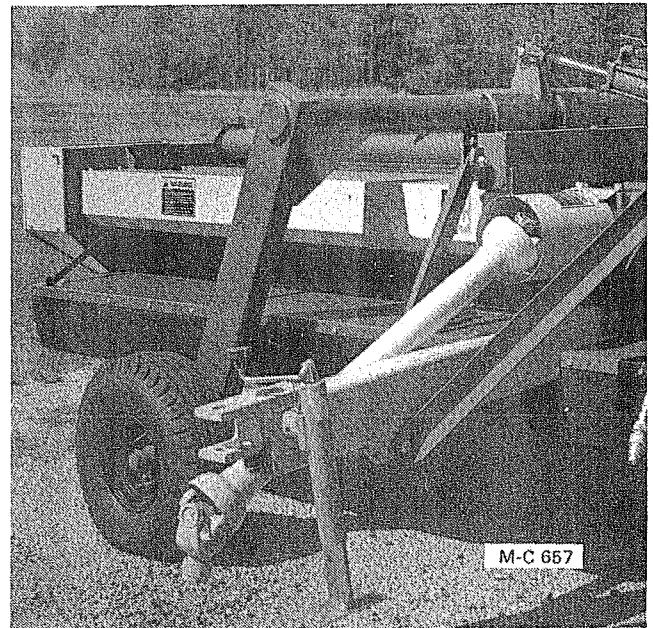

Figure 15J

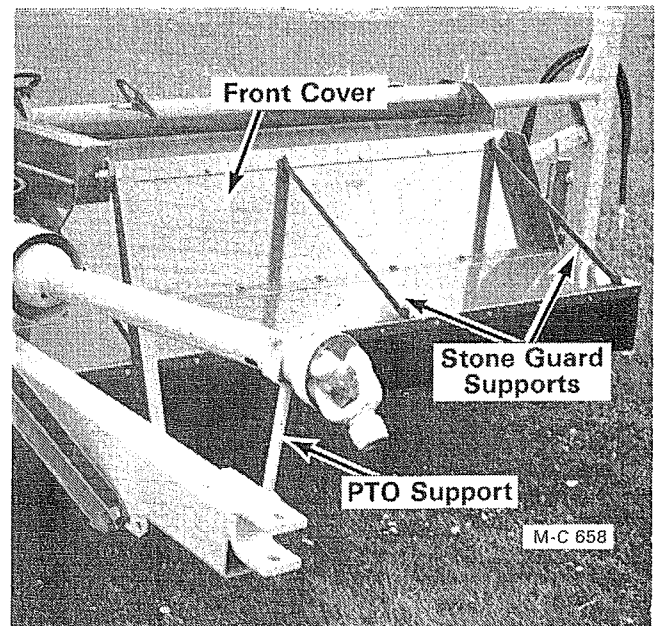

Figure 15K

8. Lower the transport hitch jack and move it to the upper jack mount.
9. Connect the transport ram hydraulic hose to the tractor. Open the hand valve on the transport ram, see Figure 15H.
10. Raise the Shredder to the transport position, see Figure 15J. Put the ram stop on the transport ram, see Figure 15A page 11.
11. Remove the pole jack and store it on the jack mount on the right side of the Shredder. Put the PTO support on the pole and place the PTO shaft on it, see Figure 15K.

Pole Jack

1. To prevent possible damage to tractor tires when making sharp left turns, remove the pole jack from the pole.

On Shredders without the optional end tow system, store it on the jack mount located on the left side of the body by the gear box. see Figure 16.

On Shredders with the optional end tow system, store it on the jack mount located on the right side of the body by the gear box.

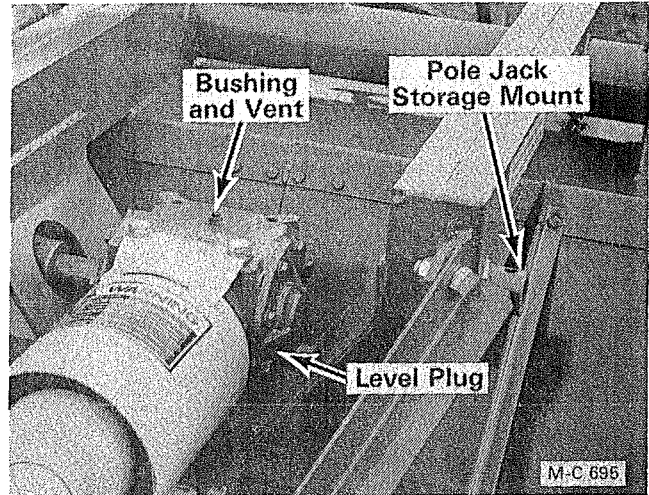

Figure 16

MAINTENANCE

Lubrication

Lubricate all fittings with a hand grease gun. Use a good grade of bearing grease. Do not over lubricate. Too much grease may damage the bearing seals.

Every 40 Hours

1. Power take-off shaft universal joints. One fitting in each yoke. One fitting in the telescoping spline shaft. See Figure 17.

NOTE: To locate the PTO spline shaft fitting, compress the PTO shaft until the distance from the center of one yoke to the center of the other is 40¼ inches. Rotate the male and female guards until the slots in the guards are aligned. Then rotate both guards together until the fitting appears in the slot.



Figure 17

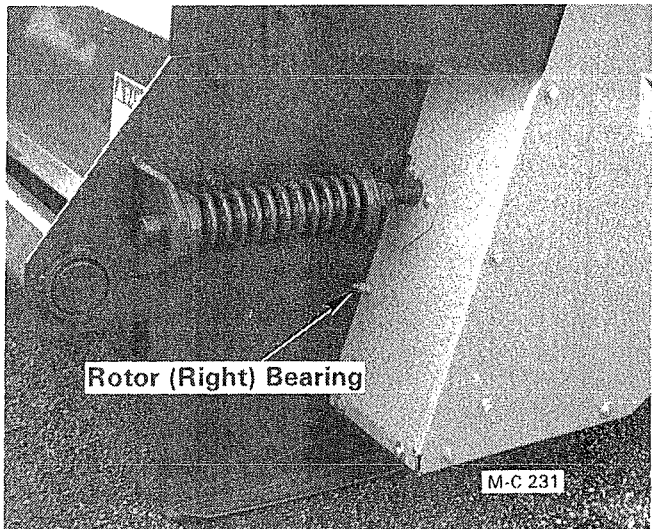

Figure 18 - Left Side Also on Model 2408

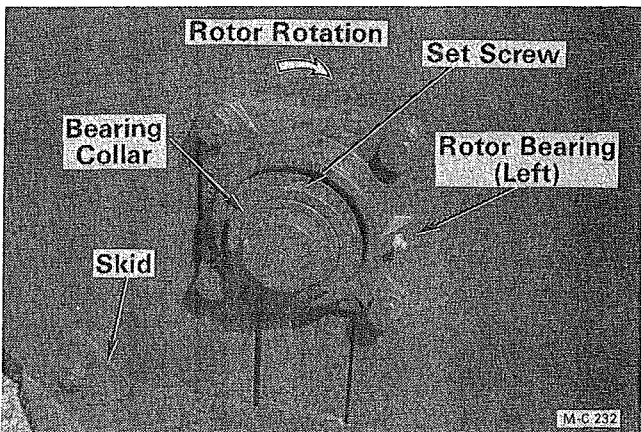

Figure 19 - Model 144 and 180

2. Rotor bearings. One fitting on each end of the rotor(s), see Figure 18, 19 and 20.
3. Output shaft bearings, see Figure 21 and 22.
4. Output shaft universal joint, see Figure 23, located under the output shaft guard.
5. Axle on optional end tow system, see Figure 23A.

Every 200 Hours (or seasonally)

1. Idler arm bushings. One fitting behind the belt guard cover, see Figure 24 (two on Model 2408).

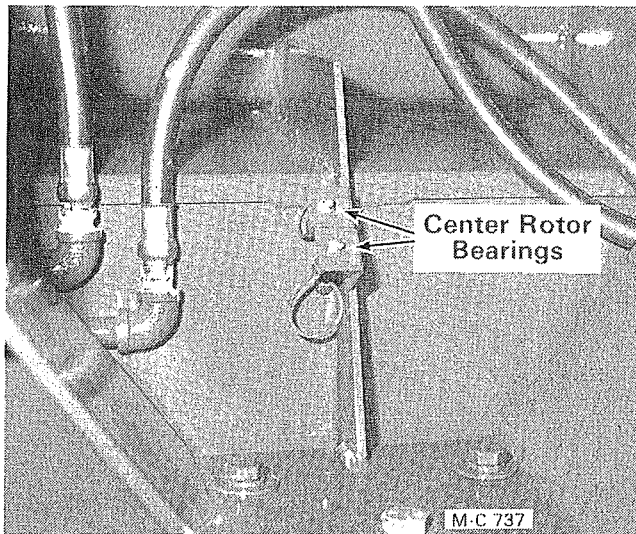

Figure 20 - Model 2408 Only

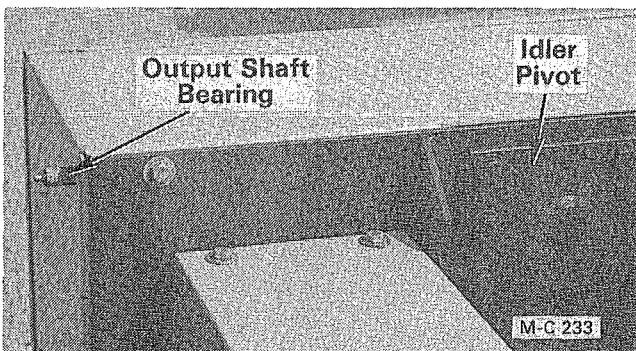

Figure 21 - Two on Model 2408

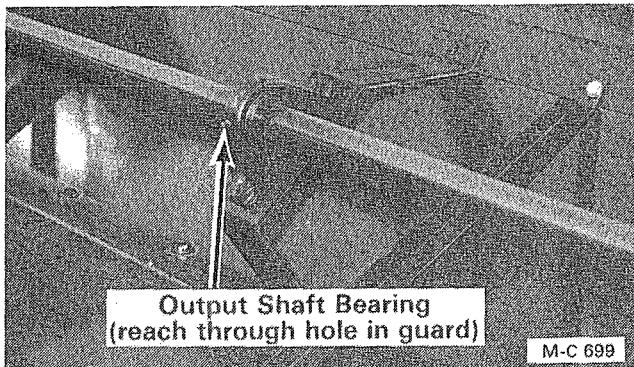

Figure 22 - Two on Model 2408

Periodically During the Season

1. Periodically check the oil level in the gear box. Remove the oil level plug on the left side of the gear box, see Figure 25. The oil level should be even with the bottom of the level plug hole. If not, remove the bushing and vent on the top of the gear box and add Mobilfluid 423 multipurpose transmission lubricant or equivalent until it just runs out of the level plug.
2. Install the level plug and the bushing with vent. Check to be sure the vent is open.

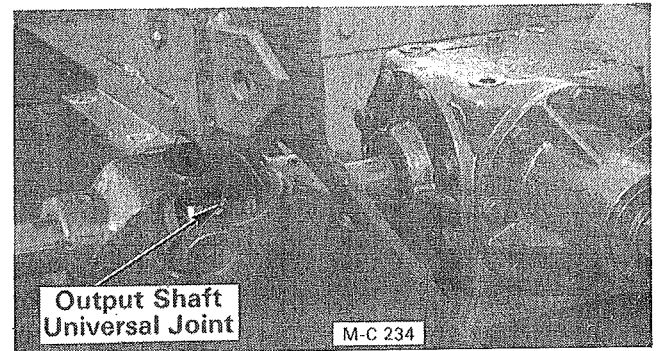

Figure 23 - Two on Model 2408

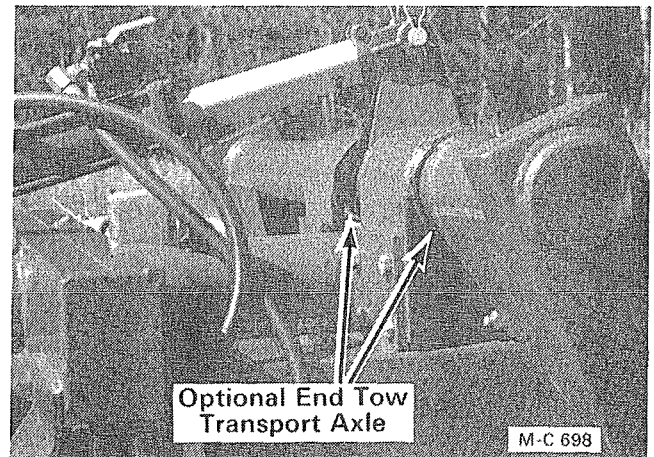

Figure 23A - Optional End Tow System

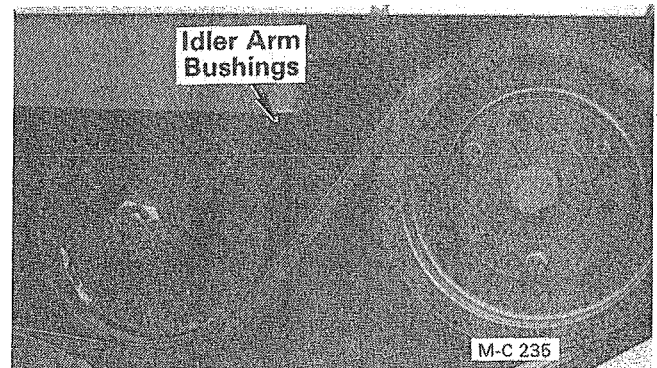

Figure 24 - Two on Model 2408

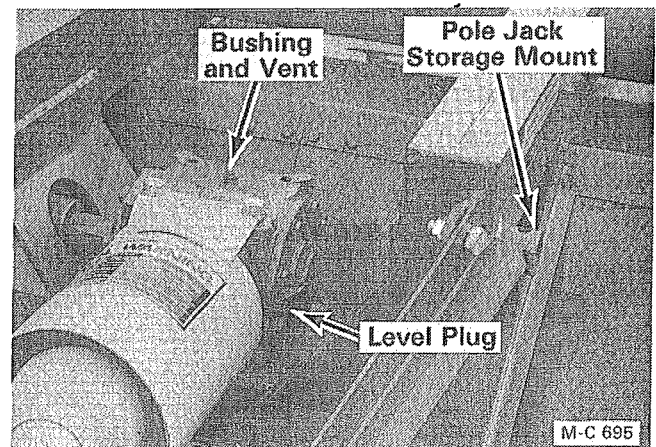

Figure 25

Knife Sharpening

1. Under normal operating conditions the knives will give you many trouble free acres of service with only occasional maintenance. The knives are mounted so they are free to swing on the rotor. This gives the knives increased cutting action and shock absorbing ability.
2. Normally it is not necessary to sharpen the knives unless the Shredder is being used to cut grass.
3. It is important to check the knives occasionally for sharpness and/or possible damage from hitting rocks or prolonged contact with the ground. Replace any damaged knives. Operating with damaged knives can cause vibration due to rotor imbalance.
4. The knives can be sharpened on the Shredder with a portable electric grinder or they can be removed (See "Knife Replacement" page 16) and sharpened on a bench grinder. The knives should be sharpened only on the back side. Be sure to retain the original 30° cutting angle.



CAUTION: Always wear safety glasses when sharpening knives with a grinder.

5. If the knives are to be sharpened on the Shredder, lift the back of the Shredder just high enough to provide access to the knives.



CAUTION: Always use safety stands or blocking in conjunction with hydraulic jacks or hoists. Do not rely on the jack or hoist to carry the load, they could fail.

IMPORTANT: Never lift or handle the Shredder by the rotor.

Knife Replacement

1. Lift the back of the Shredder just high enough to provide access to the knives.



CAUTION: Always use safety stands or blocking in conjunction with hydraulic jacks or hoists. Do not rely on the jack or hoist to carry the load, they could fail.

IMPORTANT: Never lift or handle the Shredder by the rotor.

2. Individual knives can be removed by removing the three carriage bolts and

locknuts securing the knife to the knife hanger, see Figure 26.

3. A complete set of knives and knife hangers on one rotor hanger bar can be removed as follows:

Model 144

NOTE: There is one hanger bar for each row of knives. An end locator bracket is welded to the left end of each hanger bar.

- A. Remove the left skid, see Figure 27.
- B. Turn the rotor and line up the hanger bar in the center of the slot in the left side of the body, see Figure 28. Block the rotor in this position.
- C. Loosen the four left rotor bearing mounting bolts and remove the lower half of the anti-wrap.
- D. Remove the two capscrews and locknuts securing the left end locator bracket to the rotor. Turn the locator bracket to a vertical position and pull the bracket and hanger bar out through the slot in the body. The knife hangers and knives will drop off as the hanger bar is pulled out.

Model 180

NOTE: There are two hanger bars for each row of knives. An end locator bracket is welded to the end of each left and right hanger bar.

- A. Remove the right and left skids, see Figure 27.
- B. Remove the rotor pulley. Refer to "Drive and Rotor Pulley Replacement" on page 20.
- C. Turn the rotor and line up the hanger bar in the center of the slot in the left and right side of the body, see Figure 28. Block the rotor in this position.
- D. Loosen the four left and right rotor bearing mounting bolts and remove the lower half of the anti-wrap on each side.
- E. Remove the two capscrews and locknuts securing the end locator bracket to the rotor. Turn the locator bracket to a vertical position and pull the bracket and hanger bar out through the slot in the body. The knife hangers and knives will drop off as the hanger bar is pulled out.

Model 2408

(S/N 47010 thru 47020)

NOTE: There is one hanger bar for each row of knives on each rotor.

- A. Remove the right and left skids and belt guard covers.
- B. Turn the rotor and line up the hanger bar in the center of the slot in the side of the body, see Figure 28. Block the rotor in this position.
- C. Remove the outer end locator bracket. Place a short $\frac{3}{8}$ inch bar in the hole in the center of the inner end locator bracket.
- D. Drive the hanger bar out as far as you can. Attach a vise grip plier to the hanger bar and pull the hanger bar out. The knife hangers and knives will drop off as the hanger bar is pulled out.

Model 2408

(S/N 47021 & Up)

- A. Remove the right and left skids and belt guard covers.
 - B. Remove the inner end locator bracket, see Figure 28. Turn the rotor and line up the hanger bar in the $1\frac{1}{4}$ inch hole in the front of the Shredder center plate. Block the rotor in this position.
 - C. Place a $\frac{3}{8}$ inch bar in the hole in the center of the outer end locator bracket. Drive the hanger bar out as far as you can.
 - D. Attach a vise grip plier to the hanger bar and pull the hanger bar out. The knife hangers and knives will drop off as the hanger bar is pulled out.
4. Installation of the knife hangers, knives and rotor hanger bars is the reverse of the removal procedure. When reassembling pay particular attention to the following:

- A. The dished or concave side of the knives must face the front of the Shredder when hanging down and swing freely.
- B. The end knives must be opposite each other at each end of the rotor. The wide end of the knife faces the outside, see Figure 28.

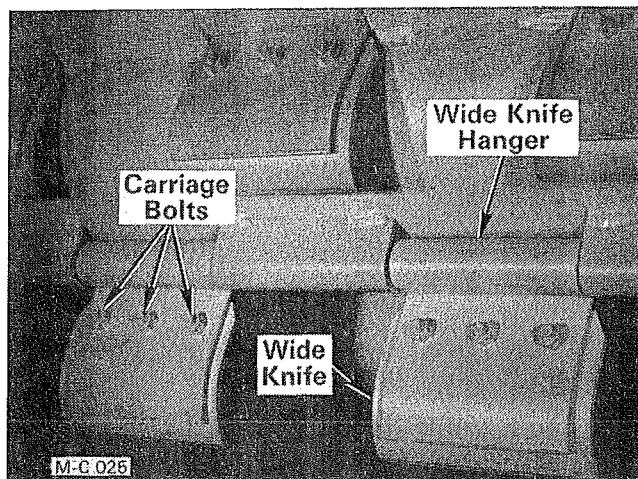

Figure 26

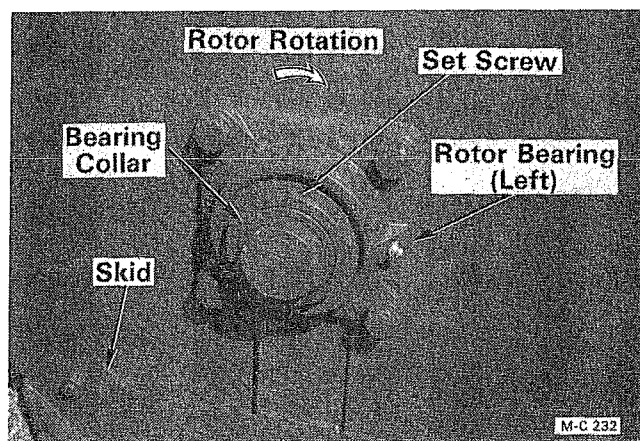

Figure 27

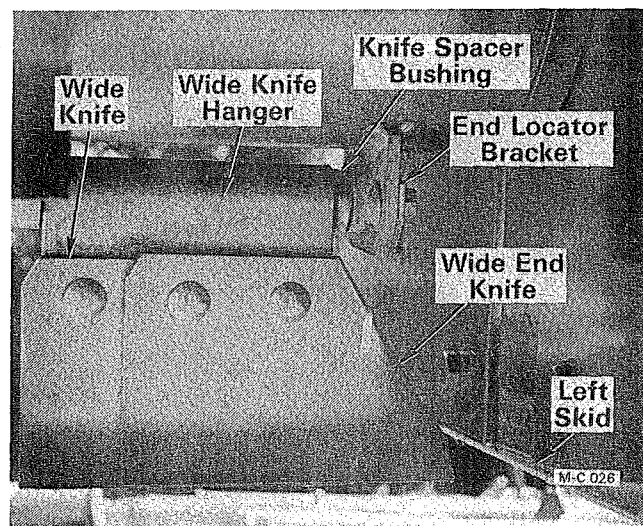

Figure 28

- C. A knife spacer bushing goes between each end locator bracket and wide knife hanger, see Figure 28.

IMPORTANT: Whenever a knife is replaced, always replace the knife on the opposite side to maintain rotor balance.

Drive Belt Adjustment

1. With the Shredder running, look at the idler push rod, Figure 29, to see if there is any back and forth movement. If there is, the belt tension needs to be adjusted.



CAUTION: Disengage the PTO and stop the tractor engine before adjusting the drive belt tension.

2. Loosen the jam nut and tighten the adjusting nut one full turn, see Figure 29.
3. Run the Shredder and check for idler push rod movement. If there is back and forth movement, stop the Shredder and tighten the adjusting nut one more full turn.
4. Continue this procedure until there is no back and forth movement of the idler push rod. Then tighten the adjusting nut one additional turn and tighten the jam nut.

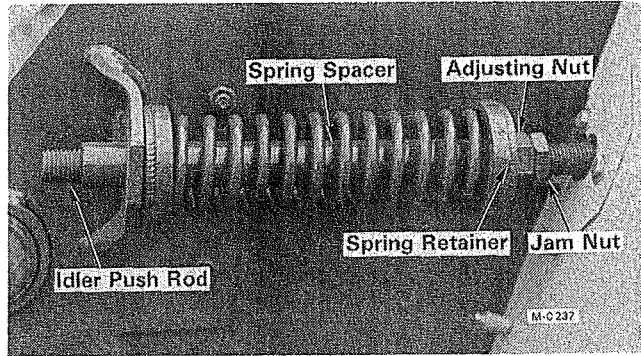

Figure 29

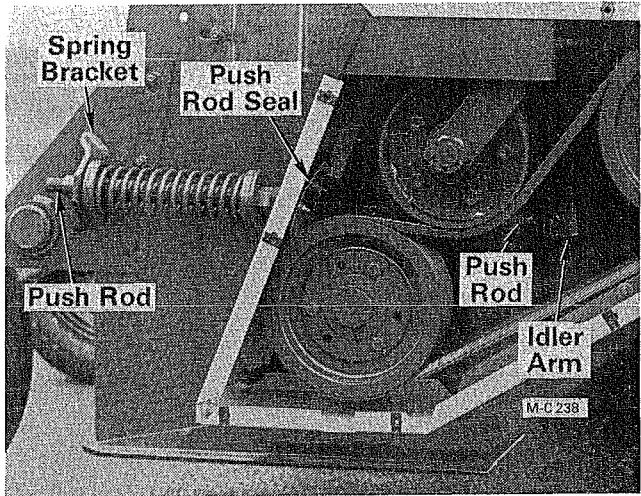

Figure 30

Drive Belt Replacement

IMPORTANT: The drive belts are a matched set. If just one belt failed, all belts must be replaced.

1. Remove the belt guard cover.
2. Before replacing the drive belts determine what caused the belts to fail. Three common causes of belt failure are:
 - A. If a belt is broken, this indicates a severe shock load or engagement of the tractor PTO at high engine RPM. Always engage and disengage the tractor PTO at low engine RPM.
 - B. If a belt is burned in places, this indicates that the belt is slipping. Adjust belt tension. Refer to "Drive Belt Adjustment."
 - C. If a belt has one segment turned over, is frayed or there is a great amount of powdered rubber in the belt guard, the drive and rotor pulleys are misaligned or the idler pulley is misaligned. Refer to "Drive and Rotor Pulley Alignment" following and "Idler Pulley Alignment" page 19.

To prevent another belt failure, correct the problem before installing new belts.

3. Loosen the idler spring jam nut and back off the adjusting nut to relieve all spring tension.

4. Remove the idler push rod seal, see Figure 30. Disconnect the idler push rod at the idler arm.
5. Pull the idler push rod out of the spring bracket and remove the idler push rod and spring assembly.
6. Block or tie the idler pulley up to the back of the belt guard and remove the old belts.
7. Before installing the new belts check Drive and Rotor Pulley Alignment following and the Idler Pulley Alignment page 19.
8. Clean dirt and debris from inside the guard and in the pulley grooves. Dirt build-up in the pulley grooves can ruin the belts.
9. Install the new drive belts. Install the idler push rod and spring assembly into the idler spring bracket, see Figure 30.
10. Connect the idler push rod to the idler arm and reinstall the idler push rod seal. Install the belt guard cover.
11. Turn the idler spring adjustment nut clockwise until the spring retainer is up to, but not tight against, the spring spacer, see Figure 29.

- Adjust the drive belt tension. Refer to "Drive Belt Adjustment" page 18.

Drive and Rotor Pulley Alignment

- Remove the belt guard cover and place a straight edge across the face of the drive and rotor pulley, see Figure 31.
- If the pulleys are not in alignment, loosen the idler spring jam nut and back off the adjusting nut to relieve all idler spring tension. Block the idler up toward the back of the belt guard.
- Remove the top belt and output shaft guards. Adjust the output shaft bearings, Figure 32, as follows:
 - Pulleys are out of alignment vertically** Raise or lower the output shaft and bearings as required by adding or removing shims under the bearings, see Figure 33.
 - Pulleys are out of alignment horizontally** Loosen the bearing mounting capscrews and move the output shaft and bearings forward or back as required. The bearing mounting holes are slotted for this purpose, see Figure 33.
- Install the output shaft guard. Check idler pulley alignment, see "Idler Pulley Alignment" following.

Idler Pulley Alignment

- The belt idler pulley must run in line with the drive and rotor pulleys so that the belts track flat on the idler pulley.

IMPORTANT: The drive and rotor pulleys must be in alignment before checking idler pulley alignment.

- To check idler pulley alignment, place a straight edge across the face of the idler pulley over to the drive pulley. Measure the distance from the face of the drive pulley to the straight edge at two places. If the measurements are equal the idler pulley is aligned.
- If the idler pulley is out of alignment, loosen the idler spring jam nut and back off the adjusting nut to relieve all idler spring tension, see Figure 29.

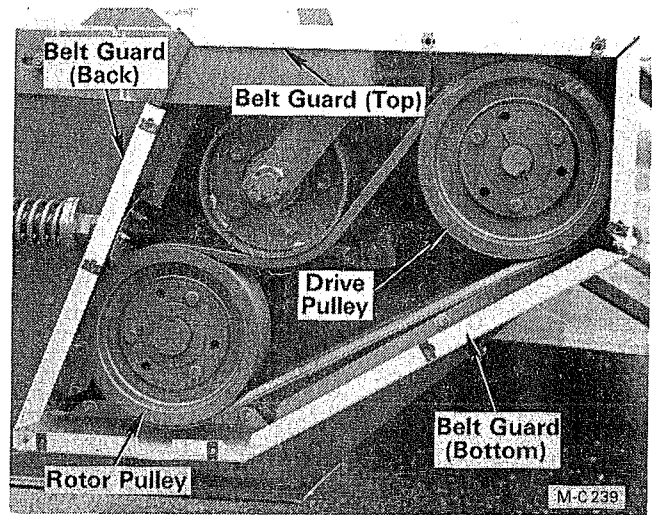

Figure 31

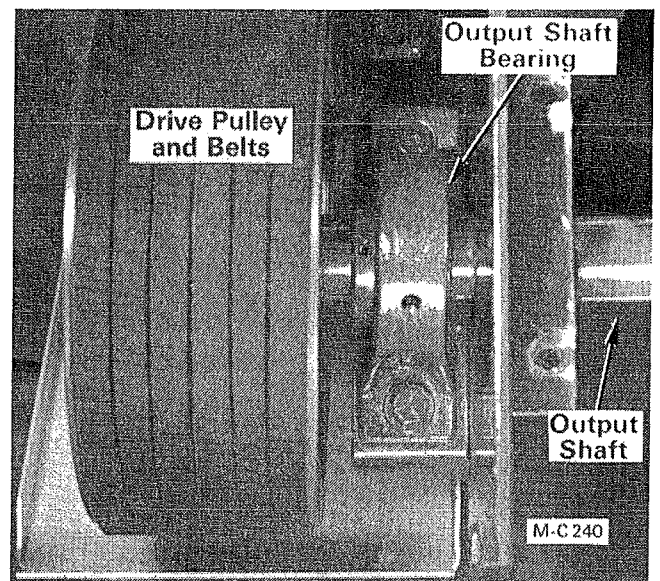

Figure 32

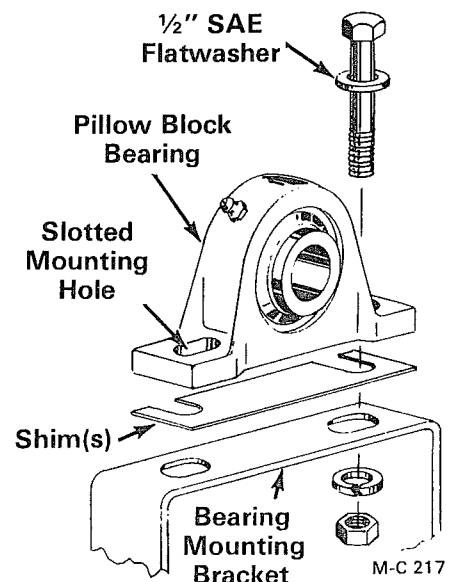

Figure 33

4. The idler pivot support is adjustable horizontally and the idler pivot is adjustable vertically, see Figure 34.
5. Loosen the idler pivot support capscrews, see Figure 35, and the idler pivot capscrews, see Figure 36.
6. Move the idler pivot support forward or back and/or the idler pivot up or down as required until the idler pulley is in alignment.
7. When the idler pulley is aligned with the rotor and drive pulley, tighten the idler pivot and pivot support capscrews securely.
8. Install the top belt guard and the belt guard cover.
9. Turn the idler spring adjustment nut clockwise until the spring retainer is up to, but not tight against, the spring spacer, see Figure 29 page 18.
10. Adjust the drive belt tension. Refer to "Drive Belt Adjustment" page 18.

Drive and Rotor Pulley Replacement

NOTE: The drive and rotor pulleys are held on the shafts with tapered bushings. The bushings have jack screw holes that are used to remove them. **Do not** attempt to remove the pulleys with a gear puller as this could result in damage to the pulleys.

1. Remove the belt guard cover, top belt guard and back belt guard.
2. Remove the drive belts. Refer to "Drive Belt Replacement" page 18 for procedure.
3. Remove the three mounting capscrews, see Figure 37. Thread the capscrews into the three jack screw holes in the pulley. Tighten the three capscrews progressively and evenly until the pulley is loose on the bushing.
4. Remove the pulley and bushing from the shaft. If the bushing does not slip off of the shaft, wedge a screwdriver blade in the saw cut in the end or flange of the bushing (not the tapered surface) to spread the bushing.
5. Before installing the bushing and pulley thoroughly inspect the tapered bore of the pulley and the tapered surface of the bushing. Any paint, dirt, oil or grease **must** be removed.

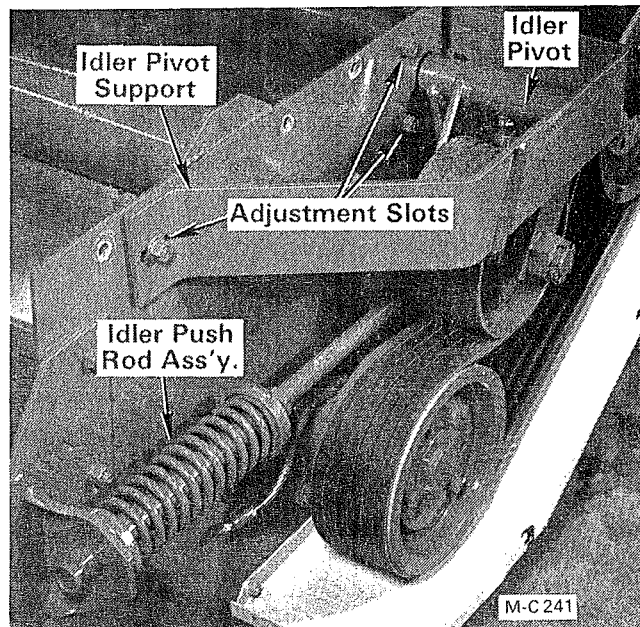

Figure 34

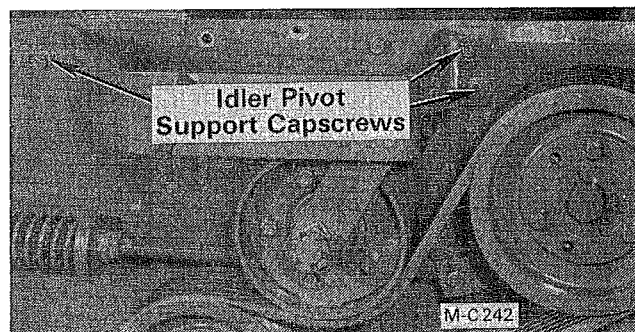

Figure 35

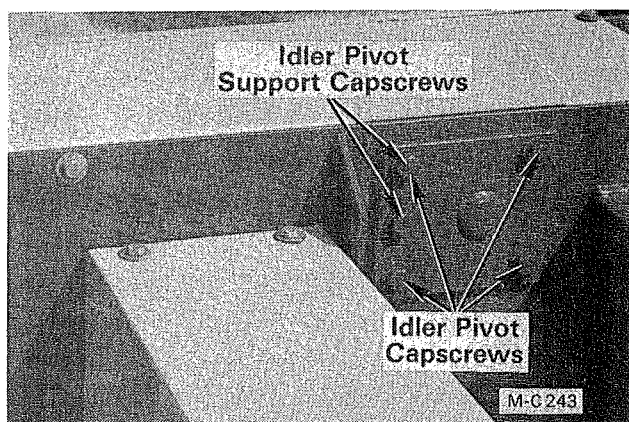

Figure 36

6. Place the bushing into the pulley from the back so that the bushing flange is to the inside, see Figure 38. The bushing and the bore of the pulley are tapered. Be sure to install the bushing into the large ID of the pulley tapered bore. If the bushing is installed into the small ID of the pulley, the pulley hub will crack when the mounting capscrews are tightened.

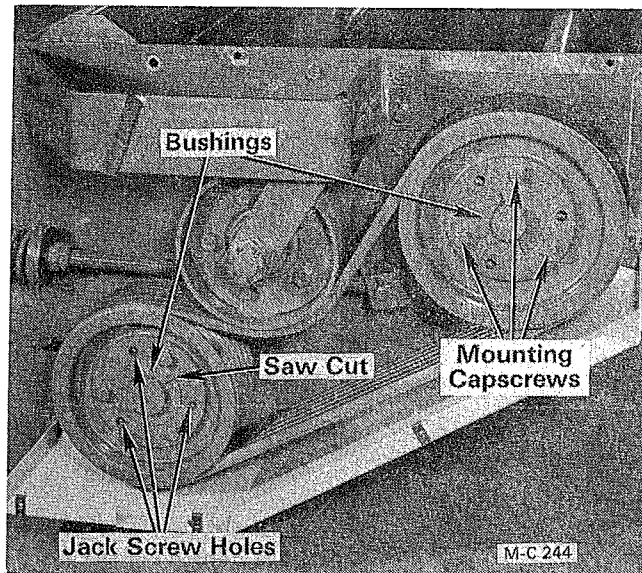

Figure 37

- Place the three capscrews through the open holes in the pulley and thread them into the bushing by hand. Do not tighten the capscrews.

IMPORTANT: The capscrew and bushing threads must be clean and dry. Do not lubricate.

- Install the key in the output drive and/or rotor shaft. Slide the bushing and pulley assembly onto the shaft. If the bushing is too tight on the shaft, wedge a screwdriver blade into the saw cut in the end of the bushing to spread the bushing.

- Install the belts and move the pulley and bushing in or out until the belts are in alignment on the pulleys. Tighten the three capscrews evenly and progressively. Torque the capscrews to 60 ft. lbs.

IMPORTANT: The tightening force on the three capscrews is multiplied many times by the wedging action of the bushing tapered surface. Do not exceed the specified torque, or use a lubricant on the capscrew threads. To do so may create bursting pressures in the hub of the pulley.

NOTE: There should be a $\frac{1}{8}$ to $\frac{1}{4}$ inch gap between the pulley hub and flange of the bushing. If the gap is closed, the shaft is undersize.

- Check "Drive and Rotor Pulley Alignment" page 19 and "Idler Pulley Alignment" page 19 and adjust if necessary. Install the back belt guard, top belt guard and belt guard cover.

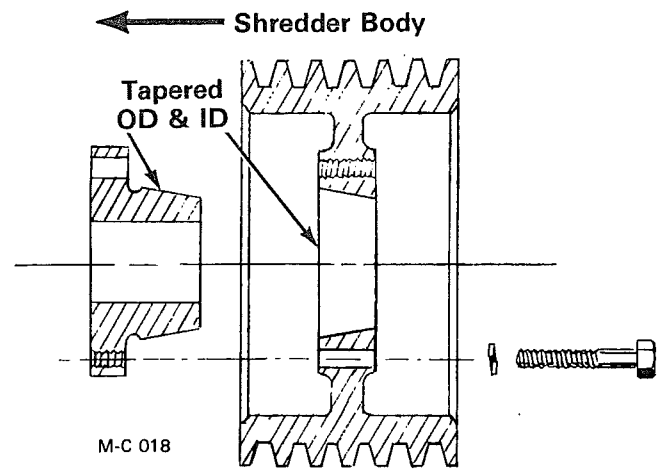

Figure 38

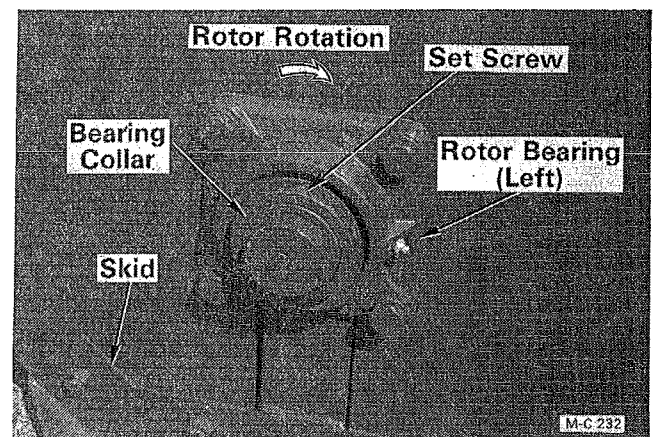

Figure 39

- Adjust the drive belt tension. Refer to "Drive Belt Adjustment" page 18.

Rotor Bearing Replacement

Model 144 and 180 Left Bearing

- Lift the left side of the Shredder and block up the rotor so it cannot fall when the bearing is removed. **Do not** lift the Shredder by the rotor.



CAUTION: Always use safety stands or blocking in conjunction with hydraulic jacks or hoists. Do not rely on the jack or hoist to carry the load, they could fail.

- Clean the end of the rotor shaft with emery cloth. Remove the two set screws in the bearing lock collar and four capscrews securing the bearing to the Shredder body, see Figure 39, and slide the bearing off of the rotor shaft.

3. Lightly polish the rotor shaft with emery cloth. Lubricate the rotor shaft with motor oil and slide the new bearing onto the shaft with the lubrication fitting facing to the rear.
4. Place the four mounting capscrews through the bearing and Shredder body. Refer to Figure 40. Partially thread the capscrews into the nut bars. Slide the two anti-wrap halves over the capscrews. Tighten the capscrews evenly to align the bearing on the shaft. Tighten the two set screws in the bearing lock collar.
5. Check the position of the two wipers (180° apart) at the end of the rotor, see Figure 41. They should be as close to the anti-wrap as possible without touching it. The wiper prevents material from building up on the anti-wrap. If necessary, loosen the wiper locknut and reposition the wiper in the adjusting slot.

6. Remove the safety stands or blocking and lower the Shredder to the ground. Lubricate the rotor bearing with a hand grease gun. Do not over lubricate. Too much grease may damage the bearing seal.

Model 144 & 180 Right Bearing

1. Lift the right side of the Shredder and block up the rotor so it cannot fall when the bearing is removed. **Do not** lift the Shredder by the rotor.

CAUTION: Always use safety stands or blocking in conjunction with hydraulic jacks or hoists. Do not rely on the jack or hoist to carry the load, they could fail.

2. Remove the belt guard cover, lubrication hose and back belt guard, see Figure 42. Remove the drive belts. Refer to "Drive Belt Replacement" page 18 for procedure.
3. Remove the rotor pulley. Refer to "Drive and Rotor Pulley Replacement" page 20 for procedure.
4. Clean the end of the rotor shaft with emery cloth. Remove the two set screws in the bearing lock collar and four capscrews securing the bearing to the shredder body and slide the bearing off of the rotor shaft.
5. Lightly polish the rotor shaft with emery cloth. Lubricate the rotor shaft with motor oil and slide the new bearing onto the shaft with

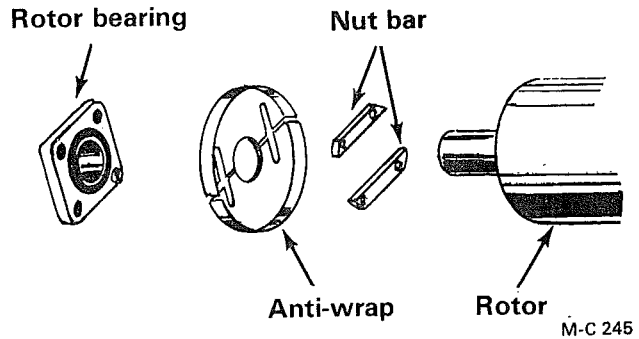

Figure 40

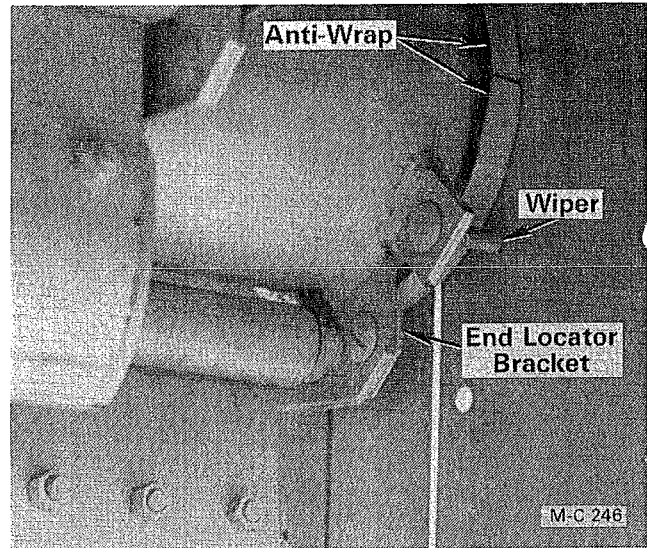

Figure 41

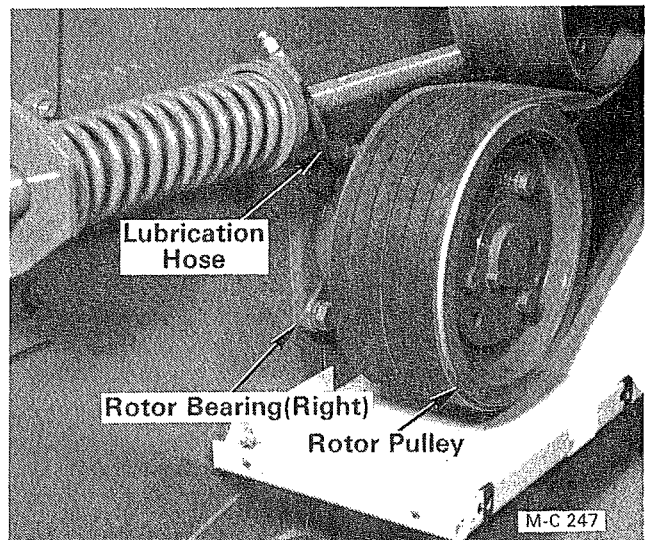

Figure 42

the lubrication fitting on top facing the rear of the Shredder.

6. Place the four mounting capscrews through the bearing and Shredder body. Refer to Figure 40. Partially thread the capscrews into the nut bars. Slide the two anti-wrap

halves over the capscrews. Tighten the capscrews evenly to align the bearing on the shaft. Tighten the two set screws in the bearing lock collar.

7. Check the position of the two wipers (180° apart) at the end of the rotor, see Figure 41. They should be as close to the anti-wrap as possible without touching it. The wiper prevents material from building up on the anti-wrap. If necessary, loosen the wiper locknut and reposition the wiper in the adjusting slot.
8. Install the rotor pulley. Refer to "Drive and Rotor Pulley Replacement" page 20 for procedure. Check "Drive and Rotor Pulley Alignment" page 19 and "Idle Pulley Alignment" page 19 and adjust if necessary.
9. Install the back belt guard, bearing lubrication hose and belt guard cover. Remove the safety stands or blocking and lower the Shredder to the ground.
10. Lubricate the rotor bearing with a hand grease gun. Do not over lubricate. Too much grease may damage the bearing seal.
11. Adjust the drive belt tension. Refer to "Drive Belt Adjustment" page 18.

Model 2408 Outer Bearings

1. The replacement procedure for the Model 2408 Outer Bearings is the same as the Model 144 and 180 Right Bearing on page 22.

Model 2408 Center Bearings

1. Support the rotor at each end with hydraulic jacks and safety stands or blocking.

 **CAUTION:** Always use safety stands or blocking in conjunction with hydraulic jacks. Do not rely on the jacks to carry the load, they could fail.

2. Remove the outer rotor bearing. Follow the procedure for the Model 144 and 180 Right Bearing on page 22. Remove the skid.
3. Remove the anti-wrap from the center rotor bearing center plate.
4. Disconnect the lubrication hose from the center bearing. Remove the four capscrews securing the center rotor bearing to the center plate.

5. Raise the rotor and remove the safety stands or blocking. Lower the rotor carefully until the center bearing clears the center plate.
6. Remove the two set screws in the bearing lock collar and slide the bearing off of the rotor shaft.
7. Lightly polish the rotor shaft with emery cloth. Lubricate the rotor shaft with motor oil and slide the new bearing onto the shaft with the lubrication fitting facing to the rear.
8. Raise the rotor into position with hydraulic jacks. Place safety stands or blocking under the rotor.

 **CAUTION:** Always use safety stands or blocking in conjunction with hydraulic jacks. Do not rely on the jacks to carry the load, they could fail.

9. Place the four bearing mounting capscrews through the bearing and the center plate. Tighten the capscrews evenly to align the bearing on the shaft. Tighten the two set screws in the bearing lock collar.
10. Install the anti-wrap. Connect the lubrication hose to the center bearing.
11. Install the outer rotor bearing. Follow the procedure for the Model 144 and 180 Right Bearing, page 22. Install the skid.

Output Shaft Outer Bearing Replacement

1. Remove the output shaft guard.
2. Remove the belt guard cover, lubrication hose and top belt guard. Remove the drive belts. Refer to "Drive Belt Replacement" page 18 for procedure.
3. Remove the drive pulley. Refer to "Drive and Rotor Pulley Replacement" page 20 for procedure.
4. Scribe a line on the output shaft bearing mounting bracket as shown in Figure 43 page 24 to establish the location of the new bearing when reassembling.
5. Remove the two set screws in the bearing lock collar, two capscrews, flatwashers, lockwashers and hex-nuts securing the output shaft bearing. Loosen the output shaft center bearing cap screws. Lift up on the output shaft and remove the shims from under the output shaft bearing, see Figure 44 page 24.

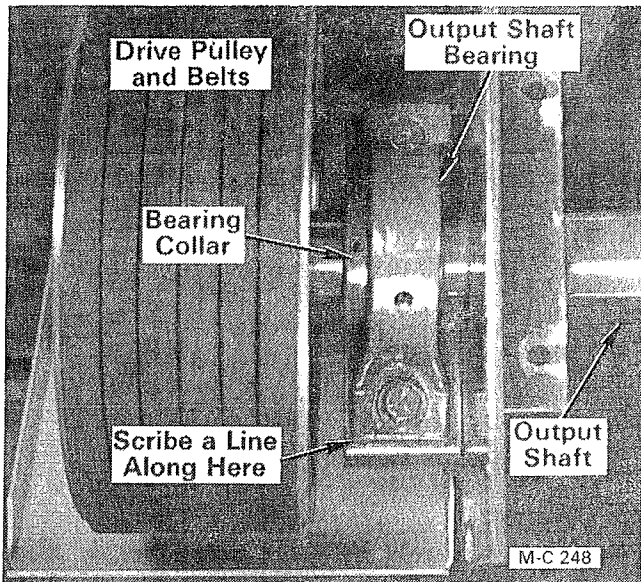

Figure 43

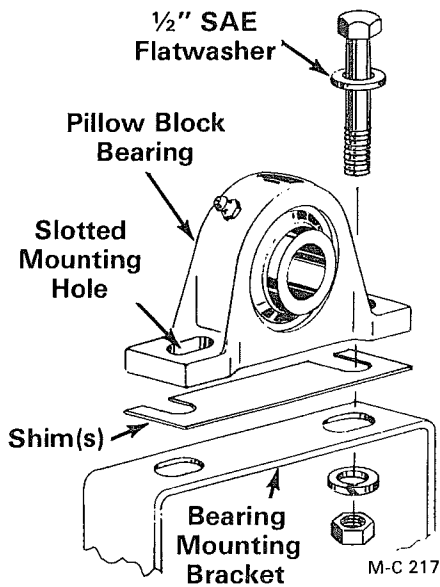

Figure 44

6. Clean the output shaft with emery cloth. Support the output shaft and pull the bearing off of the output shaft.
7. Lightly polish the output shaft with emery cloth. Lubricate the output shaft with motor oil and slide the new bearing onto the shaft. Be sure that the lubrication fitting faces the front of the Shredder.
8. Install the drive pulley. Refer to "Drive and Rotor Pulley Replacement" page 20 for procedure. Do not tighten the capscrews in the pulley bushing until the drive belts are installed and pulley alignment has been checked.
9. Install the drive belts.

10. Lift up on the output shaft and place the shims on the output shaft bearing mounting bracket, see Figure 44. Install the capscrews, SAE flatwashers, lockwashers and hex-nuts. Align the edge of the output shaft bearing with the mark scribed on the mounting bracket made in step 4, see Figure 43. Tighten the output shaft bearing capscrews and two set screws in the bearing lock collar. Tighten the center bearing capscrews.
11. Check drive and rotor pulley alignment. Refer to "Drive and Rotor Pulley Alignment" page 19 for procedure (torque drive pulley bushing capscrews) to 60 ft. lbs. Check idler pulley alignment. Refer to "Idler Pulley Alignment" page 19 for procedure.
12. Install the top belt guard, lubrication hose, belt guard cover and output shaft guard.
13. Lubricate the output shaft bearing with a hand grease gun. Do not over lubricate. Too much grease may damage the bearing seal.
14. Adjust the drive belt tension. Refer to "Drive Belt Adjustment" page 18.

Output Shaft Center Bearing Replacement

1. Remove the output shaft guard.
2. Remove the belt guard cover and top belt guard. Remove the drive belts. Refer to "Drive Belt Replacement" page 18 for procedure.
3. Scribe a line on the output shaft outer bearing mounting bracket to establish the location of the bearing for reassembly, see Figure 43. Remove the two capscrews, flatwashers, lockwashers and hex nuts securing the output shaft bearing to the bearing mount.
4. Remove the two set screws in the output shaft center bearing lock collar.
5. Remove the set screw and roll pin securing the output shaft to the universal joint yoke. Pull the output shaft out of the universal joint yoke and remove the key in the end of the output shaft. Save the shim(s) that are under the output shaft outer bearing.
6. Pull the output shaft out of the center bearing. Remove the output shaft center bearing and shim(s) from the center bearing mount.

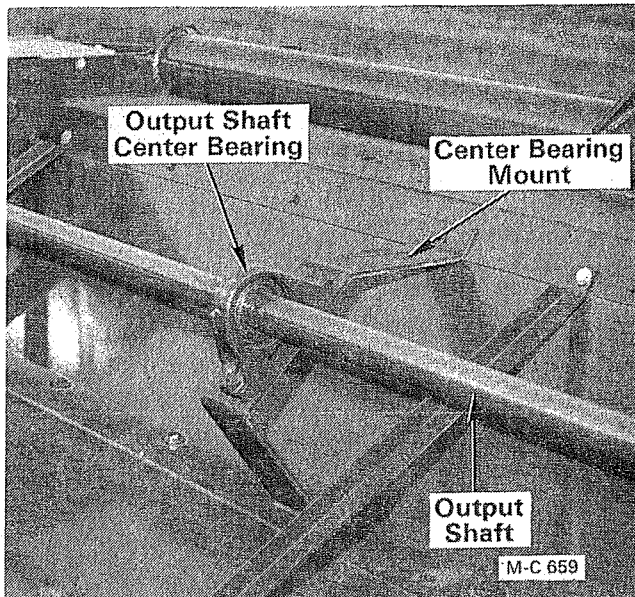

Figure 45

7. Place the new bearing on the center bearing mount with the lubrication fitting facing to the front, see Figure 45. Bolt the bearing to the bearing mount loosely. Loosen the two set screws in the bearing lock collar.
8. Slide the output shaft through the bearing on the center bearing mount. Install the $\frac{3}{8}$ " x $2\frac{1}{2}$ " key in the end of the output shaft.
9. Tap the output shaft into the output shaft universal joint until the drilled hole in the output shaft lines up with the hole in the universal joint end yoke. Tighten the set screw and install the $\frac{3}{8}$ " x 3" roll pin.
10. Lift up on the output shaft and place the shim(s) that were removed in disassembly on the outer output shaft bearing mounting bracket, see Figure 44. Install the capscrews, SAE flatwashers, lockwashers and hex-nuts. Align the edge of the output shaft bearing with the mark scribed on the mounting bracket made in step 3, see Figure 43. Tighten the output shaft bearing capscrews.
11. Check the fit of the new bearing to the center bearing mount. If there is a space between them add shims as required under the bearing. Tighten the bearing mounting capscrews and the two set screws in the bearing lock collar.
12. Install the top belt guard, belt guard cover and output shaft guard.
13. Lubricate both output shaft bearings with a hand grease gun. Do not over lubricate. Too much grease may damage the bearing seal.
14. Adjust the drive belt tension. Refer to "Drive Belt Adjustment" page 18.

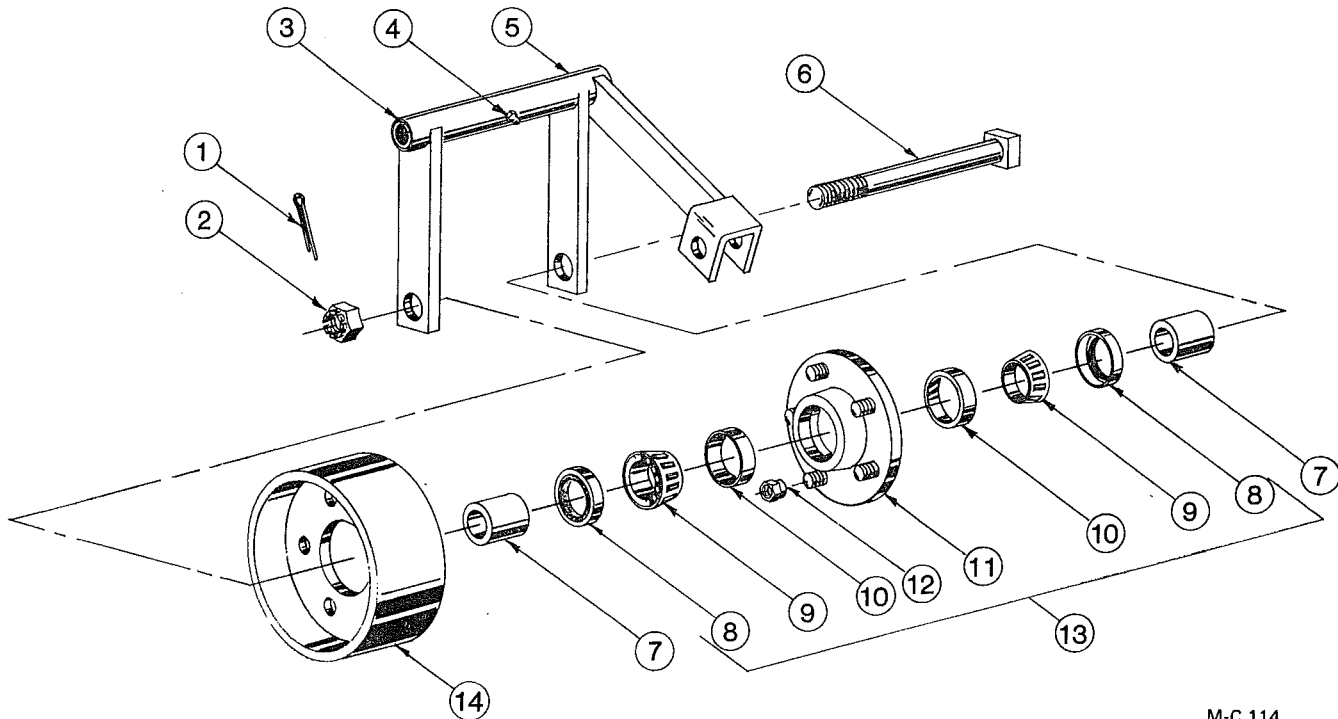

Figure 46

M-C 114

Idler Pulley Bearing Replacement

(Reference Nos. Refer to Figure 46)

1. Remove the belt guard cover, top belt guard and back belt guard.
2. Loosen the idler spring jam nut and back off the adjusting nut to relieve all spring tension. Disconnect the idler push rod at the idler arm.
3. Pull the idler push rod out of the idler spring bracket and remove the idler push rod and spring assembly.
4. Remove the three capscrews, lockwashers and hex nuts securing the idler pivot support to the Shredder body, see Figure 47 & 48. Remove the idler pivot support and pull the idler pulley assembly off of the idler pivot
5. Remove cotter pin (1), castellated nut (2) and idler bolt (6) from the idler arm (5).
6. Use an internal puller, see Figure 49, to remove the bearing seals (8) and bearing cups (10).
7. Pack the new bearing cones (9) with a good grade of wheel bearing grease. Press the bearing cups (10) into the hub, install bearing cones (9) and press in the bearing seals (8).
8. Put a hub spacer (7) on each side of the hub assembly and place the assembly in the idler arm (5). Install idler bolt (6) and castellated nut (2). Tighten the nut just enough to hold the assembly together.
9. Place the idler pulley assembly on the idler pivot. Install the idler pivot support, see Figure 47 & 48. Do not tighten the capscrews until after the idler pulley alignment has been checked.
10. Tighten the idler bolt castellated nut until it is snug to take all end play out of the bearings. Back off the nut to the next slot that lines up with the cotter pin hole.
11. Hit the end of the idler bolt with a mallet and check to see if there is any end play in the pulley. If there is none, install the cotter pin. If there is end play, repeat the procedure until all end play is taken up and install the cotter pin.
12. Lubricate the idler arm bushings. Check idler pulley alignment. Refer to "Idler Pulley Alignment" page 19 for procedure.
13. Install the idler push rod and spring assembly into the idler spring bracket. Connect the idler push rod to the idler arm.
14. Install the back belt guard, top belt guard and belt guard cover.

15. Turn the idler spring adjustment nut clockwise until the spring retainer is up to, but not tight against, the spring spacer.
16. Adjust the drive belt tension. Refer to "Drive Belt Adjustment" page 18.

Storing the Shredder

1. When the Shredder is to be stored for an extended period of time or at the end of the season, lubricate all bearings with enough grease to eliminate any cavities where water condensation may occur and cause damage. Refer to "Lubrication" page 14 for location of all grease fittings. Be sure the vent on top of the gear box is open.

IMPORTANT: Use a hand grease gun. Do not over lubricate. Too much grease may damage the bearing seals.

2. If the Shredder is equipped with the optional end tow system, lubricate the transport axle liberally to eliminate water condensation.
3. Loosen the drive belt tension spring jam nut and back off the adjustment nut to relieve the drive belt tension.

NOTE: Before next seasons use, be sure to adjust the drive belt tension. Refer to "Drive Belt Adjustment" page 18 for procedure.

4. Coat all exposed surfaces inside the Shredder with oil or grease to prevent rusting and pitting during storage.

Pre-Season Check

1. Inflate the tires to 32 lbs.
2. Check the oil level in the gear box and lubricate all bearings. See "Lubrication" page 14.
3. Adjust the drive belt tension, See "Drive Belt Adjustment" page 18.
4. Inspect for missing and/or broken knives. Replace as necessary. See "Knife Replacement" page 16.
5. Be sure all safety shields are in place and secure.
6. Run the Shredder at low RPM checking to make sure that all drive line parts are moving freely.

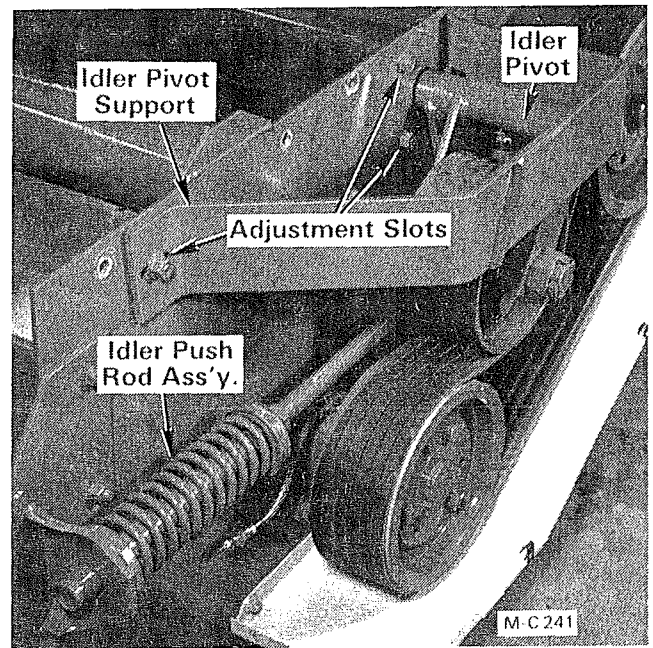

Figure 47

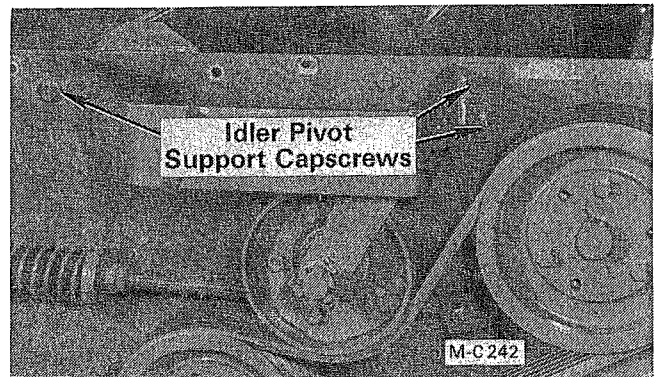

Figure 48

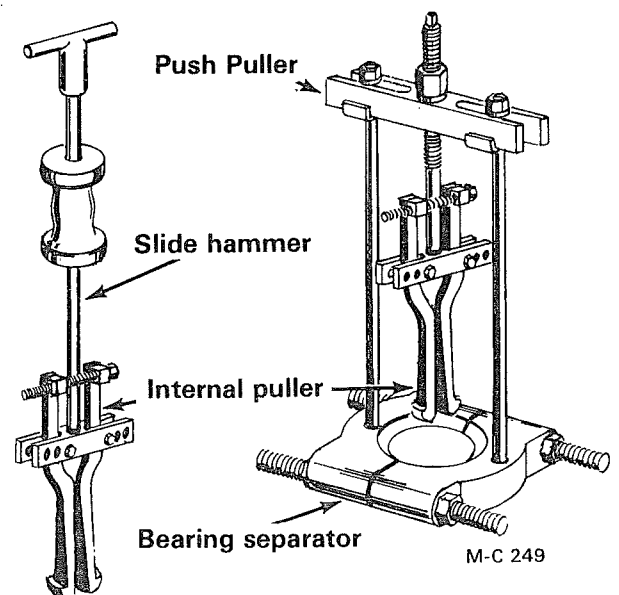
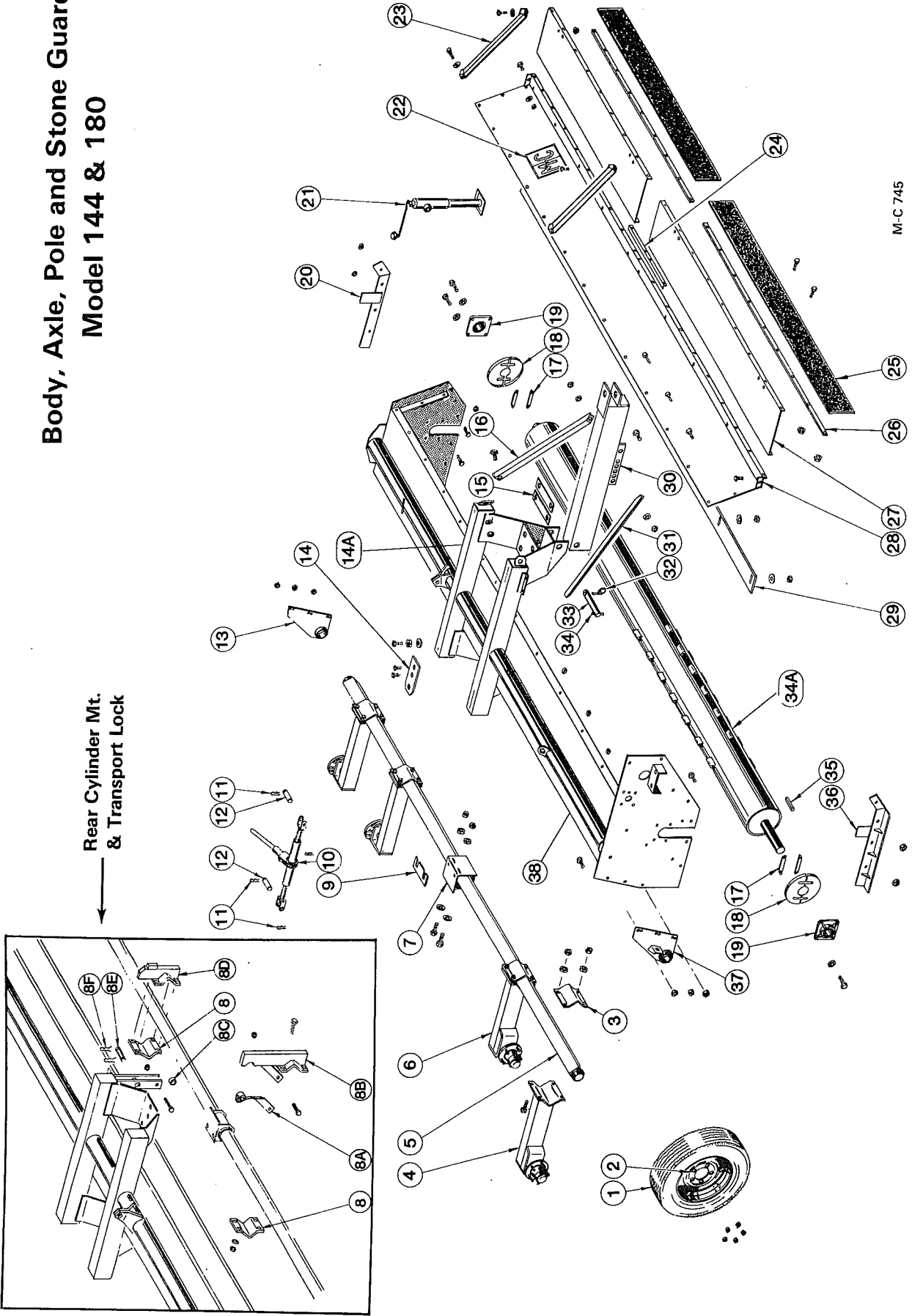

Figure 49

**Body, Axle, Pole and Stone Guard
Model 144 & 180**

PARTS



M-C 745

NOTE: Attaching hardware is listed, but not included with, the main part. It must be ordered separately.

Body, Axle, Pole and Stone Guard Model 144 & 180

Ref.	Part No.	Qty.	Description
1	000 8999	4	6.40 x 15", 6 Ply Tubeless Tire
2	001 8993	4	15" 5 Bolt Rim
3	111 3590	4	Mount Clamp (Axle)
4	111 1066	4	Wheel Mount & Hub Ass'y (See page 47)
5	111 0150	1	Model 144 Axle Weld.
	111 1049	1	Model 180 Axle Weld.
6	111 1041	4	Wheel Mount Ass'y. w/Clamp (See page 47)
7	111 0119	1	Axle Center Bearing Weldment
	000 8146	2	5/8-11 x 1 1/2" Hex-Hd. Capscrew - Grade 5
	000 8181	2	5/8" Lockwasher
	000 8121	2	3/8-16 x 1" Hex-Hd. Capscrew
	000 8174	4	3/8" Flatwasher
	001 8149	2	3/8-16 Two Way Locknut
8	111 0183	2	Mount Clamp - Reinforced
8A	111 0166	1	Floating Link
	000 8278	1	1/2-13 x 3/4" Hex-Hd. Capscrew - Grd. 5
	128 8164	1	1/2-13 Two Way Locknut
8B	111 1067	1	Cylinder Rear Mt. Ass'y. (Incl. ref. 8, 8A & hdwe.)
	111 0164	1	Cylinder Rear Mt. (Less ref. 8, 8A & hdwe.)
	128 8196	4	3/4-10 x 2 1/2" Hex-Hd. Capscrew - Grd. 5
	000 8182	4	3/4" Lockwasher
	000 8165	4	3/4-10 Hex Nut
8C	111 5410	1	Stop Bar - Spacer
	128 8166	1	1/2-13 x 2 1/2" Hex-Hd. Capscrew - Grd. 5
	000 8180	1	1/2" Lockwasher
	000 8163	1	1/2-13 Hex Nut
8D	111 1068	1	Transport Lock Ass'y. (Incl. ref. 8 & hdwe.)
	111 0163	1	Transport Lock Arm (Less ref. 8 & hdwe.)
	128 8196	4	3/4-10 x 2 1/2" Hex-Hd. Capscrew - Grd. 5
	000 8182	4	3/4" Lockwasher
	000 8165	4	3/4-10 Hex Nut
8E	001 8248	1	Transport Lock Pin - 1" x 3 1/2"
8F	000 8252	2	Hair Cotter Pin - 3/16"
9	128 2849	AR	Shim
10	001 8985	1	Mechanical Ratchet Jack - Optional
11	002 8253	4	Pin Clip
12	002 8254	2	Ratchet Jack Pin (1" x 2 3/4")
13	141 0018	1	Axle Mount - Left
	000 8137	3	1/2-13 x 1 1/4" Hex-Hd. Capscrew - Grade 5
	000 8180	3	1/2" Lockwasher
	000 8163	3	1/2-13 Hex Nut
14	111 3679	1	Disc Hitch Tongue
	128 8195	2	3/4-10 x 2" Hex-Hd. Capscrew - Grade 5
	000 8182	2	3/4" Lockwasher
	000 8165	2	3/4-10 Hex Nut
14A	001 8311	1	Decal - Operate Knives 2"
15	127 3404	2	Gear Box Mount Stiffener
16	111 0129	1	Pole Support Angle - Left
	128 8195	2	3/4-10 x 2" Hex-Hd. Capscrew - Grade 5
	000 8182	2	3/4" Lockwasher
	000 8165	2	3/4-10 Hex Nut
17	111 5182	4	Nut Bar
18	111 5709	4	Anti-Wrap Half
19	111 6003	2	Flange Bearing - 2-3/16", 4 Bolt w/Zerk

Continued on next page

Body, Axle, Pole and Stone Guard Model 144 & 180

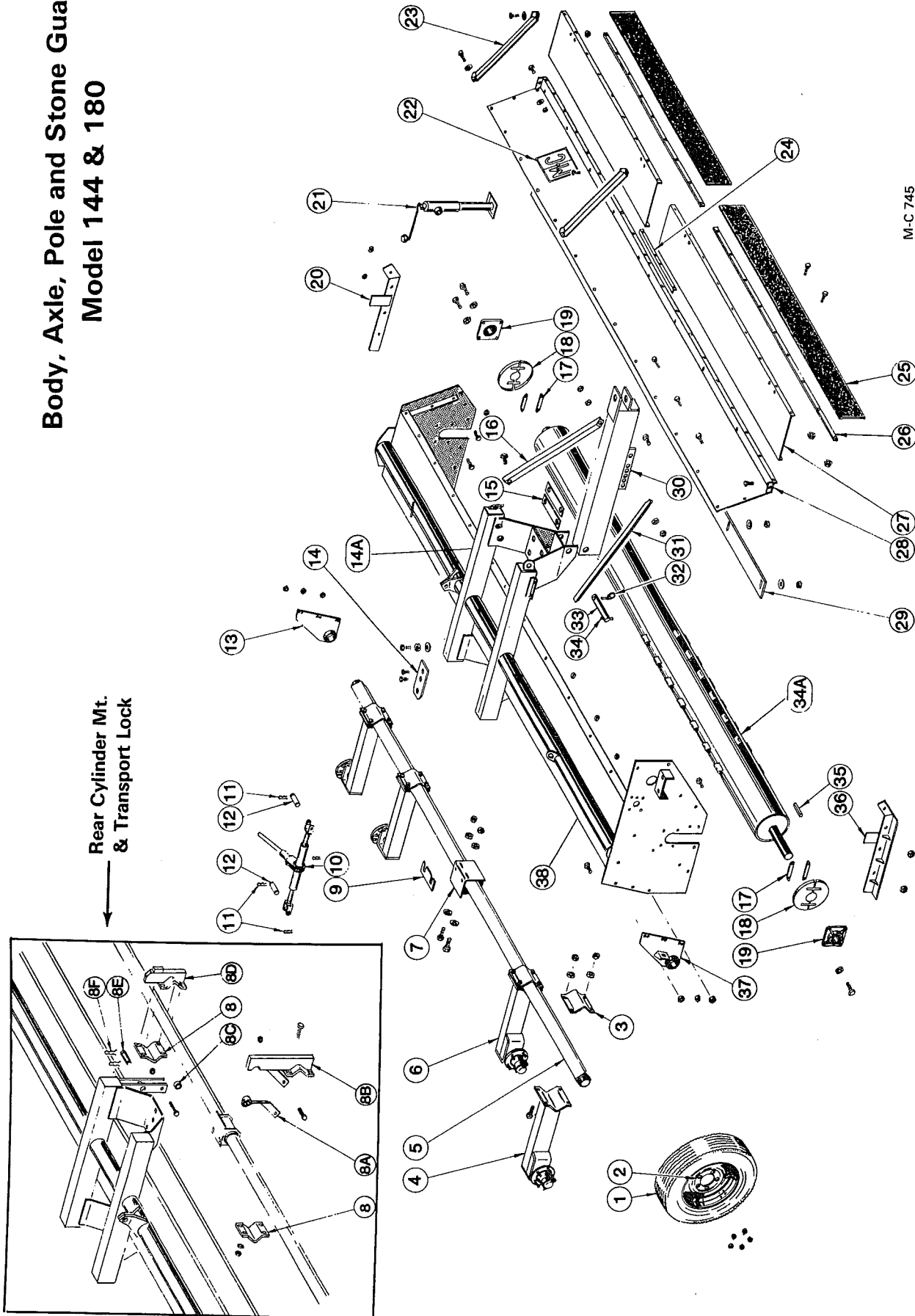

M-C 745

NOTE: Attaching hardware is listed, but not included with, the main part. It must be ordered separately.

Body, Axle, Pole and Stone Guard Model 144 & 180

Ref.	Part No.	Qty.	Description
20	091 8170	8	5/8"-11 x 1 3/4" Hex Hd. Capscrew - Grade 5 w/NY Patch
	000 8181	8	5/8" Lockwasher
	111 0109	1	Left Skid
	000 8135	4	1/2-13 x 1" Hex-Hd. Capscrew
	128 8164	4	1/2-13 Two Way Locknut
21	141 8997	1	Pole Jack w/Retaining Pin
22	001 8302	2	M-C Decal - 8-3/16" x 9"
23	111 0162	—	Stone Guard Support (4 on Model 144 & 6 on Model 180)
	001 8135	—	3/8-16 x 1" Hex-Hd. Capscrew - Grade 5
	000 8174	—	3/8" Flatwasher
	001 8149	—	3/8-16 Two Way Locknut
24	111 3486	1	Cover Support Angle
	000 8290	2	3/8-16 x 1 1/2" Hex-Hd. Capscrew
	000 8174	2	3/8" Flatwasher
	001 8139	2	3/8" Lockwasher
	000 8162	2	3/8"-16 Hex Nut
25	111 5716	2	Model 144 Stone Guard Flap
	111 5715	2	Model 180 Stone Guard Flap
26	111 2050	2	Model 144 Retaining Strip
	111 2051	2	Model 180 Retaining Strip
	001 8135	—	3/8-16 x 1" Hex-Hd. Capscrew - Grade 5
27	001 8149	—	3/8-16 Two Way Locknut
	111 4456	2	Model 144 Stone Guard
	111 4457	2	Model 180 Stone Guard
	001 8148	—	3/8-16 x 3/4" Hex-Hd. Capscrew - Grade 5
	001 8149	—	3/8-16 Two Way Locknut
	111 0146	1	Model 144 Front Cover
	111 0147	2	Model 180 Front Cover
	111 4446	1	Model 180 Front Cover Splice (Not Shown)
	000 8119	—	3/8-16 x 3/4" Hex-Hd. Capscrew
	000 8121	—	3/8-16 x 1" Hex-Hd. Capscrew
	000 8174	—	3/8" Flatwasher
	001 8149	—	3/8-16 Two Way Locknut
29	000 3470	2	Model 144 Cutter Bar
	111 3483	2	Model 180 Cutter Bar
	000 8137	—	1/2-13 x 1 1/4" Hex-Hd. Capscrew - Grade 5
	000 8175	—	1/2" Flatwasher
	000 8180	—	1/2" Lockwasher
	000 8163	—	1/2-13 Hex Nut
30	111 0105	1	Pole
31	111 0128	1	Pole Support Angle - Right
	128 8195	2	3/4-10 x 2" Hex-Hd. Capscrew - Grade 5
	000 8182	2	3/4" Lockwasher
	000 8165	2	3/4-10 Hex Nut
32	000 8994	1	Klick Pin 1/4" Dia.
33	111 1035	1	Pole Pin w/Roll Pin 000 8259
34	000 8259	1	Roll Pin 5/16" x 1 3/4"
34A	---	1	Rotor Ass'y. (See page 40)
35	001 5147	1	Key 1/2" x 1/2" x 3"
36	111 0108	1	Right Skid
	000 8135	4	1/2-13 x 1" Hex-Hd. Capscrew
	128 8164	4	1/2-13 Two Way Locknut
37	111 0117	1	Axle Mount - Right
	000 8137	3	1/2-13 x 1 1/4" Hex-Hd. Capscrew - Grade 5
	000 8180	3	1/2" Lockwasher
	000 8163	3	1/2-13 Hex Nut
38	001 8316	1	Safety Decal - Danger

Body, Axle, Pole and Stone Guard Model 2408

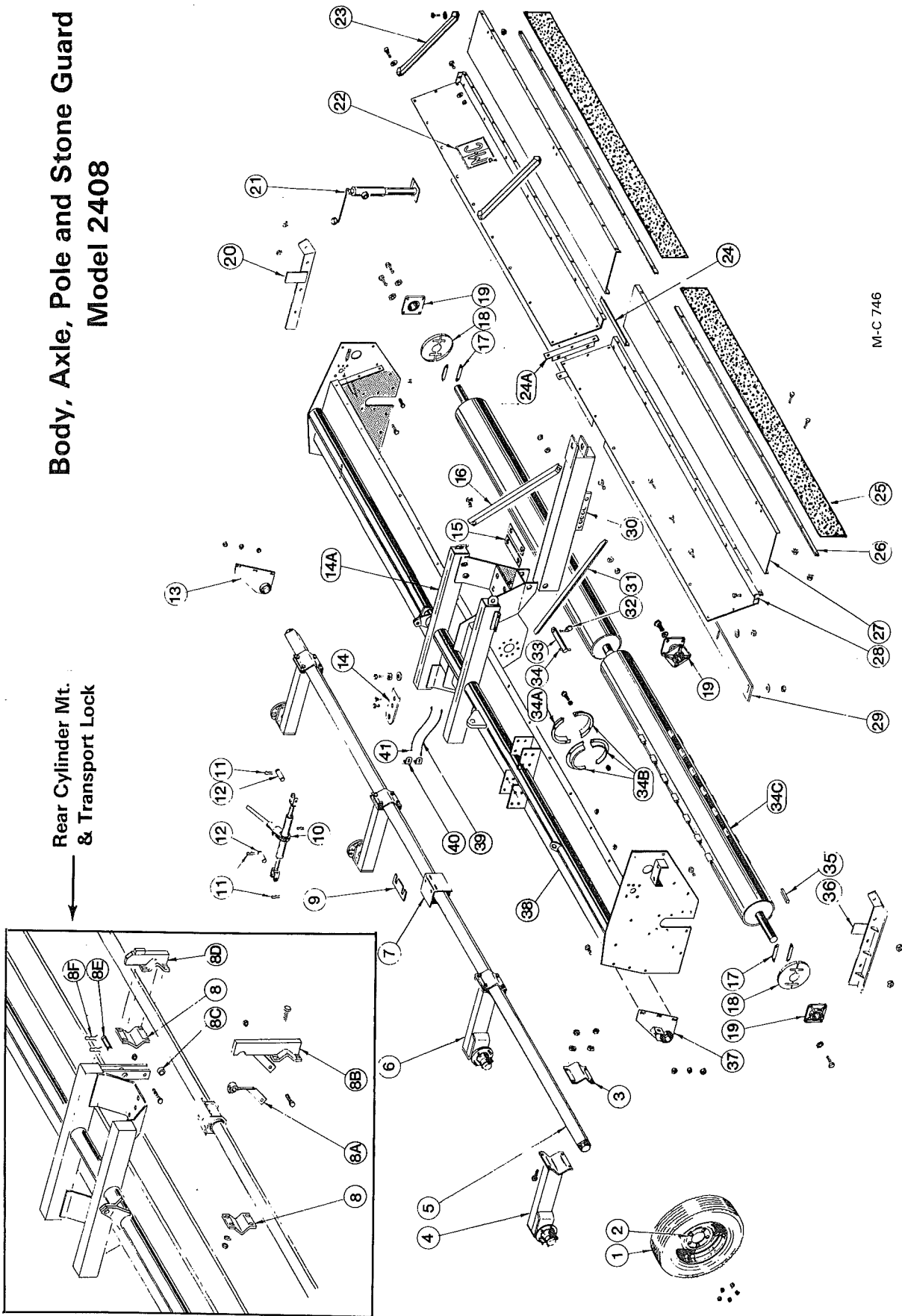

NOTE: Attaching hardware is listed, but not included with, the main part. It must be ordered separately.

Body, Axle, Pole and Stone Guard Model 2408

Ref.	Part No.	Qty.	Description	Ref.	Part No.	Qty.	Description
091	8981	4	Flotation Tire Complete (Incl. 1 ea. of ref. 1 & 2)	8E	001 8248	1	Transport Lock Pin 1" x 3 1/2"
1	092 8983	4	7.50 x 10E 10 Ply Tire and Tube	8F	000 8252	2	Hair Cotter Pin - 3/16"
2	092 8984	4	Wheel - 6" Wide x 10" Dia.	9	128 2849	AR	Shim
3	111 3590	4	Mount Clamp (Axle)	10	001 8985	1	Mechanical Ratchet Jack (Optional)
4	111 1083	4	Wheel Mount & Hub Ass'y. (See page 47)	11	002 8253	4	Ratchet Jack Pin Clip
5	111 0172	1	Axle Weldment	12	002 8254	2	Ratchet Jack Pin (1" x 2 3/4")
6	111 1082	4	Wheel Mount Ass'y. w/Clamp (See page 47)	13	111 0182	1	Axle Mount - Left
	111 0119	1	Axle Center Bearing Weldment		000 8137	3	1/2-13 x 1 1/4" Hex-Hd. Capscrew - Grade 5
	000 8146	2	5/8-11 x 1 1/2" Hex-Hd. Capscrew - Grade 5		000 8180	3	1/2" Lockwasher
	000 8181	2	5/8" Lockwasher		000 8163	3	1/2-13 Hex Nut
8	111 0183	2	Mount Clamp - Reinforced	14	111 3679	1	Disc Hitch Tongue
8A	111 0166	1	Floating Link		128 8195	2	3/4-10 x 2" Hex-Hd. Capscrew - Grade 5
	000 8278	1	1/2-13 x 1 3/4" Hex-Hd. Capscrew - Grade 5		000 8182	2	3/4" Lockwasher
	128 8164	1	1/2-13 Two Way Locknut		000 8165	2	3/4-10 Hex Nut
8B	111 1067	1	Cylinder Rear Mt. Ass'y. (Incl. ref. 8, 8A & hdwe.)	14A	001 8311	1	Decal - Operate Knives 2"
	111 0164	1	Cylinder Rear Mt. (Less ref. 8, 8A & hdwe.)	15	127 3404	2	Gear Box Mount Stiffener
	128 8196	4	3/4-10 x 2 1/2" Hex-Hd. Capscrew - Grade 5	16	111 0129	1	Pole Support Angle - Left
	000 8182	4	3/4" Lockwasher		128 8195	2	3/4-10 x 2" Hex-Hd. Capscrew - Grade 5
	000 8165	4	3/4-10 Hex Nut		000 8182	2	3/4" Lockwasher
8C	111 5410	1	Stop Bar - Spacer		000 8165	2	3/4-10 Hex Nut
	128 8166	1	1/2-13 x 2 1/2" Hex-Hd. Capscrew - Grade 5	17	111 5182	4	Nut Bar
	000 8180	1	1/2" Lockwasher	18	111 5709	4	Anti-Wrap Half (For drive end of rotor)
	000 8163	1	1/2-13 Hex Nut	19	111 6003	4	Flange Brg.-2-3/16" 4 Bolt w/Zerk
8D	111 1068	1	Transport Lock Ass'y. (Incl. ref. 8 & hdwe.)		091 8170	16	5/8-11 x 1 3/4" Hex-Hd. Capscrew - Grd. 5 w/NY Patch
	111 0163	1	Transport Lock Arm (Less ref. 8 & hdwe.)		000 8181	16	5/8" Lockwasher
	128 8196	4	3/4-10 x 2 1/2" Hex-Hd. Capscrew - Grade 5		000 8164	8	5/8-11 Hex Nut
	000 8182	4	3/4" Lockwasher	20	111 0109	1	Left Skid
	000 8165	4	3/4-10 Hex Nut		000 8135	4	1/2-13 x 1" Hex-Hd. Capscrew
					128 8164	4	1/2-13 Two Way Locknut
				21	141 8997	1	Pole Jack w/Retaining Pin
				22	001 8302	2	M-C Decal 8-3/16" x 9"

Continued on next page

Body, Axle, Pole and Stone Guard Model 2408

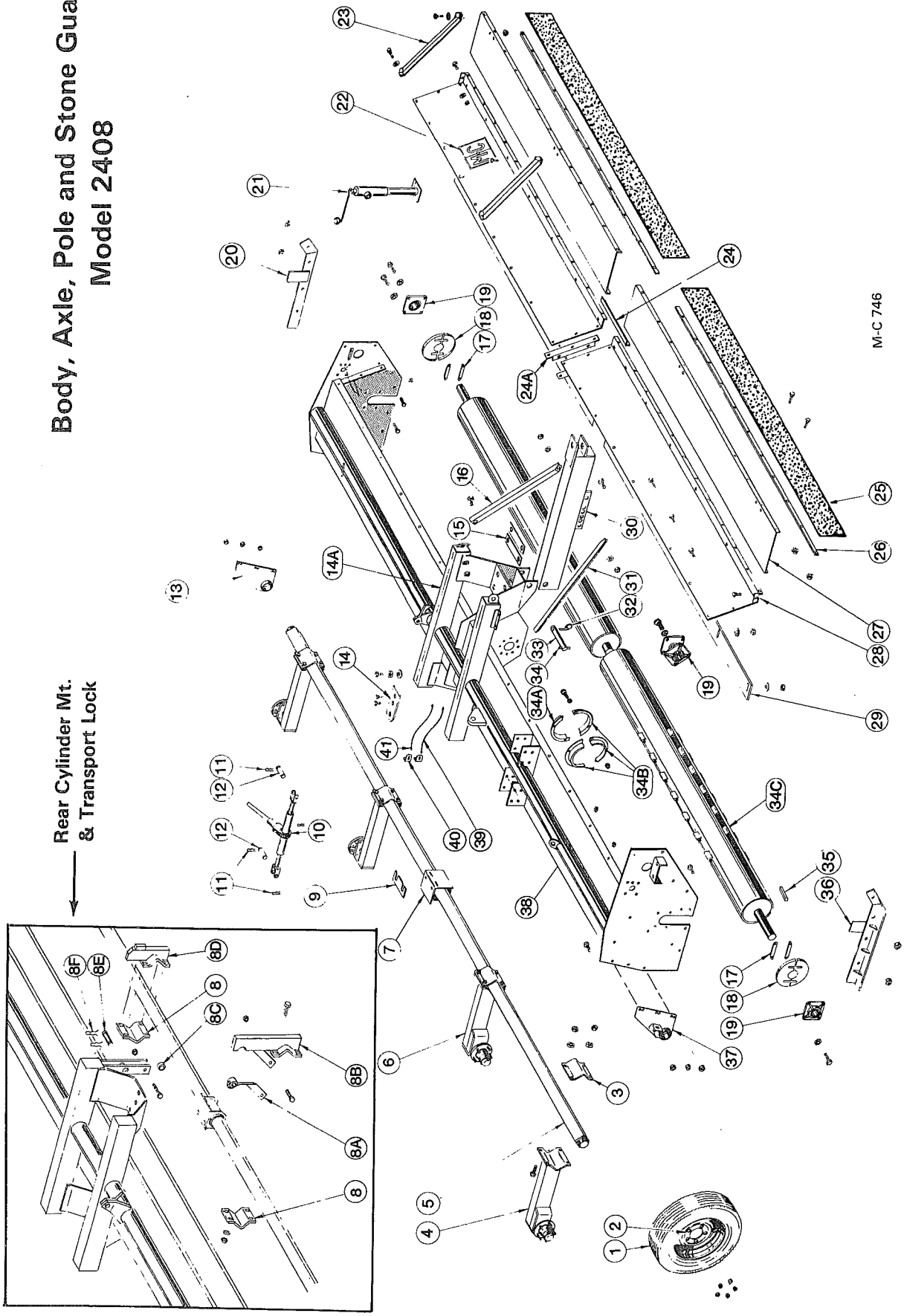

M-C 746

NOTE: Attaching hardware is listed, but not included with, the main part. It must be ordered separately.

Ref.	Part No.	Qty.	Description	Ref.	Part No.	Qty.	Description
23	111 0162	6	Stone Guard Support	000 8175	26	1/2" Flatwasher	
	001 8135	12	3/8-16 x 1" Hex-Hd. Capscrew - Grade 5	000 8180	26	1/2" Lockwasher	
	000 8174	12	3/8" Flatwasher	000 8163	26	1/2-13 Hex Nut	
	001 8139	12	3/8" Lockwasher	30	111 0105	1 Pole	
	000 8162	12	3/8-16 Hex Nut	31	111 0128	1 Pole Support Angle - Right	
24	111 3486	1	Cover Support Angle	128 8195	2	3/4-10 x 2" Hex-Hd. Capscrew - Grade 5	
	000 8290	2	3/8-16 x 1 1/2" Hex-Hd. Capscrew	000 8182	2	3/4" Lockwasher	
	000 8174	2	3/8" Flatwasher	000 8165	2	3/4-10 Hex Nut	
	001 8139	2	3/8" Lockwasher	32	000 8994	1 Klick Pin 1/4" Dia.	
	000 8162	2	3/8-16 Hex Nut	33	111 1035	1 Pole Pin w/Roll Pin 000 8259	
24A	111 4470	2	Front Cover Center Bracket	34	000 8259	1 Roll Pin 5/16" x 1 3/4"	
	001 8144	4	3/8-16 x 1 1/4" Hex-Hd. Capscrew	34A	111 5982	1 Anti-Wrap Half (For upper left side on stub shaft end of rotor)	
	000 8168	4	3/8-16 Flanged Locknut	34B	111 5981	3 Anti-wrap half (For right side and lower left side on stub shaft end of rotor)	
25	111 5720	2	Stone Guard Flap				
26	111 2052	2	Retaining Strip	001 8144	4	3/8-16 x 1 1/4" Hex-Hd. Capscrew - Grade 5	
	001 8135	30	3/8-16 x 1" Hex-Hd. Capscrew - Grade 5	001 8139	4	3/8" Lockwasher	
	001 8139	30	3/8" Lockwasher	000 8162	4	3/8-16 Hex Nut	
	000 8162	30	3/8-16 Hex Nut	34C	---	---	
27	111 4466	2	Stone Guard	001 5147	2	Rotor Ass'y. (See page 41)	
	001 8135	30	3/8-16 x 1" Hex-Hd. Capscrew - Grade 5	35	001 5147	2 Key 1/2" x 1/2" x 3"	
	001 8139	30	3/8" Lockwasher	36	111 0108	1 Right Skid	
	000 8162	30	3/8-16 Hex Nut	000 8135	4	1/2-13 x 1" Hex-Hd. Capscrew	
28	111 0173	2	Front Cover	128 8164	4	1/2-13 Two Way Locknut	
	000 8119	20	3/8-16 x 3/4" Hex-Hd. Capscrew	111 0117	1	Axle Mount Right	
	000 8121	8	3/8-16 x 1" Hex-Hd. Capscrew	000 8137	3	1/2-13 x 1 1/4" Hex-Hd. Capscrew - Grade 5	
	000 8174	8	3/8" Flatwasher	000 8180	3	1/2" Lockwasher	
29	000 8168	28	3/8-16 Flanged Locknut	000 8163	3	1/2-13 Hex Nut	
	111 3493	2	Cutter Bar	001 8316	1	Safety Decal - Danger	
	133 8161	2	1/2-13 x 1 1/2" Hex-Hd. Capscrew - Grade 5	39	111 5550	2 Center Rotor Brg. Grease Tube - 27"	
	000 8137	22	1/2-13 x 1 1/4" Hex-Hd. Capscrew - Grade 5	40	001 3302	2 Angle Clip	
				41	111 8700	4 Male Connector -1/8"	

Drive Line and Guards Model 144, 180 & 2408

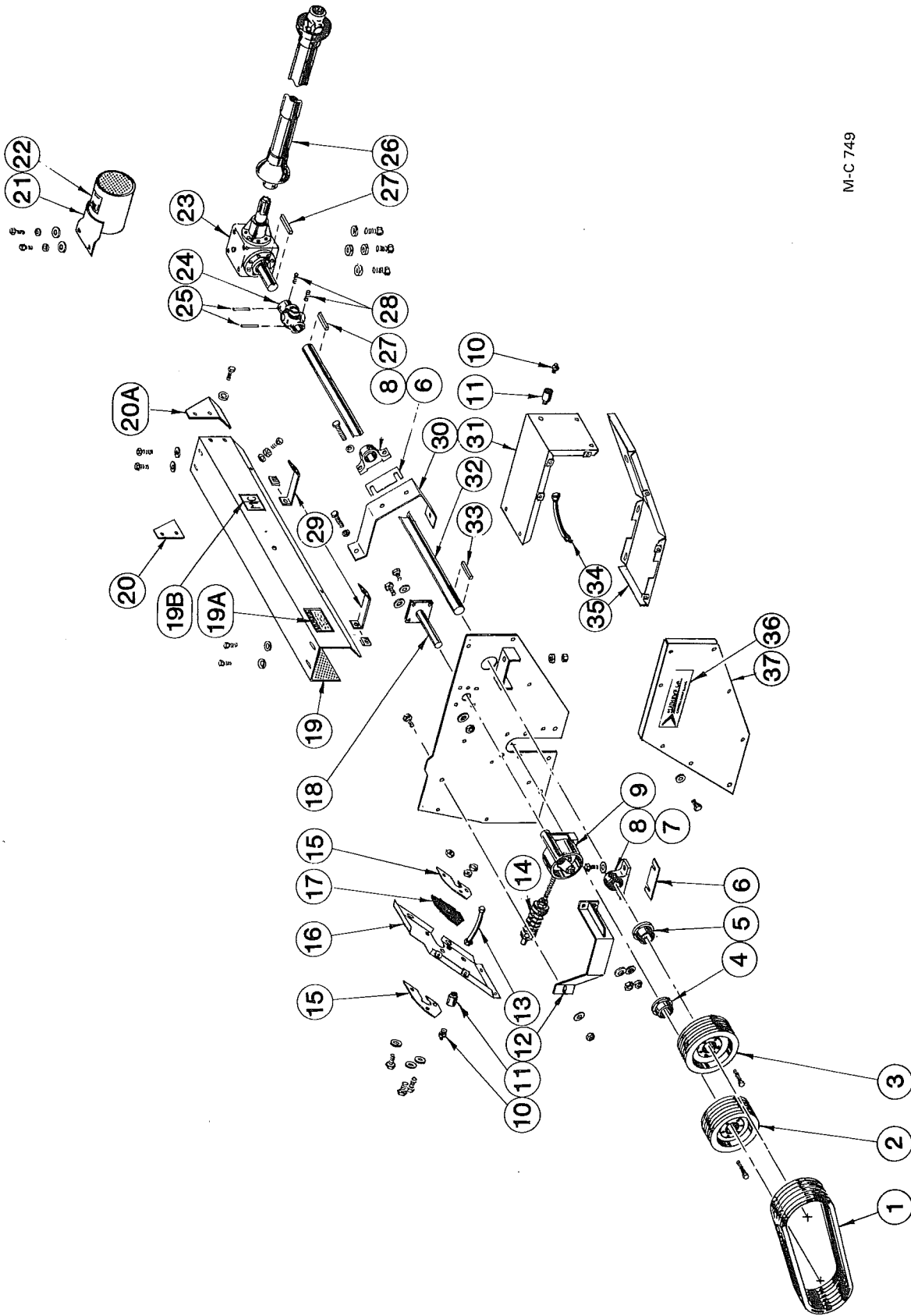

M-C 749

NOTE: Attaching hardware is listed, but not included with, the main part. It must be ordered separately.

Ref.	Part No.	Qty.		Description	Ref.	Part No.	Qty.		Description
		144 & 180	2408				144 & 180	2408	
1	111 6101	1	2	1/5V800-Matched Set of 6 Individual Belts	16	111 4779	1	1	Belt Guard Back - Right
2	111 6208	1	2	5V/10.3 x 6 Grv. "E" Rotor Pulley		111 4794	0	1	Belt Guard Back - Left
3	111 6202	1	2	5V/10.9 x 6 Grv. "E" Drive Pulley		001 8111	2	4	5/16-18 Clip Nut
4	111 6211	1	2	"E" Bushing 2-3/16" Bore (Incl. Capscrews & Lockwashers)		000 8134	2	4	3/8-16 x 3/4" Truss Hd. Screw
5	111 6205	1	2	"E" Bushing 1 3/4" Bore (Incl. Capscrews & Lockwashers)		001 8149	2	4	3/8-16 Two Way Locknut
6	125 2918	AR	AR	Bearing Shim - 16 Ga.	17	111 8985	1	2	Idle Bolt Seal (Rubber)
	001 2600	AR	AR	Bearing Shim - 11 Ga.	18	111 0115	1	2	Belt Idler Pivot
7	000 8989	2	4	1/8" NPT 90° Zerk ST. EL.		000 8137	4	8	1/2-13 x 1 1/4" Hex-Hd. Capscrew-Grade 5
8	091 6001	2	4	Output Shaft Bearing 1 3/4" Bore w/Zerk		001 8257	8	16	1/2" SAE Flatwasher
	000 8278	4	8	1/2-13 x 1 3/4" Hex-Hd. Capscrew-Grade 5		128 8164	4	8	1/2-13 Two Way Locknut
	001 8257	8	16	1/2" SAE Flatwasher	19	111 4790	1	0	Model 144 Output Shaft Guard
	000 8180	4	8	1/2" Lockwasher		111 4791	1	0	Model 180 Output Shaft Guard
	000 8163	4	8	1/2-13 Hex Nut		111 4798	0	1	Model 2408 Output Shaft Guard-Right
9	111 1028	1	1	Idler Ass'y. - Right (See page 45)		111 4799	0	1	Model 2408 Output Shaft Guard-Left
	111 1073	0	1	Idler Ass'y. - Left (See page 45)		001 8111	4	8	5/16-18 Clip Nut
10	002 6604	2	4	1/8" PT Straight Zerk		000 8106	4	8	5/16-18 x 3/4" Hex-Hd. Capscrew
	123 7503	2	4	Galvanized Coupling	19A	001 8315	1	2	Safety Decal - Warning
11	111 0116	1	1	Belt Idler Pivot Support - Right	19B	128 8300	1	2	M-C Decal - 4-9/16" x 5"
12	111 0174	0	1	Belt Idler Pivot Support - Left	20	111 4793	1	2	Output Shaft Guard Extension-Rear
	000 8137	3	6	1/2-13 x 1 1/4" Hex-Hd. Capscrew - Grade 5	20A	111 4792	1	1	Output Shaft Guard Extension - Front Right
	001 8257	4	8	1/2" SAE Flatwasher		111 4800	0	1	Output Shaft Guard Extension - Front Left
	128 8164	3	6	1/2-13 Two Way Locknut		000 8106	4	8	5/16-18 x 3/4" Hex-Hd. Capscrew
13	000 8984	1	2	Grease Hose (Rotor Bearing - 8")		000 8173	4	8	5/16" Flatwasher
14	----	---	---	Belt Idler Push Rod & Spring (See page 44)		000 8288	4	8	5/16-18 Two Way Locknut
15	111 4789	2	4	Idle Bolt Seal (16 Ga.)	21	---	1	1	Gear Box Input Shaft Guard
	000 8104	3	6	5/16-18 x 3/4" Truss Hd. Screw		000 8145	2	2	5/8-11 x 1 1/4" Hex-Hd. Capscrew - Grade 5
	000 8173	3	6	5/16" Flatwasher		000 8176	2	2	5/8" Flatwasher
	000 8288	3	6	5/16-18 Two Way Locknut		000 8181	2	2	5/8" Lockwasher

Continued on next page

Body, Axle, Pole and Stone Guard Model 2408

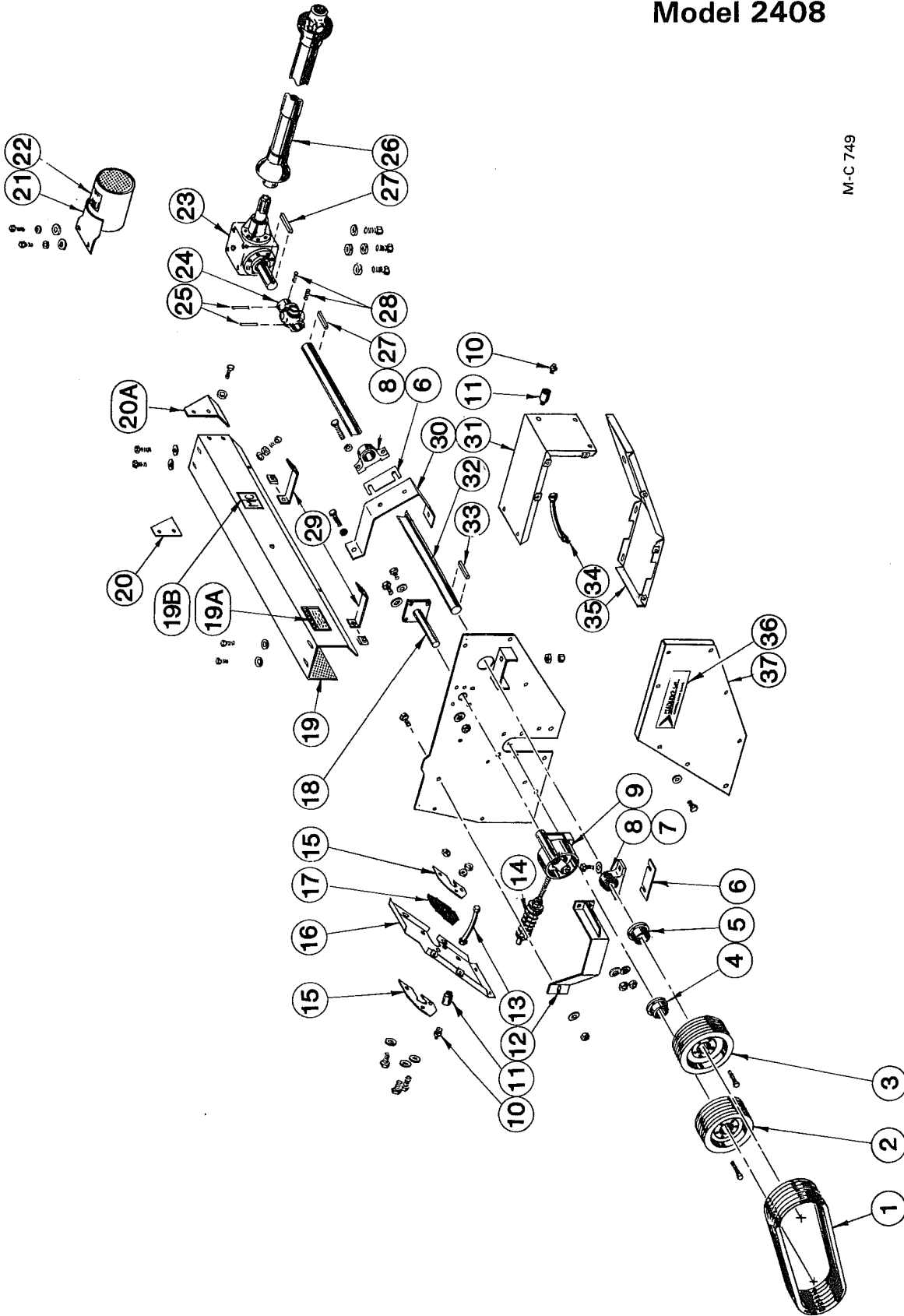

M-C 749

NOTE: Attaching hardware is listed, but not included with, the main part. It must be ordered separately.

Qty. 144 & Qty. 180		Qty. 144 & Qty. 2408			
Ref.	Part No.	Description	Ref.	Part No.	Description
22	001 8316	1 Safety Decal - Danger	32	111 5063	1 0 Model 144 Output Drive Shaft
23	091 6608	1 0 Gear Box (See page 42)		111 5064	1 0 Model 180 Output Drive Shaft
	111 6611	0 1 Gear Box (See page 43)		111 5191	0 2 Model 2408 Output Drive Shaft
	091 8170	4 4 5/8-11 x 1 3/4" Hex-Hd. Capscrew - Grade 5 w/NY Patch	33	001 5139	1 2 Key 3/8" x 3/8" x 3"
	000 8181	4 4 5/8" Lockwasher	34	000 8985	1 2 Grease Hose (Output Shaft Outer Bearing 10")
24	111 8988	1 2 Output Shaft Universal Joint (See page 47)	35	111 4781	1 1 Belt Guard Bottom - Right
25	001 8281	1 2 Roll Pin 3/8" x 3"		111 4796	0 1 Belt Guard Bottom - Left
26	111 6610	1 1 PTO Shaft - 1000 RPM (See page 46)		001 8111	3 6 5/16-18 Clip Nut
27	001 5136	2 4 Key 3/8" x 3/8" x 2 1/2"		000 8121	3 6 3/8-16 x 1" Hex-Hd. Capscrew
28	000 8234	2 4 Set Screw 1/2-13 x 3/8"		000 8174	3 6 3/8" Flatwasher
29	111 3404	2 4 Output Shaft Guard Brace		001 8149	3 6 3/8-16 Two Way Locknut
	001 8111	4 4 5/16-18 Clip Nut	36	001 8303	1 2 M-C Arrow-Decal
	000 8106	4 8 5/16-18 x 3/4" Hex-Hd. Capscrew	37	111 4768	1 1 Belt Guard Cover - Right
	000 8173	4 8 5/16" Flatwasher		111 4797	0 1 Belt Guard Cover - Left
30	111 3399	1 2 Output Shaft Center Brg. Mt.		000 8106	8 16 5/16-18 x 3/4" Hex-Hd. Capscrew
	001 8144	1 2 3/8-16 x 1 1/4" Hex-Hd. Capscrew - Grade 5		000 8173	8 16 5/16" Flatwasher
	001 8134	1 2 3/8" SAE Flatwasher			
	001 8149	1 2 3/8-16 Two Way Locknut			
	133 8161	1 2 1/2-13 x 1 1/2" Hex-Hd. Capscrew - Grade 5			
	001 8257	1 2 1/2" SAE Flatwasher			
	000 8180	1 2 1/2" Lockwasher			
	000 8163	1 2 1/2-13 Hex Nut			
31	111 4780	1 1 Belt Guard Top - Right			
	111 4795	0 1 Belt Guard Top - Left			
	001 8111	4 8 5/16-18 Clip Nut			
	000 8134	4 8 3/8-16 x 3/4" Truss Hd. Screw			
	000 8121	4 8 3/8-16 x 1" Hex-Hd. Capscrew			
	000 8174	4 8 3/8" Flatwasher			
	001 8149	4 8 3/8-16 Two Way Locknut			

Rotor Assembly

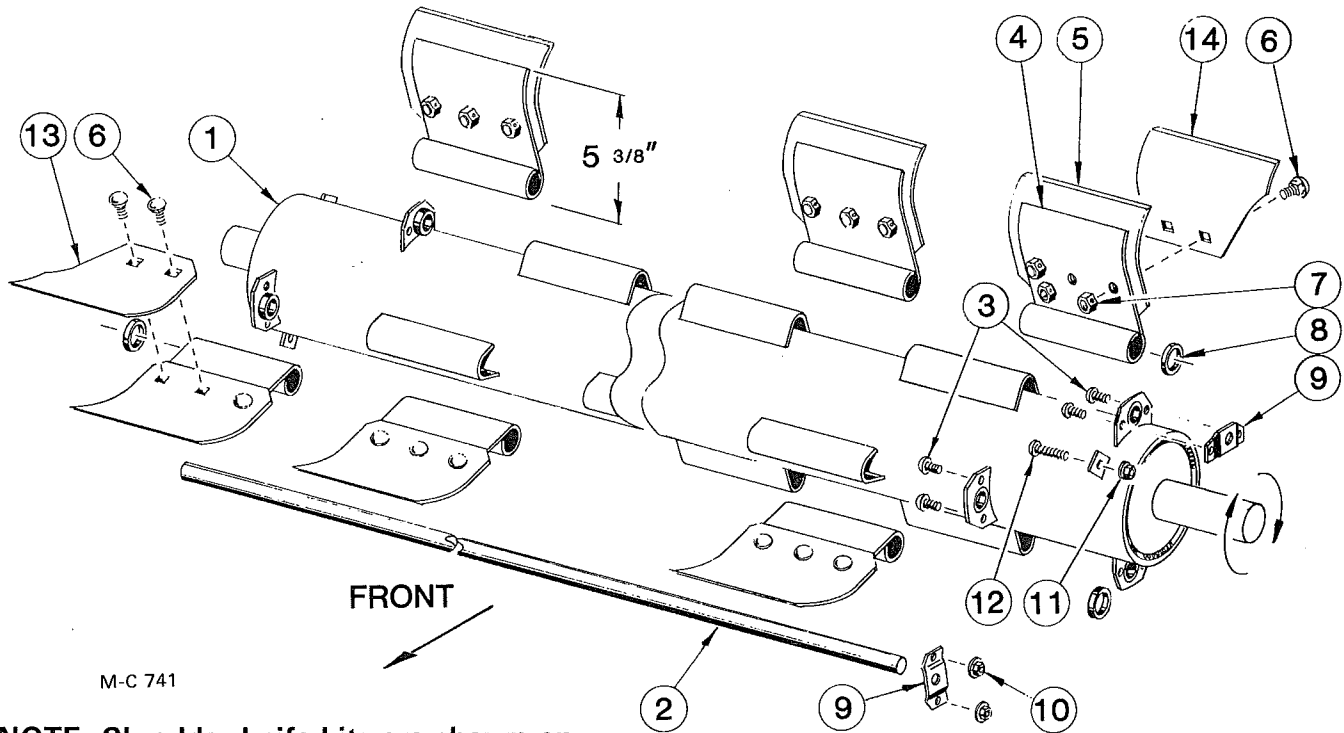

M-C 741

NOTE: Shredder knife kits are shown on page 44.

Model 144

Complete Assembly 111 1040

(Consists of ref. 1 thru 10 in quantities shown. Wipers, ref. 11 & 12 and end knives, ref. 13 and 14 must be ordered separately).

Model 180

Complete Assembly 111 1031

(Consists of ref. 1 thru 10 in quantities shown. Wipers ref. 11 & 12 and end knives, ref. 13 and 14 must be ordered separately).

Ref.	Part No.	Qty.	Description
1	111 0138	1	Balanced Rotor Weldment
2	001 8975	4	Rotor Hanger Bar 134 $\frac{3}{4}$ "
3	000 8134	16	$\frac{3}{8}$ -16 x $\frac{3}{4}$ " Truss Head Screw
4	111 5200	48	Wide Knife Hanger
5	001 5208	48	(HD) Wide Knife
6	001 8131	144	$\frac{3}{8}$ -16 x $\frac{7}{8}$ " Knife Carriage Bolt-Grade 8 (Special)
7	001 8149	144	$\frac{3}{8}$ -16 Two Way Lock Nut
8	- - - 6524	8	Knife Spacer
9	001 2000	8	End Locator Bracket
10	000 8168	16	$\frac{3}{8}$ -16 Flanged Whiz Lock Nut
11	000 8168	4	$\frac{3}{8}$ -16 Flanged Whiz Lock Nut
12	000 8125	4	$\frac{3}{8}$ -16 x 1 $\frac{1}{2}$ " Carriage Bolt
13	001 5212	2	End Knife - Right
14	001 5211	2	End Knife - Left

Ref.	Part No.	Qty.	Description
1	111 0121	1	Balanced Rotor Weldment
2	111 8984	4	Rotor Hanger Bar 102"
	111 8983	4	Rotor Hanger Bar 67 $\frac{1}{4}$ "
3	000 8134	16	$\frac{3}{8}$ -16 x $\frac{3}{4}$ " Truss Head Screw
4	111 5200	60	Wide Knife Hanger
5	001 5208	60	(HD) Wide Knife
6	001 8131	180	$\frac{3}{8}$ -16 x $\frac{7}{8}$ " Knife Carriage Bolt - Grade 8 (Special)
7	001 8149	180	$\frac{3}{8}$ -16 Two Way Lock Nut
8	- - - 6524	8	Knife Spacer
9	001 2000	8	End Locator Bracket
10	000 8168	16	$\frac{3}{8}$ -16 Flanged Whiz Lock Nut
11	000 8168	4	$\frac{3}{8}$ -16 Flanged Whiz Lock Nut
12	000 8125	4	$\frac{3}{8}$ -16 x 1 $\frac{1}{2}$ " Carriage Bolt
13	001 5212	2	End Knife - Right
14	001 5211	2	End Knife - Left

Rotor Assembly

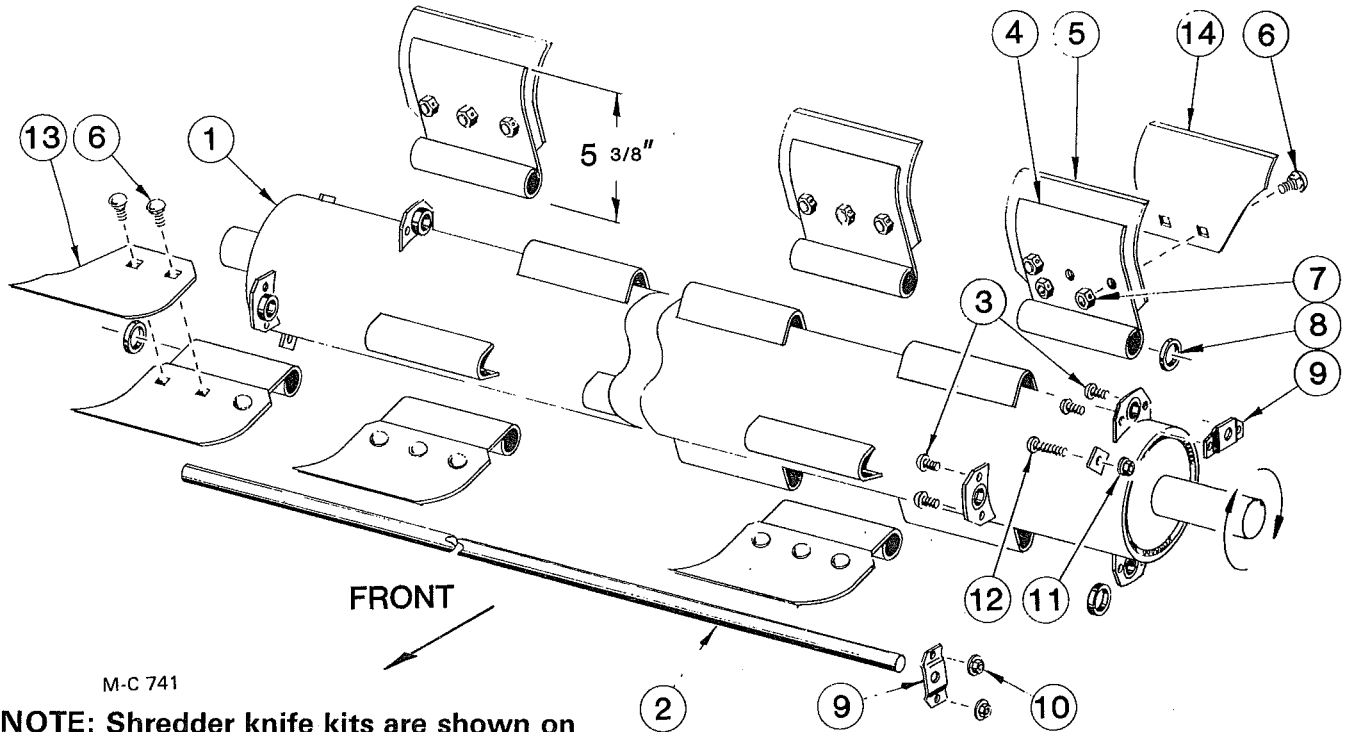

M-C 741

NOTE: Shredder knife kits are shown on page 44.

Model 2408

Complete Assemblies

Right Rotor 111 1069

Left Rotor 111 1070

(Each complete assembly consists of ref. 1 thru 10 in quantities shown. Wipers, ref. 11 and 12 and end knives, ref. 13 and 14 must be ordered separately).

Ref.	Part No.	Qty.	Description
1	111 0188	1	Balanced Rotor Weldment
2	111 8980	4	Rotor Hanger Bar
3	000 8134	16	3/8-16 x 3/4" Truss Hd. Screw
4	111 5200	40	Wide Knife Hanger
5	001 5208	40	(HD) Wide Knife
6	001 8131	120	3/8-16 x 7/8" Knife Carriage Bolt - Grade 8 (Special)
7	001 8149	120	3/8-16 Two Way Locknut
8	--- 6524	8	Knife Spacer
9	001 2000	8	End Locator Bracket
10	000 8168	16	3/8-16 Flanged Locknut
11	000 8168	4	3/8-16 Flanged Locknut
12	000 8125	4	3/8-16 x 1 1/2" Carriage Bolt
13	001 5212	2	End Knife - Right
14	001 5211	2	End Knife - Left

Gear Box Assembly 091 6608 Model 144 & 180

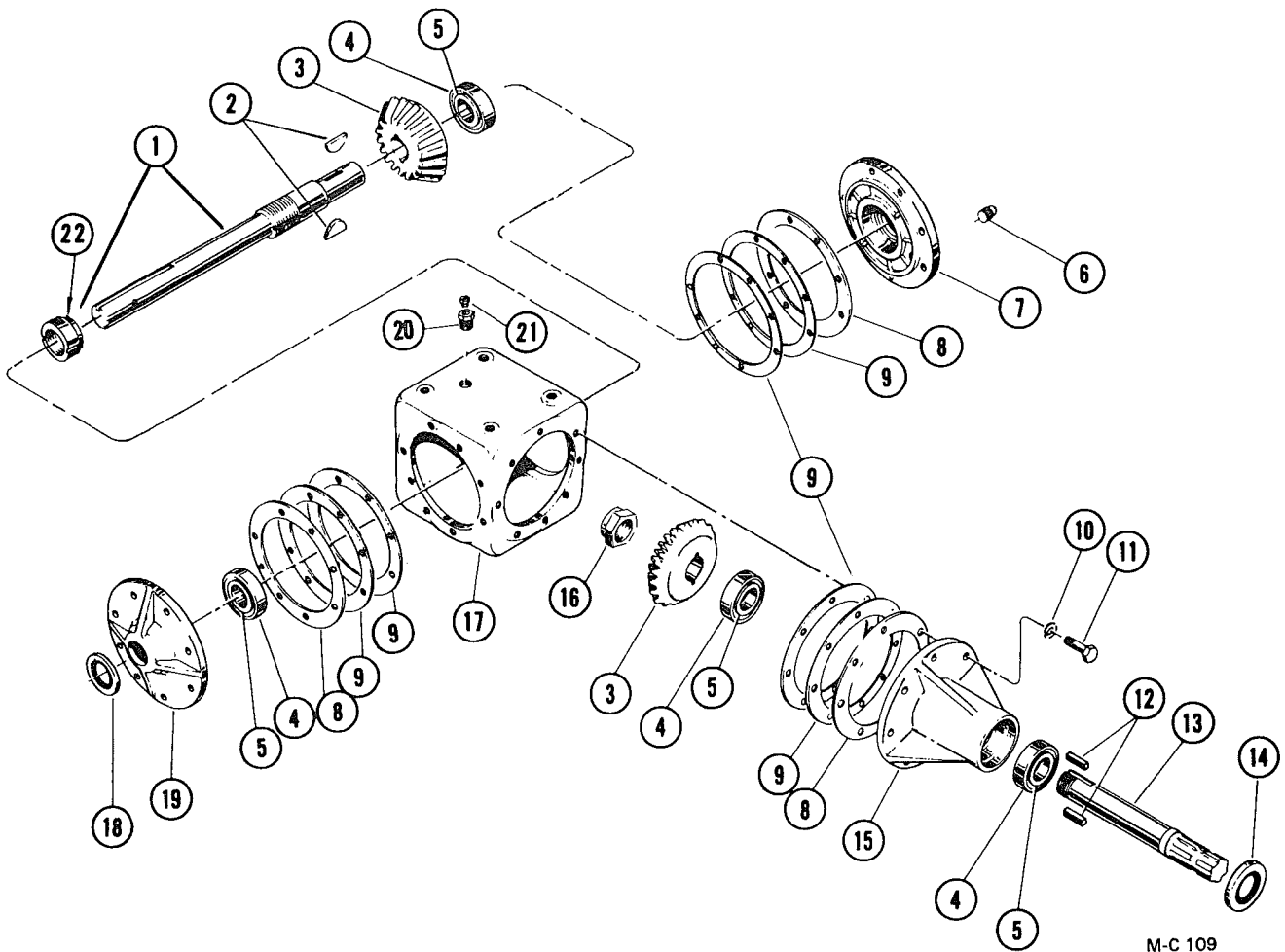

M-C 109

Ref.	Part No.	Qty.	Description	Ref.	Part No.	Qty.	Description
1	092 6621	1	Output Shaft w/Stake Nut	12	001 8969	2	Key $\frac{3}{8}$ x $\frac{3}{8}$ x $1\frac{3}{8}$ " (Hard)
2	001 8988	2	Woodruff Key $\frac{3}{8}$ x $1\frac{1}{2}$ " (Hard)	13	002 6638	1	Input Shaft
3	002 6500	2	Bevel Gear	14	002 6639	1	Grease Seal (Input Shaft)
4	002 6010	4	Bearing Cup	15	002 7656	1	Hub (Includes 2 of ref. 4)
5	002 6011	4	Bearing Cone	16	002 6668	1	Stake Nut (Input Shaft)
6	002 8000	1	Oil Level Plug	17	002 7654	1	Gear Box Housing
7	002 7655	1	Cover, Solid (Includes 1 of ref. 4)	18	002 6667	1	Grease Seal (Output Shaft)
8	002 6636	AR	Shim .005" Thick	19	002 7657	1	Cover, Output Shaft (Includes 1 of ref. 4 & 1 of ref. 18)
9	092 6609	3	Gasket - $\frac{1}{32}$ " Thick	20	002 6678	1	Reducing Bushing - $\frac{3}{8}$ " to $\frac{1}{8}$ " NPT
10	000 8180	24	$\frac{1}{2}$ " Lockwasher	21	002 6677	1	Gear Box Vent - $\frac{1}{8}$ " NPT
11	131 8163	24	$\frac{1}{2}$ -13 x $1\frac{1}{4}$ " Hex-Hd Capscrew - Grade 5, w/NY Patch	22	112 8252	1	Stake Nut (Output Shaft)

Gear Box Assembly 111 6611 Model 2408

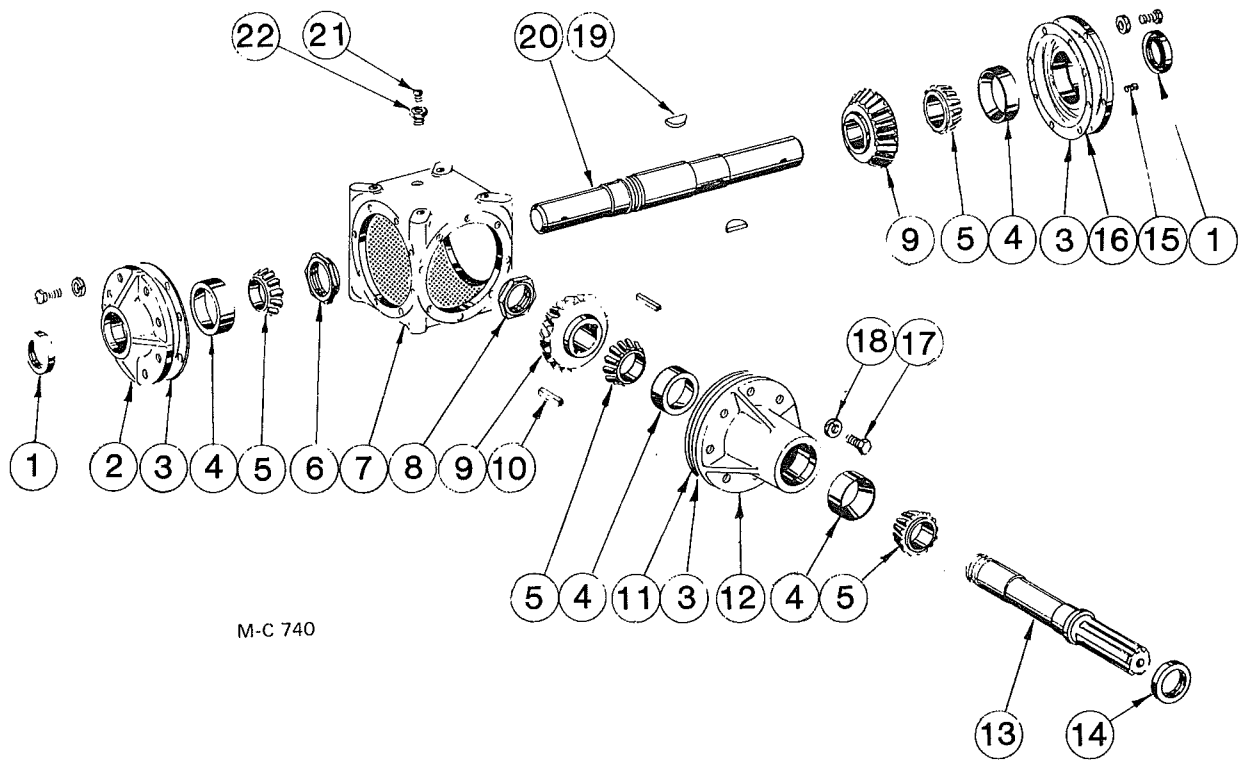

Ref.	Part No.	Qty.	Description	Ref.	Part No.	Qty.	Description
1	002 6667	2	Grease Seal (Output Shaft)	13	002 6638	1	Input Shaft
2	002 7657	1	Cover - Output Shaft Right (Incl. 1 of ref. 1 & 4)	14	002 6639	1	Grease Seal (Input Shaft)
3	092 6609	3	Gasket - 1/32" Thick	15	002 8000	1	Oil Level Plug
4	002 6010	4	Bearing Cup	16	112 7658	1	Cover - Output Shaft Left (Incl. 1 of ref. 1 & 4)
5	002 6011	4	Bearing Cone	17	131 8163	24	1/2-13 x 1 1/4" Hex-Hd. Capscrew - Grd. 5 w/NY Patch
6	112 8252	1	Stake Nut (Output Shaft)	18	000 8180	24	1/2" Lockwasher
7	002 7654	1	Gear Box Housing	19	001 8988	2	Woodruff Key 3/8" x 1 1/2" (Hard)
8	002 6668	1	Stake Nut (Input Shaft)	20	112 6600	1	Output Shaft
9	002 6500	2	Bevel Gear	21	002 6677	1	Gear Box Vent - 1/8" NPT
10	001 8969	2	Key 3/8" x 1 3/8" (Hard)	22	002 6678	1	Reducing Bushing - 3/8" to 1/8" NPT
11	002 6636	AR	Shim .005" Thick				
12	002 7656	1	Hub (Incl. 2 of ref. 4)				

Knife Kits (See Note 1)

Model Number	Kit Part No.	Qty. to Order	Kit Consists of		
			Qty.	Part No.	Description
144	092 9012		48	001 5208	H.D. Wide Knife
			2	001 5211	Left End Knife
			2	001 5212	Right End Knife
180	112 9019	1	60	001 5208	H.D. Wide Knife
			2	001 5211	Left End Knife
			2	001 5212	Right End Knife
2408	112 9026	1 (See Note 2)	80	001 5208	H.D. Wide Knife
			4	001 5211	Left End Knife
			4	001 5212	Right End Knife

NOTE 1: Carriage bolts 001 8131 and Locknuts 001 8149 to assemble knives to knife hangers are not included with knife kits. They must be ordered separately.

NOTE 2: One kit contains sufficient quantities of wide knives and end knives for both rotors.

003 5200

Special Hard Surfaced Cutting Edge Wide Knife. This knife may be substituted for 001 5208 knife for longer knife life on Shredders that are used in non-rocky areas.

If substitution is made, it must be made as a complete set. It is **not** recommended for use on Shredders that operate in rocky fields. The hardening process causes the cutting edge to become brittle, which will have a tendency to chip and break when it comes in contact with a hard surface. These knives are not listed in any kit and will have to be ordered in specific quantities needed.

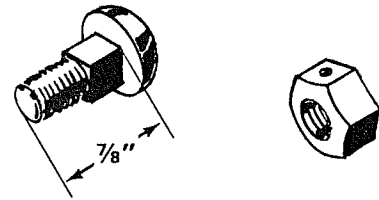
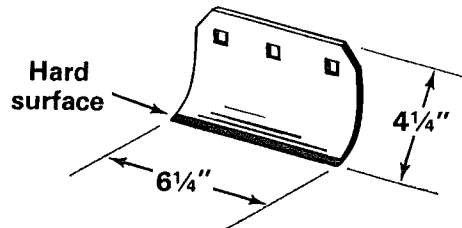

Special Carriage Bolt Part No. 001 8131 ($\frac{3}{8}$ -16 x $\frac{7}{8}$ " Grade 8)

Special 2-Way Locknut Part No. 001 8149

These special carriage bolts and nuts are used on Model 144, 180 and 2408 Shredders. It is recommended that they be replaced whenever a wide knife or wide knife hanger is replaced.

Belt Idler Push Rod and Spring

(There are two of ref. 2 thru 9 on Model 2408)

Ref.	Part No.	Qty.	Description
1	111 0117	1	144, 180 & 2408 Axle Mount - Right
	111 0182	1	2408 - Axle Mount - Left
2	111 0144	1	Spring Spacer
3	141 8979	1	Spring
4	111 0127	1	Spring Retainer
5	111 5717	1	Idler Push Rod
6	128 8164	1	$\frac{1}{2}$ -13 Two Way Lock Nut
7	091 8231	1	1" - 8 Hex Nut
8	001 8291	1	1" - 8 Hex Jam Nut
9	128 8166	1	$\frac{1}{2}$ -13 x 2 $\frac{1}{2}$ " Hex-Hd. Capscrew - Grade 5

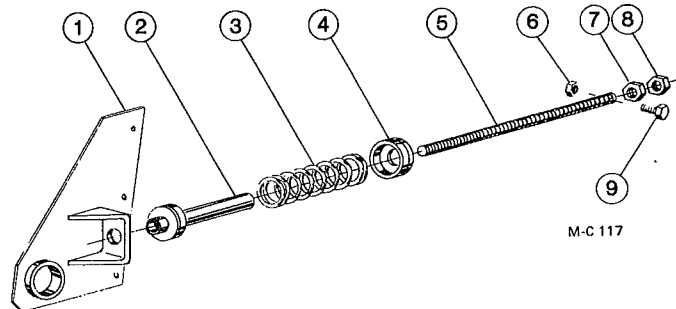

Belt Idler Assembly

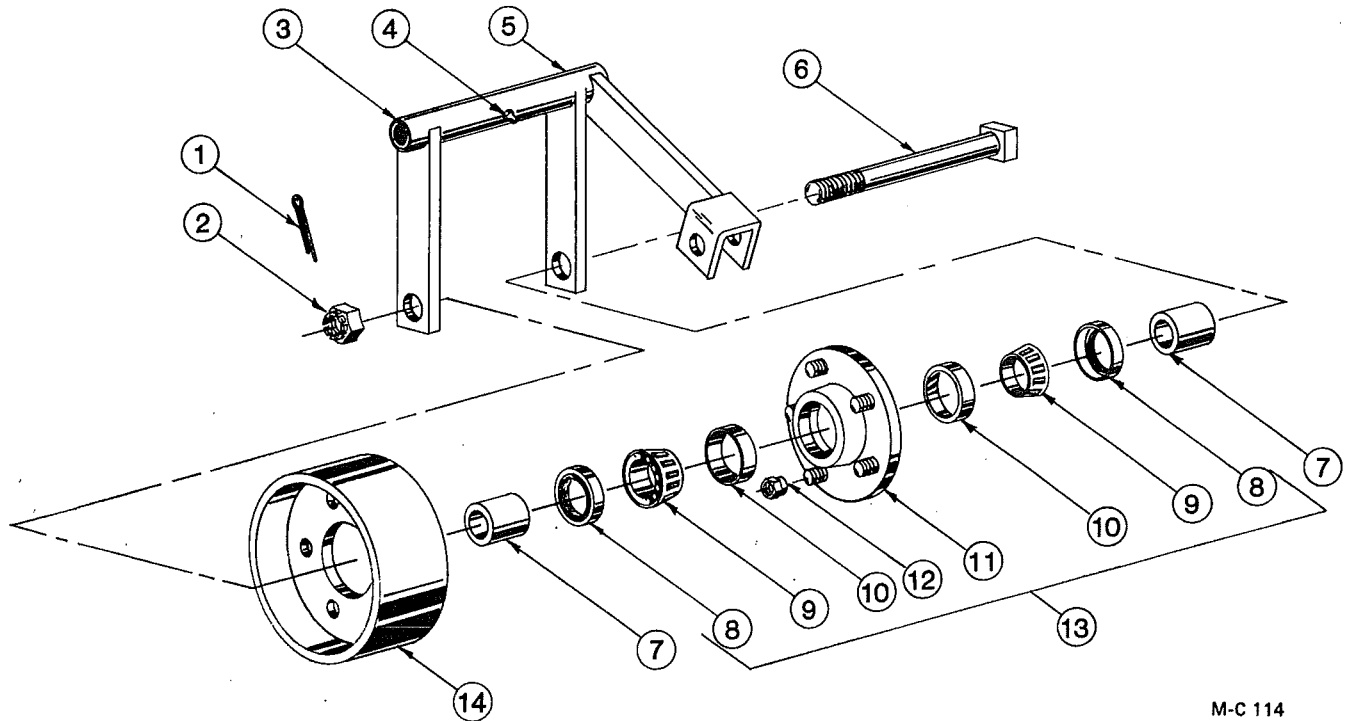

M-C 114

111 1028 Model 144, 180 and Right Side of 2408

111 1073 Model 2408 - Left Side
(Both assemblies are the same except for ref. 5)

Ref.	Part No.	Qty.	Description	Ref.	Part No.	Qty.	Description
1	000 8255	1	1/4" x 2" Cotter Pin	8	112 6000	2	Seal
2	111 8252	1	1 3/8-12 Castle Nut	9	112 6002	2	Bearing Cone
3	128 6017	2	Bronze Bushing	10	112 6001	2	Bearing Cup
4	001 6604	1	90° Zerk Fitting - 1/8"	11	112 8999	1	5 Bolt Hub Ass'y. (Incl. 2 of ref. 10 & 5 studs)
5	111 1029	1	144, 180 & 2408-Idler Rocker Arm-Right (Incl. 2 of ref. 3)	12	001 8989	5	1/2-20 NF Lug Nut 45°
	111 1074	1	2408-Idler Rocker Arm-Left (Incl. 2 of ref. 3)	13	111 8986	1	5 Bolt Hub Ass'y. (Incl. ref. 8 thru 12 in quantities shown)
6	111 0145	1	Idler Bolt 1 3/8" x 7"	14	111 5710	1	Idler Pulley
7	081 5603	2	Idler Hub Spacer				

1000 RPM Tractor Power Take-Off Shaft 111 6610

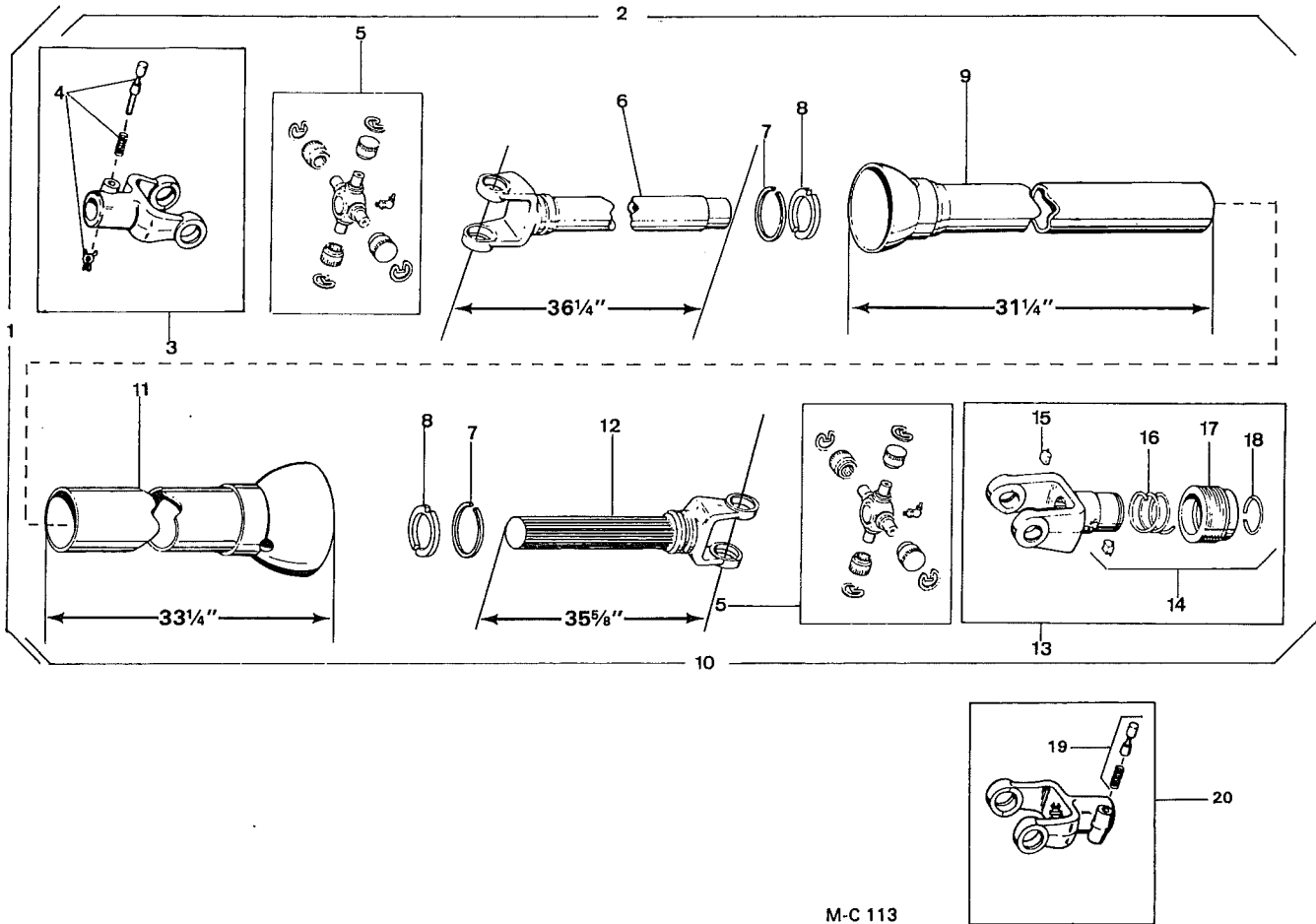

M-C 113

Ref.	Part No.	Qty.	Description
1	111 6610	1	PTO Shaft Complete (1000 RPM)
2	112 6649	1	PTO Shaft (Shredder Half)
3	002 6686	1	Q.D. Yoke Ass'y. 1 $\frac{3}{4}$ " -6B Spline
4	002 6684	1	Saf-T-Pin, Spring & "X" Washer
5	002 6633	2	Universal Joint Repair Kit
6	142 6641	1	Yoke & Tube
7	092 6692	2	Nylon Bearing Retainer
8	092 6693	2	Nylon Bearing
9	142 6602	1	Male Guard Tube
10	142 6612	1	PTO Shaft (Tractor Half)

Ref.	Part No.	Qty.	Description
11	142 6613	1	Female Guard Tube
12	142 6614	1	Yoke & Shaft
13	002 6674	1	Slide Lock Yoke Ass'y. 1 $\frac{3}{8}$ " - 21 Spline
14	082 6612	1	Slide Lock Repair Kit
15	002 6632	2	Slide Lock Pawl
16	002 6630	1	Slide Lock Spring
17	002 6631	1	Slide Lock Collar
18	002 6655	1	Slide Lock Retaining Ring
19	142 6648	1	Saf-T-Pin & Spring Kit 1 $\frac{3}{4}$ " - 20 Spline
20	143 6600	1	Yoke Ass'y. 1 $\frac{3}{4}$ " - 20 Spline

Wheel Mount and Hub Assembly

NOTE: There are four wheel mount assemblies on the Shredder. Quantities shown are for one assembly.

Ref.	Part No.	Qty.	Description
—	111 1041	1	144 & 180 -Wheel Mount Ass'y. w/Clamp (Incl. ref. 1 thru 17)
—	111 1066	1	144 & 180 -Wheel Mount Ass'y. (Incl. ref. 1 thru 13)
—	111 1082	1	2408 -Wheel Mount Ass'y. w/Clamp (Incl. ref. 1 thru 17)
—	111 1083	1	2408 -Wheel Mount Ass'y. (Incl. ref. 1 thru 13)
1	001 8996	1	Hub Cap
2	001 8252	1	Cotter Pin 1/8" x 1"
3	001 8253	1	Spindle Nut
4	001 8254	1	Spindle Washer
5	001 6000	1	Bearing Cone - Outer
6	002 6000	1	Bearing Cup - Outer
7	001 8989	5	144 & 180 -1/2-20 NF Lug Nut - 45°
	090 8988	5	2408 -1/2-20 NF Lug Nut-60°
8	001 8992	1	Wheel Hub Ass'y. - 5 Bolt (Incl. ref. 6, 8A and 9)
8A	002 8152	5	1/2-20 x 1 1/2" Stud

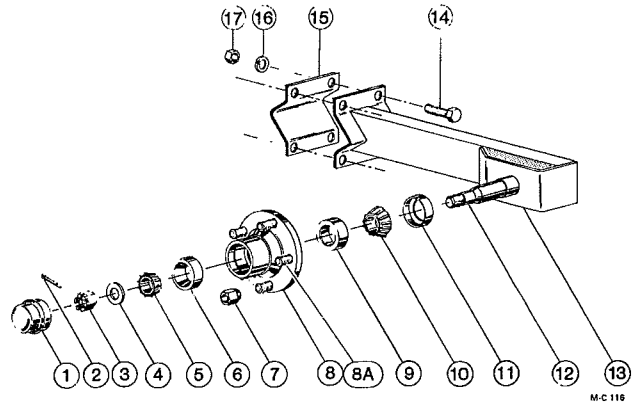

Ref.	Part No.	Qty.	Description
9	002 6001	1	Bearing Cup (Inner)
10	001 6001	1	Bearing Cone (Inner)
11	001 8991	1	Seal
12	001 8990	1	Spindle Only (Must be welded in place)
13	111 0130	1	Wheel Mount w/Spindle (Incl. ref. 15)
14	128 8196	4	3/4-10 x 2 1/2" Hex-Hd. Capscrew Grade 5
15	111 3590	1	Wheel Mount Clamp
16	000 8182	4	3/4" Lockwasher
17	000 8165	4	3/4-10 Hex Nut

Output Shaft Universal Joint

Ref.	Part No.	Qty.	Description
1	111 8988	—	Output Shaft Universal Joint Ass'y.
2	002 6687	2	End Yoke 1 3/4" Bore
3	002 6688	1	Universal Joint Repair Kit

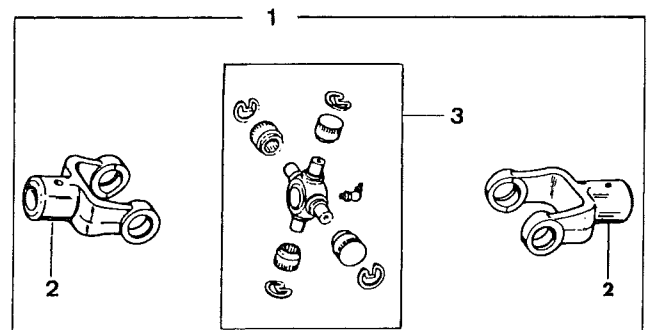

M-C 110

End Tow System (Optional)

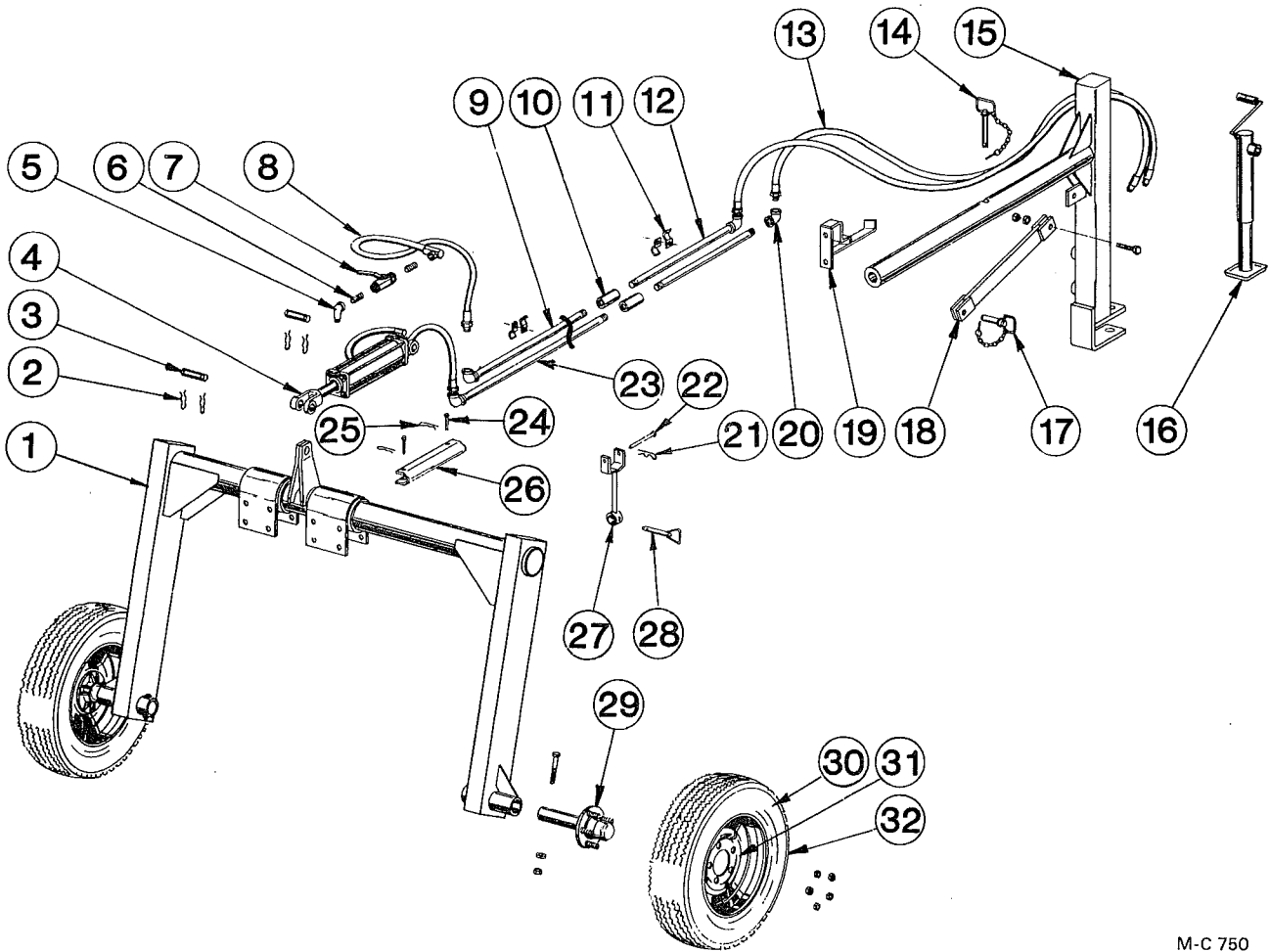

M-C 750

Ref.	Part No.	Qty.	Description	Ref.	Part No.	Qty.	Description
1	111 0178	1	Transport Weldment	14	113 8160	1	Transport Lock Arm Pin
	001 8279	16	5/8-11 x 2" Hex-Hd. Capscrew - Grade 5	15	111 0176	1	End Transport Weldment
	000 8176	16	5/8" Flatwasher	16	113 8998	1	End Tow Pole Jack
	000 8181	16	5/8" Lockwasher	17	113 8170	1	Transport Clevis Pin
	000 8164	16	5/8-11 Hex Nut	18	113 0020	1	Pole Brace
2	042 7002	4	Hair Pin Clip		128 8166	1	1/2-13 x 2 1/2" Hex-Hd. Capscrew - Grade 5
3	042 7001	2	Clevis Pin - 1" x 3 3/4"		000 8175	1	1/2" Flatwasher
4	111 7000	1	Hyd. Cylinder - 3 1/2" x 8"		128 8164	1	1/2-13 Two Way Locknut
5	121 8048	1	Street Elbow 1/2" x 90° Std.	19	113 0019	1	Transport Field Support
6	121 8094	2	Nipple - 1/2" x 1/2" Exhvy.		000 8278	2	1/2-13 x 1 3/4" Hex-Hd. Capscrew - Grade 5
7	111 7001	1	Locking Valve		000 8180	2	1/2" Lockwasher
8	113 8400	2	Hyd. Hose 5' w/90° Swivel		000 8163	2	1/2-13 Locknut
9	127 8058	1	Nipple - 1/2" x 77" Exhvy.	20	125 8073	4	Elbow - 1/2" x 90° Std.
10	128 8017	2	Coupling - 1/2" Exhvy.	21	113 8252	1	Hair Cotter Pin - 5/32"
11	121 6904	4	Pipe Strap	22	113 8130	1	PTO Hanger Pin
	000 8100	2	1/4-20 x 3/4" Hex-Hd. Capscrew	23	127 8057	1	Nipple 1/2" x 81" Exhvy.
	000 8167	2	1/4-20 Flanged Locknut	24	113 8102	2	Ram Stop Pin
12	121 8015	2	Nipple - 1/2" x 30" Exhvy.	25	113 8251	2	Hair Cotter Pin - 3/32"
13	113 8401	2	Hyd. Hose - 7'	26	111 4802	1	Ram Stop
				27	111 0180	1	PTO Support

Ref.	Part No.	Qty.	Description
28	113 8131	1	PTO Hanger Base Pin
29	113 1007	2	Transport Axle Ass'y. (See page 49)
	000 8151	2	5/8-11 x 3 1/2" Hex-Hd. Capscrew - Grade 5
	000 8181	2	5/8" Lockwasher
	000 8164	2	5/8-11 Hex Nut
30	092 8983	2	7.50 x 10E-10 Ply Tire & Tube
31	092 8984	2	Wheel - 6" Wide x 10" Dia.
32	091 8981	2	Flotation Tire Complete (Incl. 1 ea. of ref. 30 & 31)

Transport Axle Assembly - 113 1007

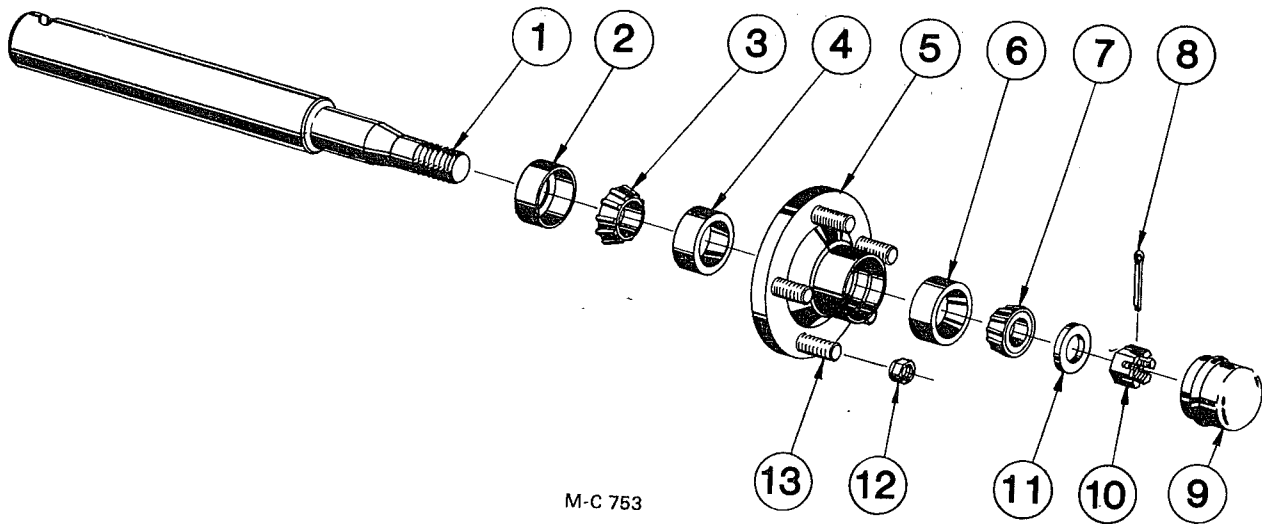

NOTE: There are two axle assemblies on the end tow system. Quantities shown are for one assembly.

Ref.	Part No.	Qty.	Description	Ref.	Part No.	Qty.	Description
—	113 1007	1	Transport Axle Ass'y. (Incl. ref. 1 thru 13)	6	002 6000	1	Bearing Cup - Outer
1	111 5065	1	Spindle	7	001 6000	1	Bearing Cone - Outer
2	001 8991	1	Seal	8	001 8252	1	Cotter Pin 1/8" x 1"
3	001 6001	1	Bearing Cone - Inner	9	001 8996	1	Hub Cap
4	002 6001	1	Bearing Cup - Inner	10	001 8253	1	Spindle Nut
5	001 8992	1	Wheel Hub Ass'y. - 5 Bolt (Incl. ref. 4, 6 & 13)	11	001 8254	1	Spindle Washer
				12	090 8988	5	1/2-20 Lug Nut - 60°
				13	002 8152	5	1/2-20 x 1 1/2" Stud

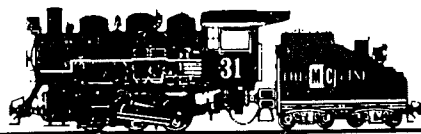
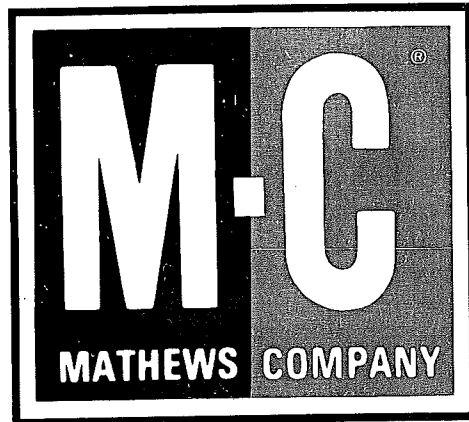

Iron Horse Quality