

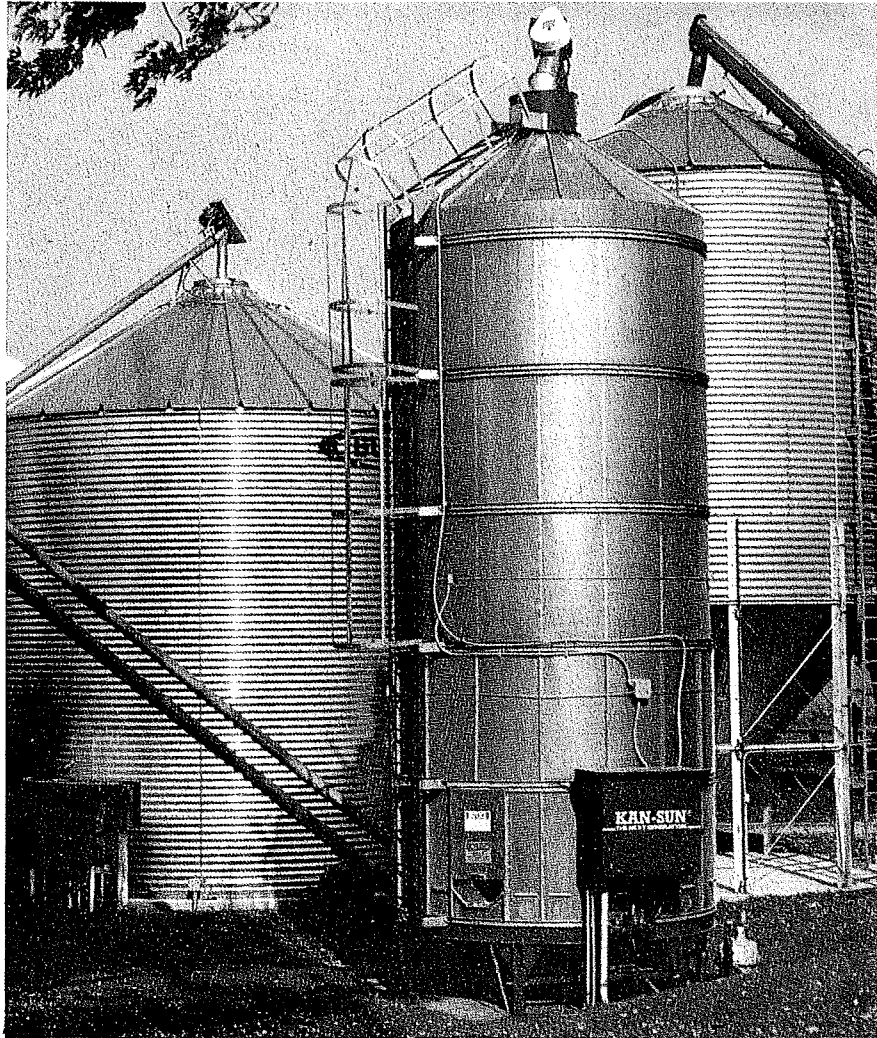

# KAN-SUN®

== THE NEXT GENERATION™ ==



MODEL 10420, 10530, 10630, & 10730

## OPERATOR'S and PARTS MANUAL

Form No. K311, April 1994

(Replaces all previous M-C Kan-Sun Manuals for years 1992 through 1994)

**Mathews Company** / 500 Industrial Ave., Crystal Lake, IL 60012, U.S.A.  
815/459-2210 FAX: 815/459-5889

# C O N T E N T S

<b>INTRODUCTION</b>	<b>PAGE</b>
To the Owner-Operator . . . . .	1
Safety Precautions . . . . .	1
Warranty Registration . . . . .	1
Model and Serial Number Location . . . . .	1
Capscrew Grade Identification . . . . .	2
Metric (SI) Measurements . . . . .	2
 <b>DIMENSIONAL DRAWINGS</b>	
Dryer . . . . .	4 & 53
Dryer Base . . . . .	53
 <b>WIRING DIAGRAMS . . . . . (see foldouts at the back of the manual)</b>	
 <b>SET-UP INSTRUCTIONS</b>	
General . . . . .	3
Permanent Installation . . . . .	3
Assembly . . . . .	6
Kan-Sun Ladder Installation . . . . .	3-6
Erection . . . . .	7
Anchoring the Dryer . . . . .	8
Gas Supply and Connections . . . . .	8
LP Fuel . . . . .	8
Natural Gas . . . . .	8
Electric Power Supply . . . . .	9
Recommended Electrical Specifications . . . . .	10
Suggested Wiring of Auxiliary Equipment . . . . .	11
Fan Motor Current Data . . . . .	11
Filling Equipment (Customer Supplied) . . . . .	12
 <b>CONTROL PANEL LIGHTS, SWITCHES AND METERS</b>	
Control Panel Lights . . . . .	12
Malfunction Lights . . . . .	12
Status Lights . . . . .	12
Start-Up Run Switch . . . . .	12
Fans Switch . . . . .	12
Burner Switch . . . . .	12
Fill Switch . . . . .	12
Grain Temperature . . . . .	12
Manual Speed Control Potentiometer . . . . .	12
Low Bin Lamp . . . . .	12
Discharge System Start/Run/Off Switch . . . . .	14
Moisture-Matic®II Automatic/Manual Switch . . . . .	14
Auto Set Point Potentiometer . . . . .	14
Total Hours Meter . . . . .	14
Plenum Temperature Meter . . . . .	14
Grain Temperature Meter . . . . .	14
Discharge Speed Meter . . . . .	14
Flame Monitor No. 1 Reset . . . . .	14
Flame Monitor No. 2 Reset . . . . .	14
Flame Monitor Resets Closed Lamp . . . . .	14
Control Circuit Lamp . . . . .	14
Hot-Cold Switch . . . . .	14
Balance Lamps . . . . .	14

<b>DRYING INFORMATION</b>	<b>PAGE</b>
Moisture-Matic®II . . . . .	14
Drying Rate . . . . .	14
Drying Temperature Limits. . . . .	15
Cooling . . . . .	15
Drying in General . . . . .	15
Corn . . . . .	15
Soybeans. . . . .	15
Wheat . . . . .	15
 <b>INITIAL START-UP INSTRUCTIONS</b>	
General . . . . .	16
Filling the Dryer . . . . .	17
Setting the Low Grain Timer . . . . .	17
Starting the Burners. . . . .	17
Setting Burner Operating Temperatures . . . . .	18
Operation of the Discharge System with Moisture-Matic®II . . . . .	18
Rear Discharge Overload Door . . . . .	19
Manual Control of Moisture Content. . . . .	19
Moisture-Matic®II Automatic Moisture Control . . . . .	20
 <b>OPERATING INSTRUCTIONS</b>	
Drying Grain with Moisture-Matic®II Moisture Control . . . . .	20
Fill Equipment . . . . .	20
Low Grain Timer Operation. . . . .	20
Dryer Shutdown. . . . .	21
Second or Subsequent Day Start-Up . . . . .	21
Emptying the Dryer . . . . .	21
Off Season Storage . . . . .	21
 <b>SEASONAL MAINTENANCE</b>	
Maintenance Inside Machine for Start-Up. . . . .	21
Maintenance Outside Machine. . . . .	21
 <b>LUBRICATION. . . . .</b>	
SCR Board . . . . .	22
SCR Board Trim Pot Adjustment Procedure . . . . .	23
 <b>TROUBLESHOOTING. . . . .</b>	
 <b>PARTS LIST</b>	
Auger-Sweep . . . . .	29
Cooling Section . . . . .	30
Heat Section . . . . .	31
Crawl Door. . . . .	32
Heat Floor . . . . .	33
Cooling Floor. . . . .	34
3 HP DC Motor Mount . . . . .	35
Fan Assembly. . . . .	36
Burner. . . . .	37
LP/NG Plumbing Assembly . . . . .	38-39
Control Box and Panel Assembly. . . . .	40-41
Electrical Components. . . . .	42
Thermistors . . . . .	43
Thermistor Chart . . . . .	44

	<b>PAGE</b>
Phase Converter . . . . .	45
Roof and Peak Section . . . . .	46
Grain Receiving Top Assembly . . . . .	47
Ladder Assembly. . . . .	48
Electric Components, 460 Volt . . . . .	49
Phase Converter Wiring Details - 230 VAC - 1PH, 10 or 15 HP . . . . .	50
Motor-Transformer Wiring Details, 460 VAC-3PH, 10 or 15 HP. . . . .	50
230 Volt Motor Wiring . . . . .	51
Kan-Sun Moisture-Matic®II (Deadband Adjustment). . . . .	52
10' Dryer Dimensions . . . . .	53
Wiring Schematic (Kan-Sun) . . . . .	54
Wiring Diagram (Kan-Sun). . . . .	55

### ILLUSTRATIONS USED IN TEXT

Figure 1	Model and Serial Number Location . . . . .	1
Figure 3a	Ladder Bracket and Cage Assembly. . . . .	3
Figure 3b	Ladder Mounting Holes . . . . .	5
Figure 3c	Ladder Assembly. . . . .	6
Figure 2	Foundation Layout and Anchoring Information . . . . .	4
Figure 4	Placement of Hold Down Brackets for Lifting . . . . .	7
Figure 5	Control Panel . . . . .	13
Figure 6	LP Piping (Inlet and Main Hand) . . . . .	16
Figure 7	High Limit and Low Temperature Thermostats . . . . .	16
Figure 8	Control Cabinet (Inside). . . . .	17
Figure 9	LP Piping - Modulating Valve "T" Handle and Hand Valve . . . . .	18
Figure 10	Rear Discharge Overload Door . . . . .	19
Figure 11	Control Cabinet (Inside). . . . .	20
Figure 12	500 Series SCR Board . . . . .	22



# INTRODUCTION

## TO THE OWNER-OPERATOR

This manual provides information on set-up, initial start-up, operation, shutdown, and maintenance as well as a parts breakdown for Kan-Sun Models 10420, 10530, 10630, 10730 Grain Dryers enabling owners and operators to keep their grain dryers operating at peak efficiency.

Before operating your Grain Dryer read the Start-Up and Operating Instructions. Become familiar with the controls, adjustments and settings to accomplish efficient operation.

To keep the dryer operating at peak efficiency it is suggested that it be cleaned and lubricated, adjust belt tension, and each year prior to the dryer season test the ignition system and unloading system.

Refer to "Pre-Season Check" in the Maintenance section. The pre-season check can be made when the dryer is empty and any necessary repairs or adjustments can be made so the dryer is ready to operate before the drying season.

## SAFETY PRECAUTIONS



This symbol is used to call your attention to instructions concerning your personal safety. Be sure to observe and follow these instructions.

A safe operator is the best insurance against accidents. The precautions listed below must be observed at all times.

- Do not allow children or bystanders to be near the Grain Dryer or grain handling machinery while it is operating.
- Do not operate the Grain Dryer without all safety shields in place and secure.

**NOTE: To provide clear illustrations some of the covers, guards and shields were removed.**

## WARRANTY REGISTRATION

It is important to send in your warranty registration sheet as soon as your new Grain Dryer is delivered. The sheet validates your grain dryer warranty, and is also our way of knowing who has purchased M-C equipment so we can keep in touch with you.



Figure 1

## MODEL AND SERIAL NUMBER LOCATION

The model and serial number of your Grain Dryer are stamped on a plate located on the triangular support leg next to the control panel. For future reference, record the model and serial number in the blank spaces in Figure 1.





## CAPSCREW GRADE IDENTIFICATION

There are four grades of hex-head capscrews. Grade 1 and 2 are common capscrews, grade 5 and grade 8 are used when greater strength is required. Each grade can be identified by

the marking on the head of the capscrew, see chart.

When servicing the Dryer and/or replacing capscrews, be sure to use the correct size and grade.

### CAPSCREW GRADE IDENTIFICATION CHART

S.A.E. Grade	Description	Capscrew Head Marking*
1	WILL HAVE A PLAIN HEAD - NO RADIAL LINES	
2	Low or Medium Carbon Steel Not Heat Treated	
5	WILL HAVE 3 RADIAL LINES Quenched and Tempered Medium Carbon Steel	
8	WILL HAVE 6 RADIAL LINES Quenched and Tempered Special Carbon or Alloy Steel	

\*The center marking identifies the capscrew manufacturer

## Metric (SI) Measurements

### (English Units & Metric (SI) Equivalents)

#### Area

- 1 square inch = 6.4516 square centimeters
- 1 square foot = 0.0929 square meters
- 1 square yard = 0.8361 square meters
- 1 acre = 4047 square meters
- 1 acre = 0.4047 hectare

#### Force

- 1 pound (force) = 4.45 newtons

#### Length

- 1 inch = 25.4 millimeters
- 1 inch = 2.54 centimeters
- 1 foot = 304.8 millimeters
- 1 foot = 30.5 centimeters
- 1 foot = 0.305 meters
- 1 yard = 0.9144 meters
- 1 mile = 1.6093 kilometers

#### Mass

- 1 ounce = 28.35 grams
- 1 pound = 0.454 kilograms
- 1 ton = 907.1848 kilograms

#### Power

- 1 horsepower = 0.7457 kilowatts

#### Pressure

- 1 psi = 6.89 kilopascals
- 1 psi = 0.00689 megapascals
- 1 inch of mercury = 3.377 kilopascals

#### Temperature

- 1 degree Fahrenheit ( $^{\circ}\text{F} - 32$ )  $\div 1.8 = ^{\circ}\text{Celsius}$

#### Torque

- 1 inch pound = 0.113 newton meters
- 1 foot pound = 1.356 newton meters

#### Velocity

- 1 mile per hour = 1.61 kilometers per hour

#### Volume

- 1 bushel = 35.24 liters
- 1 bushel = 0.0352 cubic meters
- 1 pint = 0.4731 liters
- 1 quart = 0.9464 liters
- 1 gallon = 3.7854 liters
- 1 cubic inch = 16.387 cubic centimeters
- 1 cubic foot = 0.0283 cubic meters
- 1 cubic yard = 0.7646 cubic meters

**NOTE:** The Mathews Company reserves the right to incorporate changes in design without obligation to make these changes on units previously sold.

# SET-UP INSTRUCTIONS

## GENERAL

Check to make sure that all the parts and hardware listed on the packing list have been received.

**IMPORTANT:** Inspect for and remove any foreign material (nuts, bolts, tools, parts, etc.) from the hopper, grain columns, unload auger and heat chamber before filling the dryer with grain. Also be sure the heat chamber door is in position and secure. Check to make sure that the fan blade moves freely and has sufficient clearance.

## PERMANENT INSTALLATION

The dryer must be installed on a level concrete foundation designed to carry the weight of the dryer when full of grain (Model 10420 approximately 33,950 lbs., Model 10530 approximately 40,130 lbs., Model 10630 approximately 46,300 lbs., Model 10730 approximately 52,480 lbs.). The foundation must be engineered locally for ground and weather conditions to prevent settling and frost upheaval. (See Figure 2.)

Additional considerations are as follows:

1. Allow for unrestricted air flow around the dryer and a clean supply of intake air.
2. It is recommended that the dryer not be closer than 10 feet to another dryer.
3. Be sure to ground the dryer by embedding an 8 foot rod in the ground.

## ASSEMBLY

**IMPORTANT:** When assembling the dryer, avoid dropping nuts, bolts or parts down the grain columns. If anything is accidentally dropped in, it must be removed before filling the dryer with grain.

### KAN-SUN LADDER INSTALLATION

1. Assemble the ladder and ladder cage on individual sections before bolting the

sections together. The ladder and ladder alignment is determined by counting one divider over from the right side of the control cabinet and then the first set of mounting holes for the left ladder bracket. Leave the top set of ladder mounting brackets loose for use in attaching the ladder from higher sections. (See Figure 3b)

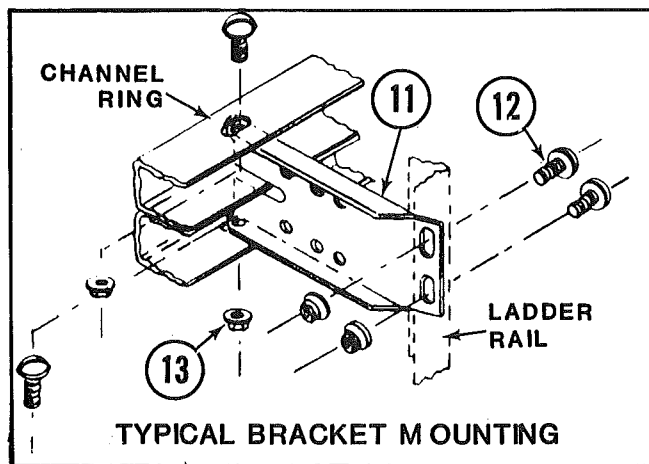
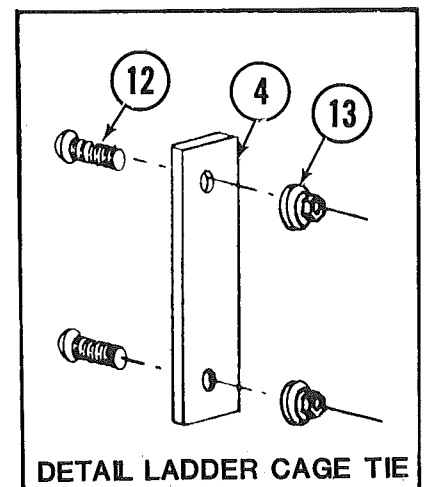

Figure 2a -  
Ladder Bracket  
and  
Cage Assembly

KS1375





# FOUNDATION LAYOUT AND ANCHORING INFORMATION FOR 10420, 10530, & 10630

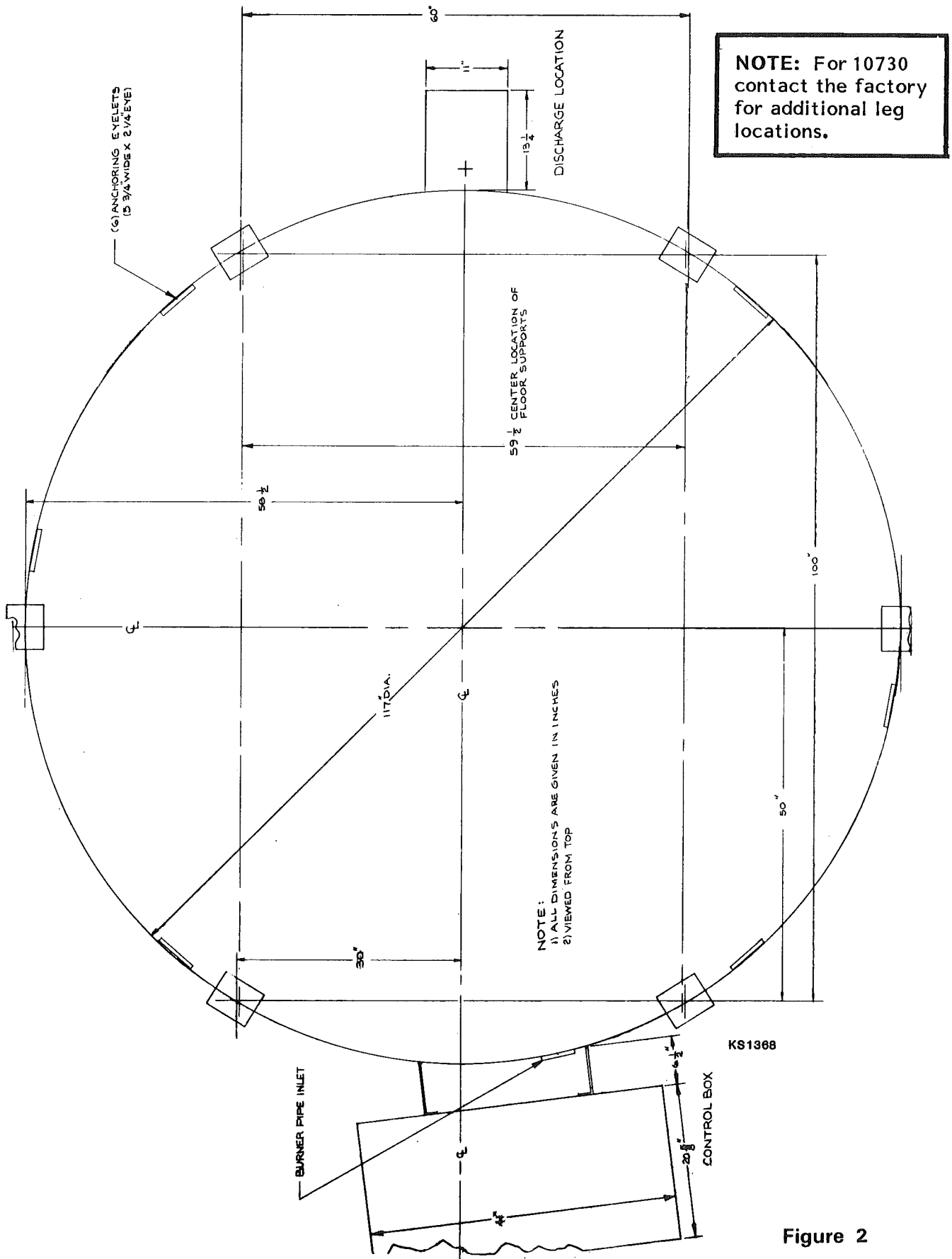

**NOTE:** For 10730 contact the factory for additional leg locations.

**Figure 2**

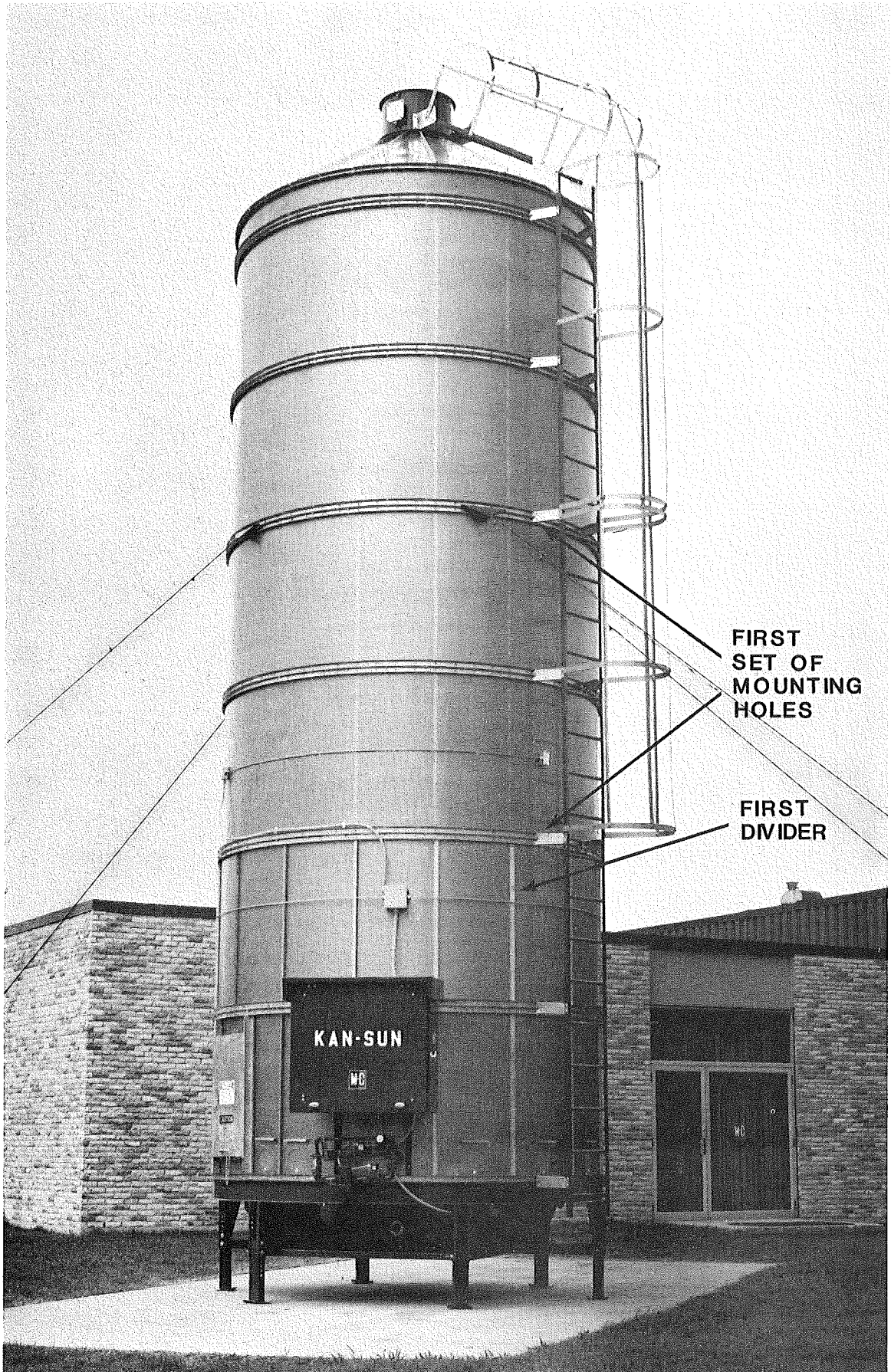

FIRST  
SET OF  
MOUNTING  
HOLES

FIRST  
DIVIDER

Figure 3b - Ladder Mounting Holes

LADDER TO FILL  
MOUNT BRACKET

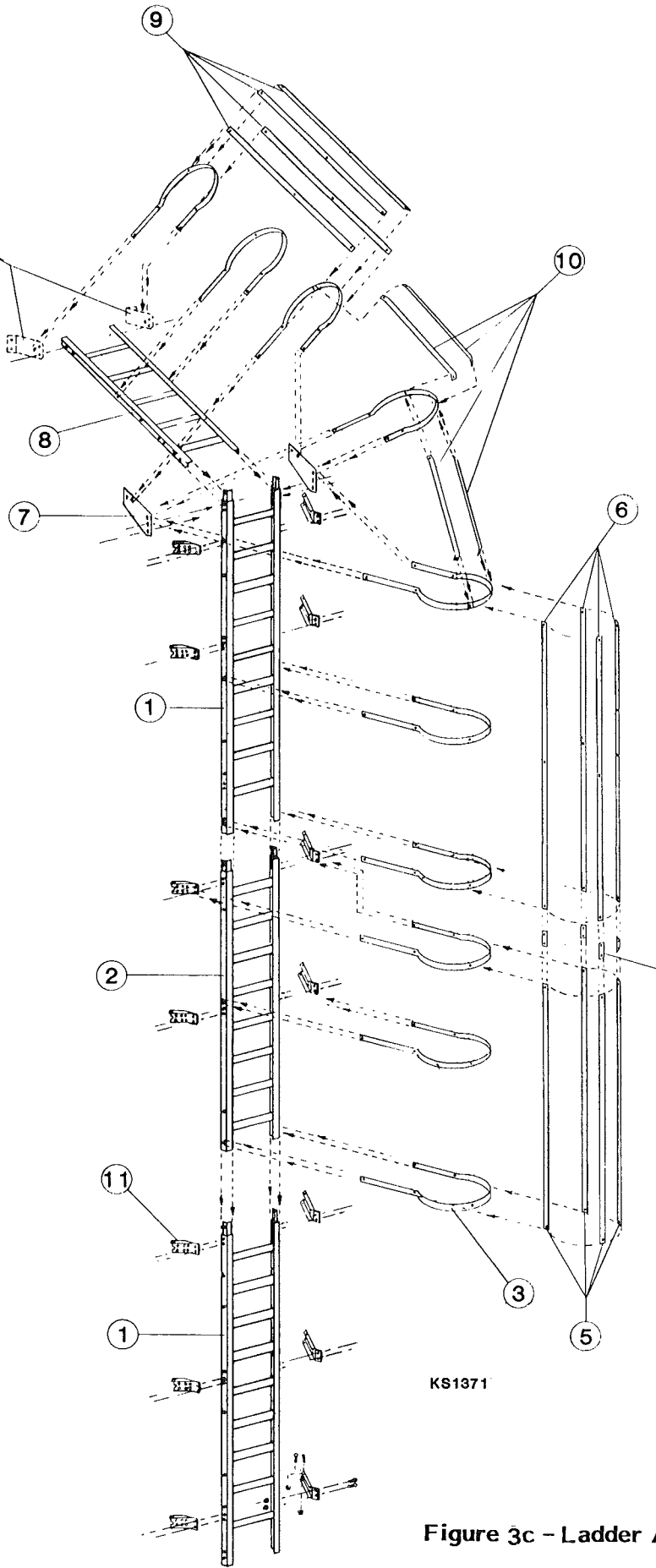

KS1371

Figure 3c - Ladder Assembly

## ERECTION

1. Assemble the dryer sections as follows:
  - A. Start by positioning the base unit using the lifting brackets located beneath the base, in a 4 point lift. Discard the shipping legs and attach the leg extensions to the base weldment aligning the holes. Set the base section into place so the discharge auger is correctly positioned.
  - B. Level the dryer using metal shims as required.

**IMPORTANT:** As sections are mounted, channel splices will align in a 90° rotation so four splices appear around the dryer. Be careful not to damage the channel rings or screens while handling.

- C. When lifting screen sections (maximum 2 sections) only use the three hold down brackets. Bolt them to the bottom inside of the top channel of a one or two section unit locating a bracket at three equally spaced intervals.

**NOTE:** Do not lift more than two sections with the three lifting brackets.

- D. Position the middle section on top of the base section aligning the ladder into the ladder of the base unit. The inside channel splice should align with the splice on outside channel ring of the base unit. (See Figure 3c)
- E. Position the top section (using the U bolt as the lifting point) on top of the middle section aligning the ladder of the top section into the ladder of the middle section. The inside channel splice should align with the splice on the outside channel ring of the section below it. When positioned correctly, all screen seams should line up. (See Figure 3b)
- F. Tighten all bolts.

**WARNING: DO NOT** use hold down brackets to lift the base section.

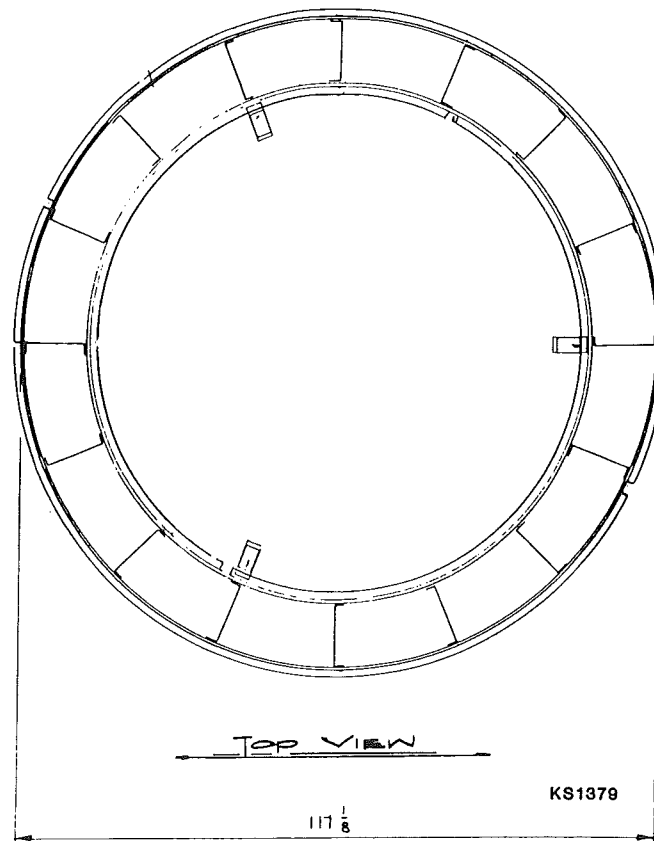

Figure 4 – Placement of Hold Down Brackets for Lifting

## ANCHORING THE DRYER

Immediately after installation, anchor the dryer to the foundation by using turn buckles that can be mounted to the dryer frame and secure it to the foundation. In temporary installations and in areas where blow over may occur due to the wind the dryer should be guy wired. (See Figure 4 and dimensional data at back of manual.

**NOTE:** All anchoring material and cable are to be supplied and installed by the customer.

## GAS SUPPLY AND CONNECTIONS

### LP Fuel

1. The dryer requires liquid propane from the LP tank (not vapor).

**IMPORTANT:** Do not store liquid propane in tanks that have contained anhydrous ammonia. Mixing liquid propane and anhydrous ammonia produces an extremely caustic solution that will damage the dryer controls. It is recommended that only clean LP gas equipment be used.

2. An excess flow valve must be installed on the LP tank. One is furnished with the dryer. The LP tank **MUST BE** equipped for liquid withdrawal. The gas line from the tank to dryer should be ½" Sch 80 pipe or ½" ID Type K copper tubing.
3. Connect the LP gas line from the tank valve to the LP gas inlet at the front (control box side) of the dryer.



**CAUTION:** Before starting the dryer test for any gas leaks. Turn the gas supply on and apply soap water to **ALL** pipe joints and unions, including pipes assembled on the site and those assembled at the factory.

### Natural Gas

1. Consult the gas company for gas supply line size required to the dryer that will provide an adequate volume of gas to meet the dryer BTU/Hr. requirement at the required operating pressure. See Gas Consumption (BTU/Hr.) Chart. The incoming line size should be 1½-2 inches for runs under 200 feet.

**IMPORTANT:** Use type of supply line specified by Local Codes.



**CAUTION:** Before starting the dryer test for any gas leaks. Turn the gas supply on and apply soap water to **ALL** pipe joints and unions, including pipes assembled on the site and those assembled at the factory.

2. Connect the NG line to the NG inlet at the front (control box side) of the dryer on the left side.
3. See Operating Fuel Requirements on page 9 .

## OPERATING FUEL REQUIREMENTS

	NORMAL CONDITIONS 50°F Ambient - 220°F Plenum			
MODEL	10420	10530	10630	10730
BTU/Hr.	3,550,000	4,100,000	4,400,000	4,650,000
G.P.H. (LP Liquid)*	37.4	45.6	48	51.6
C.F.H. (Nat.Gas)**	3550	4100	4400	4650

\*LP Gas - 90,000 BTU's/Gal.

\*\*NG - 1,000 BTU's/Cubic Ft.

LP units have 3/16" orifice, factory installed.  
(1/8" orifice special - see burner parts page.)

Natural gas units are shipped from the factory  
with no orifice.

	ORIFICE	
FUEL	HIGH-TEMP (175 - 240°F)	LOW-TEMP (110 - 175°F)
LP	3/16	1/8
NG	NONE	NONE

## ELECTRIC POWER SUPPLY

Use a power source to the control cabinet that meets all requirements of the local electrical codes. The power source must be adequately fused and have a main disconnect.

All electrical work to be performed by a qualified electrician.

1. See "Recommended Electrical Specifications", page 10, for power and ground lead hook-up. Check for proper fan rotation.

2. Connect bin fill wires from control box to bin fill switch on holding section. Wires are connected to the bin fill switch for fill equipment control. See page 11 for suggested wiring of bin fill and take-away augers.

3. Attach thermistor cable from three-way box on second section to four-way box above control cabinet. Connect individual lead to terminal strips inside four-way thermistor box.

**IMPORTANT:** Check resistance reading of thermistor wires disconnected from Moisture-Matic®II board. Determine that neither wire is shorted to ground and resistance reading is correct for current ambient temperature. See page 44.

## RECOMMENDED ELECTRICAL SPECIFICATIONS

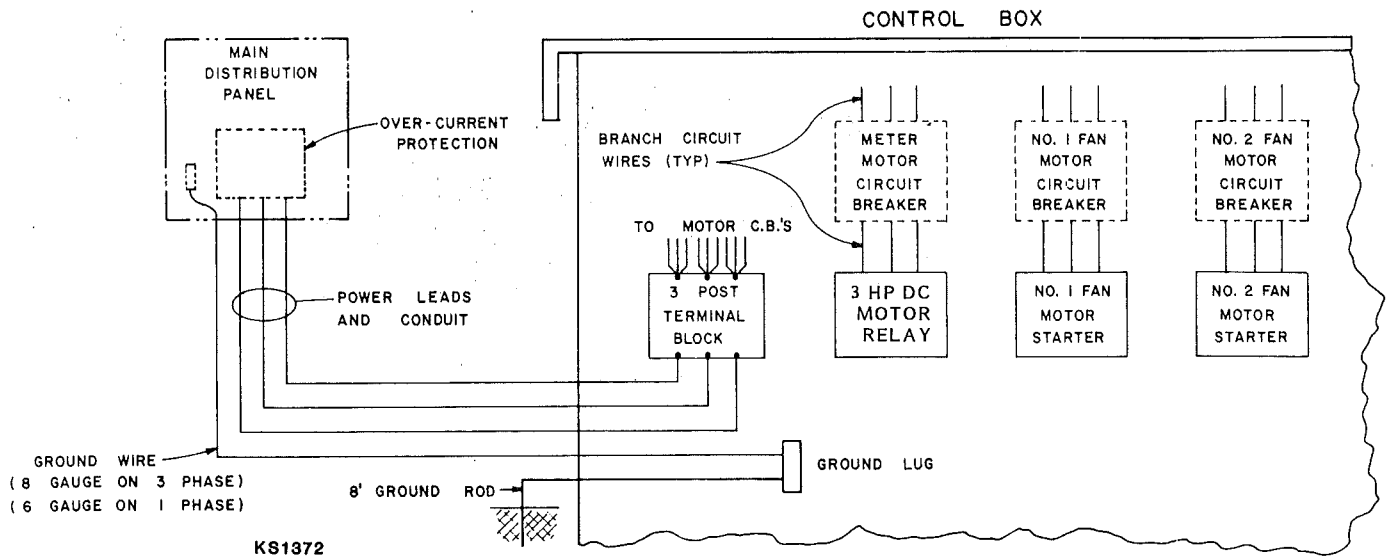

Mathews Company assumes no responsibility that the following recommendations comply with prevailing codes. Recommendations furnished are only an aid for the erector / electrician. All electrical work to meet prevailing codes and be performed by a qualified electrician.

DRYER MODEL	SUPPLY POWER	FULL LOAD AMPS
10420	230	128
10530	VOLT	150
10630	1 $\phi$	150
10730		150
10420	230	86
10530	VOLT	96
10630	3 $\phi$	96
10730		96
10420	460	43
10530	VOLT	48
10630	3 $\phi$	48
10730		48

**NOTE:** Control box motor starters, three post terminal block and ground bar are furnished by Mathews Company. Customer to furnish all other items shown.

## SUGGESTED WIRING OF AUXILIARY EQUIPMENT TYPICAL FILL CIRCUIT

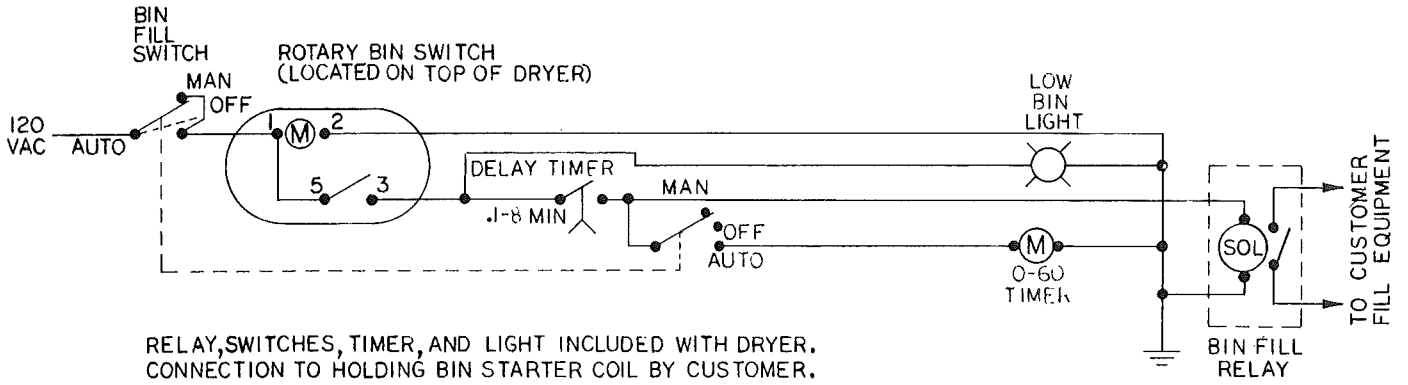

### TYPICAL TAKE AWAY AUGER CIRCUIT

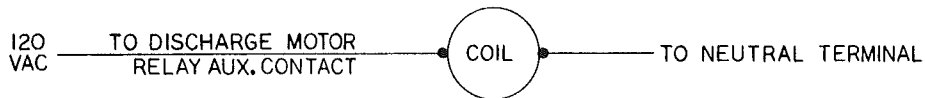

NOTE:  
COMPONENTS FURNISHED BY OWNER  
UNLESS OTHERWISE NOTED.  
USE 18 AWG WIRE SIZE FOR  
CONTROL CIRCUIT.

CUSTOMERS  
TAKE AWAY AUGER  
MOTOR CONTACTOR  
COIL (120 VOLT ONLY)

KS1370

## FAN MOTOR CURRENT DATA

### MOTOR RUNNING CURRENT LOADED (TYPICAL)

LINE No.	1	2	3	4	5	6
10 HP	50	50	35	15	50	31
15 HP	62	62	42	20	62	39

TOTAL INPUT CURRENT FOR TWO FAN MOTORS WILL EXCEED  
DOUBLE THE READING FOR ONE MOTOR ON A DUAL FAN  
DRYER AS THE STATIC PRESSURE CAUSES THE CURRENT  
DRAW TO INCREASE.

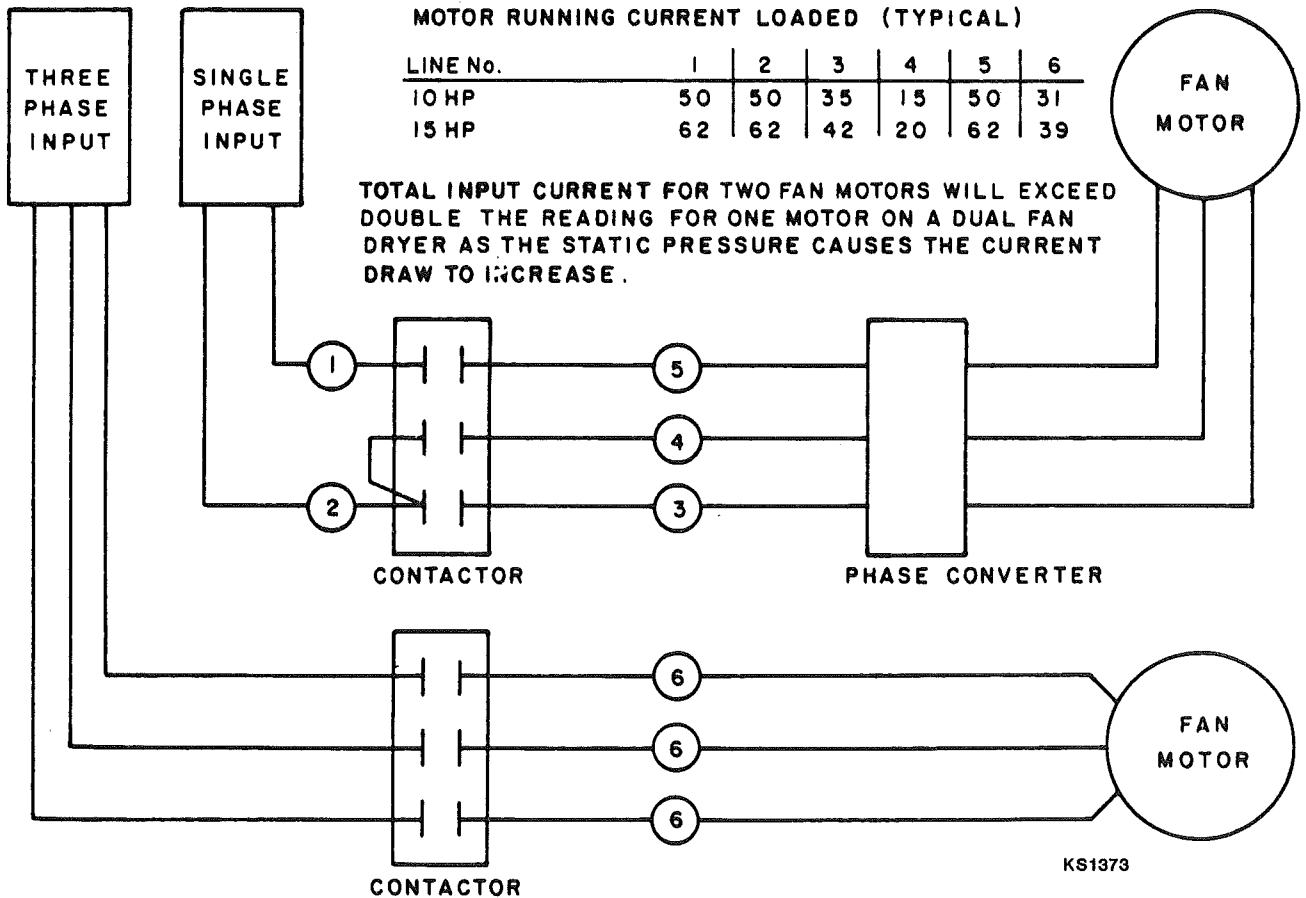



## FILLING EQUIPMENT (Customer Supplied)

1. Be sure that the system used has the grain moving capacity to fill the dryer faster than the grain shrinks and dries. If it does not, the Low Grain Timer will time out and shut down the dryer when the FILL switch is in the AUTOMATIC position and the grain level in the dryer

is low, lighting the LOW GRAIN and LOW BIN lamps.

2. Fill equipment must be controlled by the dryer.
3. Take away equipment can be controlled by the dryer.

## CONTROL PANEL LIGHTS, SWITCHES AND METERS

### CONTROL PANEL LIGHTS

The control panel (See Figure 5, page 13) lights are designed to assist the operator in following normal operating procedures.

### MALFUNCTION LIGHTS

The three top lights indicate a malfunction when ON. The COVER OPEN lamp, indicates the rear discharge door is open when ON, and will shut the dryer down.

The LOW GRAIN lamp indicates that the Low Grain Timer has timed out due to low grain in the dryer and shuts the dryer down.

The LOW TEMP lamp indicates the plenum has not reached a preset temperature when lit. The dryer can be run but cannot be switched from the START-UP to the RUN position until the set point has been reached. The low temperature thermostat, located in the control box upper right hand corner, should be set 20° to 30° below operating temperature.

### STATUS LIGHTS

The remaining vertically aligned lights show the status of their related components. By comparing the lights that are ON to the wiring schematic, it is possible to determine the status of the indicated components. If the component lamp is ON, that component is functioning as expected.

### START UP-RUN SWITCH

The START UP-RUN switch is located near the top of the control panel. When the switch is in the START UP position, the dryer fans, burners, and discharge motor can be operated independently of each other. This switch must be in the START UP position to start

the dryer. After the fans, burners, and discharge system are operating and the plenum temperature has exceeded the low temperature set point, the START UP-RUN switch should be switched to the RUN position. In this mode the dryer will shut down if there is a malfunction of the fans, burners, discharge system, grain take-away equipment or the dryer runs out of grain (the low grain timer times out shutting down the dryer). The dryer should never be left unattended unless the START UP-RUN switch is in the RUN position.

The FANS switch is located in the center about one-third of the way down from the panel top. The FANS switch is set to the START position and released, it then moves to the RUN position, the first fan starts, then after a 6 second delay, the second fan starts.

The BURNER switch in the ON position provides spark for burner ignition. In the OFF position it shuts down the burners.

The FILL switch is a 3 position switch. In the MANUAL and in the AUTOMATIC position it starts and stops the auxiliary grain fill equipment to keep the dryer full of grain while the dryer is running. In the OFF position it shuts down the auxiliary grain fill equipment.

The MANUAL SPEED CONTROL potentiometer is used to set the grain discharge rate in the manual mode.

The LOW BIN lamp lights when calling for grain. After a .1 to 8 minute delay timer times out, the fill equipment starts as does the low grain timer. If the low grain timer times out, the dryer shuts down.

# CONTROL PANEL

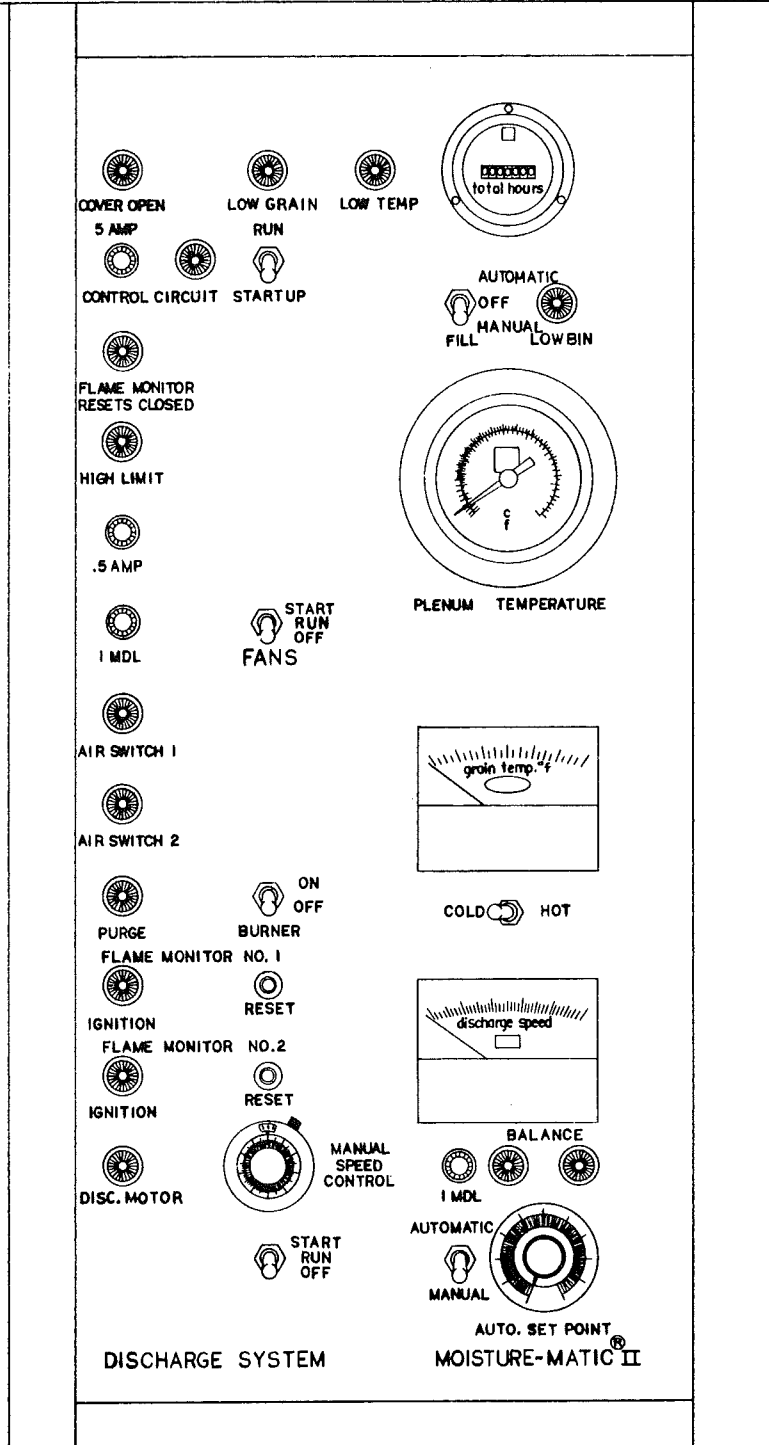

KS1363

Figure 5 - Control Panel

The discharge system START-RUN-OFF switch controls the discharge auger and auxiliary take-away equipment if connected.

The Moisture-Matic®II AUTOMATIC/MANUAL switch is used to set the moisture control for manual or automatic operation. When it is in MANUAL, the MANUAL SPEED CONTROL potentiometer controls the grain discharge speed. When it is in AUTOMATIC the Moisture-Matic®II controls the grain discharge speed.

The AUTO SET POINT potentiometer is used when the Moisture-Matic®II is in the MANUAL position to balance the system. When the Moisture-Matic®II is in the AUTOMATIC position the AUTO SET POINT potentiometer can be used to increase or decrease the desired moisture content of discharge grain. To increase the moisture content of discharge grain the AUTO SET POINT potentiometer must be turned counterclockwise. To decrease the moisture content of discharge grain the AUTO SET POINT potentiometer must be turned clockwise.

The TOTAL HOURS meter records the number of hours of dryer operation.

The PLENUM TEMPERATURE meter indicates the temperature inside the plenum.

The GRAIN TEMPERATURE meter indicates the grain temperature in the dryer in the heat (HOT) or cool (COLD) chambers. It has no effect on operation.

The DISCHARGE SPEED meter indicates the speed of the discharge system.

The FLAME MONITOR NO. 1 provides a source of high voltage for ignition, a power circuit for FLAME MONITOR NO. 2 and a flame sensing circuit. The trial period for flame is 10 seconds and if no flame is sensed the monitor will shut off ignition to the burner and trip FLAME MONITOR.

The FLAME MONITOR NO. 2 provides a source of high voltage for ignition, a relay circuit for gas solenoid power and a flame sensing circuit. The trial period for flame is 10 seconds and if no flame is sensed the monitor will shut off ignition and solenoid power closing off gas to the burner and tripping FLAME MONITOR.

The FLAME MONITOR RESETS CLOSED lamp goes OFF if one of the flame monitor reset buttons comes out and shuts down the dryer. The only lamp ON is the CONTROL CIRCUIT.

The CONTROL CIRCUIT lamp is normally ON and when it goes OFF, it indicates that the 2 amp fuse has opened or that AC power to the control has failed, shutting down the dryer.

THE HOT-COLD switch is used to read grain temperature from two thermistors. One thermistor is located in the heat section (HOT) and one thermistor is located in the cool section (COLD). This switch does not effect operation in any way.

BALANCE lamps may be on when in the MANUAL model of operation.

When in the AUTOMATIC mode and incoming grain moisture content is constant the BALANCE lamps are normally OFF. BALANCE lamps ON indicate a change in the moisture content of incoming grain has taken place and that the Moisture-Matic®II system is adjusting the discharge speed to maintain the pre-set moisture content of discharged grain.

## DRYING INFORMATION

### MOISTURE-MATIC® II

The Moisture-Matic System regulates the discharge rate of grain to maintain moisture at a pre-set level. It senses grain temperature.

### DRYING RATE

Drying rate is largely affected by physical characteristics of the grain. Variety, fertilization program, rainfall, sunlight (degree days), planting date and hail and storm damage all affect drying rate. Dryer capacity changes of up to 30% have been observed simply by changing from one field of corn to another of equal moisture content.

Capacity stated by industry standards is for 10 point moisture removal based on 25% dried to 15% moisture content. Five point is from 20% to 15%. Drying below 15% is slower and drying to 13% will reduce capacity as much as 30%.

Trash in grain reduces the drying rate and may cause uneven drying and flow patterns.

## DRYING TEMPERATURE LIMITS

Commonly dried grains have various maximum allowable drying temperatures depending upon anticipated storage, handling, and end usage.

Excessive temperatures affect palatability to livestock, milling, germination and cracking. Commonly accepted temperature limits are shown in the chart on this page.

## COOLING

Cooling is controlled by the cooling chamber doors. Maximum cooling occurs with the doors closed and minimum cooling with them open. Less cooling allows faster drying. To achieve a maximum drying rate, use an aeration bin to cool the grain with a minimum airflow of 1/2 CFM per bushel and leave the cooling doors open. If the cooling doors are abruptly closed, the plenum temperature will rise so rapidly (faster than the modulating valve can operate) it will trip the high limit switch.

## DRYING IN GENERAL

### CORN

Corn is the most commonly dried grain, thus general drying instructions apply to it.

Clean grain dries faster, more cheaply and more uniformly. All possible trash should be removed in harvesting.

**IMPORTANT:** Drying equipment should be serviced at least daily. Heating and cooling chambers should be inspected and all foreign material removed. Perforated walls may need cleaning to remove foreign material. Drying temperature, flow rate, and moisture content are established as shown in the operation section.

### SOYBEANS

Soybeans are not dried as a common practice; however, they are dried successfully by operating at a lower temperature with added inspection for cracks and special handling care.

## WHEAT

Wheat kernels are smaller than corn and pack more densely causing higher resistance to air flow. The increased resistance results in drying capacity somewhat below that of corn.

Fill dryer with fan off.



**WARNING:** Check and clean the inside of the dryer heating and cooling chambers daily or more often if needed. Most dryer fires are caused by poor house-keeping.

---

### RECOMMENDED DRYING TEMPERATURE °F\*

---

Grain	
Corn	220°
Soybeans	130°
Wheat	170°

---

**NOTE:** When drying seed or food grade lower temperatures must be used and capacity will be reduced.

\*Standard modulating valves supplied with Kan-Sun Dryers have a minimum control range of 140° F. Drying below this temperature requires manual regulation or substitution of a low temperature modulating valve.

# INITIAL START-UP INSTRUCTIONS

## GENERAL

**IMPORTANT:** Inspect for and remove any foreign material (nuts, bolts, tools, parts, etc.) from the grain columns, discharge auger and heat chambers before filling the dryer with grain.

1. Flip all the toggle switches on the control panel to the OFF position.
2. Liquid Propane (LP) Fuel
  - A. Turn the LP inlet hand valve (Figure 6 ) 90° to the piping to shut off the LP at the dryer.
  - B. Turn the main hand valve (Figure 6 ) 90° to the piping to shut off the gas to the burner.
  - C. Open the LP valve at the source.
3. Natural Gas (NG) Fuel
  - A. Turn the NG hand valve 90° to the piping to shut off the NG at the dryer.
  - B. Open the NG valve at the source.

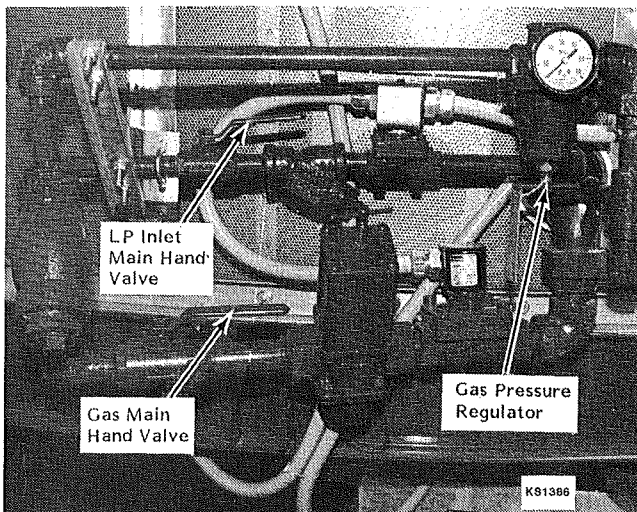

Figure 6 - LP Piping

4. Adjust the high limit thermostat (Figure 7 ) (located in the upper right corner of the control cabinet) 30-50° above the desired drying temperature or just enough to avoid nuisance shutdowns. (See Recommended Drying Temperatures, page 15.)
5. Adjust the low temperature thermostat (Figure 7) (located in the upper right corner of the control cabinet) 20° to 30° below dryer operating temperature to

avoid nuisance shutdowns. (See Recommended Drying Temperatures on page 15.)

6. A. Turn the LP inlet hand valve parallel to the piping.
- B. Set the LP gas pressure at 10 PSI as indicated by the gas pressure meter on the pressure regulator using the "T" handle but only while burner is on.



**CAUTION:** Check the modulating valve in gas manifold to be sure the "T" handle has **NOT** been turned all the way in to the wide open position. The "T" handle should be halfway between the closed and fully open position.

7. Set the .1 to 8 minute adjustable delay timer to start the auxiliary fill equipment to ensure that the grain level in the dryer does not expose the perforations on the peak panels. This delay prevents nuisance starting and stopping of the fill equipment.
8. Turn on the main electric power supply to the dryer. The CONTROL CIRCUIT, FLAME MONITOR RESETS CLOSED and HIGH LIMIT lights come ON.

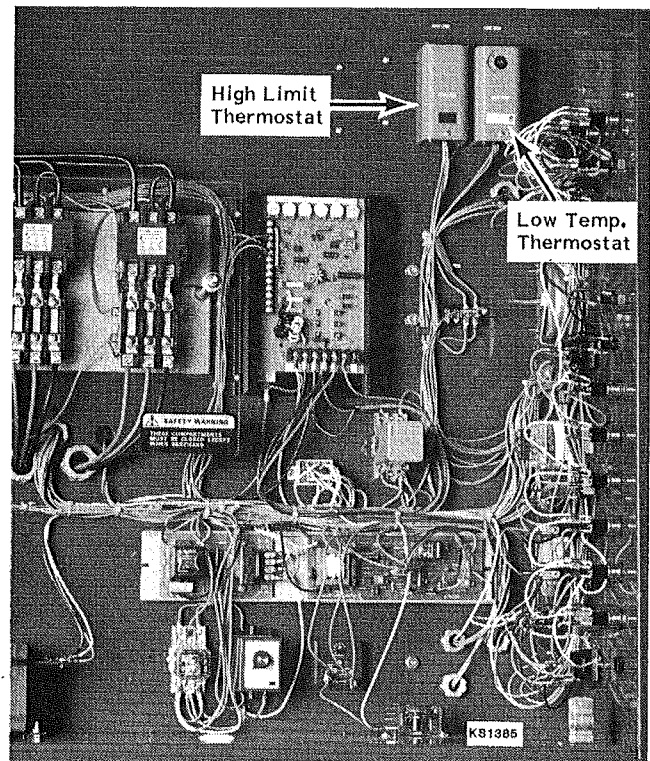

Figure 7 - High Limit and Low Temp. Thermostats

- Place the START-UP/RUN switch in the START-UP position.

### FILLING THE DRYER



**CAUTION:** Do not allow anyone to be in the dryer when filling it with grain. Always turn off and lock the electric power supply to the control cabinet before allowing anyone to work in the dryer.

- Flip the FILL switch (AUTOMATIC/OFF/MANUAL) to the MANUAL position (bypassing the 0-60 minute Low Grain Timer).
- The LOW BIN lamp lights.

**NOTE:** Either start with dry grain or be prepared to catch wet grain and recycle it until it starts to come out dry.

- After the adjustable .1 to 8 minute delay timer, the dryer fills with grain up to the rotary switch in the hopper stopping the auxiliary fill equipment.
- The LOW BIN lamp goes off.



**WARNING:** Check and clean the inside of the dryer heating and cooling chambers daily or more often if needed.

### SETTING THE LOW GRAIN TIMER

**IMPORTANT:** If the timer is set at 0, the dryer will shut down when the FILL toggle switch is flipped from MANUAL to AUTOMATIC.

- Set the adjustable grain fill delay (Figure 8) for the desired delay time (.1 to 8 minutes).
- Flip the FILL switch to the MANUAL position. Turn the timer control knob (Figure 8) to 20 minutes. The fill equipment **will start after** the adjustable .1 to 8 minute delay if the LOW BIN light is on calling for grain.
- Check the fill equipment refill time a few times. The LOW BIN light will come on when the Bin Switch in the hopper calls for grain and will go out when the hopper is full. The length of time that the LOW BIN light is on is the refill time (including the .1 to 8 minute delay).
- Average the refill time and reset the Low Grain Timer to run a little longer than actual. For example if it takes the fill equipment an average of 5 minutes

to refill the dryer (including the .1 to 8 minute delay), set the Low Grain Timer to run about 10 minutes.

**NOTE:** The Low Grain Timer does not operate when the FILL toggle switch is in the OFF position.

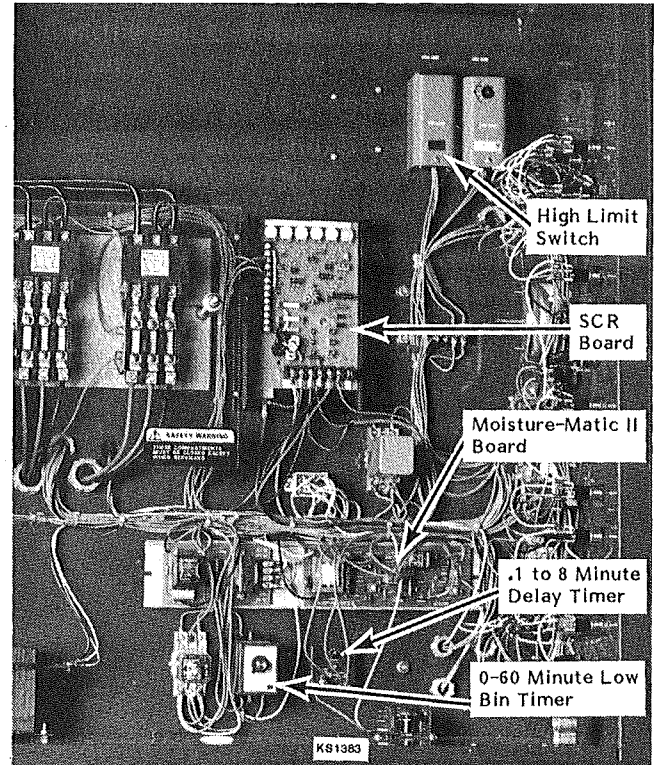

Figure 8 - Control Cabinet (Inside)

### STARTING THE BURNERS

- Start the fans by setting the FANS toggle switch to the START position. There is a 6 second delay between fan No. 1 starting and fan No. 2 starting. Check that AIR SWITCH 1 and AIR SWITCH 2 lamps come on.
- Open the gas main hand valve (Figure 9) half way.
- After a 15 second delay the PURGE lamp comes on. Flip the BURNER SWITCH to the ON position. Then the IGNITION lamps come on and the burners light.

**NOTE:** The purge is a safety feature that allows the fans to purge the heat chamber of any unburned gases that may remain after a burner has been shut down for any reason.

- After the flame is established, **slowly** open the gas main hand valve all the way (handle parallel to the piping).

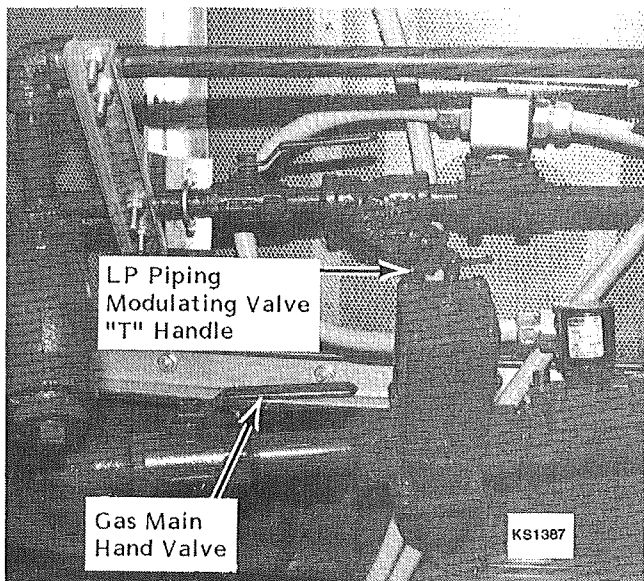

**Figure 9 - LP Piping (Gas Main Hand Valve)  
(Modulating Valve "T" Handle)**

**NOTE:** Opening the gas main hand valve slowly will prevent possible freezing of the LP gas line and also prevent the temperature from rising too fast. If the temperature rises too fast, the high limit switch will trip out and the dryer will shut down.

5. If the LP gas line freezes, close the gas main hand valve and flip the BURNER switch OFF. After the gas line thaws out repeat steps 3 and 4 but open the gas main hand valve **slower**.

**NOTE:** The Ignition Board is electronically timed so that the ignition system will spark and hold the solenoid gas valves open for a "trial ignition" period (10 seconds). If the burner does not light, the system will "lock out" (after the 10 second trial period) closing the gas solenoid valves and the ignition resets will trip, shutting down the complete dryer.

6. Push the ignition reset button and then restart the dryer, flip the BURNER switch OFF then ON again, a new trial for ignition will take place.

**NOTE:** If the burners fail to light, check that the status lamps through purge are ON, check LP or NG pressure, check that spark is present at the electrode, and check the ignition board as explained in the maintenance section.

7. If the High Limit Switch trips out, close the gas main hand valve and flip the

BURNER switch OFF. Push the reset button on the High Limit Switch (located in the upper right corner of the control cabinet) to reset it.

**NOTE:** When the High Limit Switch trips out the dryer will shut down. The fans and burners will have to be restarted.

8. Start the fans by setting the FANS toggle switch to the START position. There is a 6 second delay between Fan No. 1 and Fan No. 2 starting. Check that AIR SWITCH 1 and AIR SWITCH 2 lamps come on.
9. Open the gas main hand valve half way.
10. Flip the BURNER switch to the ON position, the IGNITION lamps come on and the burners light.
11. Gas Pressure - gas pressure should read 2-3 pounds above what is required to maintain operating temperature to allow for temperature variations from day to night operation.

#### **SETTING BURNER OPERATING TEMPERATURE**

**NOTE:** Refer to the Recommended Drying Temperatures on page 15. Temperatures shown are initial settings and may have to be adjusted for local crop and weather conditions.

1. With the burners operating, set the operating temperature by adjusting the modulating valve "T" handle.
2. Turn the "T" handle on the modulating valve IN to increase temperature and OUT to decrease temperature (see Figure 9). There is a temperature gauge mounted on the control panel.

**NOTE:** After the dryer has been operating for couple of hours the modulating valve will be functioning properly. It will not be necessary to adjust them for future start-ups unless the burner operating temperature is to be changed.

#### **OPERATION OF THE DISCHARGE SYSTEM WITH MOISTURE-MATIC® II**

1. The grain discharge auger and sweep is driven by a 3HP (DC) motor.
2. The discharge system is started by setting the DISC.MOTOR START/RUN/OFF switch to the START position.

3. The discharge system will operate as follows when the Moisture-Matic®II's switch is in the MANUAL position. The Moisture-Matic®II is bypassed and power flows directly to the discharge motor. When the Moisture-Matic®II is in the MANUAL position the discharge meter will run at the speed set by the MANUAL SPEED CONTROL dial.
4. The discharge system will operate as follows when the Moisture-Matic®II's switch is in the AUTOMATIC position.
  - A. The discharge motor will run at the speed established by the MANUAL SPEED CONTROL until there is a change in the moisture content of the incoming grain. The Moisture-Matic senses the change and adjusts the discharge speed up or down.
  - B. When the moisture content of the incoming grain increases, the Moisture-Matic®II's system senses this and adjusts the speed of the discharge motor to slow down or stop to prevent the discharge of wet grain from the dryer.
  - C. When the moisture content of the incoming grain decreases, the Moisture-Matic®II's system senses this and increases the speed of the discharge motor to prevent the dryer from discharging overdry grain.

#### REAR DISCHARGE OVERLOAD DOOR

1. If the take-away system fails, the dryer will discharge grain until the rear discharge overload door (Figure 10) is raised by the grain.
2. When the overload door raises, the dryer will shut down and the COVER OPEN light will be ON.
3. When the problem has been corrected and the rear discharge overload door closes, the COVER OPEN light will be off.

4. If the FILL-AUTOMATIC/OFF/MANUAL switch is in the AUTOMATIC position and the .1 to 8 minute delay timer times out, the fill equipment will start to fill the dryer.

**NOTE:** If the Low Grain Timer times out due to lack of grain, the dryer will shut down.

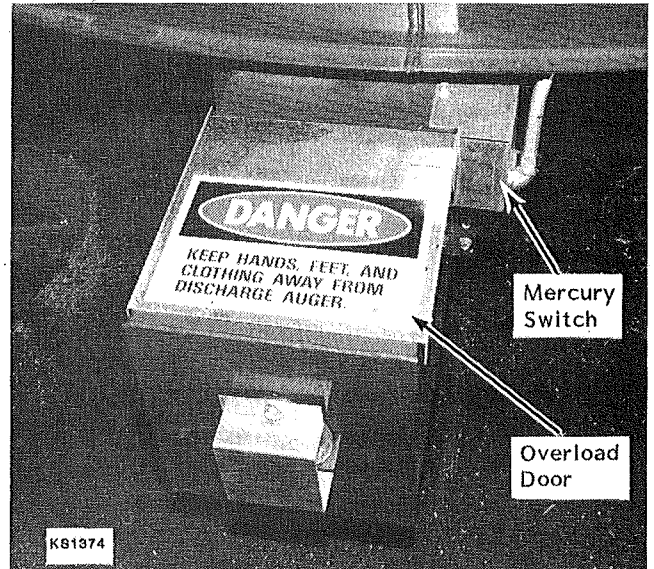

**Figure 10 - Rear Discharge Overload Door**

#### MANUAL CONTROL OF MOISTURE CONTENT

Manual control of a dryer is recommended for start-up. Moisture-Matic®II set to MANUAL.

1. Check and record grain moisture content every hour. Obtain a representative grain sample by collecting five 1-cup samples at 10 second intervals. Mix the samples thoroughly before testing.
  - A. If the moisture content of the dried grain is lower than desired, increase the discharge speed with the MANUAL SPEED CONTROL potentiometer.
  - B. If the moisture content of the dried grain is higher than desired, decrease the discharge speed with the MANUAL SPEED CONTROL potentiometer.
2. After any adjustment of the discharge speed, wait 1½ to 2 hours to make further speed adjustments since it takes that long for grain to pass through the dryer and for the full effect of the speed adjustment to be made on the moisture content.



## MOISTURE-MATIC®II AUTOMATIC MOISTURE CONTROL

1. When the dryer has discharged grain at the desired moisture content for 2 to 4 hours adjust the AUTO SET POINT potentiometer until the BALANCE lights above the dial go OFF.
2. Place the Moisture-Matic®II AUTOMATIC/MANUAL switch to the AUTOMATIC position. The discharge speed is now under control of the Moisture-Matic®II.
3. The Moisture-Matic®II system aids in controlling the discharge moisture content by varying the discharge speed.
4. Continue checking discharge grain moisture content every 60 minutes. Should the moisture content be consistently too wet or too dry, adjust the AUTO SET POINT dial clockwise (drier) or counter clockwise (wetter) respectively.
5. After any adjustment of the AUTO SET POINT dial wait 1½ to 2 hours before making further adjustments because of the lag in response due to the time it takes grain to pass through the dryer. A major cause of inconsistent discharge moisture content is too frequent adjustment of the AUTO SET POINT dial.

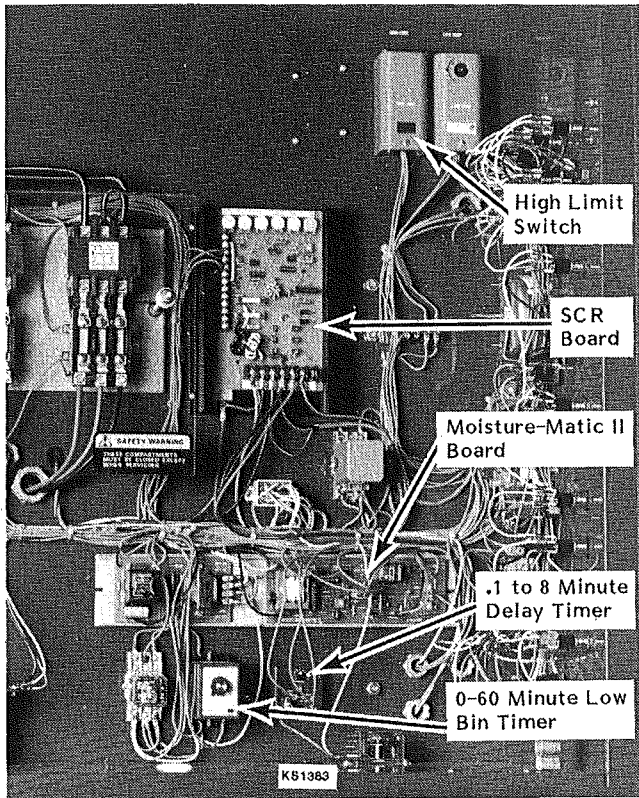

Figure 11 - Control Cabinet (Inside)

## FILL SYSTEM

1. There is an adjustable .1 to 8 minute delay in the grain fill circuit. It is activated when the FILL switch is ON and LOW BIN light is on calling for grain.
2. This delay prevents nuisance starting and stopping of the fill equipment. If the FILL switch is flipped to OFF and back to the AUTOMATIC position, the delay will recycle.
3. The Low Grain Timer (Figure 11) will shut the dryer down if there is an insufficient grain supply to fill the hopper. When the fill equipment starts, the Low Grain Timer will be activated. When the timer counts down to zero, the dryer will shut down.

## LOW GRAIN TIMER OPERATION

With the Low Grain Timer set to run 5 minutes longer than the grain refilling time, the timer will work as follows:

1. The timer will start when the fill equipment starts. The red light on the face of the timer will be on and the red needle on the timer dial will start to move to zero.
2. After the dryer refills, the LOW BIN light will go out and the timer red needle will automatically reset. The red light on the face of the timer will be out.
3. If there is insufficient grain to fill the dryer, the Low Grain Timer will time out and shut down the dryer. The low grain light will be on.
4. When the problem has been corrected, flip the FILL switch OFF then to the MANUAL position. Restart the fans, burners and discharge system. Flip the FILL switch to the AUTOMATIC position.



**CAUTION:** Turn off and lock the electric power to the dryer before any service work is performed.



**CAUTION:** Do not allow anyone to be in the dryer as the fill equipment will start automatically.

## DRYER SHUTDOWN FOR THE DAY

When dryer is full of grain:

1. Place the START-UP/RUN switch in the START-UP position.
2. Shut off the fuel valve at the fuel source and let the fuel burn out and dryer cool.
3. Place the BURNER switch in the OFF position.
4. Shut off the fuel valve at the dryer.
5. Stop the discharge motor by moving the START/RUN/OFF switch to the OFF position.
6. Continue to operate the fans for about 15 minutes to cool the grain. After cooling, stop the fans by placing the FANS switch to the OFF position.

## SECOND OR SUBSEQUENT DAY START-UP



**WARNING:** Check and clean the inside of the dryer heating and cooling chambers daily or more often if needed. Most dryer fires are caused by poor house-keeping.

**NOTE:** Open the fuel at the source before starting the dryer.

1. Place the START-UP/RUN switch in the START-UP position.
2. Start the fans by setting the FANS toggle switch to the START position.
3. Set the BURNER switch to the ON position.
4. LP Fuel - Open the dryer valve half way until the dryer warms up.  
NG Fuel - Open the dryer valve until sufficient flow is obtained for ignition.
5. Start the DISCHARGE SYSTEM and set the Moisture-Matic AUTOMATIC/MANUAL switch in the AUTOMATIC position.
6. Slowly set the START-UP/RUN switch to the RUN position.

## EMPTYING THE DRYER

When the last grain to be dried has been put into the dryer, stop the discharge motor before the grain has dropped below the perforated area in the grain receiving assembly. Dry this remaining grain for approximately 6 minutes per point. Then shut off the fuel valve at the source. Let the burners burn the gas until out. Then shut off the burners and cool this remaining grain approximately 20 minutes. After cooling, shut off the fans and empty the dryer by starting the discharge

motor and waiting until the last of the grain has been removed by the take-away equipment. Then shut off the discharge motor.

## OFF SEASON STORAGE



**WARNING:** Disconnect and lock out the Main Power Supply anytime work is performed inside the dryer.

1. Cover burner shields with plastic.
2. Remove cooling floor sections and remove grain from the bottom of the dryer.
3. Brush (non-metallic), blow or wash all dirt and residue from the dryer walls and floors. Use a power washer on the outer screens if dirt has filled the perforations.
4. With no one in the dryer, reconnect power to the dryer and start the discharge motor. Auger any trash out of the discharge auger. Hose off the floor, sump and U-trough.
5. Disconnect the power to the dryer and replace the cooling floor sections.
6. Grease the fan motors with Chevron SRI-2 or equivalent.
7. Use compressed air to blow any dirt from the control box.
8. Release spring tension on the regulator and modulating valves.
9. Disconnect the power and lock the control box doors.

## SEASONAL MAINTENANCE

### MAINTENANCE INSIDE MACHINE FOR START-UP

1. Turn power off at main distribution panel.
2. Clean out heating and cooling chamber.
3. Remove cover from burner.
4. Grease fan motor at top and bottom bearing.
  - A. Apply grease until it comes out relief port opening. Use Chevron SRI-2 or other approved lubricant.
5. Check oil in 50:1 gear box and grease.
  - A. Oil must be at least  $\frac{1}{4}$ " over gear.
  - B. Grease top bearing with gun grease.
6. Grease U-joint on 50:1 drive shaft.

### MAINTENANCE OUTSIDE MACHINE

7. Grease belt tightener pivot.

## LUBRICATION

Lubrication is applied to all required areas before leaving the factory; however, a lubrication schedule should be maintained as described below.

ITEM	LUBRICATION REQUIRED	INTERVAL
50:1 Gearbox Oil Level	Fill $\frac{1}{4}$ " over gear with SAE 90 gear lubricant.	Maintain proper level. Check every 100 hours.
50:1 Gearbox Grease Fitting	Use five (5) strokes of gun grease.	And at beginning and end of season.
U-Joints	Use one (1) stroke of gun grease.	Every 50 hours of operation.
Fan Motor(s) & Metering Motor	Lubricate with SRI-2 (Chevron) grease or equivalent. (Equivalents below)	Prior to operation and end season

### FAN AND METERING MOTOR GREASES

Chevron SRI-2 Standard Oil of California  
 Aeroshell #16 Shell Oil Company  
 Hi Temp Texaco, Inc.  
 Andok 260 Humble Oil  
 Rykon #2 American Oil

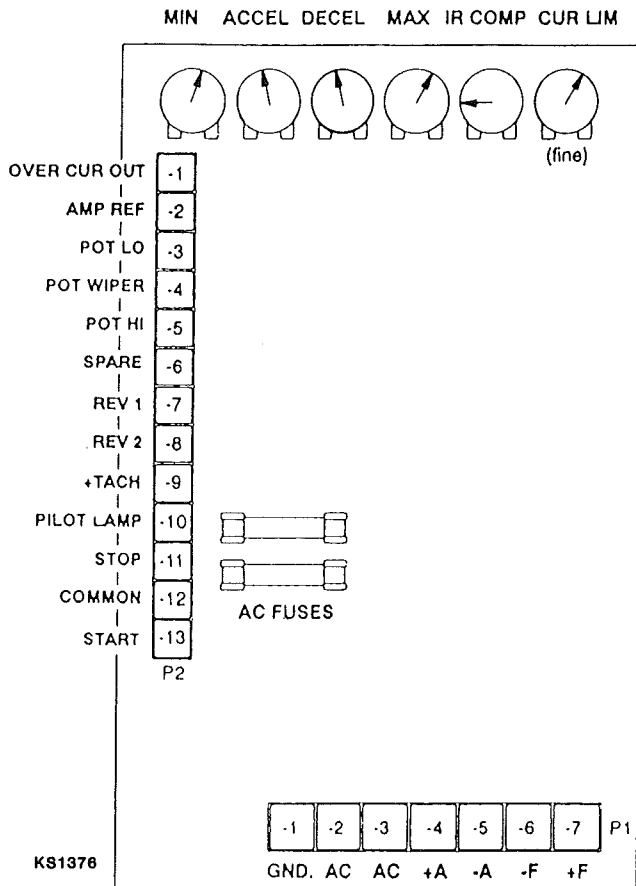

FIGURE 12 – 500 SERIES SCR BOARD

## SCR BOARD TRIM POT ADJUSTMENT PROCEDURE

**NOTE:** Figure 12 shows approximate trim pot settings. Follow adjustment procedure below for final calibration.

Trim Pot	Function	Adjustment
<b>MIN.</b>	Sets Minimum Motor Speed when Speed Control is set at zero. CW rotation will increase minimum motor speed.	<ol style="list-style-type: none"> <li>1. TURN DRIVE POWER OFF!.</li> <li>2. Connect DC Voltmeter: + to + Arm, - to - Arm.</li> <li>3. Turn Drive Power ON. Set SPEED control to zero. (Fully CCW)</li> <li>4. Rotate Min pot CW until desired Min speed is reached (18 volts on DC meter connected between Arm (+) and Arm (-) or .14 reading on discharge meter or 200 RPM on DC motor output shaft.</li> </ol>
<b>MAX.</b>	Sets Maximum Motor Speed when Speed Control is set at maximum (10) 100% rotation CW. CW rotation of MAX trim pot increases maximum motor speed.	<ol style="list-style-type: none"> <li>1. TURN DRIVE POWER OFF!</li> <li>2. Connect DC Voltmeter: + to +Arm, - to -Arm.</li> <li>3. Turn power on. Set SPEED control at 100% (10).</li> <li>4. Adjust MAX pot for 170 volts on DC meter connected between Arm (-) and Arm (+), or 1.0 reading on discharge meter or 1750 RPM on DC motor output shaft.</li> </ol>
<b>ACCEL</b>	Allows adjustment of Acceleration.	<ol style="list-style-type: none"> <li>1. CW rotation increases time of acceleration.</li> </ol>
<b>DECEL</b>	Allows adjustment of Deceleration.	<ol style="list-style-type: none"> <li>1. CW trim pot rotation increases deceleration time.</li> </ol>
<b>I.R. COMP.</b>	Provides a means of improving speed regulation in the armature feedback mode. If a change in motor speed during a load change is of no concern, rotate this trim pot fully CCW.	<ol style="list-style-type: none"> <li>1. Set Speed pot at 50%.</li> <li>2. Observe motor speed during a no load condition.</li> <li>3. Apply a full load to the motor.</li> <li>4. Adjust the I.R. COMP. trim pot CW (while the load is applied) until the no load motor speed is maintained.</li> </ol>
<b>CUR. LIM.</b>	Limits DC motor armature current (torque) to prevent damage to the motor or control. The current limit is set for 125% of the rated motor current. CW rotation of this trim pot increases the armature current (or torque produced).	<ol style="list-style-type: none"> <li>1. TURN DRIVE POWER OFF!</li> <li>2. Connect a DC ammeter in series with the + Arm line (between +A on motor and +Arm on the control). Preset the current limit trim pot CCW.</li> <li>3. Turn power on and set Speed pot to 50%.</li> <li>4. Increase the motor load until the motor stalls (zero RPM).</li> <li>5. Set CUR.LIM. trim pot to 125% of the rated motor armature current (see "TRIM POT CHART" on page 22).</li> </ol>

## TROUBLESHOOTING

The following table is provided as an aid to the Operator to determine the cause and corrective action required for problems occurring during dryer operation. If the corrective action recommended does not correct the problem, contact an authorized Kan-Sun Dryer Serviceman.

PROBLEM	POSSIBLE CAUSE(S)	CORRECTIVE ACTION
Control Circuit Light Off	Power disconnected. Transformer input fuse blown (2 amp slow-blow 460 volt). Control circuit fuse blown (5 amp).	Connect power. Replace fuse.  Replace fuse.
Flame Monitor Reset Light Off	Flame Monitor Reset(s) tripped.	Reset.
Motors fail to start (no power)	Start-Up/Run Switch in RUN. High Limit Switch tripped. Motor Overload tripped.	Switch to Start-Up. Reset. Reset.
Fan motor(s) hum, but fail to start, or turn slowly.	Defective bearings.	First shut off and lock out power supply. Check motor bearings (spin blade by hand).
Magnetic Starter(s) trip out repeatedly.		Call authorized serviceman.
Fan runs but Air Switch doesn't light.	Check 1 amp fuse. Check flap on air switch. Fan rotation.	Replace. Make sure it is free and not missing.
Machine runs through purge period, but fails to ignite or flame out occurs before temperature reaches drying temperature.	Low gas pressure.  Modulating valve improperly adjusted.  Improper electrode gap or cracks.	Set proper pressure with regulator. Readjust modulating valve.  Adjust or replace.
High Limit Thermostat kicks out repeatedly.	Check High Limit Thermostat setting.  Check for clogged heating chamber walls.  Check temperature gauge for accuracy.	Readjust as required.  Clean dryer chamber.  Replace gauge.
Machine stops when switched into the RUN circuit.	Check the circuit indicated by the status lights.	Repair indicated circuit.

## TROUBLESHOOTING

PROBLEM	POSSIBLE CAUSE(S)	CORRECTIVE ACTION
Machine will not achieve desired temperature or temperature is erratic.	<p>Check supply tank fill and pressure for LP units; supply pressure on NG units.</p> <p>Check regulator and modulating valve for proper adjustment.</p> <p>Check temperature gauge.</p> <p>Check excess flow valve at fuel supply for clicking noise or frost indicating blockage.</p> <p>Check for frost on supply line indicating blockage.</p> <p>Check for correct burner orifice.</p>	<p>Contact fuel supplier.</p> <p>Readjust as required.</p> <p>Replace gauge.</p> <p>Call LP Serviceman.</p> <p>Call LP Serviceman.</p> <p>Replace, adjust or drill out.</p>
Uneven moisture content of discharged grain.	<p>Check to see if machine is level.</p> <p>Sweep arms not level.</p>	<p>Level machine.</p> <p>Check that sweep arms are sweeping parallel to the lower edge of the inner perforated wall.</p>
Machine shuts down in RUN.	<p>Check for wet grain at Rotary Bin switch.</p> <p>Check gas pressure regulator and modulating valve setting.</p> <p>Improper high limit setting.</p> <p>Improper flame probe gap or cracks.</p> <p>Check secondary and high tension lines for cracks, nicks or looseness.</p>	<p>Increase low bin timer.</p> <p>Adjust as required.</p> <p>Reset.</p> <p>Readjust or replace.</p> <p>Replace or tighten.</p>
Status lights flicker, solenoids chatter, or unit shuts down repeatedly.	<p>Poor machine ground.</p> <p>Loose connections.</p>	<p>Tighten machine ground.</p> <p>Tighten as required.</p> <p>Contact authorized Kan-Sun Serviceman.</p>
Low dryer throughput.	<p>Grain overdried.</p> <p>More than 10 point moisture removed.</p> <p>Check moisture tester for accuracy.</p> <p>Improper drying temperature.</p> <p>Plugged perforated sheets.</p>	<p>Adjust SCR potentiometer.</p> <p>Allow more time.</p> <p>Replace if broken.</p> <p>Readjust temperature.</p> <p>Clean as required.</p>

## TROUBLESHOOTING

PROBLEM	POSSIBLE CAUSE(S)	CORRECTIVE ACTION
Plus (+) and minus (-) lights will not go off when calibrating Moisture-Matic®II control system.	Deadband potentiometer out of adjustment.	Adjust the deadband trim pot on Moisture-Matic®II board (R-7) until both lights stay off when turning moisture control dial two spaces on the scale.
Sweep and discharge auger DC motor will not run.	<p>Run - Start-Up switch not in Start-Up position.</p> <p>High limit light off. (High Limit control not reset.)</p> <p>Discharge motor relay coil burned out.</p> <p>SCR board fuse(s) blown.</p> <p>Moisture-Matic®II 1 amp fuse blown.</p> <p>Moisture-Matic®II board inoperative.</p> <p>SCR board inoperative.</p> <p>No power source</p> <p>Min pot on SCR board set too low.</p> <p>Worn or broken motor brushes.</p>	<p>Switch to Start-Up.</p> <p>Reset.</p> <p>Replace.</p> <p>Replace.</p> <p>Replace.</p> <p>Check output voltage between Arm (+) and Arm (-) which should be approximately 20 to 170 volts DC depending on the SCR speed control potentiometer setting. If no voltage, consult factory.</p> <p>Check output voltage between (+) and (-) terminals on Moisture-Matic®II board. Voltage should be approximately 3 to 10 volts DC depending on the SCR speed control potentiometer setting. If no voltage, consult factory.</p> <p>Repair power source.</p> <p>Adjust Min pot for 18 VDC between Arm (+) and Arm (-).</p> <p>Replace brushes.</p>
Sweep and discharge auger will not run.	<p>Belts loose.</p> <p>Belts broken.</p>	<p>Tighten belts.</p> <p>Replace belts.</p>

## TROUBLESHOOTING

PROBLEM	POSSIBLE CAUSE(S)	CORRECTIVE ACTION
Moisture-Matic®II does not control grain moisture.	Moisture-Matic®II MANUAL OFF-AUTO switch in MANUAL position. Bad thermistor. Check response with ohmmeter Reference thermistor chart, page 44. Bad Moisture-Matic®II board. Bad moisture control potentiometer. Check potentiometer with ohmmeter.	Switch to AUTOMATIC.  Replace if bad.  Replace. Replace.
Motor stalls or runs very slowly with speed control turned fully CW.	Low DC voltage.  Overload condition.  Worn motor brushes.	Should be above 108V. Max. speed set incorrectly. See "Adjustment Procedure" page 23. Reduce load or readjust Current Limit. Replace motor brushes.
Repeated fuse blowing.*	Low AC voltage. Overload condition. Worn motor brushes. Defective motor bearings. Failed electrical components.	Check AC supply voltage. Reduce load. Replace motor brushes. Replace motor bearings.  Return SCR board for repair.
Motor runs but will not stop.	Incorrect wiring.  Defective wiring. Failed component.	Check "Terminal Strip Wiring" sections. Check wiring. Return SCR board for repair.

\*Fuse Size: 20 Amp

Fuse Type: Bussman ABC-20 or Littlefuse 314020

**NOTE:** Both sides of VAC input to SCR board are fused.



**This page intentionally blank.**

# PARTS LIST

## AUGER - SWEEP

ITEM NO.	PART NO.	DESCRIPTION	QTY
1	475044	DISCHARGE SUMP BODY WELDMENT	1
2	475071	SUMP TROUGH	1
3	475053	SUMP TIE BOLTS	4
4	475040	AUGER WELDMENT, B"	1
5	439779	ATTACHMENT ANGLE	1
6	475048	DISCHARGE AUGER TUBE WELDMENT	1
7	475052	AUGER EXTENSION OVERLOAD DOOR	1
8	441966	SPRING (6" LONG)	1
9	444601	BELT TIGHTENER WELD'T	1
10	830017	DRIVE SHAFT	1
11	837742	SHEAVE 6.9" O.D.	2
12	475074	HUB 1 1/4" BORE WITH KEY	1
13	837739	HUB 1" BORE	1
14	833318	BELT IDLER	1
15	837356	DRIVE "V" BELT	1
16	475049	UNLOAD AUGER DISCHARGE	1
17	821372	BEARING 1" BORE WITH CASTING	1
18	820026	"U" JOINT	1
19	437752	GEAR BOX 50:1	1
20	834682	SWEEP ARM - SHORT	1
21	834683	SWEEP ARM - LONG	1
22	475170	MOUNTING CLIP LEVEL SWITCH	1
23	475171	UA BULB MOUNT	1

ITEM NO.	PART NO.	DESCRIPTION	QTY
24	475050	1 1/4" BEARING FLANGETTE	1
25	475051	1 1/4" BEARING W/LOCKING COLLAR	2
26	821633	SWEEP ARM HUB ASSEMBLY	1
27	821364	SWEEP ARM FINGER ASSEMBLY	1
28	446360	SWEEP FIN TAIL BRACKET	2
29	821649	SWEEP FIN	2
30	833278	SWEEP FIN FINGER	2
31	441965	SWEEP FIN FINGER - CLEANER - (TEFLON)	2
32	475069	AUGER STUB SHAFT GUARD	1
33	475073	AUGER STUB SHAFT	1
34	475072	AUGER DRIVE SHAFT	1
35	475147	MERCURY SWITCH	1
36	475172	MERCURY SWITCH COVER	1
37	475150	LEG EXTENSION WELDMENT	6
38	833607	1/4 x 7/8 WOODRUFF KEY	1
39	475246	1/4 x 1/4 x 1 1/2 KEY STOCK	3
40	475140	SHIM - 20GA (QUANTITY AS REQUIRED)	-
41	836424	"DANGER" DISCHARGE AUGER DECAL	1

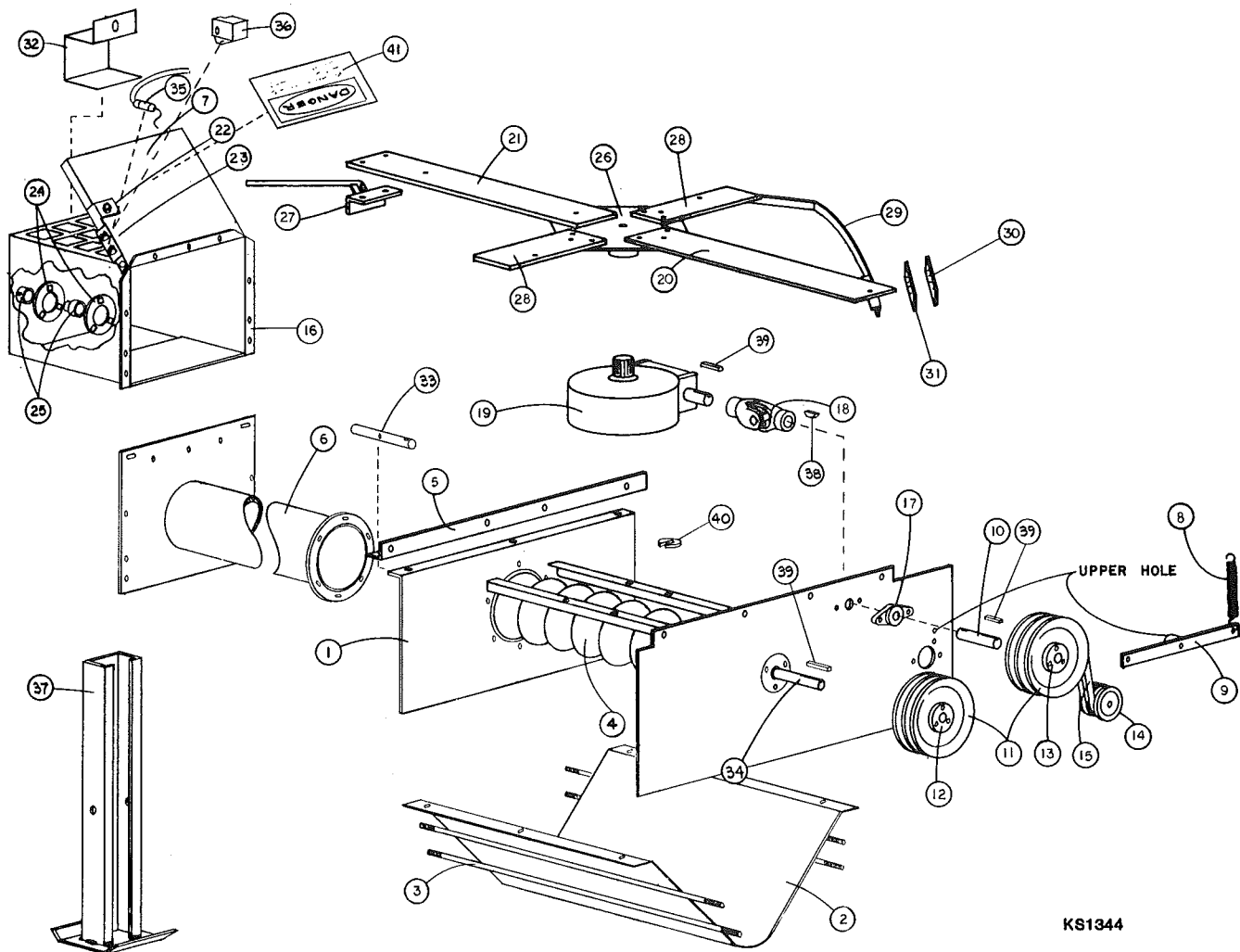

KS1344

# COOLING SECTION

ITEM NO.	PART NO.	DESCRIPTION	QTY 10'
1	475024	OUTER CONTROL BOX SHEET	1
2	834536	INNER CONTROL BOX SHEET	1
3	475023	OUTER DOOR SHEET	2
4	834534	INNER DOOR SHEET	2
5	475022	OUTER COOLING SHEET	1
6	475007	48" 10' INNER RAPE SHEET	1
7	438761	OUTSIDE CHANNEL RING	4
8	438760	INSIDE CHANNEL RING	6
9	438649	OUTER RING BOLTING TAB	4
10	833353	INNER RING BOLTING TAB	4
11	834589	PARTITION 4'	13
12	834600	PARTITION BOTTOM PVC	1
13	834599	PARTITION TOP PVC	1
14	834598	PARTITION BOTTOM DOOR	2
15	834597	PARTITION TOP DOOR	2
16	475011	DUMP GATE	16
17*	833194	STEP, COOLING CHAMBER	32
18	438912	ENTRANCE TUBE	2
19	438913	COLLAR	4
20	834718	BRACE ANGLE	13

\* ITEMS NOT SHOWN

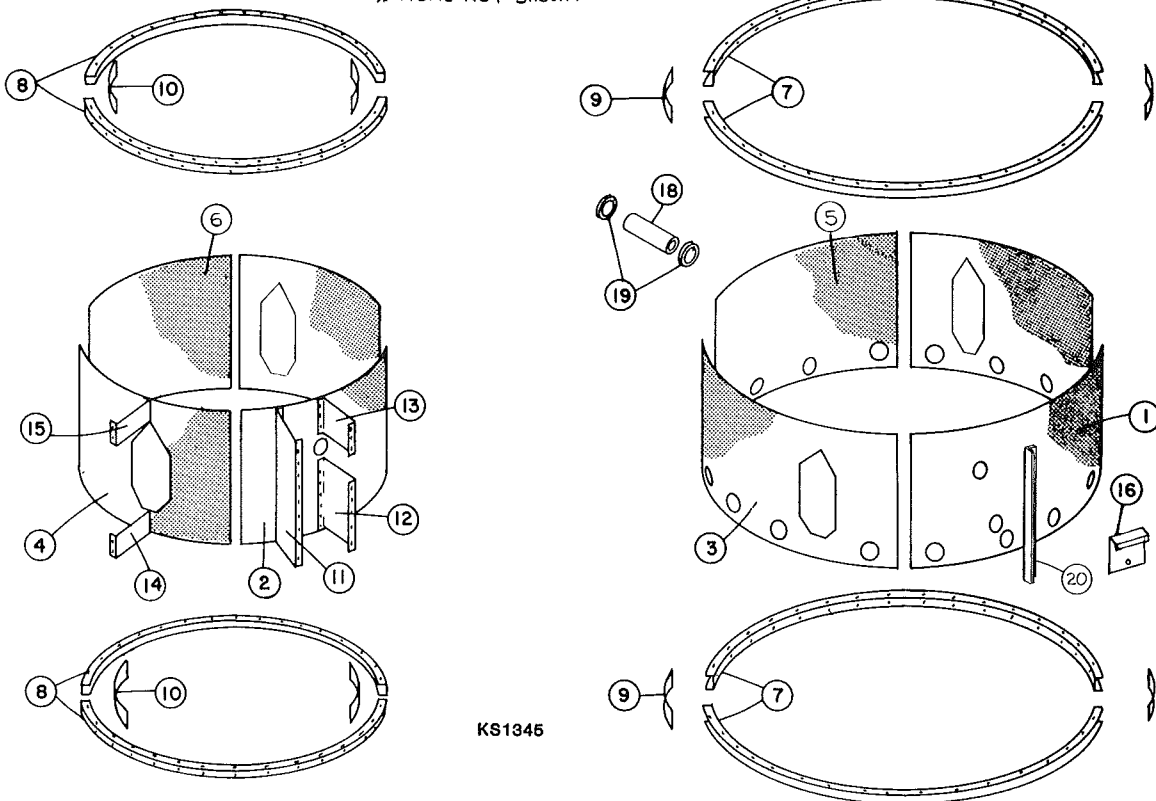

# HEAT SECTION

ITEM NO.	PART NO.	DESCRIPTION	QTY
			10'
1	834065	1/4" x 1/2" POP RIVET	288
2*	834133	1/4" x 3/16" POP RIVET	112
3	444762	OUTER 4' SHEET-10'	4
4*	095069	5/16"-18 x 3/4" TRUSS BOLT	100
5*	095316	5/16"-18 x 1/2" TRUSS BOLT	76
6	834531	INNER 4' SHEET-10'	4
7*	434632	5/16"-18 WHIZ HEX NUT	304
8	438761	OUTSIDE CHANNEL RING-10'	4
9	837524	5/16"-18 x 3/4" HWHCS	128
10	438760	INSIDE CHANNEL RING-10'	4
11	438649	OUTER RING BOLTING TAB	4
12	833353	INNER RING BOLTING TAB	4
13			
14	834589	PARTITION 4'	16
15	475104	CLEANOUT PLENUM STRIP LONG	2
16	475105	CLEANOUT PLENUM STRIP SHORT	2

\* ITEMS NOT SHOWN

REPLACEMENT POP RIVETS - 834065 - 1/4" DIA. x 1/2"  
 8' DIA. - 3' SECTION - 168 REQ'D  
 8' DIA. - 4' SECTION - 216 REQ'D  
 10' DIA. - 4' SECTION - 288 REQ'D

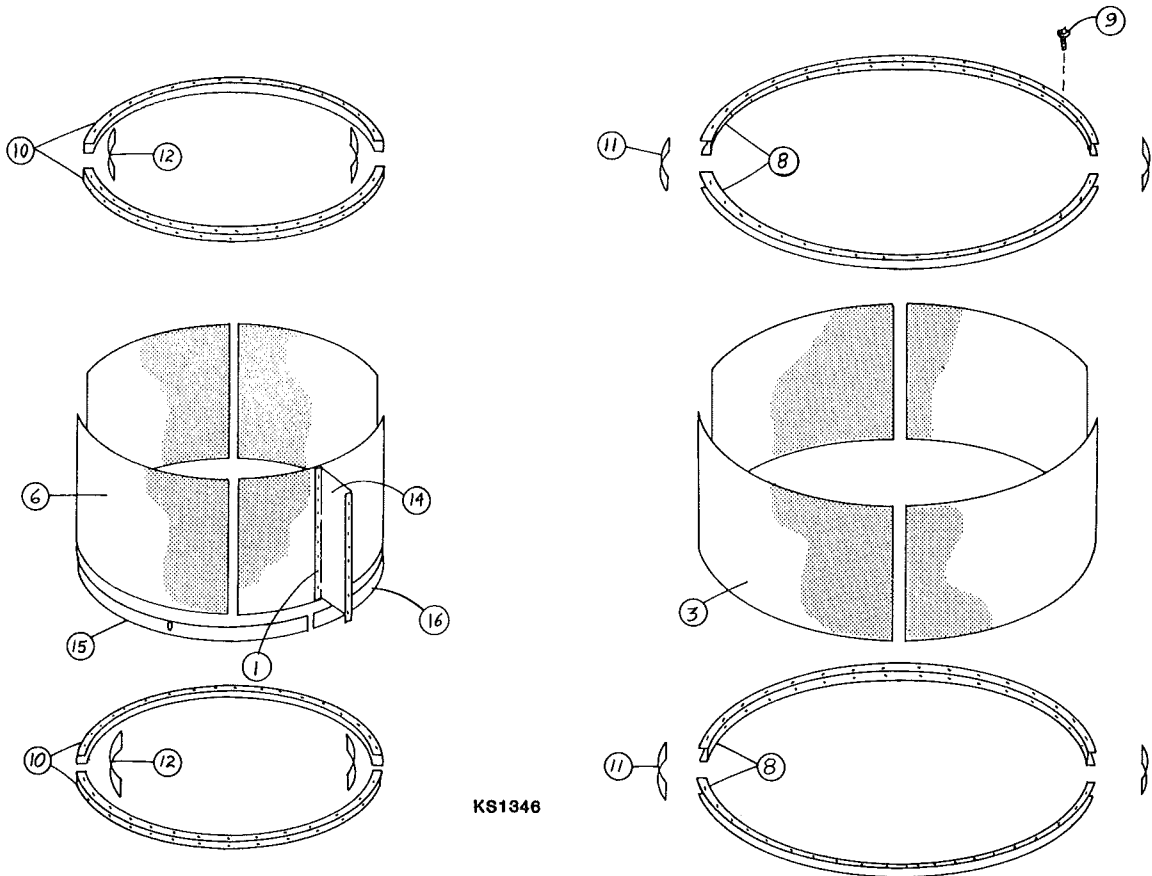

# CRAWL DOOR

ITEM NO.	PART NO.	DESCRIPTION	QTY.
1	830125	CRAWL DOOR COVER	1
2	830126	DOOR HANDLE	1
3	830127	DOOR CHAIN	1
4	440504	CRAWL DOOR FRAME	1
5	830114	CRAWL DOOR TOP	1
6	830115	CRAWL DOOR BOTTOM	1
7	830116	TOP FILLER ANGLE	1
8	830117	BOTTOM FILLER ANGLE	1
9	475210	"S" HOOK	1
10	836427	DECAL: "NOTICE-USE THIS DOOR" ETC.	1
11	836425	DECAL: "CAUTION-INSPECT INTERIOR" ETC.	1
12	837667	DECAL: "CAUTION-DO NOT ENTER" ETC.	1

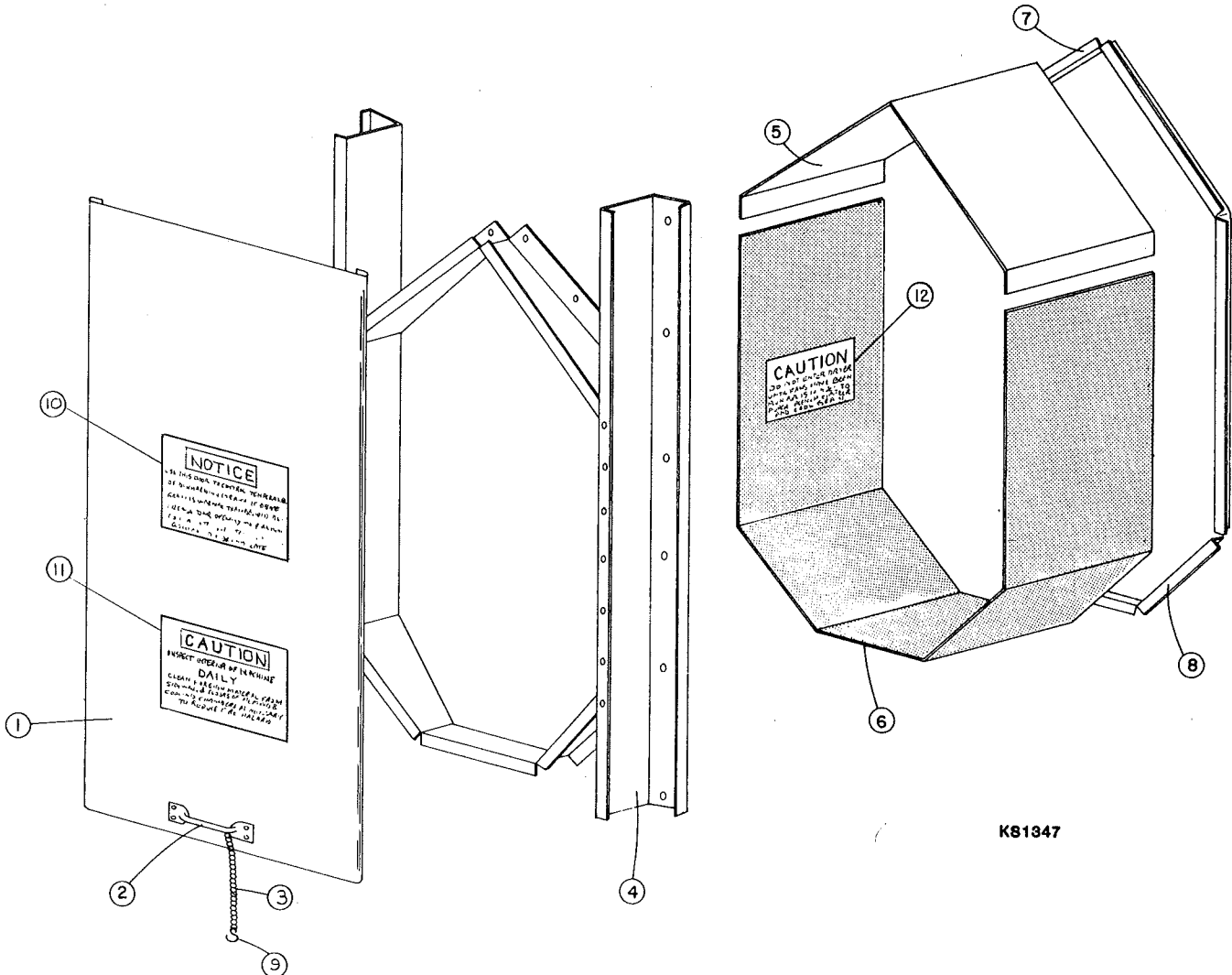

K81347

# 10' HEAT FLOOR

ITEM NO.	PART NO.	DESCRIPTION	QTY.
1	833372	PLENUM FLOOR END	2
2	475185	PLENUM FLOOR SIDE	1
3	475184	PLENUM FLOOR ENTRANCE	1
4	821305	PLENUM DOOR ASS'Y (INCLUDES HANDLE)	1
5	830126	DOOR HANDLE	1
6	475057	RIGHT HAND SUPPORT GUSSET	2
7	475056	LEFT HAND SUPPORT GUSSET	2
8	821659	PLENUM SUPPORT WELDMENT	2
9	833727	BURNER SHROUD SUPPORT	1
10	833221	FLOOR PLATE	2
11	475169	PIPE BUSHING MOUNT WELDMENT	1

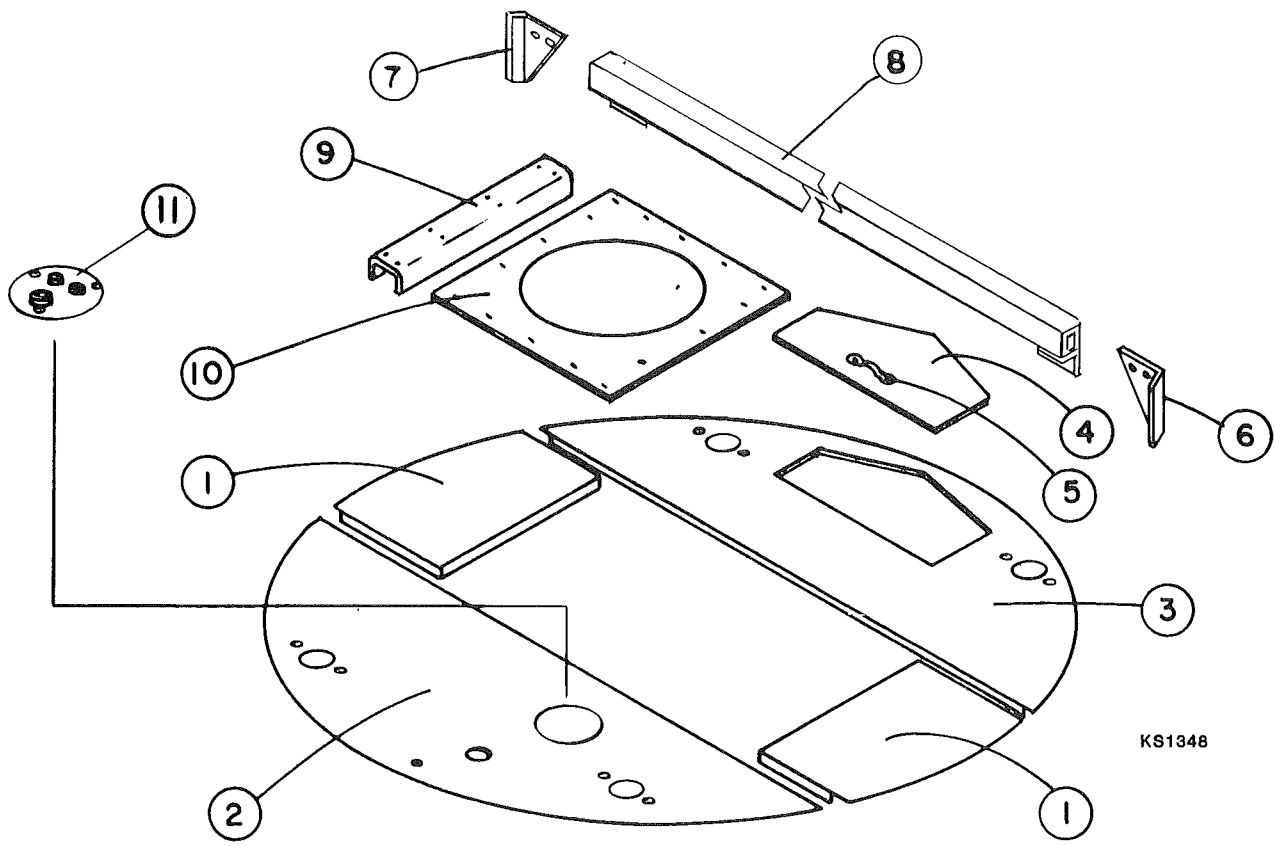

KS1348

# COOLING FLOOR

ITEM NO.	PART NO.	DESCRIPTION	QTY
1	475183	FLOOR SIDE PLATE	2
2	833356	FLOOR END PLATE	2
3	475108	CLEANOUT PIPE GASKET	4
4	475109	CLEANOUT FLOOR SEAL	4
5	833165	FLOOR HOPPER COVER	1
6	438712	LATCH SIDE PLATE	2
7	438710	BEARING CAP	2
8	438711	BEARING PLATE	2
9	438709	HANDLE	2
10	978028	FOAMITE STRIP 31.5" LONG	4
11	475106	CLEANOUT PIPE	4
12	475107	FLOOR FLANGE	4

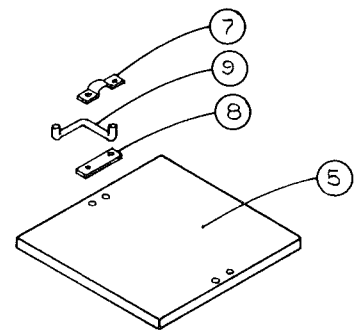
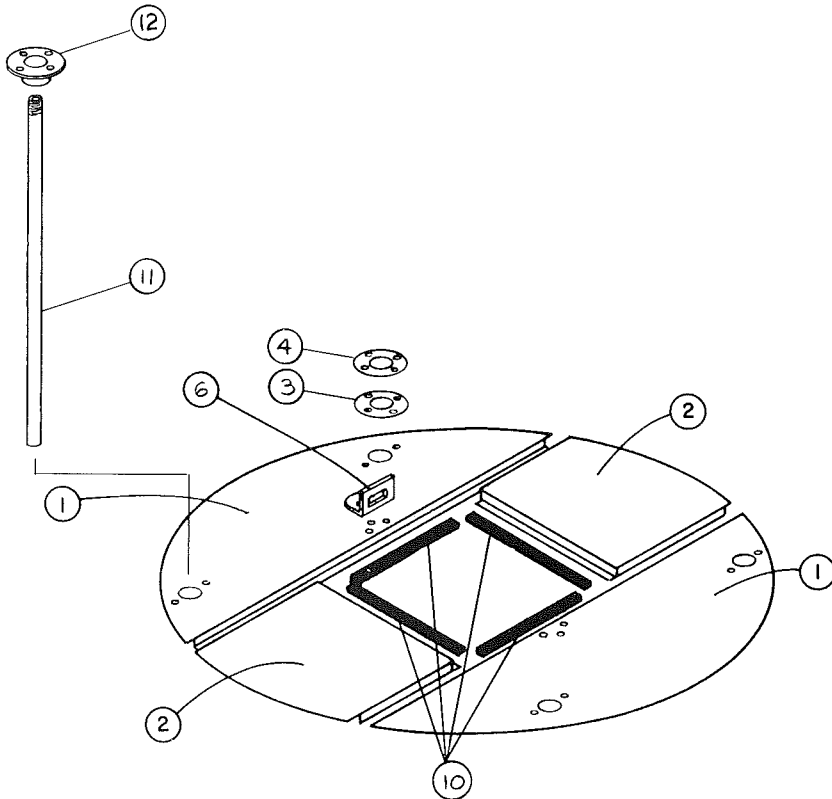

KS1349

# 3 HP DC MOTOR MOUNT

ITEM NO.	PART NO.	DESCRIPTION	QTY.
1	441021	SPACER, MOTOR MOUNT	2
2	441969	SWEEP MOTOR ATTACH. PLATE	1
3	475010	3 HP DC MOTOR	1
4	475236	1" J.A. BUSHING	1
5	475240	DRIVE PLATE, DC MOTOR WELDMENT	1
6	475235	PULLEY, 3 3/4" O.D.	1
7	475272	DECAL, CAUTION	1
8	475244	GUARD, BELT	1
9	475234	PULLEY, 6 1/2 O.D.	1
10	475237	BELT, DRIVE	1
11	475239	BEARING, JACK SHAFT, 1", AND COLLAR	2
12	475241	SHAFT, JACK 1" DIA.	1
13	837357	SHEAVE, 2.65 O.D.	1
14	475243	BELT TENSION ADJUSTING BRACKET	1
15	475246	1/4 x 1/4 x 1 1/2 KEY STOCK	3

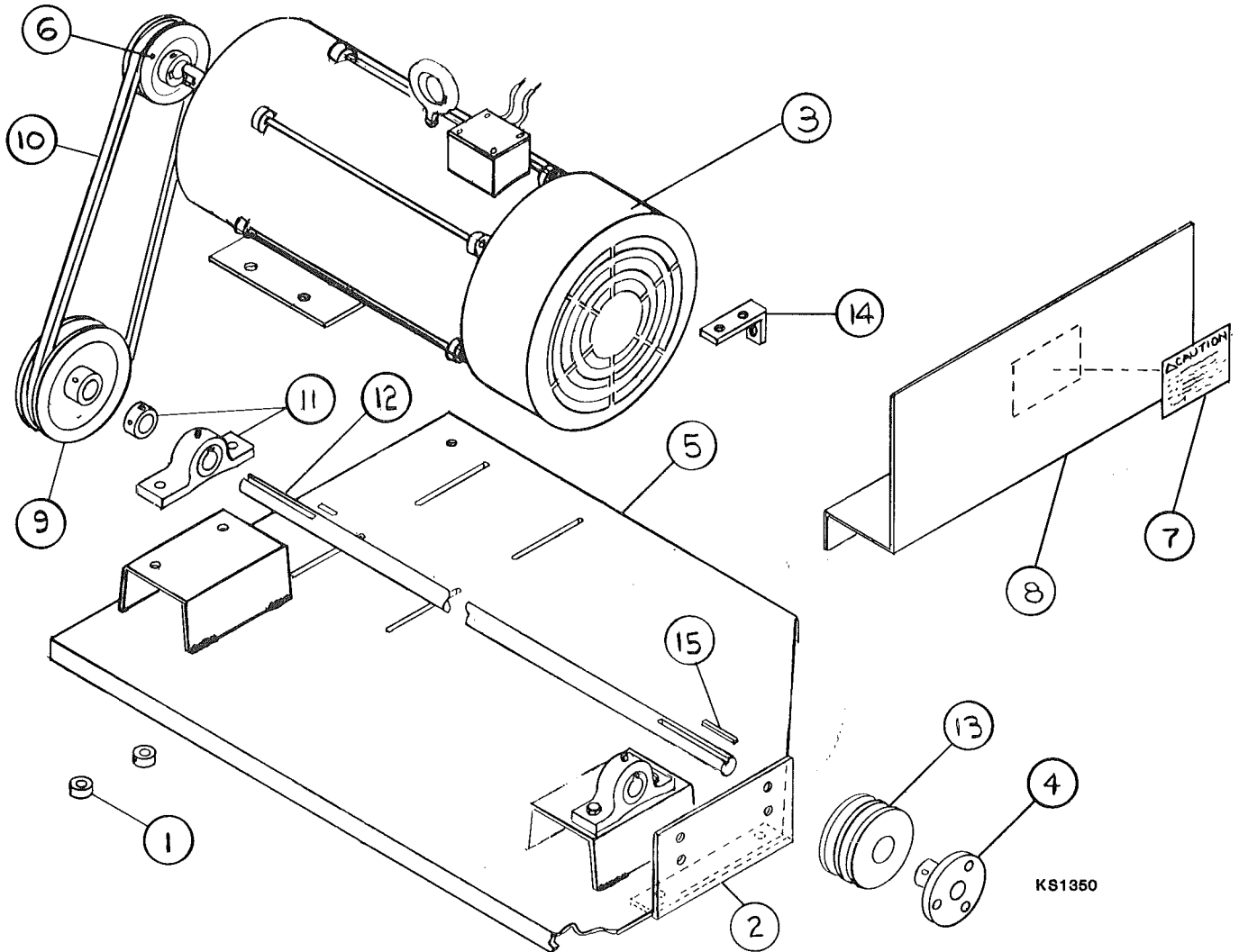



# FAN ASSEMBLY 10 & 15 HP

ITEM NO.	PART NO.	DESCRIPTION	QTY.	
			10 HP	15 HP
1	821576	MOTOR 10 HP	2	
	821577	MOTOR 15 HP		2
2	835253	BLADE ASS'Y (INCLUDES BUSHING)	2	
	835258	BLADE ASS'Y (INCLUDES BUSHING)		2
3	821316	VENTURI	2	2
4	833220	FAN GUARD (HALF)	4	4
5	821632	AIR SWITCH	2	2
6	837253	AIR SWITCH SAIL	2	2
7	834568	AIR SWITCH BRACKET	2	2
8	835184	TOP REPLACEMENT BEARING	2	2
9	835185	BOTTOM REPLACEMENT BEARING	2	2
10	444766	SLINGER	2	2

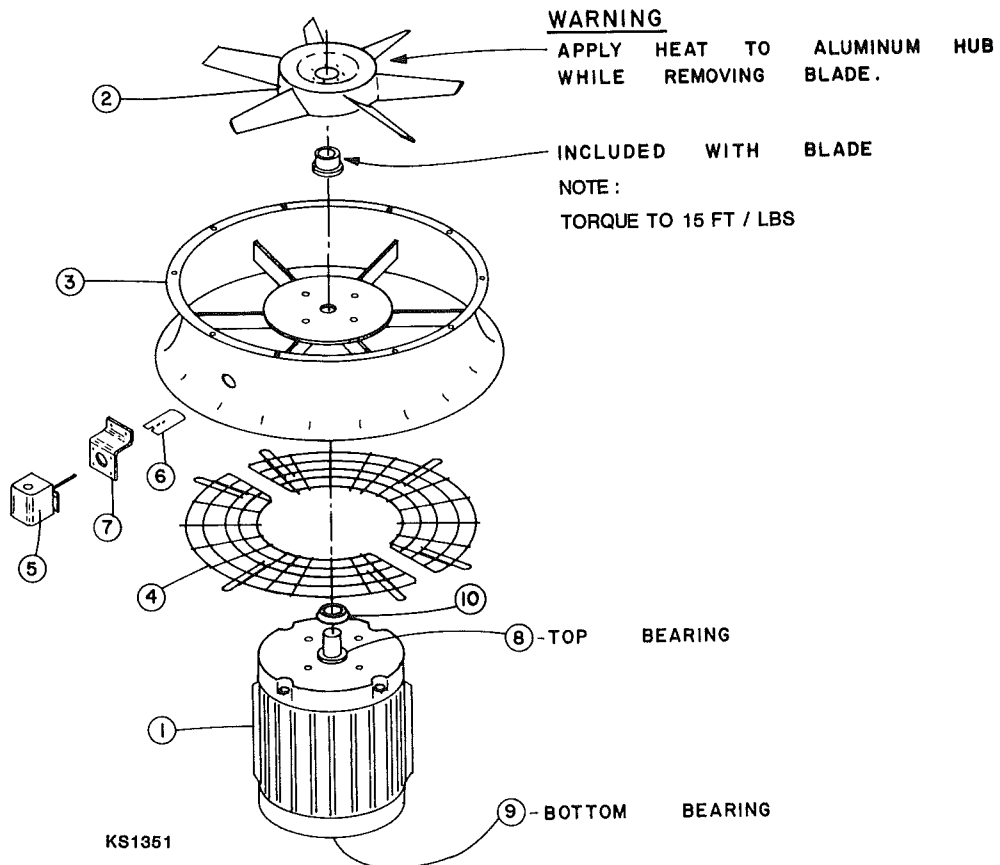

# BURNER

ITEM NO.	PART NO.	DESCRIPTION	QTY.
1	438499	BURNER SHELL	2
2	833224	AIR FIN	12
3	835368	BURNER SHIELD	2
4	835367	BURNER	2
5	837537	TINNERMAN CLIP	2
6	833745	AIR DAMPER	2
7	433888	LP ORIFICE 3/16 DIA.	2
	437168	LP ORIFICE 1/8 DIA. (LOW TEMP)	2
8	835366	PIPE	2
9	440105	BURNER RETAINER	4
10	441000	VAPORIZER BAFFLE ASSEMBLY	2
11	437082	UPPER VAPORIZER PIPE	2
12	437083	LOWER VAPORIZER PIPE	2
13	440929	ELBOW 1" 90° 300# BL	2
14	837248	STREET EL 1"-90° 300#	2
15	437119	VAPORIZER CLAMP	4
16	437118	VAPORIZER MOUNTING BRACKET	4
17	440106	BAFFLE END RETAINER	4
18	448064	PROBE CLIP	2
19	448068	FLAME CONTROL PROBE (LOCAL SENSE)	2
20	823551	HIGH TENSION LINE	2
21	823552	SECONDARY TENSION LINE	2
22	833468	BUSHING	4
23	833461	WIRE HOLDER	2
24	978389	FLAME MONITOR BOARD W/RESET	2
25	833524	FLAME MONITOR BRACKET	2
26	440917	VAPORIZER MOUNTING CLIP	4

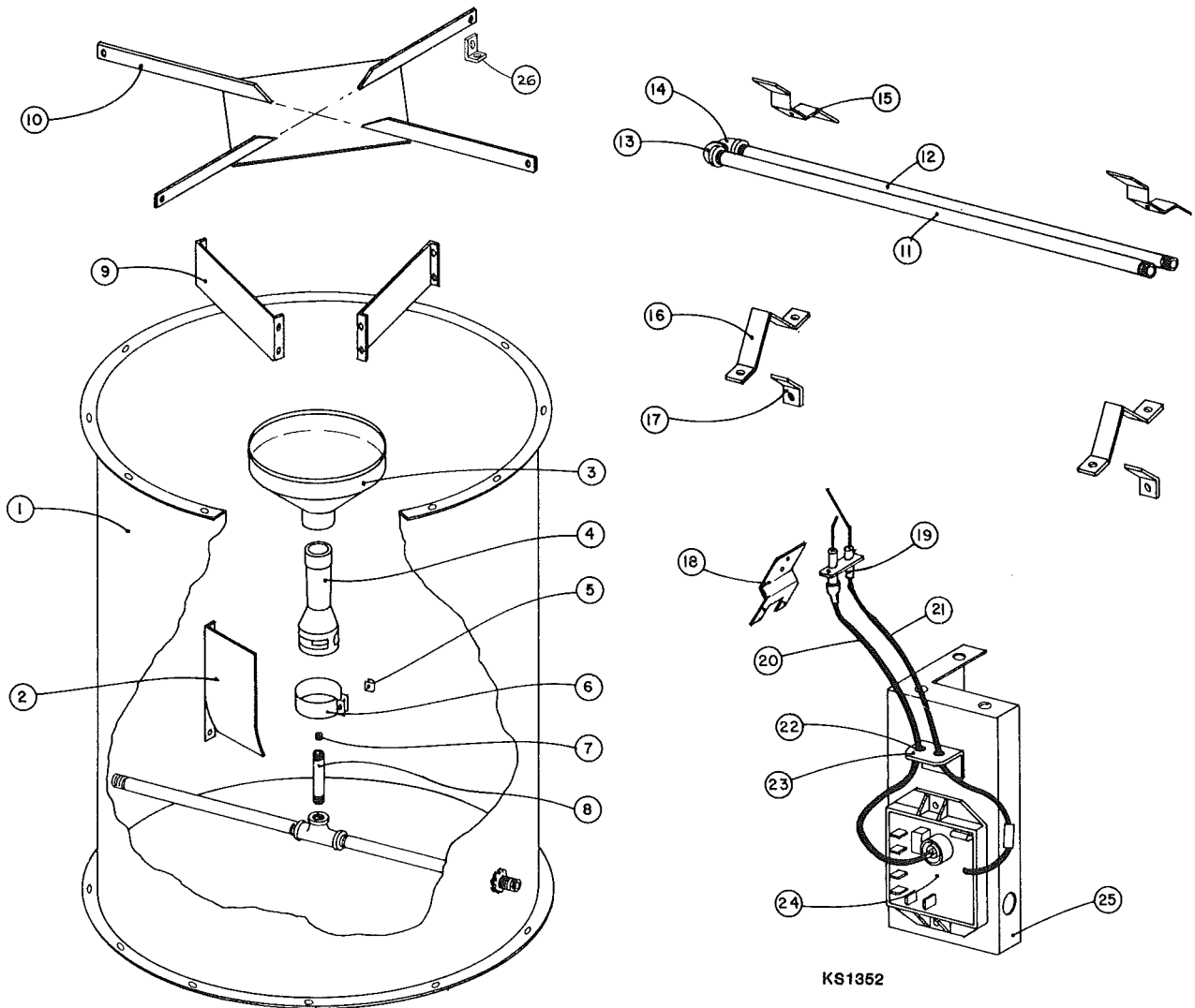

KS1352

# LP/NG PLUMBING ASSEMBLY

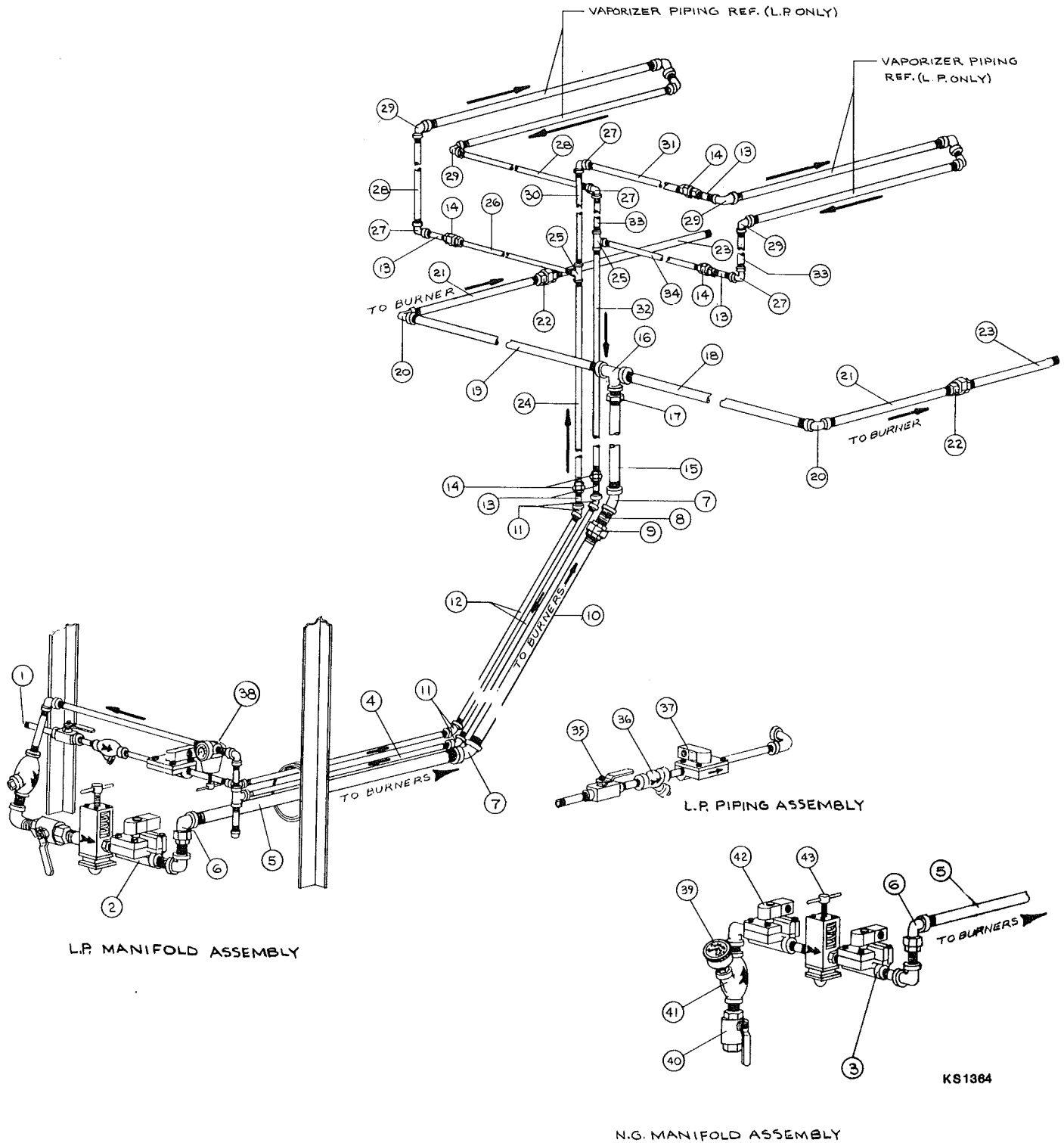

ALL PIPING MUST BE SCHEDULE 80 PIPE

# LP/NG PLUMBING ASSEMBLY

Ref.	Part No.	Qty.	Description	Ref.	Part No.	Qty.	Description
1	475099	1	LP Assembly	30	440812	1	½" x 18¼" Ex. Hvy. Nipple
2	475115	1	LP Manifold Ass'y	31	475114	1	½" x 5" Ex. Hvy. Nipple
3	475141	1	NG Manifold Ass'y	32	475221	1	½" x 40" Ex. Hvy. Nipple
4	475142	1	½" x 23¼" Ex. Hvy. Nipple	33	475142	2	½" x 23¼" Ex. Hvy. Nipple
5	475126	1	1" x 19" Ex. Hvy. Nipple	34	475143	1	½" x 10" Ex. Hvy. Nipple
6	475128	1	1" x 90° Ex. Hvy. Union Elbow	35	823387	1	½" Hand Valve (LP only)
7	475129	2	1" x 45° Ex. Hvy. Elbow	36	823297	1	½" Strainer (LP only)
8	475119	1	1" Close Ex. Hvy. Nipple	36A	837657	1	Replacement Screens ½"
9	475130	1	1" Ex. Hvy. Union	37	465554	1	½" Solenoid Valve (LP only)
10	475127	1	1" x 19½" Ex. Hvy. Nipple	37A	834656	1	Replcmnt. Diaphragm Assembly
11	475125	4	½" x 45° Ex. Hvy. Elbow	37B	833618	1	Replacement Coil
12	475124	2	½" x 24½" Ex. Hvy. Nipple	38	445521	1	½" Gas Regulator (LP only)
13	096370	5	½" x 1½" Ex. Hvy. Nipple	39	445520	1	0-60 PSI Pressure Gauge
14	096384	5	½" Ex. Hvy. Union	40	822284	1	1" Hand Valve
15	475132	1	1" x 43" Ex. Hvy. Nipple	41	823293	1	1" Strainer
16	475135	1	¾" x ¾" x 1¼" Tee	41A	837659	1	Replacement Screen 1"
17	475131	1	1¼" to 1" Red Bushing	42	465556	1	1" Solenoid Valve
18	475133	1	¾" x 10" Ex. Hvy. Nipple	42A	475309	1	Replcmnt. Diaphragm Ass'y
19	475134	1	¾" x 19½" Ex. Hvy. Nipple	42B	475310	1	Replacement Coil
20	475136	2	¾" x 90° Ex. Hvy. Elbow	43	437086	1	1" Modulating Valve
21	833708	2	¾" x 8" Ex. Hvy. Nipple	43A	437214	1	Replacement Power Element 140-250
22	475137	2	¾" Ex. Hvy. Union	43B	437215	1	Replcmnt. Diaphragm Kit
23	438659	2	¾" x 13-3/8" Ex. Hvy. Nipple	43C	437216	1	Replacement Valve & Seat Kit
24	475138	1	½" x 48" Ex. Hvy. Nipple	*	837524	4	5/16-18 x 3/4" HWHCS Whiz
25	096357	2	½" Ex. Hvy. Tee	*	434632	4	5/16-18 Whiz Hex Nut
26	440957	1	½" x 20" Ex. Hvy. Nipple	*	834038	8	¼-20 Whiz Locknut
27	096360	4	½" x 90° Ex. Hvy. Elbow	*	436359	4	U Bolt/½" Pipe
28	475139	2	½" x 17½" Ex. Hvy. Nipple	*	436349	2	LP-NG Piping Brkt.
29	440930	4	1" to ½" 90° Ex. Hvy. Elbow	*	437081	1	NG Mtg. Channel

\*Items not shown.

# CONTROL PANEL CABINET

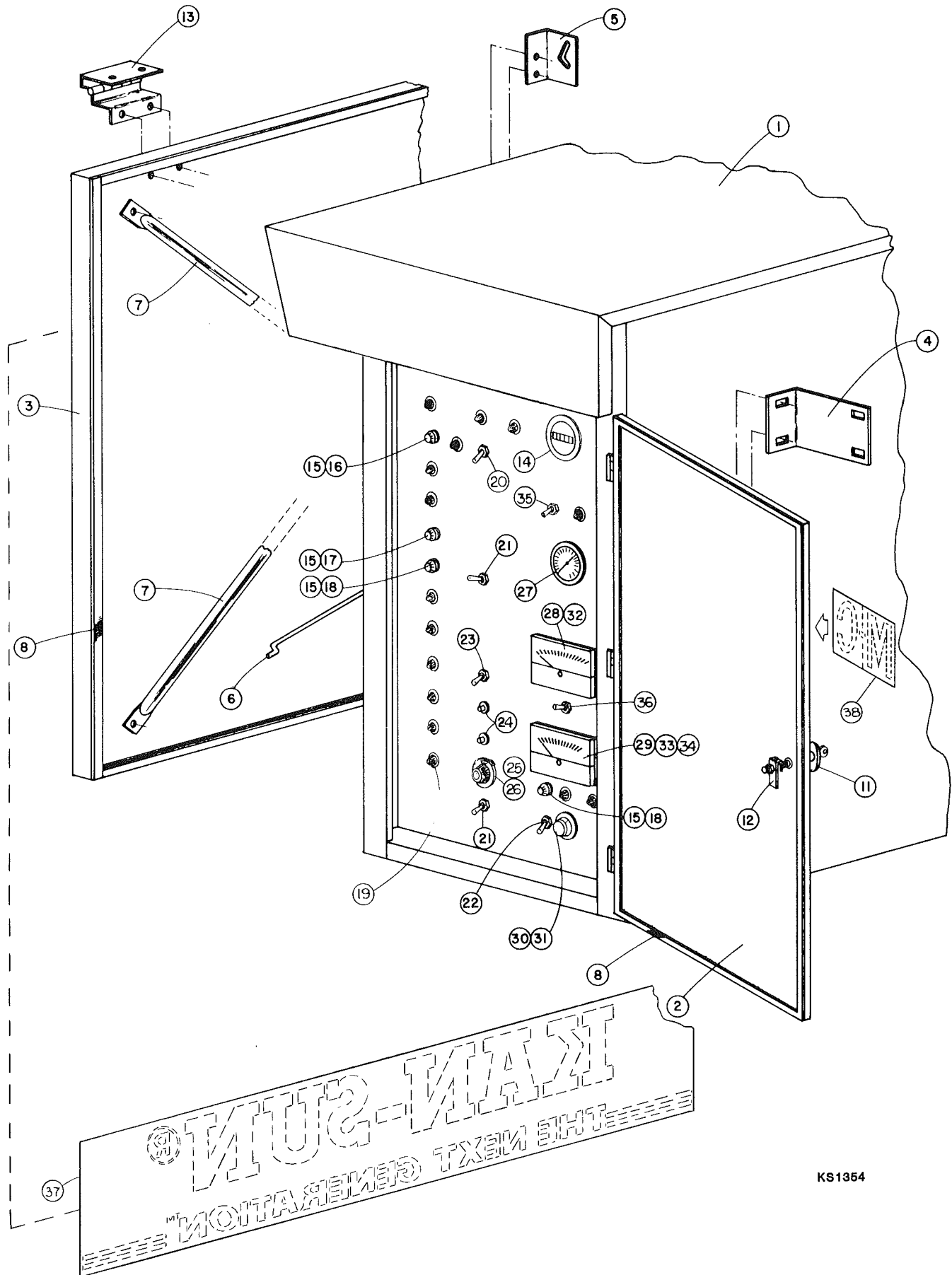

KS1354

# CONTROL PANEL PARTS LIST

ITEM NO.	PART NUMBER	DESCRIPTION	QTY
1	475020	CONTROL BOX WELD ASSEMBLY	1
2	445690	CONTROL DOOR COVER WELD ASSEMBLY	1
3	448109	CONTROL BOX COVER	1
4	836894	CONTROL BOX MOUNTING BRACKET	4
5	445507	DOOR SUPPORT BRACKET	1
6	445509	DOOR SUPPORT ROD	1
7	445527	CROSS BRACE	2
8	436448	GASKET STRIP (30" LONG)	AS REQ'D.
9	445508*	DOOR SUPPORT ROD PIVOT MOUNT	1
10	420005*	COVER DOOR SLOT	2
11	444589	LOCKING "T" HANDLE	3
12	433800	LOCKING CAM	3
13	444628	HINGE	2
14	444645	HOUR METER	1
15	433100	FUSE HOLDER	4
16	423336	FUSE (5 AMP)	1
17	444613	FUSE (1/2 AMP)	1
18	833447	FUSE (1 AMP)	2
19	475016	PILOT LAMP ASSEMBLY	15
20	475300	START UP-RUN SWITCH	1
21	433658	START-STOP SWITCH	2
22	475194	AUTO-MANUAL SWITCH	1
23	438907	BURNER ON-OFF SWITCH	1
24	441959	REMOTE RESET SWITCH	2
25	475013	10 TURN POTENTIOMETER	1
26	475014	SPEED CONTROL DIAL	1
27	475015	TEMPERATURE GAUGE	1
28	444782	GRAIN TEMPERATURE METER (GASKET #475269)	1
29	444783	DISCHARGE SPEED METER (GASKET #475269)	1
30	438698	POTENTIOMETER	1
31	438699	KNOB	1
32	445961	TEMPERATURE BRIDGE	1
33	475191	1 MEG OHM RESISTOR	1
34	475192	806K RESISTOR	1
35	475263	AUTOMATIC-OFF-MANUAL SWITCH	1
36	475194	COLD-HOT SWITCH	1
37	475182	DECAL "KAN-SUN - THE NEXT GENERATION"	1
38	475273	DECAL "M-C"	1

\* ITEMS NOT SHOWN

KS1354

# ELECTRICAL COMPONENTS

ITEM NO	PART NO.	DESCRIPTION	QTY
1	438642	CONTACTOR 30AMP-3POLE (3HP METER MOTOR)	1
2	835916	HIGH LIMIT CONTROL 10FT LEAD	1
3	837700	HEATER STRIP (10HP FAN MOTOR) 220V 1 PHASE	3
	837699	HEATER STRIP (15HP FAN MOTOR) 220V 1 PHASE	3
4	437052	FAN MOTOR STARTER (10 & 15 HP) 220V 1 PHASE	2
5	444603	LOW TEMPERATURE THERMOSTAT	1
6	444511	POWER DISTRIBUTION BLOCK (3 POLE)	1
7	442533	TIME DELAY RELAY (6 SEC.)	—
8	835872	TERMINAL BLOCK	1
9	475012	TERMINAL GROUNDING BLOCK (4 POSITION)	1
10	837102	TRANSFORMER	1
11	447262	FUSE-4 AMP	2
12	446047	FUSE BLOCK	1
13	431155	AUXILIARY	4
14	434822	GROUND LUG	1
15	475009	MOISTURE CONTROL BOARD II	1
16	475008	SCR BOARD	1
17	445960	8 VOLT POWER SUPPLY	1
18	444614	TIME DELAY RELAY (15 SEC.)	1
19	444615	SQUARE BASE RELAY SOCKET	1
20	475202	SCR FUSE	2

ITEM NO	PART NO	DESCRIPTION	QTY
22	837672	HEATER STRIP (10HP FAN MOTOR) 220V 3 PHASE	3
	837673	HEATER STRIP (15HP FAN MOTOR) 220V 3 PHASE	3
23	437051	FAN MOTOR STARTER (10 & 15 HP) 220V 3 PHASE	2
24	475189	.1 TO 8 MINUTE TIMER	1
25	475261	0 TO 60 MINUTE TIMER	1
26	475262	TIMER SOCKET	1
27	475311	MAIN RELAY	1
28	475312	RELAY SOCKET	1
29	475313	FILL RELAY	1
30	446160	DELAY OFF RELAY	1

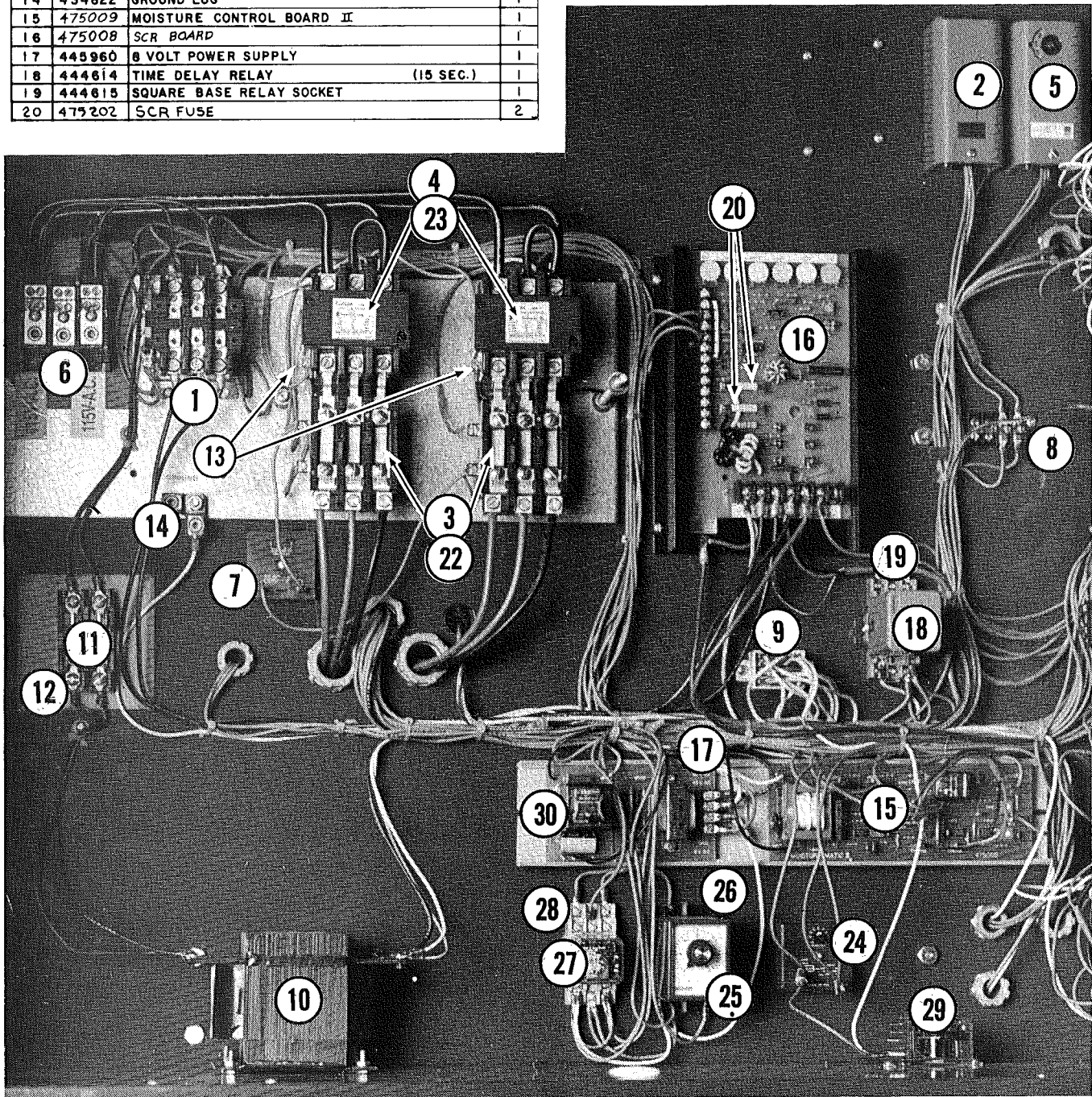

# THERMISTORS

ITEM NO.	PART NO.	DESCRIPTION	QTY.
1	438700	THERMISTOR (STANDARD)	8
2	095180	8-18 x 1/2 PAN HD. SELF TAP SCREW	12
3	475195	THERMISTOR BOX - 1 WAY	5
4	475196	THERMISTOR BOX - 3 WAY	1
5	435507	THERMISTOR BOX COVER	6
6	475275	THERMISTOR BOX - 4 WAY	1
7	475176	STRAIN RELIEF CONNECTOR	8
8	439553	1/2" CONDUIT LOCKNUT	8
9	475280	TERMINAL BOX, DRILLED	1
10	475175	5/16" ALUMINUM CONDUIT	1

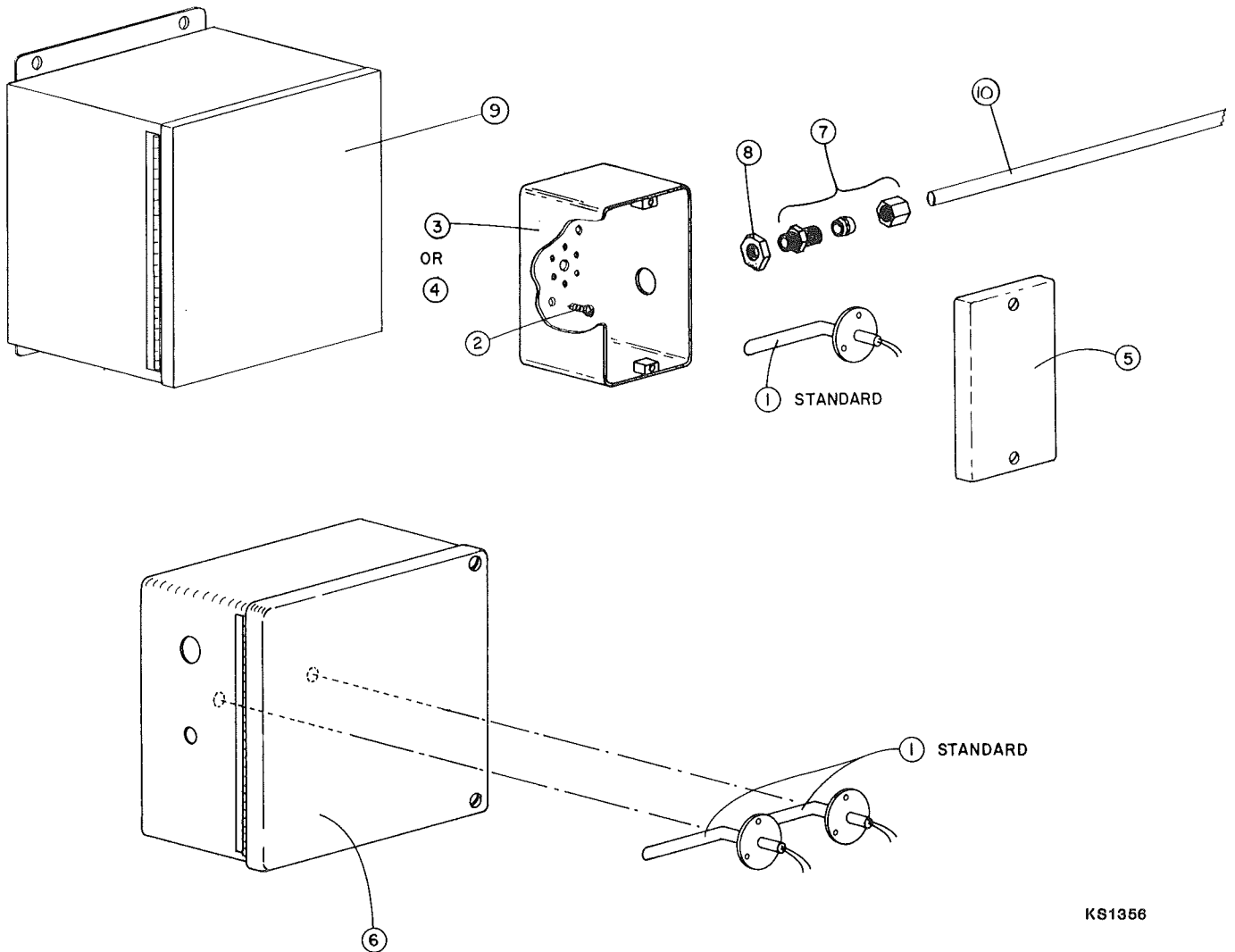

KS1356



# THERMISTOR CHART

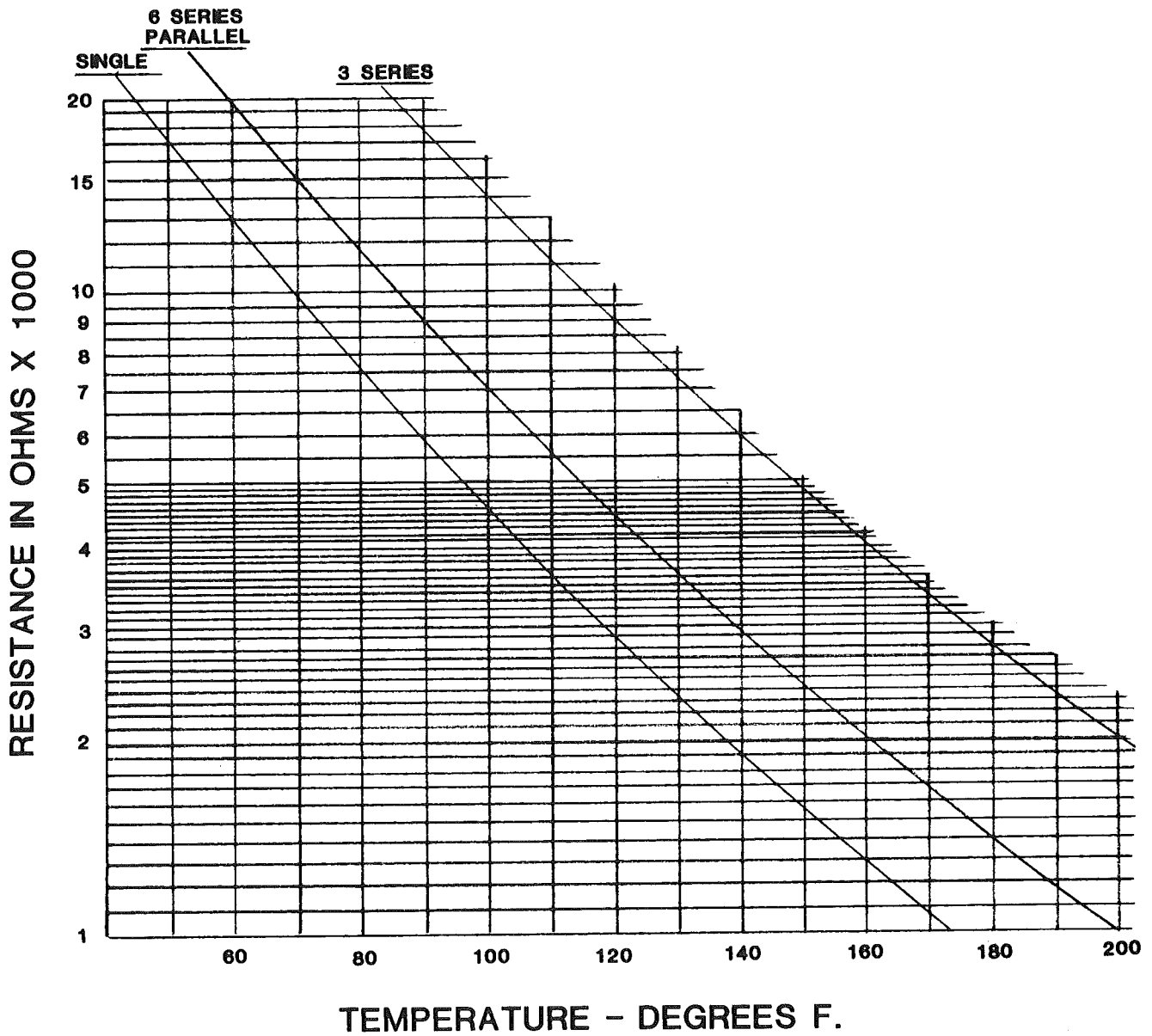
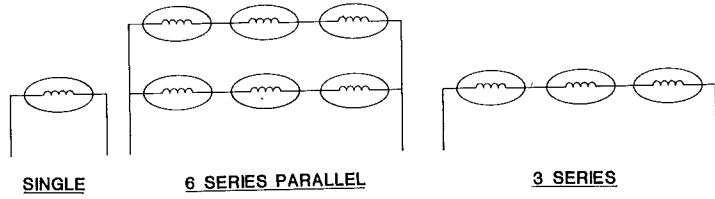

KS1367

# PHASE CONVERTOR

ITEM NO.	PART NO.	DESCRIPTION	QTY.	
			10 HP	15 HP
1	475253	BOX	1	1
2	475256	CAPACITOR HOLD DOWN	1	2
3	475257	INSULATOR, RESISTOR	1	1
4	837526	RESISTOR	1	1
5	475224	CAPACITOR HOLD DOWN STRAP	1	2
6	837527	TERMINAL BOARD	1	1
7	833500	RELAY	1	1
8	430885	CAPACITOR (ELECTROLITIC) 216 MFD	2	3
9	430886	CAPACITOR (OIL) 20 MFD	5	9
10	820796*	10HP PHASE CONVERTOR	1	-
11	821420*	15HP PHASE CONVERTOR	-	1
12	833411	BRACKET, PHASE BOX MOUNTING	4	4
13	475255	COMPONENT MOUNTING PLATE	1	1
14	475259*	RUBBER SPONGE INSULATION		
15	475260	BRACKET, TERMINAL BOARD	1	1
16	833700	BRACKET, HOLD DOWN	1	-

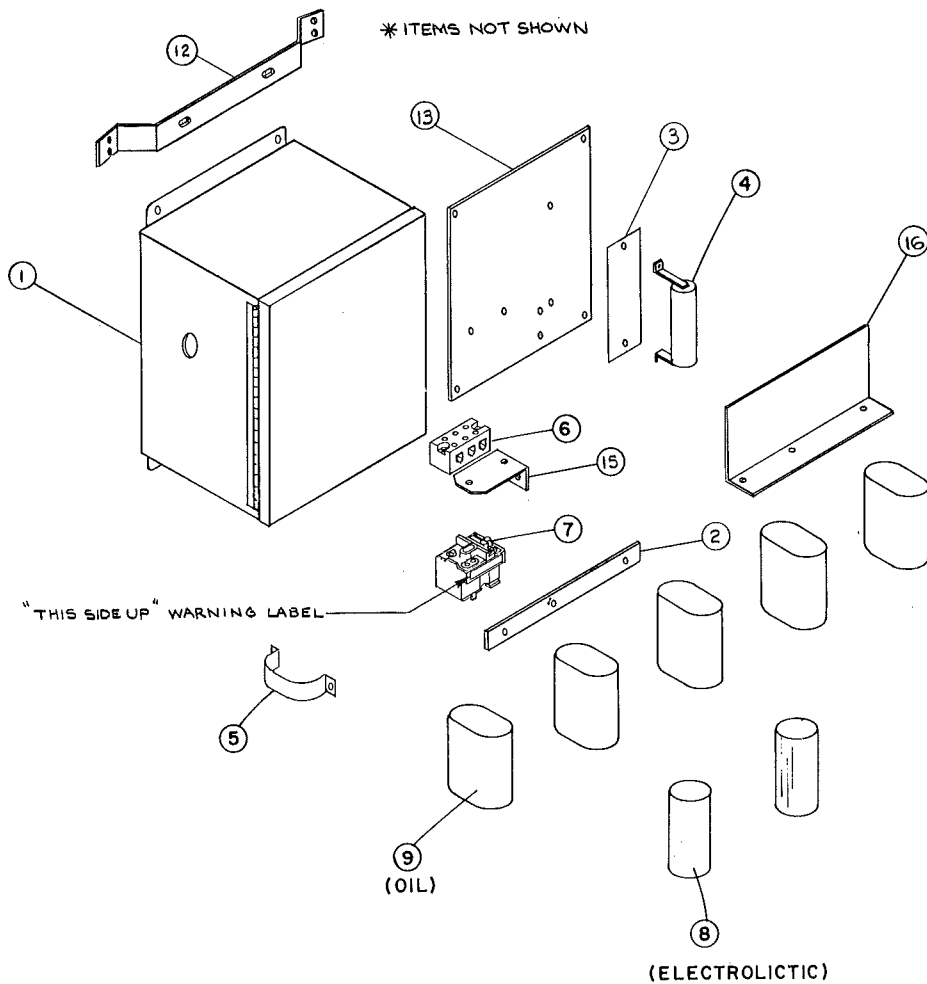

KS1357

# 10' ROOF SECTION

REF. NUMBER	PART NUMBER	QUANTITY	DESCRIPTION
1	833219	2	RING, TRANSITION
2	834721	4	CLIP, FILLER M480
3	441551	16	REIN CHANNEL 10'KS ROOF
4	439780	16	INNER PERF PEAK PANEL 10'
5	439063	1	ROOF CAP M001
6	830109	1	U-BOLT, ROOF CAP M021
7	438649	2	TAB OUTER RING BOLTING
8	438761	2	OUTSIDE CHANNEL RING
9	475028	4	WET HOLDING BIN SCREEN
10	475026	2	OUTER 10' TRANSITION RING
11	475027	16	OUTER ROOF PANEL
12	475029	(B) 32	UNIVERSAL ANGLE
13	475092	1	GRAIN RECEIVING ASSEMBLY
(B) 14	475252	2	OUTER ROOF CHANNEL RING
(B) 15	833353	2	TAB INNER RING BOLTING

ROOF SECTION

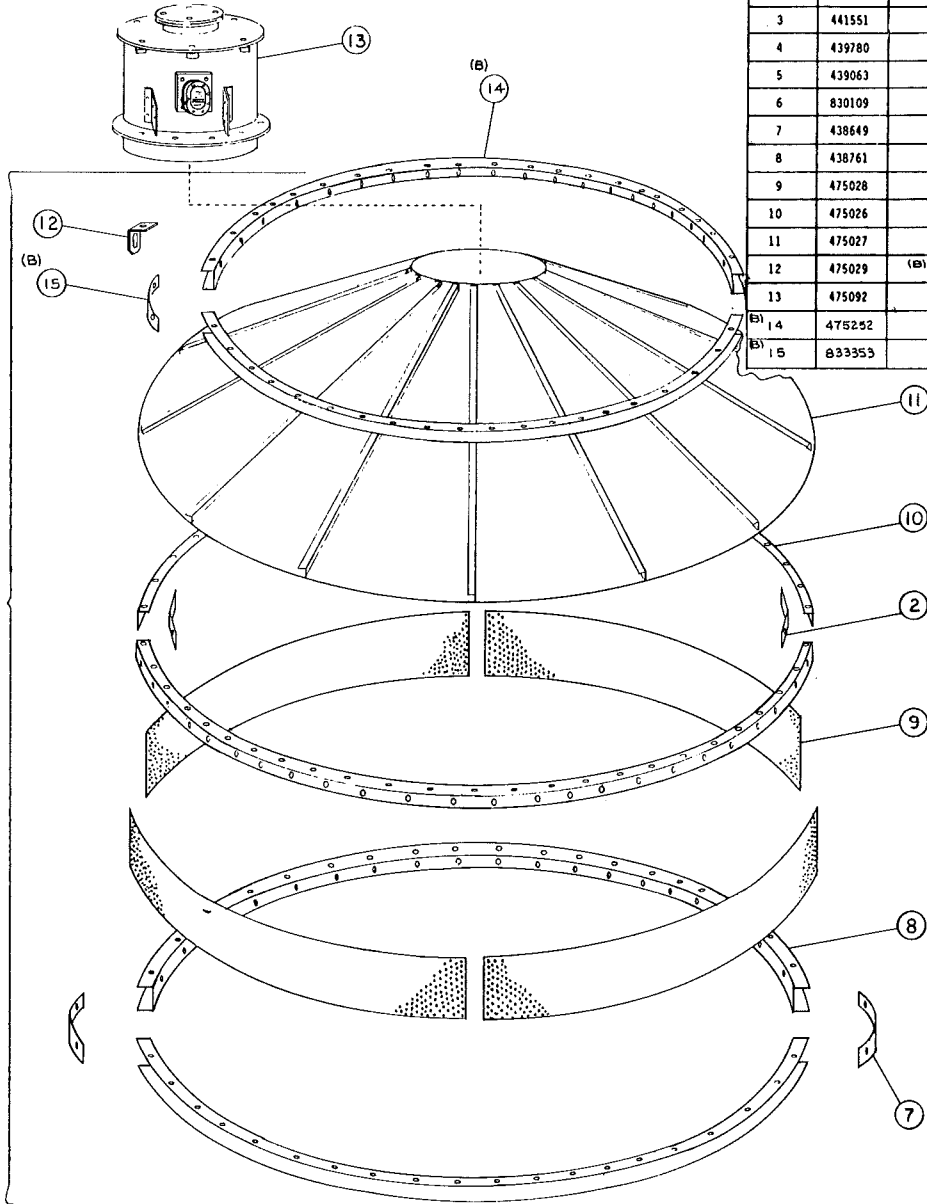

(B)  
INNER PEAK  
FOR PURPOSES OF BILL OF MATERIALS  
ITEMS #1 THRU ITEM #6 ARE  
COMPONENTS OF ASSEMBLY # 822213

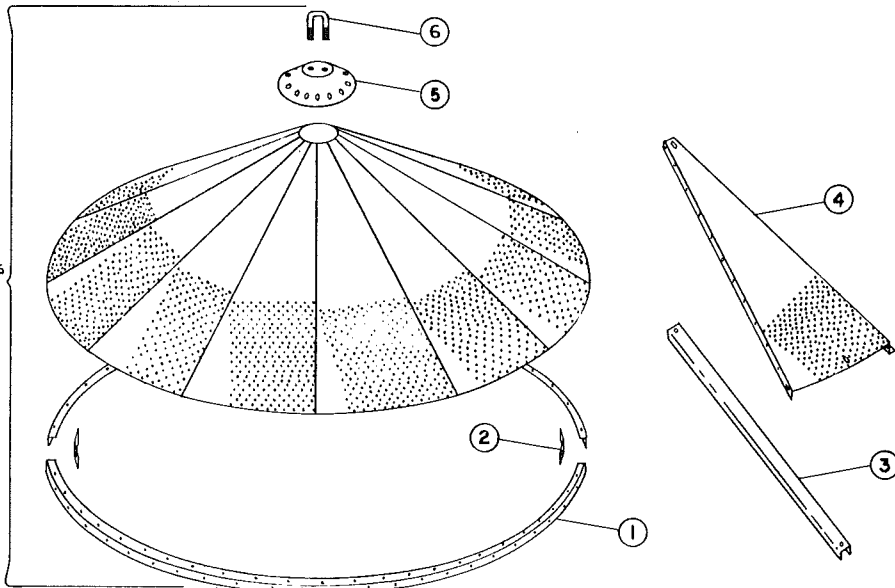

KS1362

# GRAIN RECEIVING TOP ASSEMBLY

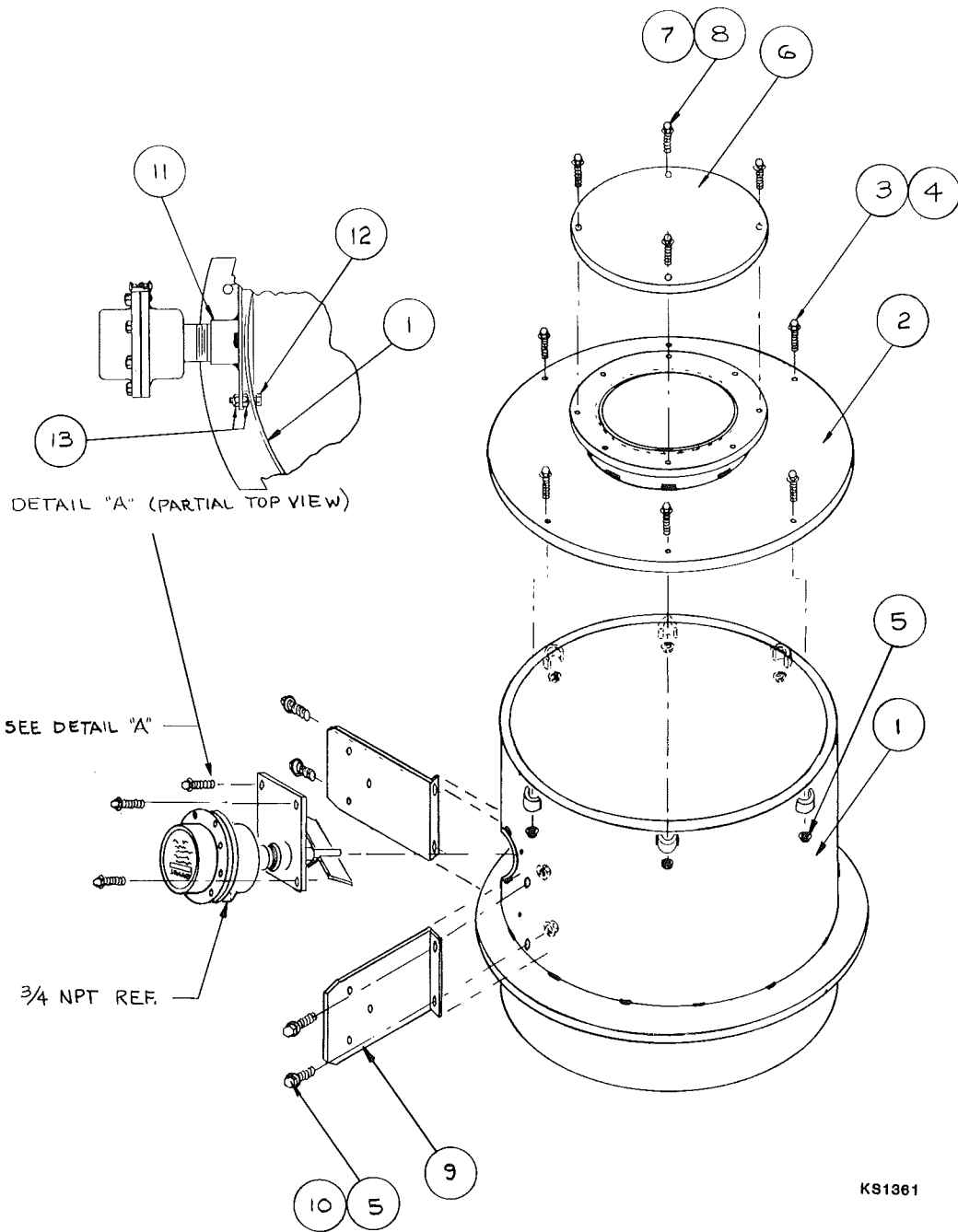

Ref.	Part No.	Qty.	Description
1	475030	1	Grain Receiving Weld.
2	475091	1	Receiving Tube Weld.
3	475094	6	3/8-16 x 2" HHCS
4	095013	6	3/8 Flat Washer
5	434111	10	3/8-16 Whiz Hex Nut
6	475037	1	Receiving Tube Cover
7	837524	4	5/16-18 x 3/4" HWHCS Whiz

Ref.	Part No.	Qty.	Description
8	434632	4	5/16-18 Whiz Hex Nut
9	475058	2	Ladder to Fill Mount
10	095078	4	3/8-16 x 3/4" HHCS
11	475232	1	Rotary Fill Switch Ass'y
12	095058	4	1/4-20 x 1 1/2" HHCS Gr.5
13	834038	8	1/4-20 Whiz Hex Locknut

# LADDER ASSEMBLY

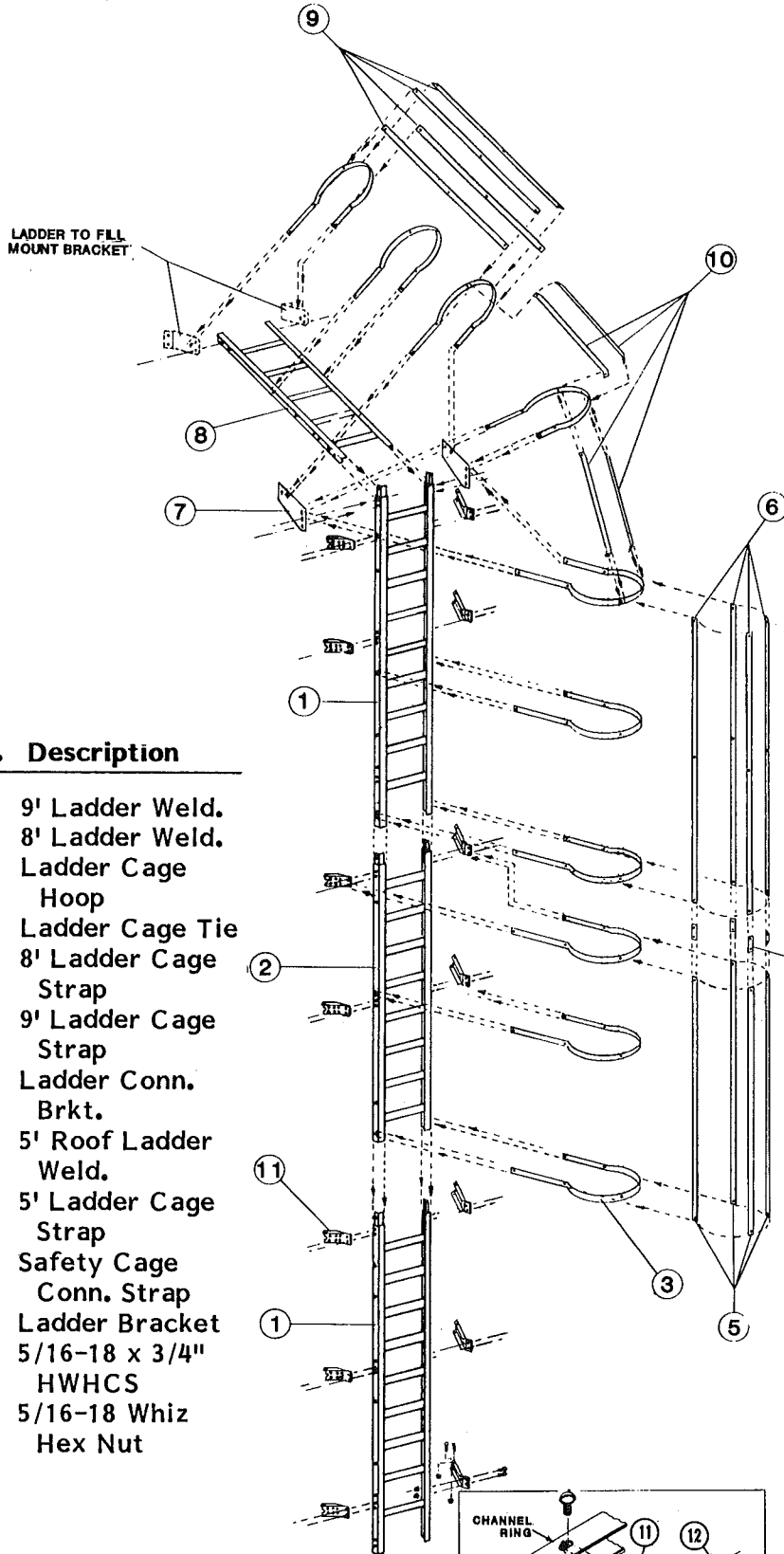

Ref.	Part No.	Qty.	Description
------	----------	------	-------------

1	475061	2	9' Ladder Weld.
2	475062	1	8' Ladder Weld.
3	475063	10	Ladder Cage Hoop
4	475064	4	Ladder Cage Tie
5	475066	4	8' Ladder Cage Strap
6	475065	4	9' Ladder Cage Strap
7	475059	2	Ladder Conn. Brkt.
8	475060	1	5' Roof Ladder Weld.
9	475067	4	5' Ladder Cage Strap
10	475090	4	Safety Cage Conn. Strap
11	475081	14	Ladder Bracket
12	837524	110	5/16-18 x 3/4" HWHCS
13	434632	110	5/16-18 Whiz Hex Nut

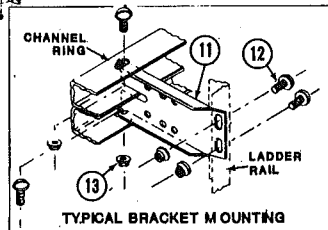
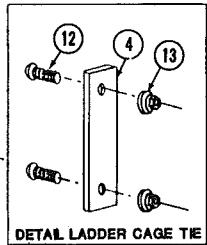

K81371

# 460 VOLT ELECT. COMPONENTS

REF	PART NO.	DESCRIPTION	QTY
1	475220	TRANSFORMER MOUNT	1
2	475218	460 VOLT TRANSFORMER	1
3	475207	INSULATOR PLATE	1
4	475208	INSULATOR PLATE	1
5	475217	70AMP 2 POLE FUSEHOLDER	1
6	475219	INSULATOR, FUSEHOLDER	1
7	475204	35 AMP FERRULE FUSE	2
8	437051	MOTOR, STARTER	1
9	436821	HEATER STRIP (10 HP METER MOTOR, FURNAS E57)	3
	436822	HEATER STRIP (15 HP METER MOTOR, FURNAS E62)	3

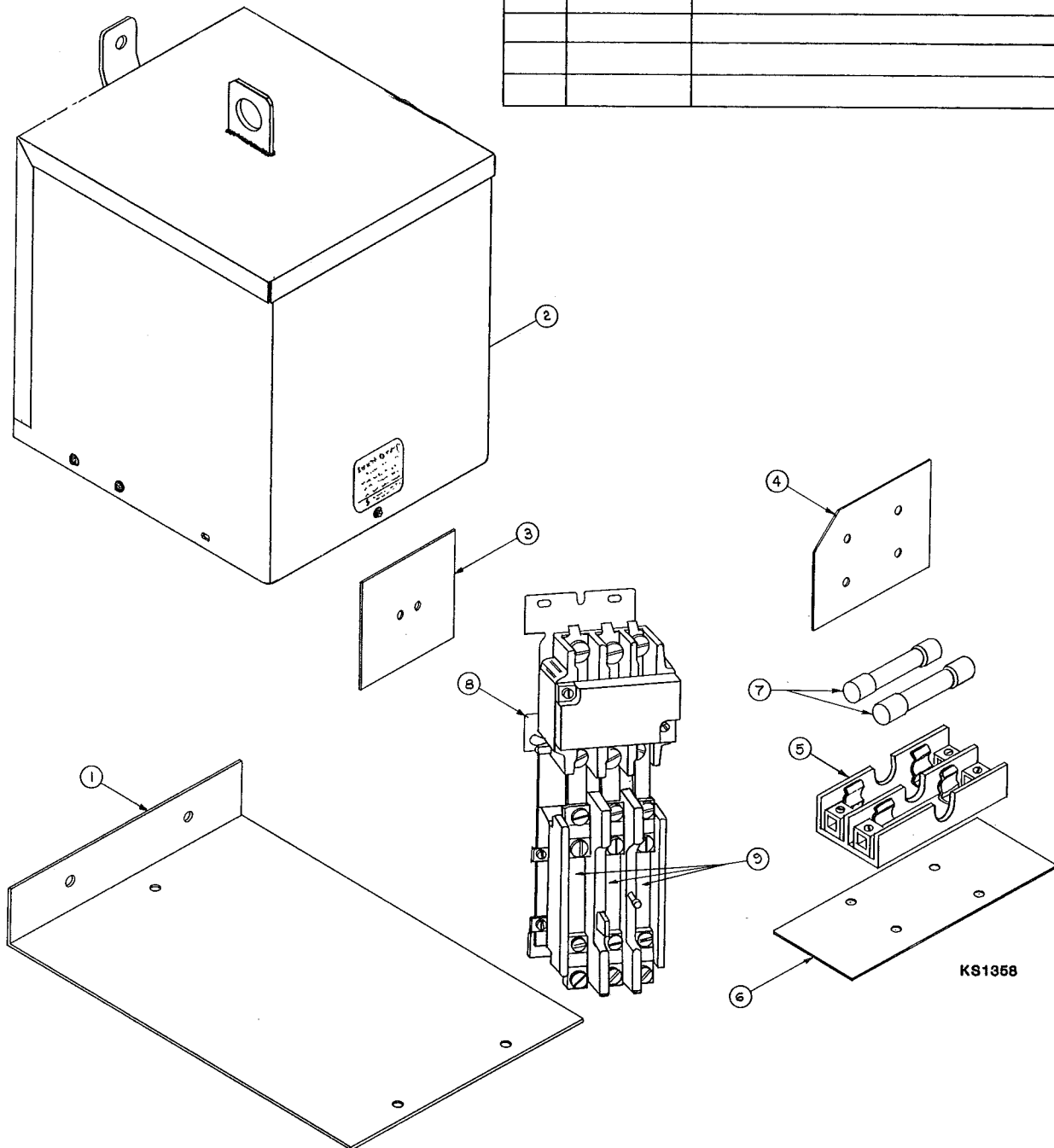

# PHASE CONVERTER WIRING DETAILS

230 VAC - 1 PHASE 10 OR 15 HP.

**NOTES:**

- 1) OBSERVE "THIS SIDE UP" WARNING LABEL ON RELAY WHEN MOUNTING
- 2) TO REVERSE ROTATION INTERCHANGE 1 AND 10

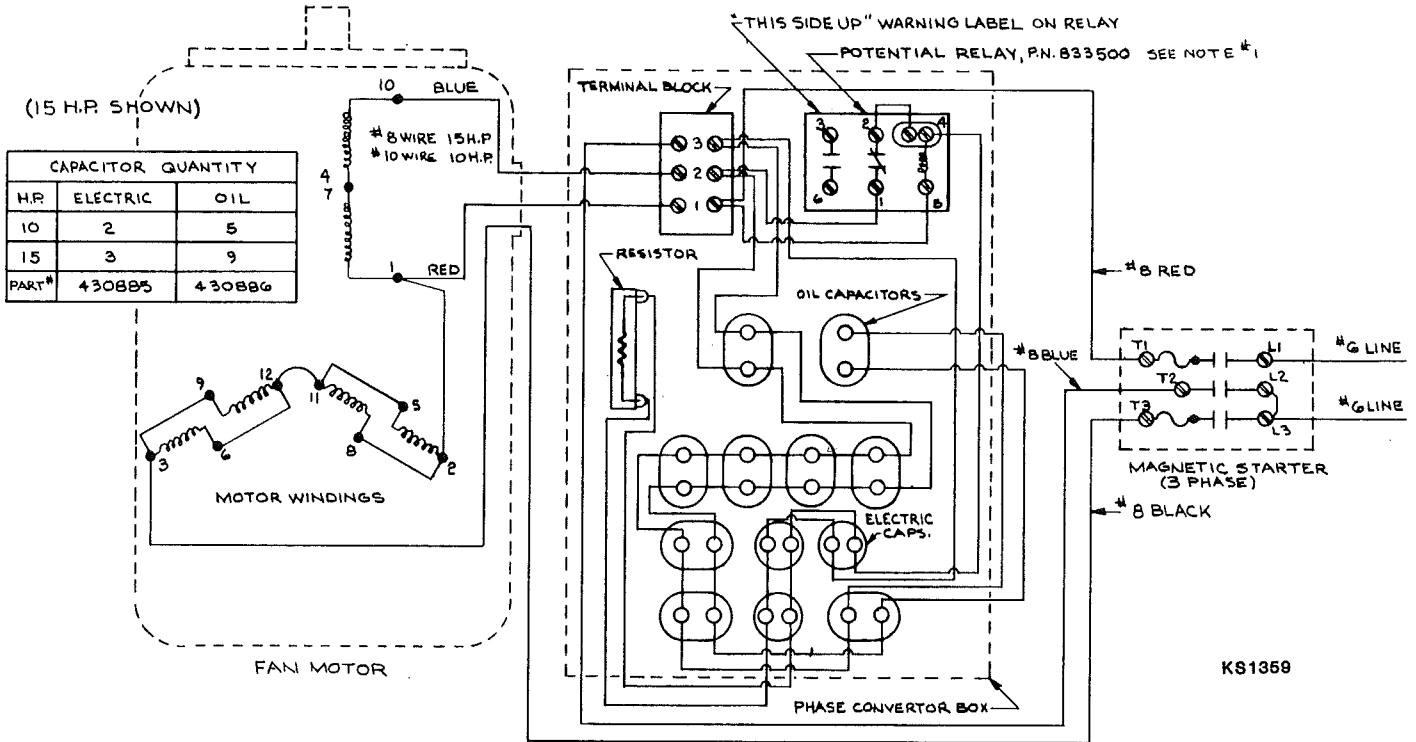

## MOTOR - TRANSFORMER WIRING DETAILS

460 VAC-3PH. 10 OR 15 HP.

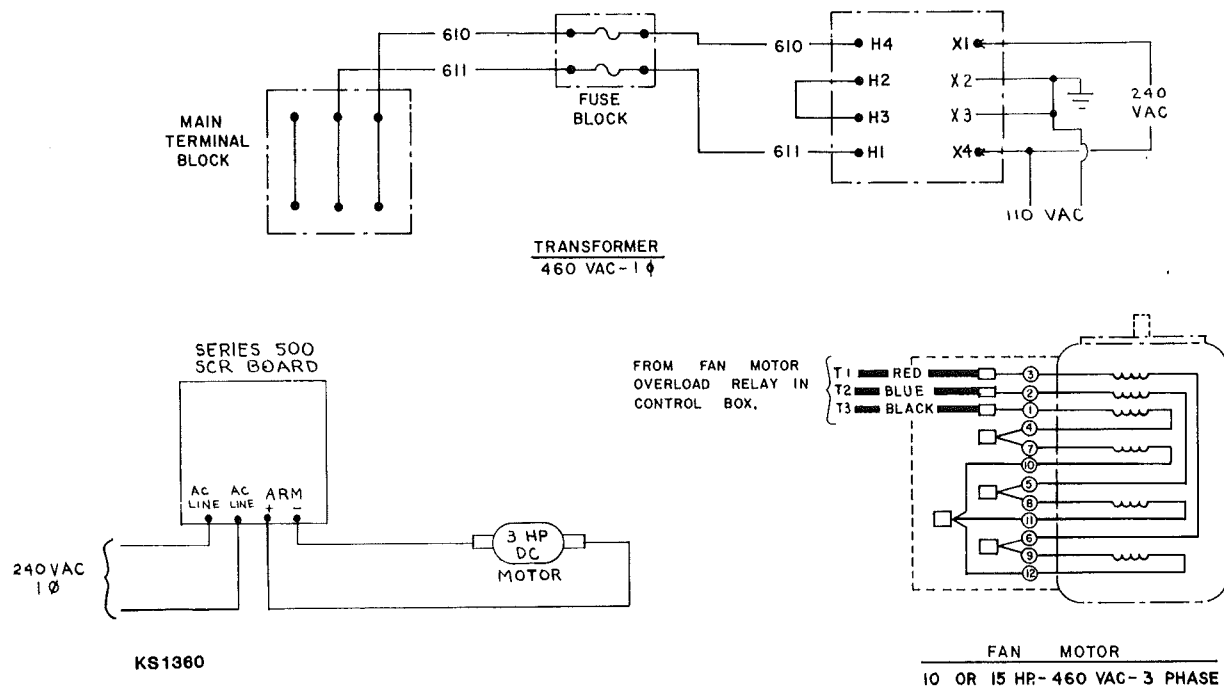

# 230 VOLT MOTOR WIRING

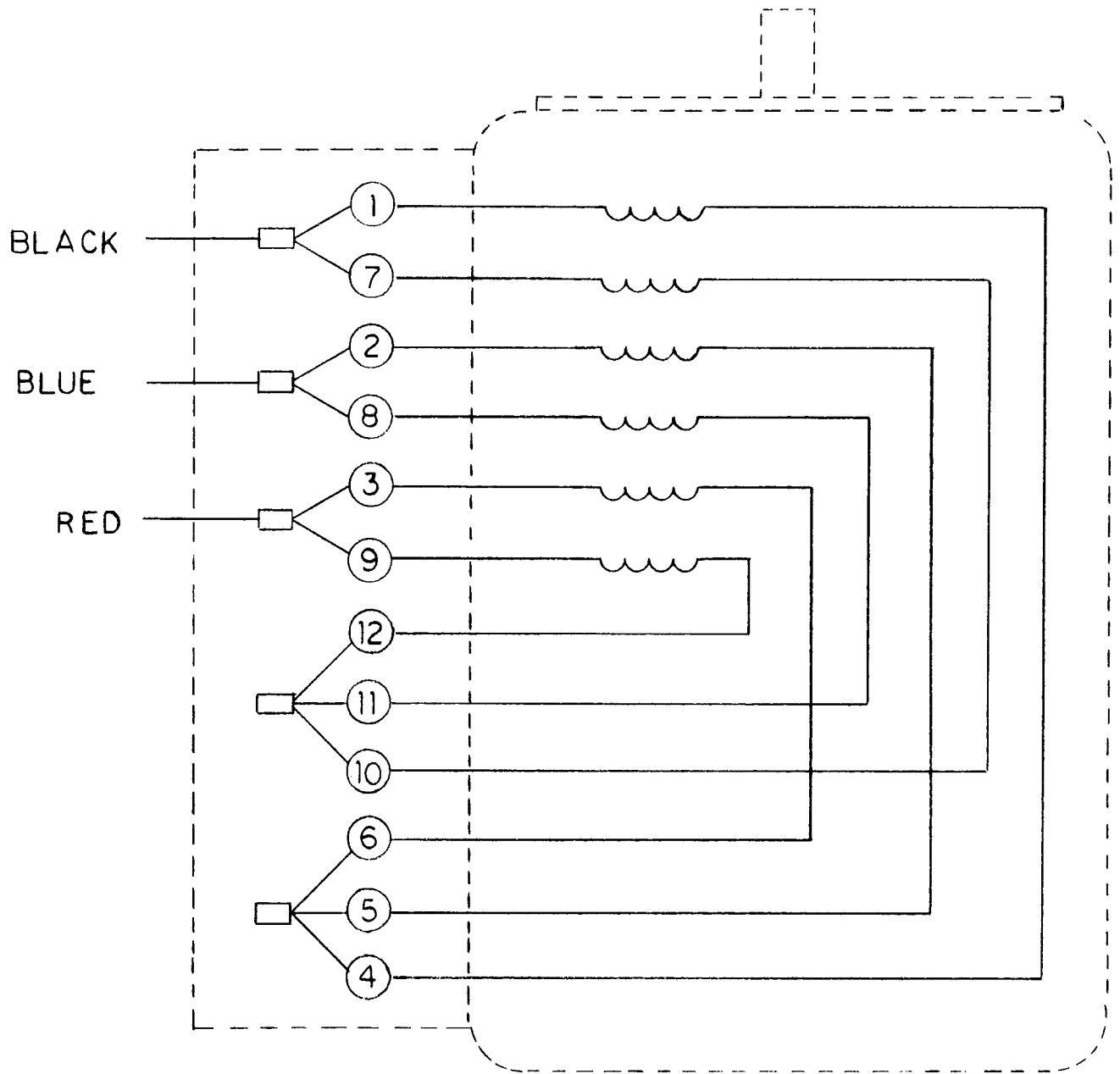

KS1369

BALDOR 10-15 HP - 230 VAC - 3 PH



# KAN-SUN MOISTURE-MATIC® II BOARD

## DEADBAND ADJUSTMENT

Locate the deadband adjustment potentiometer on the Moisture-Matic® II board.

With a small screwdriver, adjust the potentiometer (R-7) until both plus (+) and minus (-) lights stay off when turning the moisture control dial two spaces on the scale.

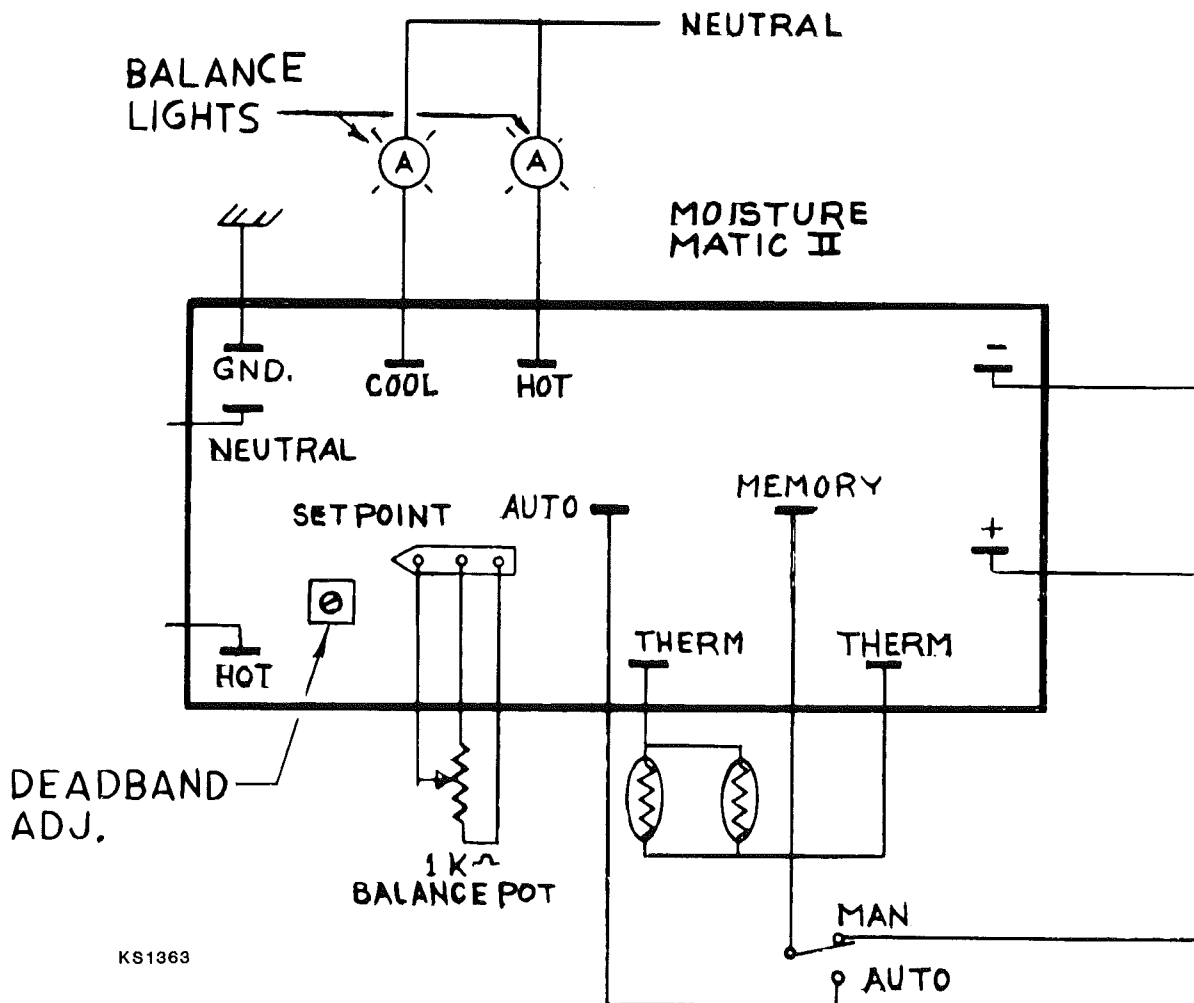

KS1363

# DIMENSION DATA

In temporary installations and in areas where blow over may occur due to wind the dryer should be guy wired, typically in three places.

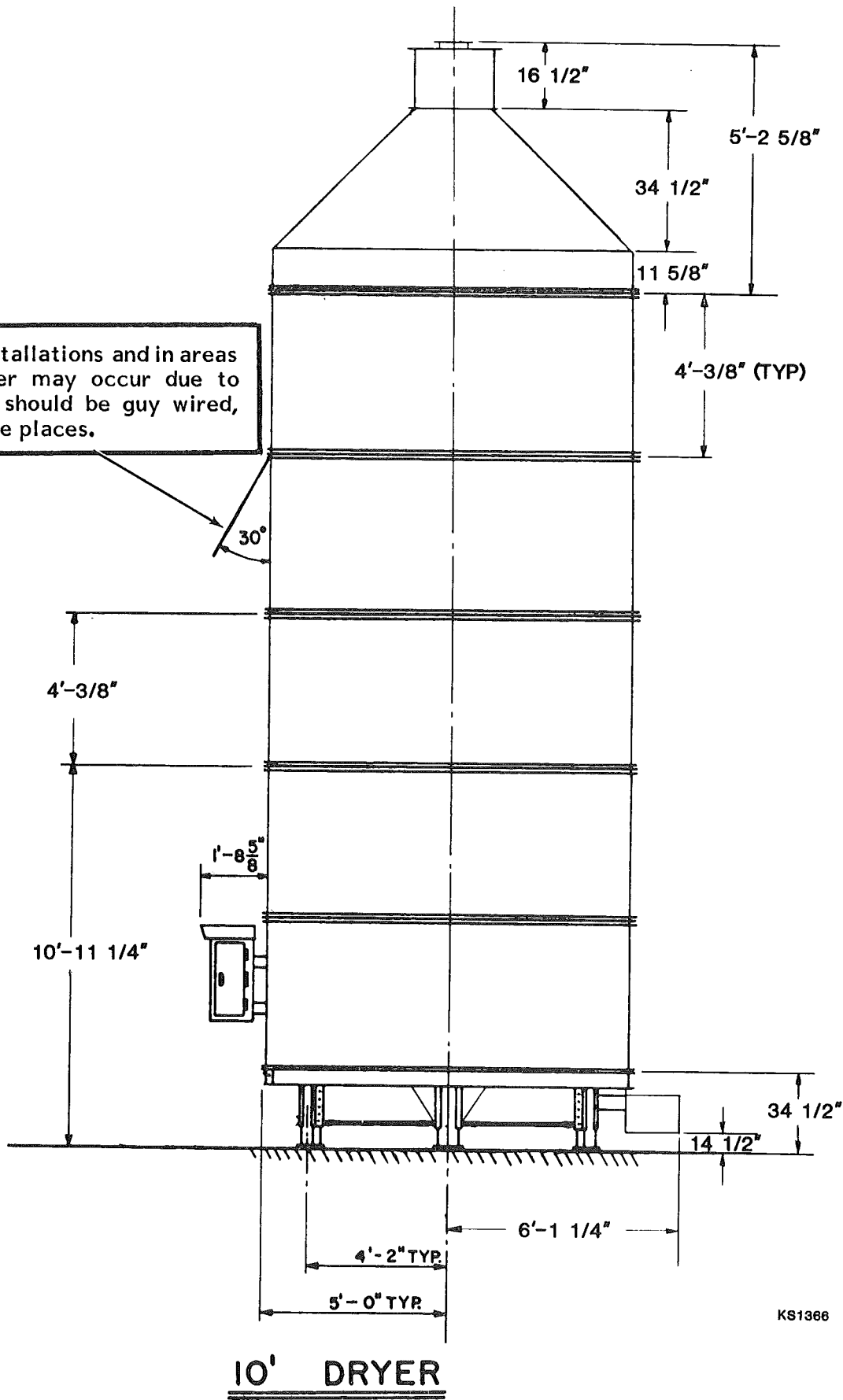

KS1366

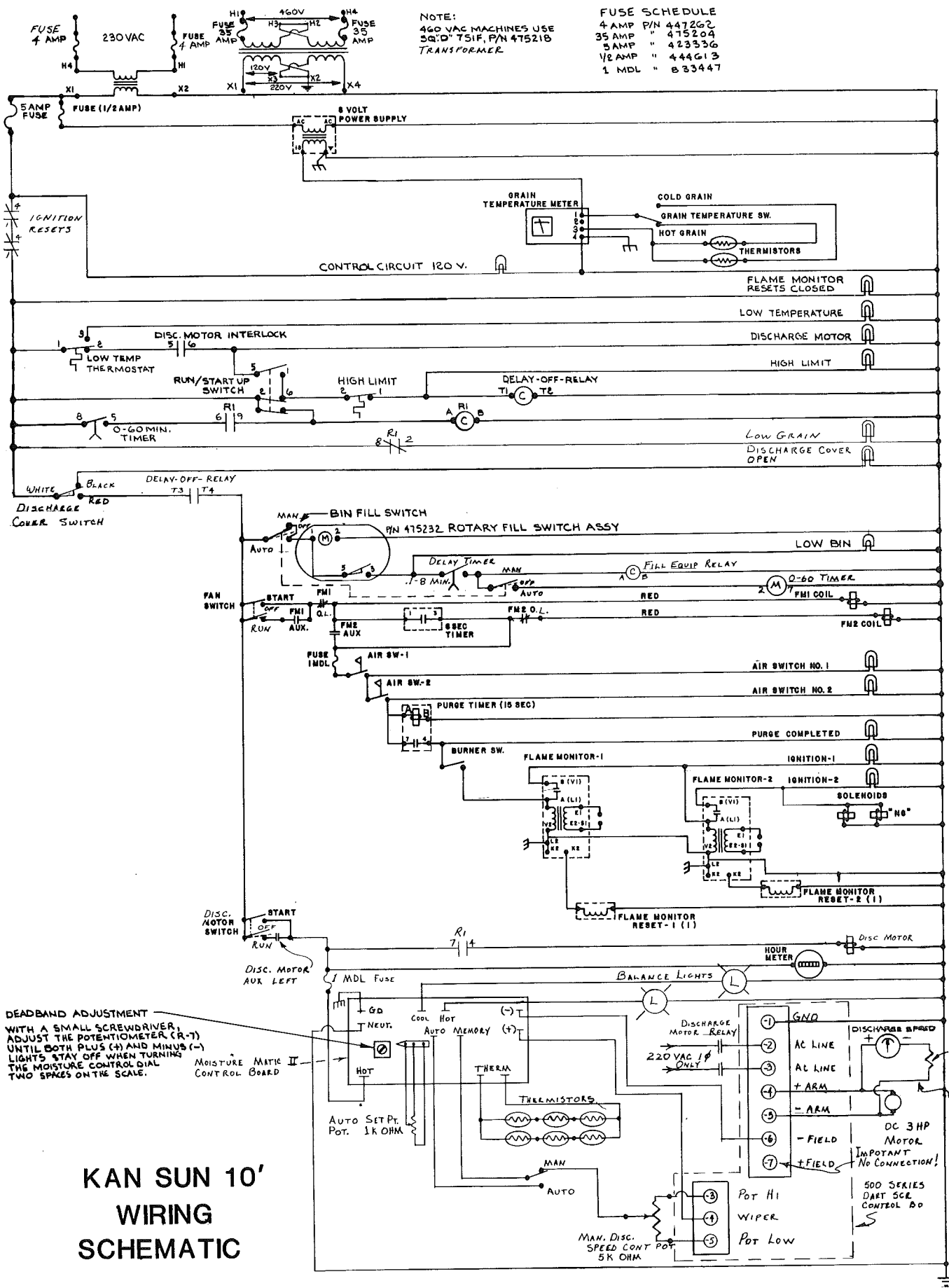

NOTE:  
 460 VAC MACHINES USE  
 30" D" TSIF, P/N 475218  
 TRANSFORMER

FUSE SCHEDULE

4 AMP	P/N 447262
35 AMP	" 475204
5 AMP	" 423336
1/2 AMP	" 444613
1 MDL	" 833447

DEADBAND ADJUSTMENT  
 WITH A SMALL SCREWDRIVER,  
 ADJUST THE POTENTIOMETER (R-7)  
 UNTIL BOTH PLUS (+) AND MINUS (-)  
 LIGHTS STAY OFF WHEN TURNING  
 THE MOISTURE CONTROL DIAL  
 TWO SPACES ON THE SCALE.

# KAN SUN 10' WIRING SCHEMATIC

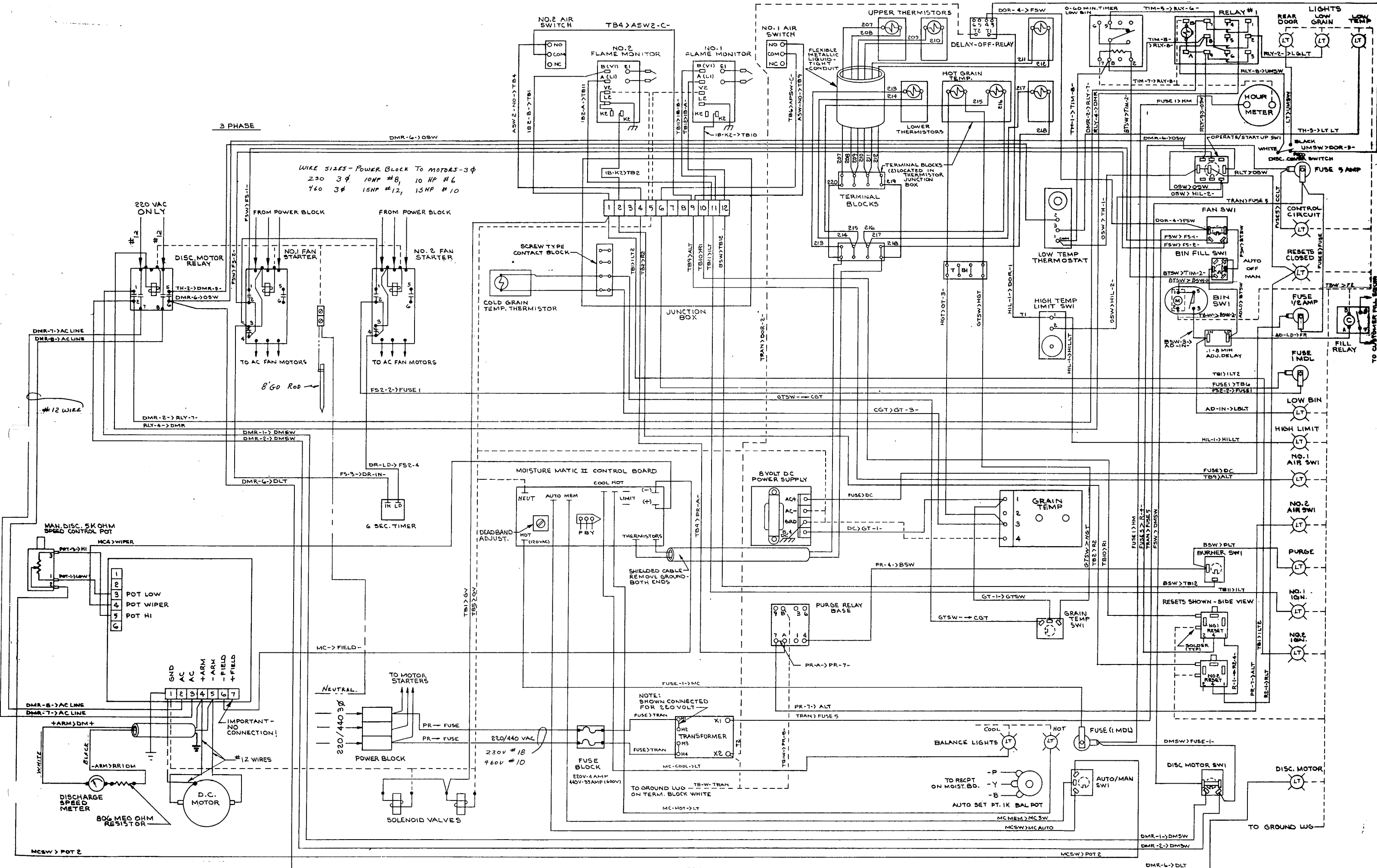

3 PHASE

WIRE SIZES - Power Block To Motors - 3φ  
 230 3φ 10HP #8, 10 HP #6  
 460 3φ 15HP #12, 15HP #10

#12 WIRE

8'60 Rod

220/440 3φ

220/440 VAC  
 230V #18  
 460V #10

NOTE: SHOWN CONNECTED FOR 220 VOLT

TO GROUND LUG - TB-W-TRAN ON TERM. BLOCK WHITE

BALANCE LIGHTS

TO RECT ON MOIST. BD.  
 -P  
 -Y  
 -B

AUTO SET PT. 1K BAL POT

DMR-4->DLT

TO GROUND LUG

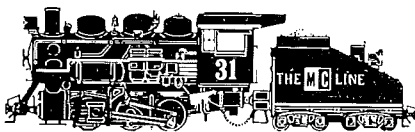
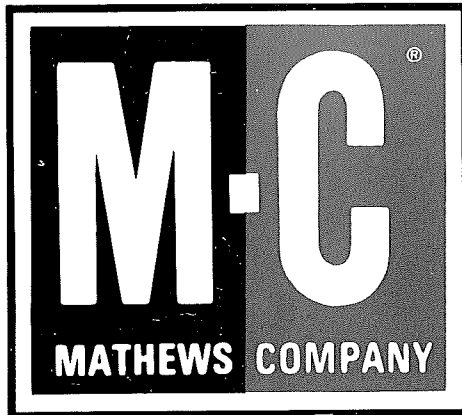

*Iron Horse Quality*