

# Installation Instructions

112 9028 REPLACEMENT KIT FOR  
OUTPUT SHAFT BEARING 001 6013  
ON MODEL 10S, 12S AND 12RS SHREDDERS

1. Bolt bearing (1) to bearing support (3).
2. Slide the bearing and support onto the output shaft.
3. Position the new bearing support on top of the old one so the output shaft is in the center of the hole in the end plate.
4. Weld the new bearing support to the old one. Loosen the bearing mounting bolts and add shims (2) as necessary to level the output shaft. Tighten the bearing mounting bolts.

112 9028 Kit consists of:

1 of 091 6001	1 3/4" PB Bearing
1 of 111 3460	Bearing Support
2 of 125 2918	Shim (16 Ga.)
3 of 001 2600	Shim (11 Ga.)
2 of 000 8140	1/2 - 13 X 2" HHCS (Grd. 5)
4 of 001 8257	1/2" SAE Flatwasher
2 of 000 8180	1/2" Lockwasher
2 of 000 8163	1/2 - 13 Locknut

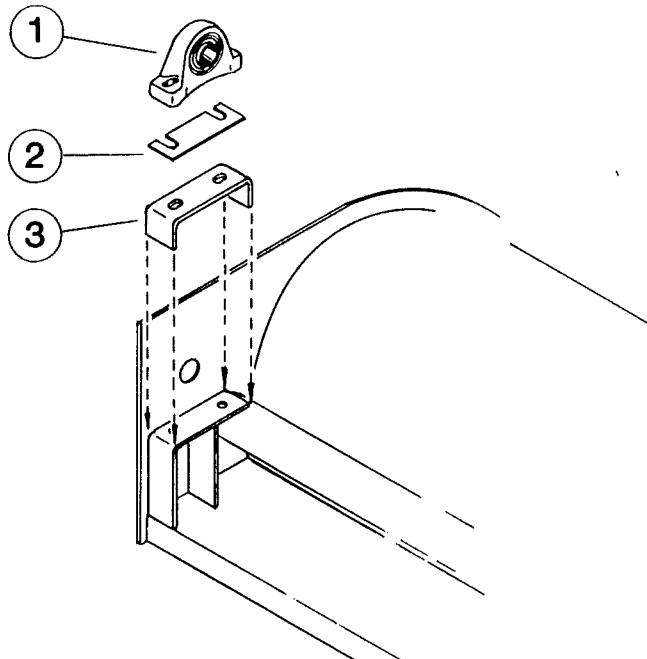

MATHEWS COMPANY  
P.O. Box 70, Crystal Lake, IL 60014