

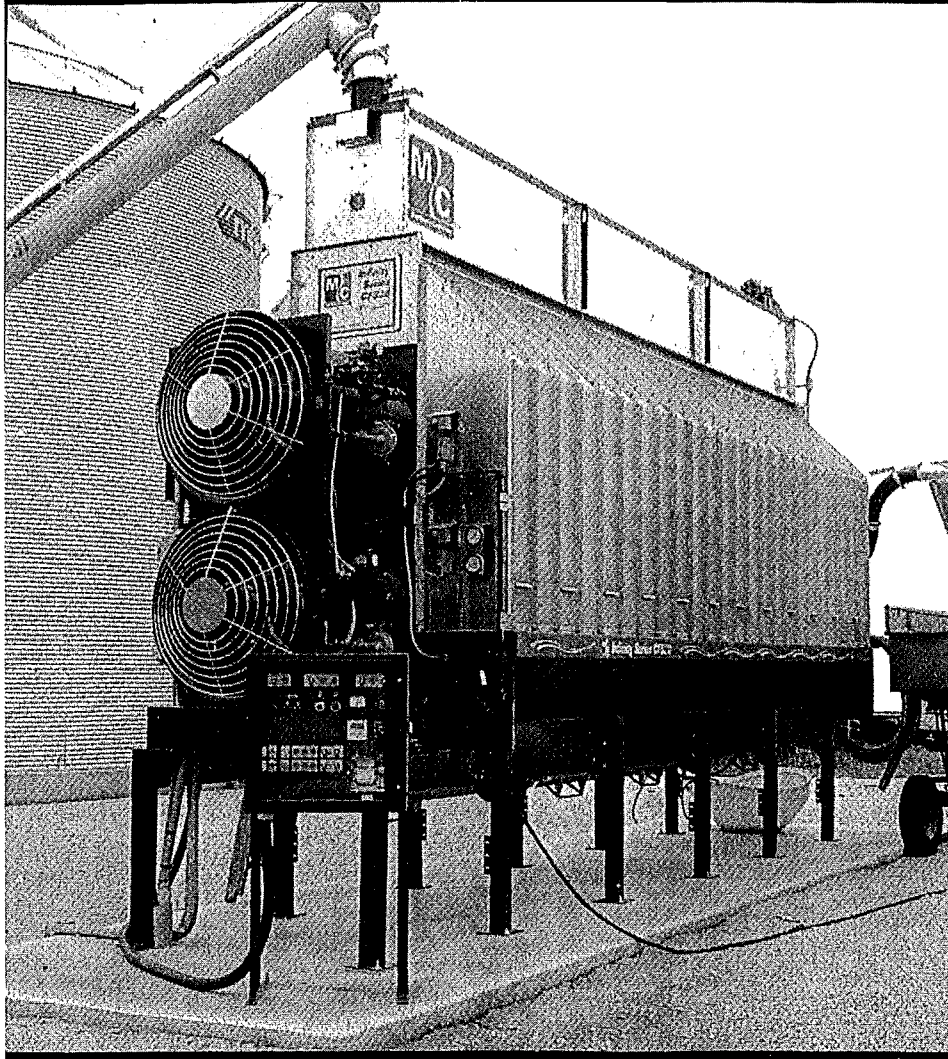

INFINITY SERIES

Models CF320, 410, 420, 520,
620, 720, 730, & 820 (EM and EMS)
Continuous Flow Grain Dryers
(Starting w/Serial No. 58393)



Model CF820 Shown w/Optional Stand Kit and Front Fill Level Auger

OPERATOR'S MANUAL

Form No. CF391 – January 2005

Mathews Company / 500 Industrial Avenue
P.O. Box 70, Crystal Lake, IL 60039-0070 USA
PHONE 815/459-2210 • FAX 815/459-5889
www.mathewscountry.com

CONTENTS

	Page
Introduction	
To the Owner-Operator	3
Safety Precautions	3
Warranty Registration	3
Model and Serial Number Location	3
Capscrew Grade Identification	4
Metric (SI) Measurement Conversion Table	4
Dimensional Drawings	
CF320 Dryer Dimension Chart & Stand (Leg) Kit Placement	53
CF410 & 420 Dryer Dimension Chart	54
CF520 Dryer Dimension Chart	55
CF620 Dryer Dimension Chart	56
CF730 Dryer Dimension Chart	57
CF720 & 820 Dimension Chart	58
Electrical & Gas Piping Entrance & Base Dimensions	52
Foundation Design for M-C Stand (Leg) Kits	
CF320	53
CF410 & 420	59
CF520, 620 & 720	60
CF730	61
CF820	62
Set-Up Instructions	
General	5
Permanent Installation	5
Portable or Temporary Installation	5
Anchoring the Dryer	5
Hopper and Level Switch Assembly Installation – CF320	5A
Hopper and Level Auger – CF410, 420, 520, 620, 720, 730 & 820	5B-6
Level Auger Motor	7
Hopper Installation	8
Level Auger Motor and Level Switch Wiring	8
Fan Clearance	9
Fill and Take Away Equipment (Customer Supplied)	9
Hopper and Level Auger (Parts & Numbers) CF410, 420 & 730	10-11
Hopper and Level Auger (Parts & Numbers) CF520, 620, 720 & 820	12-13
Electric Power Supply	14
Fan Rotation	14
Level and Discharge Auger Rotation	15
Gas Supply and Connections	15-16
Gas Consumption BTU/Hr. (Kilogram-Calories/Hr.)	16-17
Moisture Monitor Sensor Installation	18
Control Panel Lights, Switches and Controls	
CF320, 410, 420, 520, 620, 720, 730 & 820	20-22
Initial Start-Up Instructions	
General	22
Filling the Dryer	23
High Limit Switches	23
Air Pressure Switches	23
Starting the Burner(s)	24
Adjusting Vaporizer	24
Setting Burner Operating Temperature	26-27

	Page
Operating Instructions	
Level Auger Operation	28
Grain Flow Timer.....	28
Operation of the Discharge System	29
Automatic Moisture Control System.....	30
Drying Grain	31
Switching from Manual to Automatic	31
Moisture Control Setting & Adjustments When in Automatic	32
Cold Grain Shutdown Timer.....	32
End of Day Shutdown.....	32
Next Day Start-Up.....	32
Going Back to Manual.....	33
Rear Discharge Overload Door	33
Control Cabinet Heat Bulb	33
Temporary Shutdown	34
Restarts	34
Final Shutdown.....	34
Moisture Monitor & Printer	
Monitor Instructions:	
Digital Display Meter	35
Grain Temperature Button.....	35
Calibration Number Button	35
Moisture Monitor Sampling Chart.....	36
Printer Instructions:	
Weather Sensor	36-37
Printer Programming – Charts & Sample Printout.....	37-38
Printer Assembly & Troubleshooting Guide	39
Monitor Interface Board Dipswitch Settings with Printer.....	39
Maintenance	
Lubrication	40
Screens and Heat Recovery System	41
Belt Adjustment	41
Pre-Season Check	
General	41
Level Auger & Discharge Augers.....	42
Fan(s) & Burners	43-45
Direct Spark Ignition System	46
Discharge System	
Description.....	47
SCR Board Trim Pot Setting	47
SCR Board Terminal Strip Connections	47
SCR Board Trim Pot Adjusting Procedure.....	48
Troubleshooting Discharge System	49-51
Electrical Components and Part Numbers.....	63
Wiring Diagrams	
Flow Chart	64
Master Point to Point	
Moisture Monitor & Printer	
Schematic	

INTRODUCTION

To the Owner-Operator

This manual was prepared to provide owners and operators of M-C Model CF320, 410, 420, 520, 620, 720, 730, and 820 Grain Dryers (starting with serial number 58161) with Operating Instructions and Maintenance Information that will enable them to keep their M-C Grain Dryer operating at peak efficiency.

Before operating your Grain Dryer read the Start-Up and Operating Instructions. Check each item referred to and become familiar with the controls, adjustments and settings required to obtain efficient operation.

To keep the dryer operating at peak efficiency it is suggested that it be cleaned, lubricated, belt tension adjusted and the ignition system, level auger and unloading system be tested each year prior to the drying season. Refer to "Pre-Season Check" in the Maintenance section. The pre-season check can be made when the dryer is empty. Any necessary repairs or adjustments can be made so that the dryer will be ready to operate before the drying season.

Safety Precautions



This symbol is used to call your attention to instructions concerning your personal safety. Be sure to observe and follow these instructions.

A safe operator is the best insurance against accidents. The precautions listed below must be observed at all times.

- Do not allow children or bystanders to be near the Grain Dryer or grain handling machinery while it is operating.
- Do not operate the Grain Dryer without all safety shields in place and secure.

NOTE: To provide clear illustrations some of the covers, guards and shields were removed.

Warranty Registration

It is important to send in your warranty registration card as soon as your new Grain Dryer is delivered. Not only does the card validate your Grain Dryer warranty, but it is also our way of knowing who has purchased M-C equipment so that we can keep in touch with you.

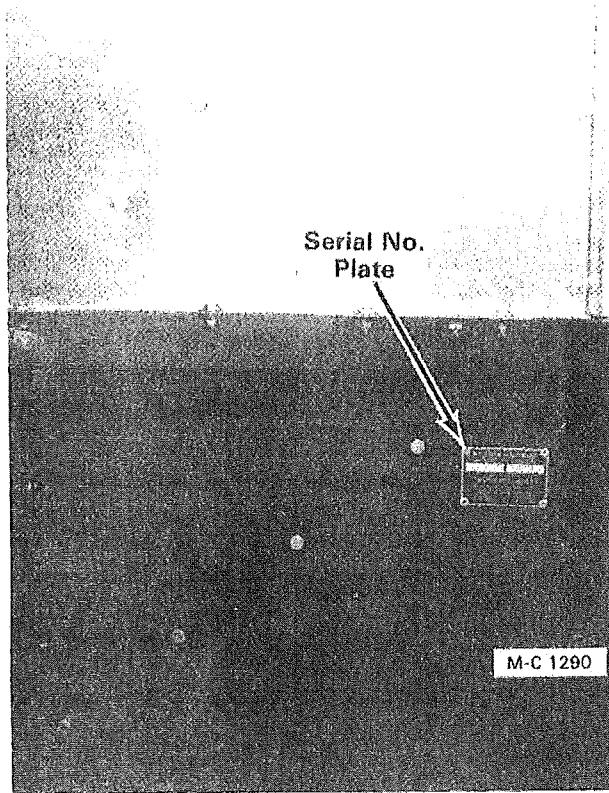

Figure A

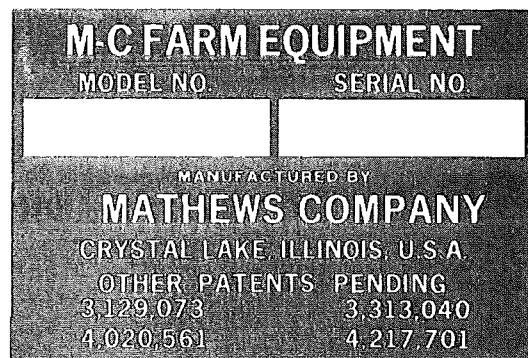

Figure B

M-C 189

Model and Serial Number Location





The model and serial number of your Grain Dryer are stamped on a plate located on the left front end panel of the base, see Figure A. For future reference, record the model and serial number in the blank spaces in Figure B.

Capscrew Grade Identification

There are four grades of hex-head capscrews. Grade 1 and 2 are common capscrews, grade 5 and grade 8 are used when greater strength is required. Each grade can be identified by the

marking on the head of the capscrew, see chart. When servicing the dryer and/or replacing capscrews, be sure to use the correct size and grade.

CAPSCREW GRADE IDENTIFICATION CHART

S.A.E. Grade	Description	Capscrew Head Marking*
1	WILL HAVE A PLAIN HEAD - NO RADIAL LINES	
2	Low or Medium Carbon Steel Not Heat Treated	
5	WILL HAVE 3 RADIAL LINES Quenched and Tempered Medium Carbon Steel	
8	WILL HAVE 6 RADIAL LINES Quenched and Tempered Special Carbon or Alloy Steel	

*The center marking identifies the capscrew manufacturer.

Metric (SI) Measurements

(English Units & Metric (SI) Equivalents)

Area

1 square inch = 6.4516 square centimeters
 1 square foot = 0.0929 square meters
 1 square yard = 0.8361 square meters
 1 acre = 4047 square meters
 1 acre = 0.4047 hectare

Force

1 pound (force) = 4.45 newtons

Length

1 inch = 25.4 millimeters
 1 inch = 2.54 centimeters
 1 foot = 304.8 millimeters
 1 foot = 30.5 centimeters
 1 foot = 0.305 meters
 1 yard = 0.9144 meters
 1 mile = 1.6093 kilometers

Mass

1 ounce = 28.35 grams
 1 pound = 0.454 kilograms
 1 ton = 907.1848 kilograms

Power

1 horsepower = 0.7457 kilowatts

Pressure

1 psi = 6.89 kilopascals
 1 psi = 0.00689 megapascals
 1 inch of mercury = 3.377 kilopascals

Temperature

1 degree Fahrenheit ($^{\circ}\text{F} - 32$) \div 1.8 = $^{\circ}\text{Celsius}$

Torque

1 inch pound = 0.113 newton meters
 1 foot pound = 1.356 newton meters

Velocity

1 mile per hour = 1.61 kilometers per hour

Volume

1 bushel = 35.24 liters
 1 bushel = 0.0352 cubic meters
 1 pint = 0.4731 liters
 1 quart = 0.9464 liters
 1 gallon = 3.7854 liters
 1 cubic inch = 16.387 cubic centimeters
 1 cubic foot = 0.0283 cubic meters
 1 cubic yard = 0.7646 cubic meters

NOTE: The Mathews Company reserves the right to incorporate any changes in design without obligation to make these changes on units previously sold.

SET-UP INSTRUCTIONS

General

Check to make sure that all the parts and hardware listed on the packing list have been received. Make claims for any shortages immediately.

The fan end of the dryer is the FRONT. LEFT and RIGHT is determined by standing at the rear of the dryer looking at the rear doors. LEFT and RIGHT of the control cabinet is determined by looking from the inside out through the control cabinet doors.

IMPORTANT: When setting up the dryer avoid dropping nuts, bolts or parts down the grain columns. If anything is accidentally dropped, it must be removed before filling the dryer with grain.

Permanent Installation

The dryer must be installed on a level concrete foundation designed to carry the weight of the dryer when full of grain. The foundation must be engineered locally for ground and weather conditions to prevent settling and frost upheaval.

Don't forget to place a support under the front of each fan housing mount channel.

IMPORTANT: The dryer must be a minimum of 13" (33cm) above the ground to provide clearance to open the quick clean unload auger pans. If the dryer is set on concrete piers perpendicular to the dryer skids, they must be notched to provide the minimum 13" (33cm) clearance. Refer to the dryer base dimension drawing at the back of this manual.

Dryer dimension drawings and an electrical and gas piping entrance drawing are at the back of this manual.

A vibration damper (treated wood planks, flat belting, etc.) should be used between the skids and the top of the piers. Be sure to anchor the dryer base to the foundation.

Lift the dryer onto the piers with four slings – two on each side. Attach the slings to or around the skids just behind the fan housings and approximately one-third in from the rear of the dryer. Use spreader bars across the top to avoid damage when lifting.

NOTE: The top of each pier must be level. If they are not, shim between the top of the pier and the vibration damper.

When unloading a dryer to be equipped with an M-C Stand Kit, try to bolt stands (legs) to the dryer base while it is being unloaded from delivering trailer with a crane or forklift.

Dryer Weight -- Approximate in pounds (kgs)

NOTE: Weights include hopper and level auger.

MODEL	EMPTY	FILLED w/No. 2 Corn (Maize)
CF320	5,000 (2,268)	16,800 (7,620)
CF520	6,250 (2,835)	27,250 (12,360)
CF410 & CF420	5,600 (2,540)	21,336 (9,676)
CF620	6,150 (2,790)	27,150 (12,315)
CF720	6,600 (2,994)	27,600 (12,519)
CF730	7,900 (3,583)	34,220 (15,519)
CF820	9,200 (4,173)	40,672 (18,449)

Portable or Temporary Installation

Place timbers or railroad ties under the skids (parallel). The dryer must be a minimum of 13" (33cm) above the ground to provide clearance to open the quick clean unload auger pans.

Don't forget to place a support under the front of each fan housing mount channel.

A dryer dimension drawing and an electrical and gas piping entrance drawing are at the back of this manual.

Anchoring the Dryer

Immediately after installation, anchor the base of the dryer to the foundation. The dryer should also be guy wired in locations where the possibility of "blow-over" from wind exists.

All anchoring material and cable are to be supplied and installed by the customer.

320 HOPPER AND HOPPER EXTENSION

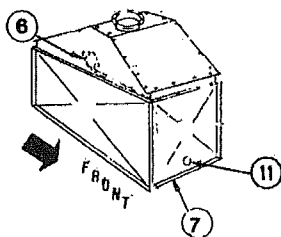

Ref.	Part No.	Qty.	Description
1	129 3412	4	Lifting Bar
2	129 2843	2	Hopper Side
3	129 2853	1	Rear Hopper End Panel w/View Lens Hole
4	124 4777	1	Hopper Extension LH
5	129 2849	1	Hopper Extension-Level Switch
6	129 1051	1	Level Switch w/Mount Plate #475231 - Rotary Type - After 1 Jan. 2005
7	129 4953	1	Front Hopper End Panel w/View Lens Hole
8	124 4776	2	Hopper Extension End Angle
9	124 4775	2	Hopper Extension Top
10	128 0336	1	Grain Receiving Inlet
11	129 5702	2	Port View Lens
	000 8212	8	¼-20 x ½" (6.35 x 12.7mm) Truss Head Bolt
	000 8167	8	¼" (6.35mm) Whiz Locknut

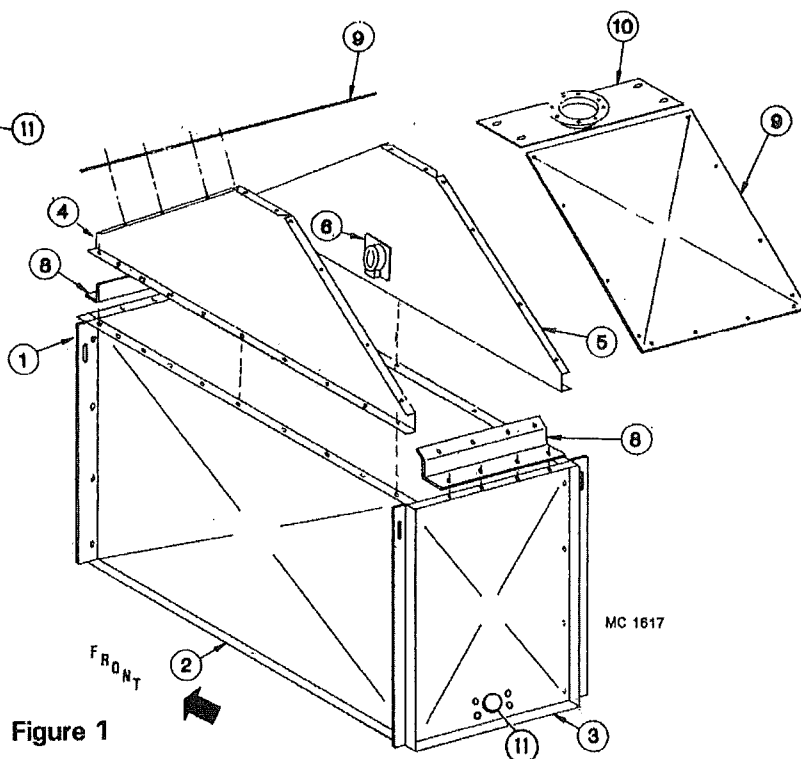

Figure 1

Assembly of 320EM Wet Grain Hopper and Level Switch (See Figure 1)

NOTE: The Hopper can be assembled on the dryer screen section or on the ground and then lifted onto the dryer screen section. If hopper is assembled on the dryer screen section, be sure to place a 28" (71cm) Stiffener Strap #1292947 across the center of the screen section top connecting both mount angles that are bolted to the top of the outer screens. See Figure 5.

IMPORTANT: The Model 320EM dryer does not have a level auger. Customer's filling equipment will function in place of level auger when wired into dryer Level Switch.

If Hopper is to be assembled on the ground, proceed as follows:

1. Bolt the Hopper Sides and End Panels together with ⅜-16 x ¾" (9.5 x 19mm) capscrews and flanged whiz locknuts (#0018210 and 0008168). Be sure to place (1) #1293412 Lifting Bar at each end of the Hopper Sides so that there will be (1) bar at each corner of the Hopper. See Figure 1.

2. Bolt the Hopper Extensions #1244777 LH and #1292849 RH to the Hopper Sides with ⅜-16 x ¾" (9.5 x 19mm) washer head hex bolts and whiz locknuts. See Figure 1.

3. Bolt the Hopper Extension End Angles #1244776 to the top of the front and rear hopper end panels with the same bolts and nuts used in #2.

4. Bolt the (2) Hopper Extension Top Panels #1244775 to the sloping flanges of the hopper extensions with the same bolts and nuts used in #2.

5. Place #1280336 Grain Receiving Inlet with 10" (25.4cm) angle ring onto top of hopper extensions and secure with ⅜ x 16 x ¾" (9.5 x 19mm) capscrews and flanged whiz locknuts.

Installation of 320EM Hopper (Assembled on Ground)

1. Place a 28" (71cm) Stiffener Strap #1292947 across the center of the screen section top connecting the mount angles that are bolted to the top of the outer screens. See Figure 5.

2. Attach cables to the (4) Lifting Bars bolted to the hopper sides. Use spreader bars between the cables and lift hopper assembly onto the top of the screen section. Check position of the Stiffener Strap so it lines up with holes in hopper sides and hopper mount angles. Hopper Assembly weighs about 180 lbs. (82 kgs).
3. Bolt Hopper Assembly to Hopper Mount Angles with $\frac{3}{8}$ -16 x $\frac{3}{4}$ " (9.5 x 19mm) hex washer head bolts and flanged whiz nuts.

dryer screen section, unwind the $\frac{3}{8}$ (9.5mm) gray liquatite conduit that has the Level Switch Mount Plate #475231 and the Level Switch Housing attached. There is a hole in the lower center of the right hopper extension panel #1292849 for the Rotary Level Switch Paddle. Insert Paddle, and bolt switch mount plate to panel with $\frac{1}{4}$ x $\frac{1}{2}$ " (6.39 x 12.7mm) truss head bolts and whiz nuts. The level switch housing will be on the outside of the wet hopper and the $\frac{3}{8}$ " (9.5mm) liquatite for the (2) Red level auger switch wires TB24-LSW-C and LSW-NC-LASW and the White neutral wire will also be on the outside of the hopper. This will make for easy access to the level switch if necessary.

Installation of 320EM Level Switch

Once the wet holding hopper is bolted to the

Hopper and Level Auger CF520/620/720 & 820

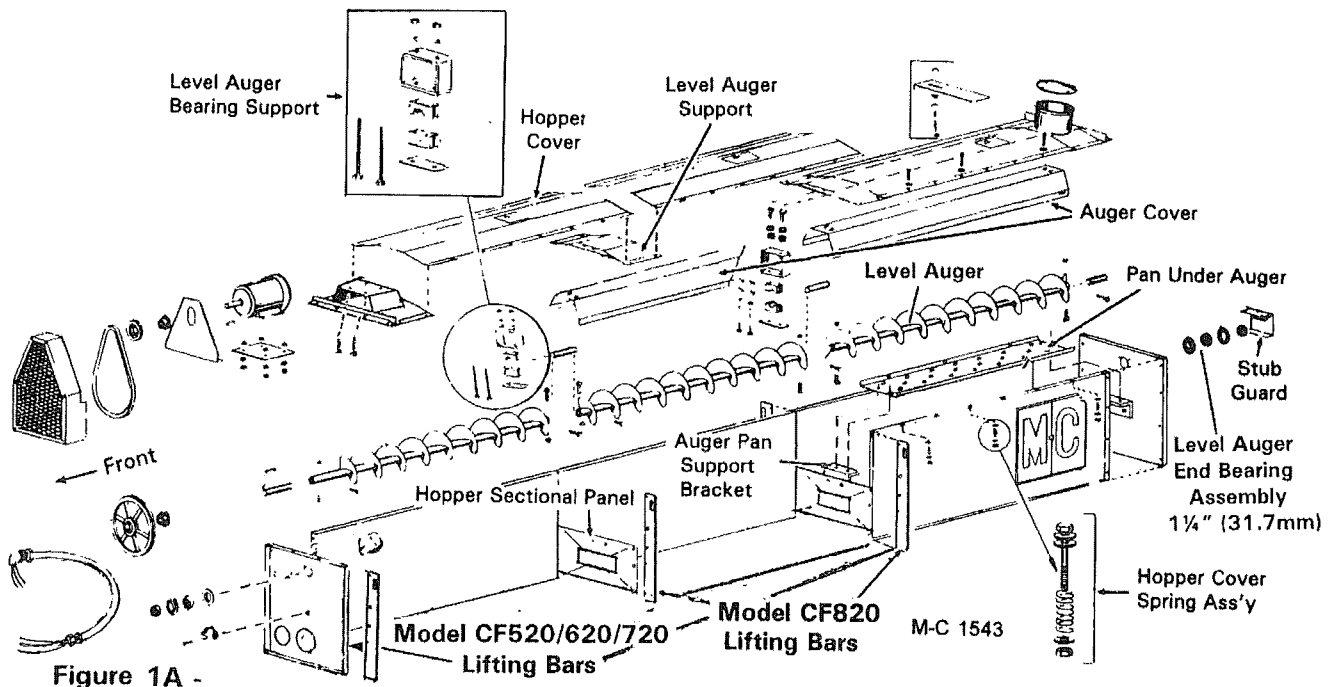

Hopper and Level Auger (See Figure 1A)

NOTE: The hopper and level auger can be assembled on the peak or on a hard flat level surface and then placed onto the top of the peak.

1. Bolt the hopper sides and end panels together with $\frac{3}{8}$ -16 x $\frac{3}{4}$ " (9.5 x 19mm) hex capscrews and flanged locknuts. Place the hopper sectional panels between the hopper side panels. Be sure to bolt (1) auger pan support bracket to the rear hopper end panel and (1) to the sectional panel. These brackets will support the slotted pan under the rear level auger section. Use $\frac{3}{8}$ " x $\frac{3}{4}$ "

(9.5 x 19mm) capscrews where bracket is bolted to end and sectional panels and $\frac{3}{8}$ " x $\frac{3}{4}$ " (9.5 x 19mm) round truss head screws where pan is bolted to support brackets (round head toward auger).

At this time also install the (4) lift bars at the (4) corners on CF410/420/520/620/720 dryers and at the front of the 2nd and 3rd hopper side panels on CF730 & CF820 dryers. Use $\frac{3}{8}$ -16 x 1" (9.5 x 25.4mm) capscrews and flanged whiz locknuts

2. Bolt level auger bearing assemblies to level auger bearing support brackets and then to the level auger support(s). See Figure 3.

DO NOT put pressure on the wood bearings by over tightening the $\frac{3}{8}$ -16 x $\frac{3}{4}$ " (9.5 x 19mm) carriage bolts and flanged locknuts.

3. Install 1 $\frac{1}{4}$ " (31.75mm) bearing w/lock collar and flangettes in each hopper end panel. Secure with $\frac{3}{8}$ -16 x $\frac{3}{4}$ " (9.5 x 19mm) carriage bolts and flanged locknuts.
4. Install the level auger front shaft 10" (25.4cm) long with keyway and a center shaft 10 $\frac{1}{4}$ " (26cm) long into the front and rear of the front auger 86" (218cm) of flighting. Bolt the front and rear shafts to the front auger with (2) $\frac{3}{8}$ -16 x 2" (9.5 x 51mm) capscrews (grade 5) and two-way locknuts.
5. Insert the auger front shaft into the bearing in the front end panel. Do not tighten the bearing lock collar.
6. Slide the level auger support assembly onto the center shaft and bolt the level auger support to the hopper sides with $\frac{3}{8}$ -16 x $\frac{3}{4}$ " (9.5 x 19mm) capscrews and flanged locknuts.
7. On Model CF730 & CF820 dryers, install a center shaft 10 $\frac{1}{4}$ " (26cm) long into the back of the center level auger 93 $\frac{1}{2}$ " (238cm) flighting and secure with (2) $\frac{3}{8}$ -16 x 2" (9.5 x 51mm) capscrews (grade 5) and two-way locknuts. Slide the front of the center auger onto the center shaft at the rear of the front level auger. Slide the other level auger support assembly onto the center shaft at

the rear of the center auger and bolt the level auger support to the hopper sides. Align the flighting and bolt the center auger to the center shaft of the front auger with (2) $\frac{3}{8}$ -16 x 2" (9.5 x 51mm) capscrews (grade 5) and two-way locknuts.

8. Slide the front of the rear auger 48" (122cm) on CF410, 420, & 730 models and 93 $\frac{1}{2}$ " (238cm) on CF520, 620, 720, & 820 models onto the center auger shaft at the back of the front auger (410, 420, 520, 620, & 720 models). On CF730 and CF820 models the rear auger will be placed onto the center shaft at the rear of the center auger. Align the flighting and bolt the rear auger to the center shaft at the rear of the front auger or rear of the center auger on CF730 and CF820 models with (2) $\frac{3}{8}$ -16 x 2" (9.5 x 51mm) capscrews (grade 5) and two-way locknuts.
9. Slide the level auger rear shaft 8" (20cm) long through the bearing in the rear end panel into the rear auger. Do not tighten the bearing lock collar. Bolt the rear shaft to the rear level auger with two $\frac{3}{8}$ -16 x 2" (9.5 x 51mm) capscrews (grade 5) and two-way locknuts.
10. Rotate the level auger by hand and check alignment. Tighten both bearing lock collars and set screws.
11. Bolt the receiving hopper and level auger motor mount to the top of the hopper with $\frac{3}{8}$ -16 x $\frac{3}{4}$ " (9.5 x 19mm) capscrews, flat-washers and flanged locknuts. Bolt the stub guard to the top of the hopper rear end panel.

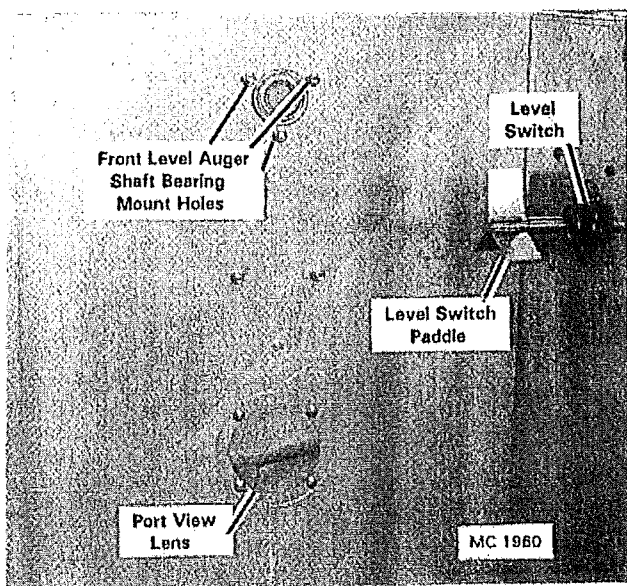

**Figure 2 - Level Switch
(Inside Hopper View - 410-820)**

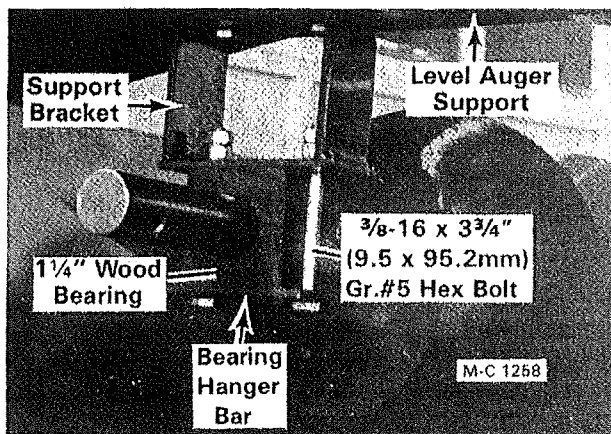

Figure 3 - Level Auger Bearing

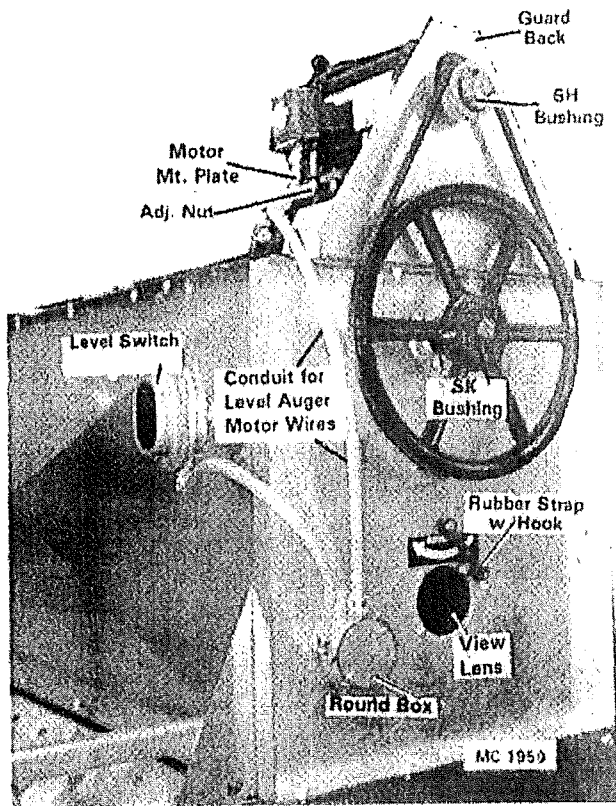

Figure 4 - Level Auger Drive

12. Install the hopper covers. The front cover on all models is 76" (193cm) long. The rear hopper cover on models 520, 620, 720, & 820 is also 76" (193cm) long. The rear hopper cover on models CF410, 420, & 730 is only 34½" (88cm) long. The center hopper cover on models CF730 and CF820 is 83" (211cm) long. Secure each cover to the left side of the hopper side panel with (4) ¼-2 x 2" (7.35 x 51mm) capscrews, flatwashers, springs and two-way locknuts as shown in Figure 1A.

Level Auger Motor

1. Bolt the level auger motor to the motor mount plate. Use ¾-16 x 1¼" capscrews and flanged locknuts on 3HP single phase motors and 5/16-18 x ¾" (7.9 x 19mm) capscrews and flanged locknuts on 3HP (CF410, 420, 520, 620, 720, & 730) and 5HP (CF820) three phase motors.
2. Put four ½-13 x 3½" (12.7 x 89mm) full thread capscrews in the level auger motor mount and lock in place with flanged locknuts. Thread a ½-13 (12.7mm) hex nut onto each capscrew and install the motor mount plate with motor, see Figure 4.

3. Install the level auger guard back as shown in Figure 4. Install a ¼" x ¼" x 2" (6.35 x 6.35 x 51mm) key in the level auger shaft and a ¼" x ¼" x 1¾" (6.35 x 6.35 x 44.5mm) key in the 3HP motor shaft or 5HP motor shaft.
4. The level auger pulley and motor pulley are held on the shafts with tapered bushings. Before installing the pulleys and bushings thoroughly inspect the tapered bore of the pulleys and the tapered surface of the bushings. Any paint, dirt, oil or grease **must** be removed.
5. Place the SK bushing 1¼" (31.75mm) bore into the level auger pulley and the SH bushing 1½" (28.6mm) bore into the motor pulley. The bushing and the bore of the pulley are tapered. Be sure to install the bushing into the large ID of the pulley tapered bore. If the bushing is installed into the small ID of the pulley, the pulley hub will crack when the mounting capscrews are tightened.
6. Place the three capscrews through the open holes in the bushing and thread them into the pulley by hand. **DO NOT** tighten the capscrews.

IMPORTANT: The capscrew and pulley threads must be clean and dry. Do not lubricate.

7. Slide the pulley and bushings onto the shafts. If the bushings are too tight on the shaft, wedge a screwdriver blade into the saw cut in the flanged (not the tapered surface) to spread the bushing.
8. Install the belt and adjust the position of the pulleys to align the belt.
9. Tighten the three capscrews in the bushings evenly and progressively. Torque motor bushing capscrews to 9 ft. lbs. (1.25kgm) and level auger pulley bushing capscrews to 15 ft. lbs. (2.07 kgm).

IMPORTANT: The tightening force on the three capscrews is multiplied many times by the wedging action of the bushing tapered surface. Do not exceed the specified torque or use a lubricant on the capscrew threads. To do so may create bursting pressures in the hub of the pulley.

NOTE: There should be 1/8 to 1/4" gap (3.2 to 6.4mm) between the pulley hub and the flange of the bushing. If the gap is closed, the shaft is undersize.

10. Adjust the belt tension by loosening the locknuts and raising the motor mount plate evenly with the four adjusting nuts, then tighten the locknuts.
11. Install the rubber strap with hook to the front end panel as shown in Figure 4. Hook the level auger guard over the top of the guard back and secure with the rubber strap and hook.
12. Remove the level auger motor junction box cover and the round junction box cover. Connect the flexible conduit and wire assembly 36" long (91.5cm) to the motor and round box. See Figure 4.

NOTE: All wiring to be completed by a qualified electrician.

13. **Three phase motor** - Connect the wires in the level auger motor junction box to the terminals on the motor as follows:

Connect the red wire to terminal T1, blue wire to terminal T2 and the black wire to terminal T3. Connect the green wire to the motor grounding screw.

14. **Single phase motor** - Refer to the wiring information on the inside of the level auger motor junction box cover. The level auger pulley **MUST** turn clockwise (viewed from the front of the dryer). Determine correct motor rotation and connect the red and black wires to the motor terminals specified on the diagram in the junction box cover. Connect green wire to the motor grounding screw.

Hopper Installation

1. Place a stiffener strap #1292947 28" (71cm) long across the center of each set of hopper mount angles bolted to the top of the outer screens. A CF410 & 420 require (1) strap, CF520, 620, 720 & 730 require (2) straps, and a CF820 requires (3). See Figure 5.
2. Attach cables to the lift bars on the hopper. Use spreader bars between the cables and lift the hopper onto the top of the peak assembly, see Figure 1.
3. Bolt the hopper to the hopper mount angles with 3/8-16 x 3/4" (9.5 x 19mm) capscrews and flanged locknuts.

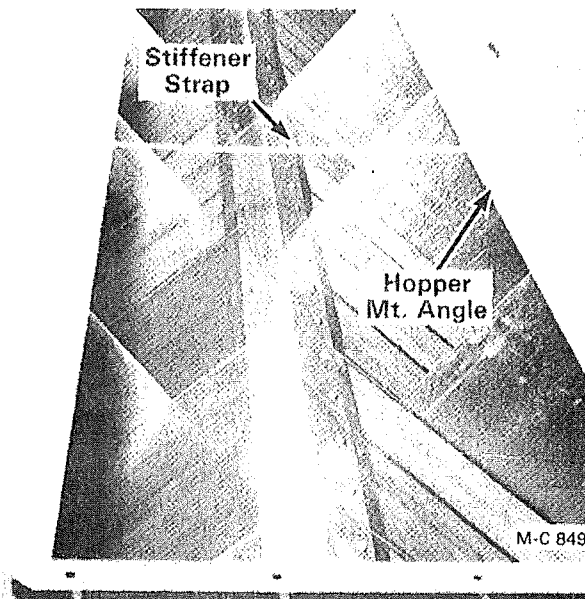

Figure 5

Level Auger & Wet Hopper Weight Approximate in pounds (kgs)	
CF410 & 420	550 (249)
CF520, 620 & 720	610 (279)
CF730	680 (308)
CF820	745 (338)

Level Auger Motor and Hopper Level Switch Wiring

NOTE: The level auger switch and motor wire assembly consists of a length of 1/2" (12.7mm) flexible conduit and wire.

1. Connect the flexible conduit to the bottom of the round junction box on the hopper front end panel. See Figure 4.
2. Connect the wires in the round junction box together with wire nuts furnished (tape all connections).
 - A. Connect the (2) red wires imprinted TB24-B → LSW-C together, the (2) red wires imprinted LSW-NC- → LASW together, and the (2) white neutral wires.
 - B. Connect the (2) black wires together, (2) red wires together and (2) blue wires together (blue used on three phase dryers only). There are (2) green motor ground wires that also must be connected.

Fan Clearance

NOTE: Remove the tie down wire from each fan. These wires keep the fans from rotating during shipment.

1. Before turning on the electric power, check for clearance between fan and fan housing. The fit between fan and housing is very close. Some shifting may have occurred during shipping. Clearance can be checked by turning fan by hand.



CAUTION: Do not touch any part of the fan while it is in motion -- even when turned by hand.

2. To adjust fan clearance, loosen the four locknuts under the motor base and turn the adjusting nuts on top to raise or lower the motor. See Figure 6. The holes in the base are slotted to allow for side to side adjustment. Tighten locknuts after adjustment has been completed.
3. Install the fan guards.

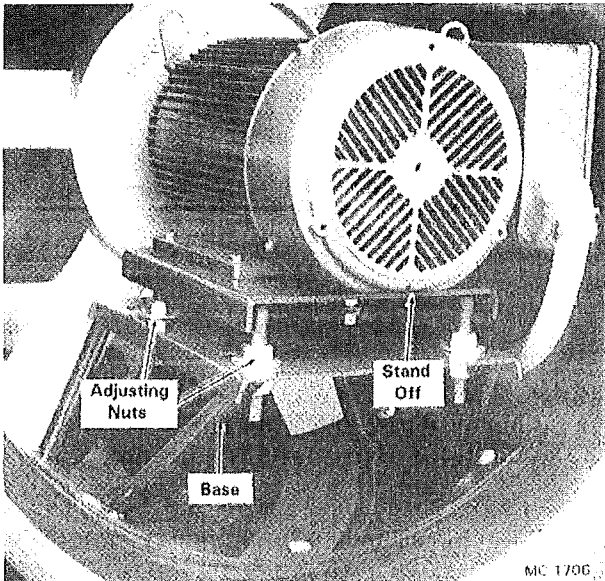

Figure 6

Filling Equipment (Customer Supplied)

1. There are two general methods used to fill the dryer - downspouting from an overhead wet bin or with an auger from the wet bin.
2. Be sure that the system used has the grain moving capacity to fill the dryer faster than the grain shrinks and dries. If it does not, the Grain Flow Timer will shut the dryer down when the grain level in the hopper is low.

3. **Gravity Filling System** — To prevent overloading the level auger, a slide gate must be installed in the downspout to regulate the flow of grain to the level auger.

Fill Auger and Take Away

Equipment (Customer Supplied)

1. The fill auger **MUST** be controlled by the dryer. The take-away equipment can be controlled by the dryer or separately.
2. On Model CF320, the power for the fill auger motor contactor is controlled by the non-powered contacts of the relay provided in the motor control cabinet. See Figure 7A.
3. On Models CF520/620/720 and CF820, which have a level auger, the non-powered auxiliary contacts of the level auger starter are used to control the fill auger motor contactor. See Figure 7B.

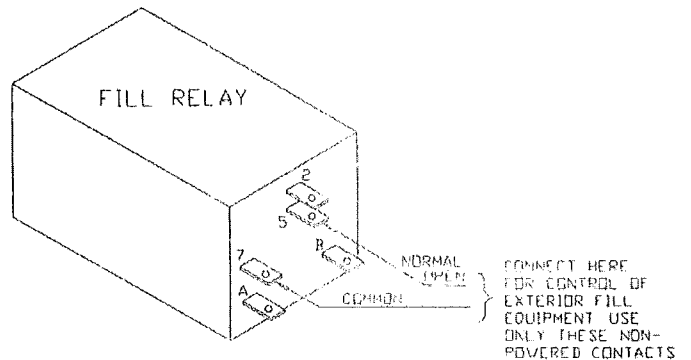

Figure 7A - 320 Relay Non Powered Contacts

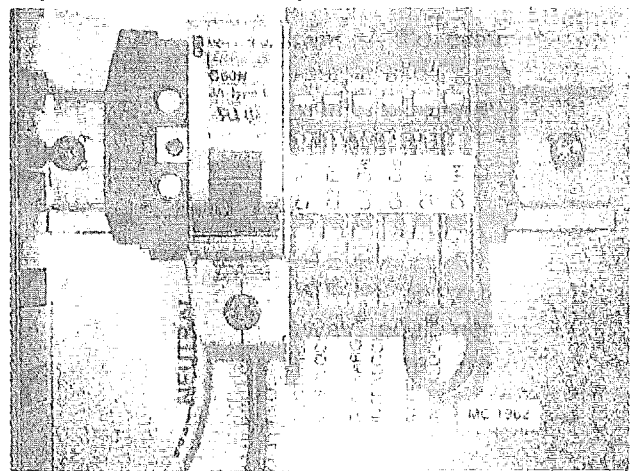

Figure 7B - 570 thru 970

Wire Terminals for Control of Customer Supplied Grain Fill & Take Away Equipment

- Terminals C1 & C2 to Fill
- Terminals C3 & C4 to Take Away

Hopper and Level Auger

Hopper and Level Auger for Models 410, 420, & 730

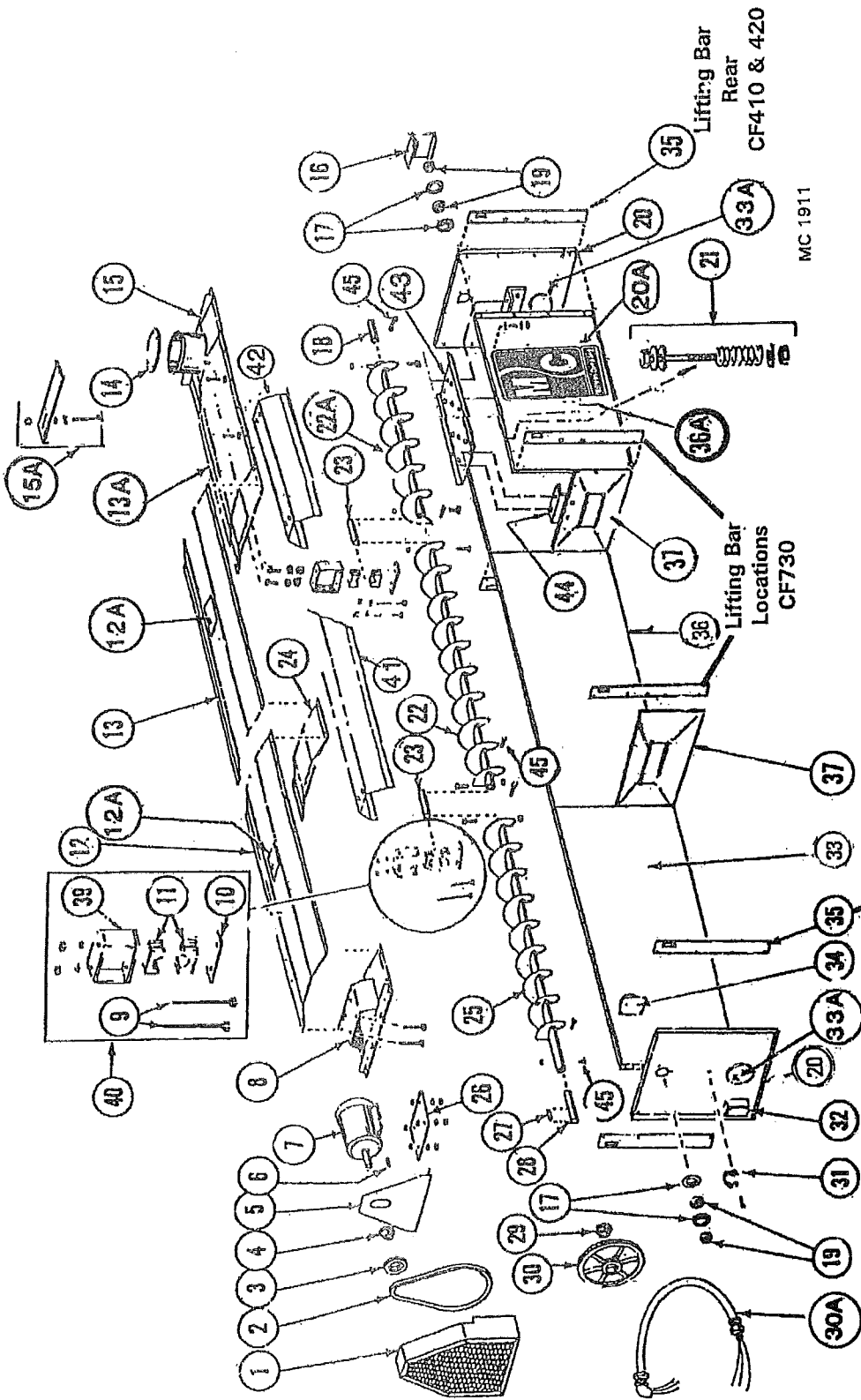

Figure 5 12 ft. 20 ft.
(3.65m) (6.0m)

Ref. Part No.	Qty.	Description	Ref. Part No.	Qty.	Description
1	1	Level Auger Guard	22A	1	Level Auger Rear 48" (122cm) RH Fighting
2	1	2/3V/710 (banned belt) or 128 6104 in. matched set of two	23	1	Level Auger Center Shaft 1 1/4" x 10 1/4" (3.175 x 26cm)
3	1	3V/3.65 x 2 Groove Pulley 60 Cycle	24	2	Level Auger Support 1 1/4" x 10 1/4" (3.175 x 26cm)
4	1	3V/4.5 X 2 Groove Pulley 50 Cycle	25	1	Level Auger Front 86" (218cm) RH Fighting
	1	1 1/2" (28 6mm) SH Bushing for 3HP motor (incl. capscrews & lockwashers)	26	1	Level Auger Motor Mount Plate
			36		Lifting Bar Locations CF730
			35		Lifting Bar Rear CF410 & 420
			33A		

Hopper and Level Auger for Models 410, 420 & 730

5	129 4944	1	1	Level Auger Guard Back	4	000 8161	4	½-13 x 3½" (12.7 x 89mm)
6	001 5119	1	1	Key - ¼" x ¼" x 2" (6.35x6.35x51mm)	4		4	Capscrew (Full Thread)
7	128 6818	1	-	3HP motors	4		4	½-13 (12.7mm) Flanged Locknut
	128 6829	1	1	3HP 30 Motor 230/380/460V	8		8	½-13 (12.7mm) Hex Nut
8	129 0001	1	1	3HP 10 Motor 230V-520/620/720/820	27		1	Key-¼" x 1½" (6.35 x 38.1mm)
9	001 8287	2	4	Level Auger Motor Mount	28		1	Level Auger Front Shaft
	000 8162	4	8	¾" -16 x 3¾" (9.5 x 95.2mm)	29		1	1¼" x 10" (3.175 x 25.4cm)
	128 3415	1	2	Capscrew - Grade 5	30		1	1¼" (31.75mm) SK Bushing
	128 6021	1	2	¾-16 Hex Nut	30A		1	Incl. capscrews & lockwashers
	129 2945	1	1	Bearing.Hanger Bar	31		1	3V/19.0 x 2 Groove Pulley
12A	128 8355	2	3	Wood.Bearing - 1¼" (31.75mm)	32		1	L.A. Motor Flexible Conduit w/Wires
13	129 2946	-	1	2 halves	33		1	Rubber Strap w/Hook
13A	125 2946	1	1	Hopper Cover Front 76" (193cm)	33A		2	Round Box ½" (12.7mm)
14	129 4204	1	1	Warning Decal	34		1	Hopper Side Panel - Front RH
15	129 0002	1	1	Hopper Cover - Center 83" (211cm)	35		4	Port View Lens
15A	129 4205	1	1	Hopper Cover Rear 28" (71cm)	36		3	Level Switch - Rotary
	129 5703	1	1	Receiving Tube Cover	36A		2	After 1 Jan. 2005, see page 37
	000 8168	3	3	Receiving Hopper	37		2	Lifting Bar
16	129 4947	1	1	Flow Restrictor	38		8	Hopper Side Panel
	001 6004	4	4	Position & Locking Bolt	39		2	Hopper Side Rear
18	128 5052	1	1	¾-16 Flanged Locknut	001 8209		2	Hopper Sectional Panel
	001 6003	2	2	Stub Guard	001 8139		4	Hopper Brace
	129 2848	2	2	Bearing Flangette 1¼" (31.75mm)	000 8162		4	Level Auger Brg. Support Bracket
20	129 2848	2	2	Level Auger Rear Shaft 1¼" x 8" (31.75 x 203mm)	122 1008		1	¾-16 x 1" (9.5 x 25.4mm)
20A	124 8307	2	2	Level Auger Rear Shaft 1¼" x 8" (31.75 x 203mm)	001 8139		4	Hex Washer Head Bolt - Grade 5
21	000 8101	10	16	Bearing w/Lock Collar 1¼" (31.75mm)	000 8162		4	Hex Nut (9.5mm)
	131 8718	10	16	Hopper End Panel - Both w/View Lens	129 2839		1	Level Auger Bearing Kit (Incl. Ref. 9, 10, 11 & 39 in quantities reqd. for (1) bearing)
	000 8172	30	48	M-C Decal 23" x 23" (58.4x58.4cm)	125 2947		1	Auger Cover Long
	000 8210	10	16	¾-20x2" (6.35x51mm) Capscrew	125 2761		1	Auger Cover Short
22	128 0122	-	1	Spring ⅝" OD x 1 ⅜" (15.9 x 44.5mm) Plated	128 2760		2	Pan Under Auger
				¼" (6.35mm) Flatwasher	001 8137		8	Auger Pan Support Bracket
				¾-20 Two-Way Locknut	001 8149		8	¾"-16 x 2" (9.5x50mm) Capscrew-Gr.5
				Level Auger Center 93½" (238cm) RH Flighting				¾"-16 (9.5mm) Two-Way Locknut

Hopper and Level Auger for Models 520, 620, 720, & 820

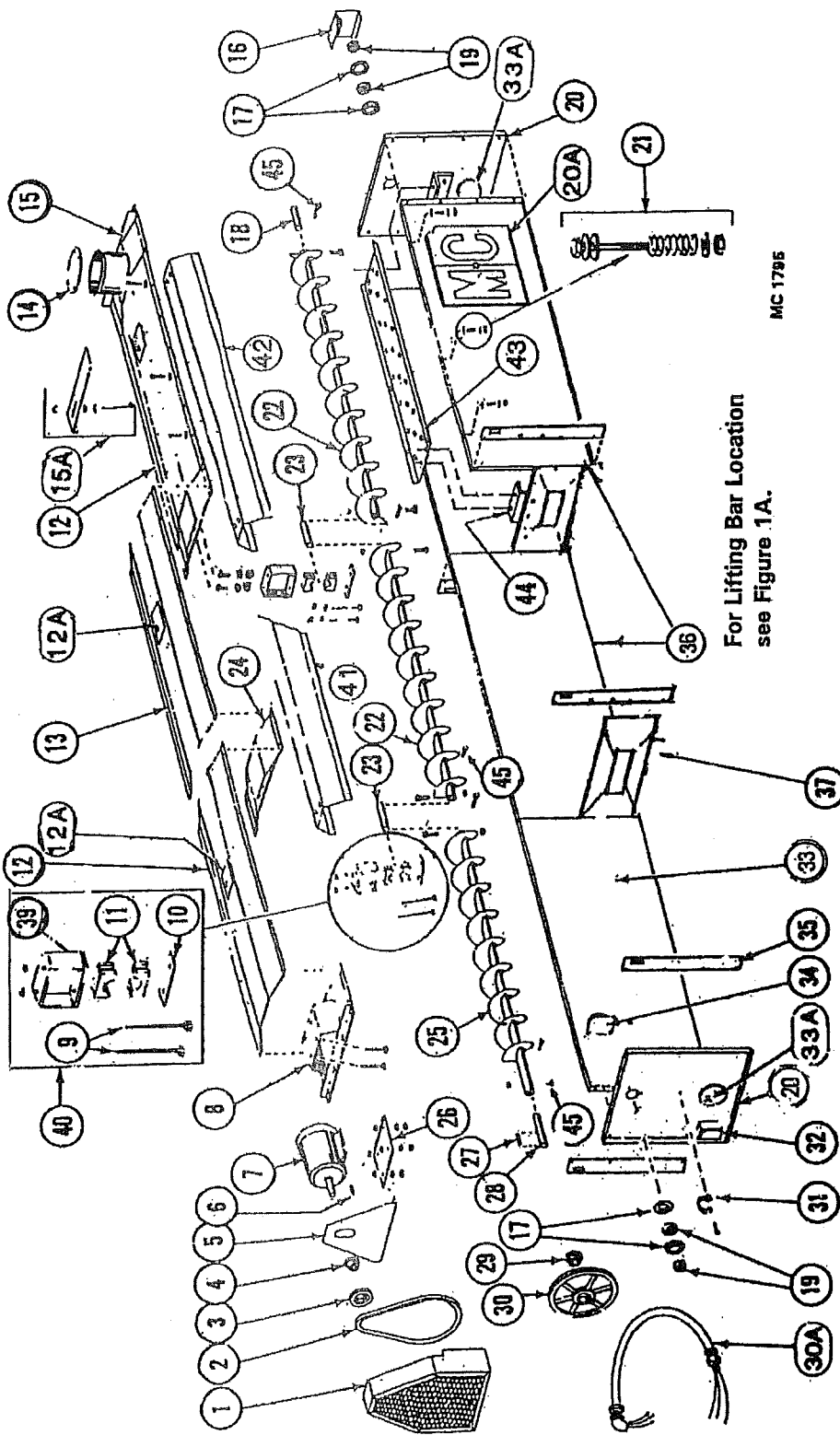

Figure 5

16 ft. 24 ft.
(4.9m) (7.3m)

16 ft. 24 ft.
(4.9m) (7.3m)

Ref. Part No.	Qty.	Description	Ref. Part No.	Qty.	Description
1	1	Level Auger Guard	22	1	Level Auger 93 1/2" (238cm) RH Fighting
2	1	2/3V/710 (banded belt) or 128 6104 in matched set of two	23	1	Level Auger Center Shaft 1 1/4" x 10 1/4" (3.175 x 26cm)
3	1	3V/3.65 x 2 Groove Pulley 60 Cycle	24	1	Level Auger Support
4	1	3V/4.5 X 2 Groove Pulley 50 Cycle	25	1	Level Auger 86" (218cm) RH Fighting
	1	1 1/2" (28.6mm) SH Bushing for 3HP & 5HP motor (incl. capscrews & lockwashers)	26	1	Level Auger Motor Mount Plate

Hopper and Level Auger for Models 520, 620, 720, & 820

5	129 4944	1	1	Level Auger Guard Back	000 8161	4	4	1/2-13 x 3 1/2" (12.7 x 89mm)
6	001 5119	1	1	Key - 1/4" x 1/4" x 2" (6.35x6.35x51mm) 3HP & 5HP motors	000 8170	4	4	Capscrew (Full Thread)
7	128 6818	1	-	3HP Motor 230/380/460V	000 8163	8	8	1/2-13 (12.7mm) Flanged Locknut
	128 6815	-	1	5HP Motor 230/380/460V	001 5120	1	1	Key-1/4" x 1 1/2" (6.35 x 38.1mm)
	128 6829	1	1	3HP 10 Motor 230V-520/620/720/820	128 5051	1	1	Level Auger Front Shaft
8	129 0001	1	1	Level Auger Motor Mount	121 6241	1	1	1 1/4" x 10" (3.175 x 25.4cm)
9	001 8287	2	4	3/8"-16 x 3 3/4" (9.5 x 95.2mm) Capscrew - Grade 5	128 6208	1	1	1 1/4" (31.75mm) SK Bushing
	000 8162	4	8	3/16 Hex Nut	128 1960	1	1	Incl. capscrews & lockwashers
10	128 3415	1	2	Bearing Hanger Bar	128 8951	1	1	3V/19.0 x 2 Groove Pulley
11	128 6021	1	2	Wood Bearing - 1 1/4" (31.75mm) 2 halves	123 6884	1	1	L.A. Motor Flexible Conduit w/Wires
12	129 2945	2	2	Hopper Cover - Front & Rear 76" (193cm)	129 2857	1	1	Rubber Strap w/Hook
12A	128 8355	2	3	Warning Decal	129 5702	2	2	Round Box 1/2" (12.7mm)
13	129 2946	-	1	Hopper Cover - Center 83" (211cm)	129 1051	1	1	Hopper Side Panel - Front LH (L.A. Switch)
	129 4204	1	1	Receiving Tube Cover	129 3412	4	4	Port View Lens
15	129 0002	1	1	Receiving Hopper	129 2836	3	5	Level Switch - Rotary After 1 Jan. 2005, see page 37
15A	129 4205	1	1	Flow Restrictor	129 2715	1	2	Lifting Bar
	129 5703	1	1	Position & Locking Bolt	128 0292	1	2	Hopper Side Panel
16	000 8168	3	3	3/8-16 Flanged Locknut	001 8209	2	4	Hopper Sectional Panel
	129 4947	1	1	Stub Guard	001 8139	2	4	Level Auger Brg. Support Bracket
17	001 6004	4	4	Bearing Flangette 1 1/4" (31.75mm)	000 8162	2	4	3/8-16 x 1" (9.5 x 25.4mm)
18	128 5052	1	1	Level Auger Rear Shaft 1 1/4" x 8" (31.75 x 203mm)	122 1008	1	2	Hex Washer Head Bolt - Grade 5
19	001 6003	2	2	Bearing w/Lock Collar 1 1/4" (31.75mm)	129 2839	-	1	9/16" (9.5mm) Lockwasher
20	129 2848	2	2	Hopper End Panel - Both w/View Lens	128 2761	1	1	3/8-16 (9.5mm) Hex Nut
20A	124 8307	2	2	M-C Decal 23" x 23" (58.4x58.4cm)	128 2760	2	2	Level Auger Bearing Kit (Incl. Ref. 9, 10, 11 & 39 in quantities reqd. for one bearing)
21	000 8101	12	18	1/4-20x2" (6.35x51mm) Capscrew	001 8137	8	12	Auger Cover Long
	131 8718	12	18	Spring 3/8" OD x 1 3/4" (15.9 x 44.5mm) Plated	001 8149	8	12	Auger Cover Short
	000 8172	36	54	1/4" (6.35mm) Flatwasher	001 8137	8	12	Pan Under Auger
	000 8210	12	18	1/4-20 Two-Way Locknut	001 8137	8	12	Auger Pan Support Bracket
								3/8-16 x 2" (9.5 x 50mm) Capscrew - Grade 5

4. On Models CF520/620/720 and CF820 unload auger motor contactors have non-powered auxiliary contacts that can be used to control the customer supplied take-away equipment. See Figure 7B.

Electric Power Supply

NOTE: All wiring must be done by a qualified electrician.

1. It is the customer's responsibility to provide the power source to the control cabinet that meets all requirements of the local electrical codes. The power supply must be adequately fused and have a main disconnect.
2. Connect the power supply to the top lugs of the dryer disconnect switch located in the upper motor control cabinet. See Figure 8.
3. When a 230 volt power supply is used, connect the supply neutral wire to the isolated neutral lug located in the motor control cabinet. See Figure 8.
4. The dryer must be connected to the earth ground rod that is supplied with the dryer. Connect the ground lug in the dryer motor control cabinet to the ground rod with at least a #6 solid copper wire or in accordance with local code.

IMPORTANT: The dryer controls operate on 50/60 cycle single phase 110/115V power. Dryers that operate on 230V three phase power

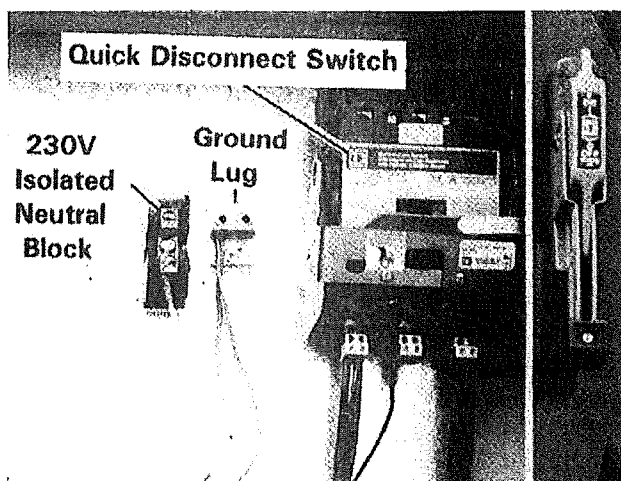

Figure 8 - Motor Control Cabinet
Model CF720 Single Phase 230 Volt

must have the 230V supply wire connected to the center lug of the dryer disconnect switch as shown in Figure 8. If the 230V power supply wire is mistakenly connected to a 115V lug and the 115V wire that supplies power to the dryer controls is connected to this lug, the dryer controls will be damaged.

5. For this reason, the 115V power supply wire to the dryer control panel is not connected to the disconnect switch at the factory. There is a loose black wire with an orange tag attached that reads "115 Volts" that is close to the disconnect switch. Connect this wire to one of the 115 volt lugs at the bottom of the switch. See Figure 8.

Dryers operating on 208, 460 and 575 volt power have a step-down transformer installed and wired to provide the 115 volt electricity required for the dryer controls.

Fan Rotation

IMPORTANT: Before checking fan rotation, inspect for and remove any foreign material (nuts, bolts, tools, parts, etc.) from the hopper, grain columns, metering rolls, unload auger and heat chambers.

1. Check fan rotation from the front of the dryer. Fan must turn counterclockwise.



CAUTION: Do not turn the electric power on until the fan guard has been installed.

2. Turn all switches on the control panel to the OFF position. Turn on the electric power supply to the dryer by pushing the dryer disconnect lever up to the ON position.
3. Turn the 115V Power Switch to the ON position and the Indicator Lamp will light. The High Limit Indicator Lamp will also light. If the High Limit Lamp does not light push the reset button on the High Limit Switch.
4. With everyone clear of the fan, push the fan start button. Immediately push the stop button, check fan rotation and be sure the fan is not rubbing the housing.
5. If fan rotation is not correct it can be changed as follows:



CAUTION: Turn off and lock the electric power supply to the dryer.

- A. **Three phase motors** – Move the wire from terminal T1 to T3 and T3 to T1 on the fan motor contactor in the motor control cabinet. See Figure 9.

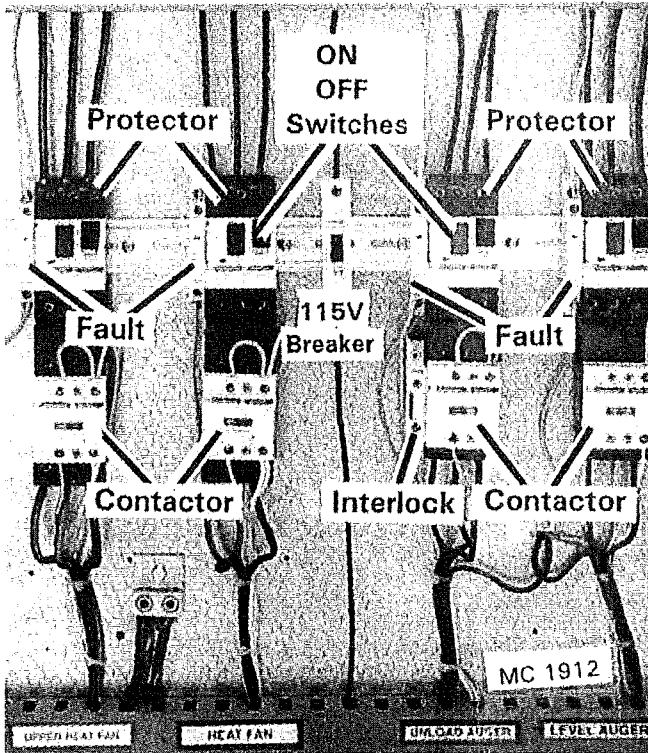

Figure 9 - Fan(s), Level & Unload Auger Motor Controls - 3 Phase 230V (720 Shown)

- B. **Single phase motors** – Refer to the wiring information on the inside of the fan motor junction box cover.

Level and Discharge Auger Rotation

1. Level Auger

- A. Turn Power Switch to the ON position.
- B. With everyone clear of the Fill Auger and Drive Motor, turn Fill Auger Switch to the MANUAL position and check Pulley rotation to make sure that it is clockwise. Turn Fill Auger Switch OFF.

2. Discharge Auger

With everyone clear of the Discharge Auger and Drive Motor, turn Discharge Auger Switch to the ON position. Check the Discharge Auger Pulley rotation to make sure

that it is counterclockwise. Turn Discharge Auger Switch and Power Switch OFF.

3. If rotation of the Level Auger or Discharge Auger is not correct, it can be changed as follows:



CAUTION: Turn off and lock the electric power supply to the dryer.

- A. **Three phase motors** – Move the wire from terminal T1 to T3 and T3 to T1 on the level or unload auger motor contactor in the motor control cabinet. See Figure 10.
- B. **Single phase motors** – Refer to the wiring information on the inside of the level or unload auger motor junction box cover.
- C. Now check rotation again as described above under Level Auger or Discharge Auger.

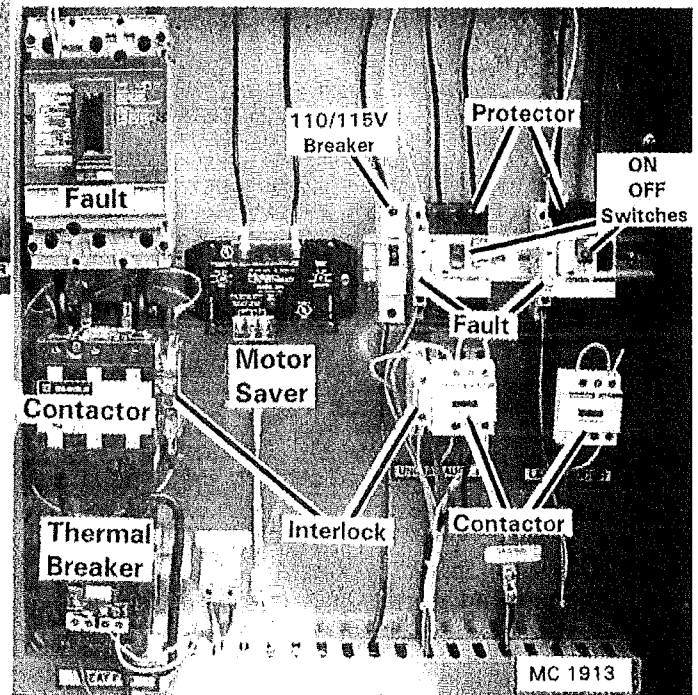

Fig. 10 - Fan, Level & Unload Auger Motor Controls - 1 Phase 230V (520/620 Shown)

Gas Supply and Connections

LP Gas

1. Advise your LP Gas supplier that each dryer burner requires liquid propane from the LP tank (not vapor).

IMPORTANT: Do not store liquid propane in

tanks that have contained anhydrous ammonia. Mixing liquid propane and anhydrous ammonia produces an extremely caustic solution that will damage the dryer controls. It is recommended that only clean LP Gas equipment be used.

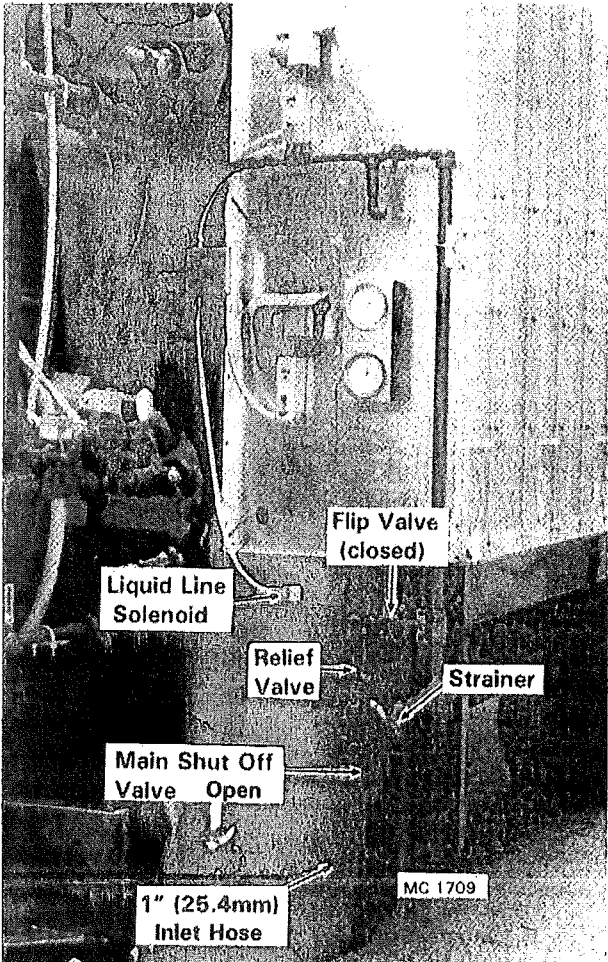

Figure 11 - Liquid Propane Supply Manifold

2. Each burner requires 1-2 psig (6.9-14Kpa) (less in mild weather) of gas pressure at the gauge in the manifold when operating. Always operate dryer with the lowest gas pressure possible that still maintains the selected drying temperature!
3. Consult the LP Gas supplier for gas line size required from the supply tank to the dryer that will provide the amount of fuel to meet the dryer BTU/Hr. requirement at the required operating pressure. See the Gas Consumption (BTU/Hr.) chart.

Gas Consumption BTU/Hr. (KgCal.)*

MODEL	DRY & COOL	ALL HEAT	OPERATING MAXIMUM
CF320	1,562,572 (393,768)	2,404,072 (605,826)	3,111,152 (784,010)
CF410	N/A	2,806,870 (707,331)	3,632,420 (915,369)
CF420	1,642,047 (413,796)	2,526,183 (636,590)	3,269,178 (823,832)
CF520	2,074,204 (522,699)	3,191,155 (804,171)	4,129,730 (1,040,692)
CF620	N/A	3,668,005 (924,337)	4,746,830 (1,196,201)
CF720	2,404,072 (605,826)	4,577,947 (1,153,643)	5,924,402 (1,492,949)
CF730	3,805,450 (958,973)	6,559,960 (1,653,110)	8,489,360 (2,139,319)
CF820	4,407,590 (1,110,713)	7,162,100 (1,804,849)	9,268,600 (2,335,687)

*Approximate BTU/Hr. based on normal drying temperatures at 50°F (10°C) drying shelled corn.

IMPORTANT: Use type of supply line specified by Local Codes.

4. Connect the LP Gas line from the tank valve to the 1" (2.54cm) LP Gas inlet hose at the front of the dryer on the left side (when viewed from rear).

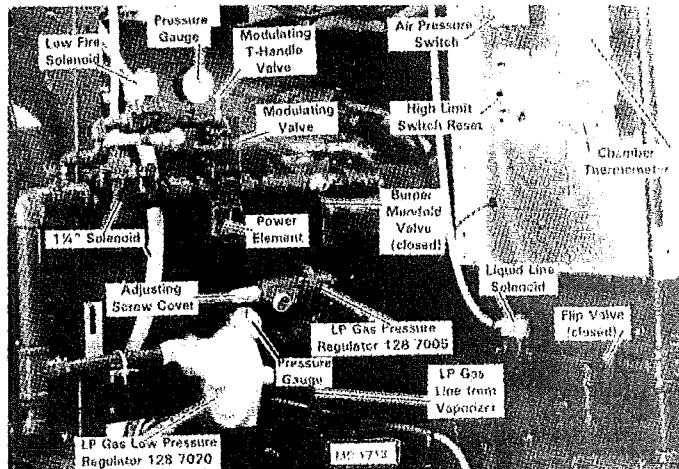

Figure 11A - LP Burner Control Manifold



CAUTION: Before starting the dryer test for any gas leaks. Turn the gas supply on and apply soap water to ALL pipe joints and unions, including pipes assembled on the site and those assembled at the factory.

Natural Gas

1. Each burner requires 1-2 psig (6.9-14Kpa) of gas pressure at the gauge in the manifold when operating.
2. Consult the gas company for gas supply line size required to the dryer that will provide an adequate volume of gas to meet the dryer BTU/Hr. requirement at the required operating pressure. See Gas Consumption (BTU/Hr.) chart.

IMPORTANT: Use type of supply line specified by Local Codes.

Gas pressure for Low Fire Burner Start-Up set at 1/4 psig (1.7Kpa). If gas pressure exceeds 1/4 psig on start-up, reduce pressure by turning Adjustable Orifice screw counterclockwise. If higher gas pressures used, burner ignition may be difficult.

See Figure 12A.

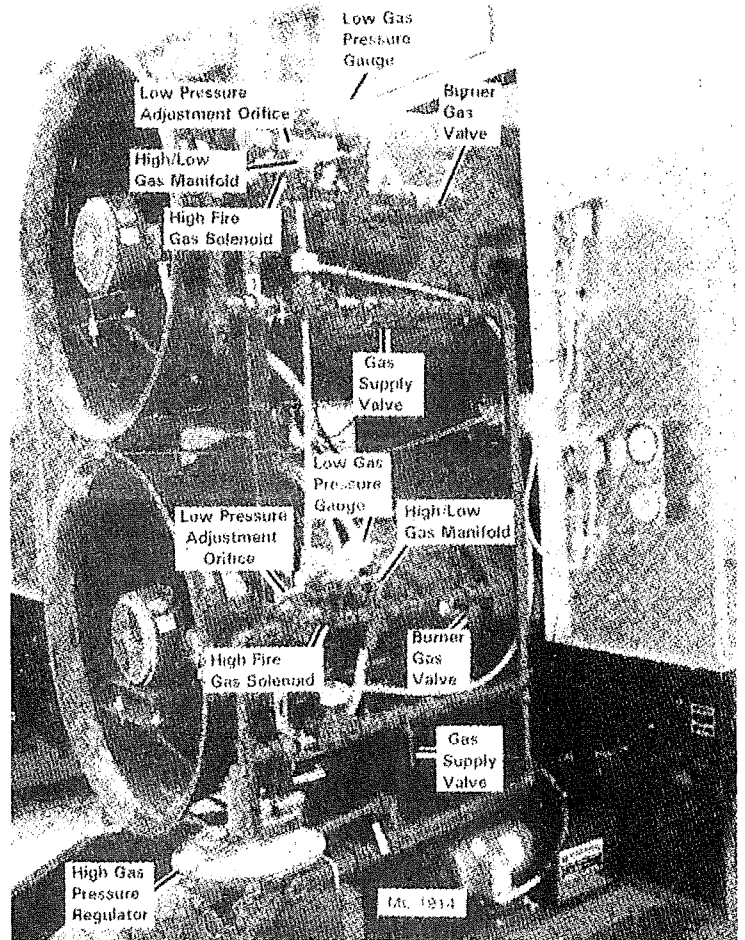

Figure 12 - Natural Gas Supply Manifold

LOW FIRE NAT. GAS MANIFOLD #124 1332

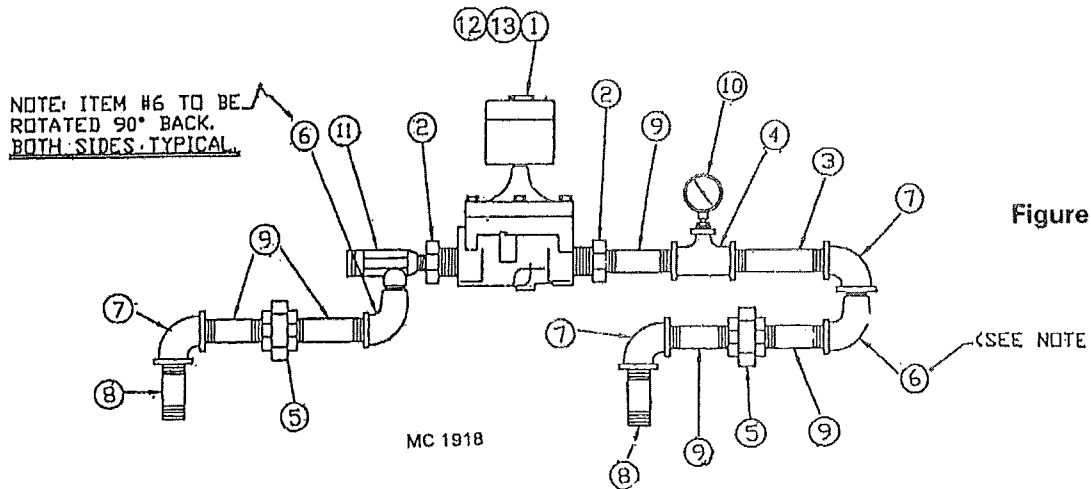

Figure 12A

Ref.	Part No.	Qty.	Description
1	121 7002	1	3/4" (19mm) Solenoid Valve
2	128 5465	2	3/4" x 3/8" (19x9.5mm) Hex Bushing
3	128 5463	1	3/4" x 2" (19.5x50mm) Pipe
4	128 5471	1	3/8", (9.5mm) Tee
5	128 5469	2	3/8" (9.5mm) Union
6	128 5467	2	3/8" (9.5mm) 90° St. Elbow
7	128 5468	3	3/8" (9.5mm) 90° Elbow

Ref.	Part No.	Qty.	Description
8	128 5464	2	3/8" (9.5mm) Close Pipe Nipple
9	128 5462	5	3/8" x 1 1/2" (19x38.1mm) Pipe Nipple
10	120 7007	1	Pressure Gauge 0-3 psig.
11	128 7021	1	Adjustable Orifice
12	122 7035	1	Repair Kit for Ref. #1
13	122 7001	1	Coil for Ref. #1

Moisture Monitor Sensor Installation

1. The Sensor for the Moisture Monitor is shipped fastened to the right rear side of the dryer base. Once dryer is in position at the drying site, the Sensor can be installed. See Figure 13.
2. The rear 8 ft. (2.44m) Discharge Auger Pan has a Cover Plate over the rectangular cutout for the Sensor. The (2) Sensor Brackets #1282769 are used to hold the Cover Plate in place. Remove the (4) #8 sheet metal screws from the (2) Sensor Brackets and discard the Cover Plate. Replace the (2) Sensor Brackets that were just removed.

3. Disconnect the Sensor from the shipping position. The Sensor will be mounted to (2) #1282769 Sensor Brackets that have been attached to the outside bottom of the Auger Pan on each side of the rectangular cutout. Place the Sensor into the cutout and attach Sensor to brackets with (4) #8 x 1/2" (12.7mm) screws.

The ground strap attached to the back of the Sensor can be attached to (1) of the #8 x 1/2" (12.7mm) screws used to mount the Sensor.

There is extra length in the gray flexible conduit containing the (5) wires from the Sensor to provide easy opening of the Auger Pan for clean out.

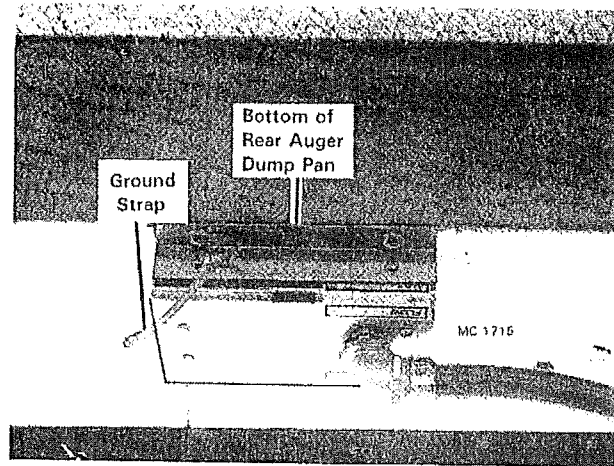

Moisture Monitor Sensor Installation

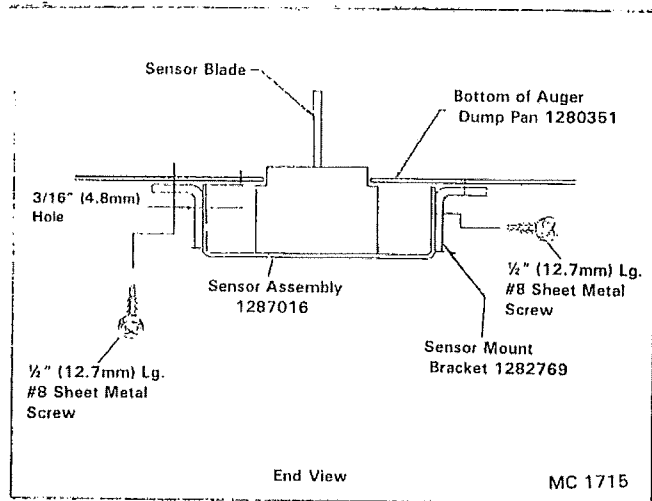

Figure 13 Sensor and Sensor Mounting Brackets

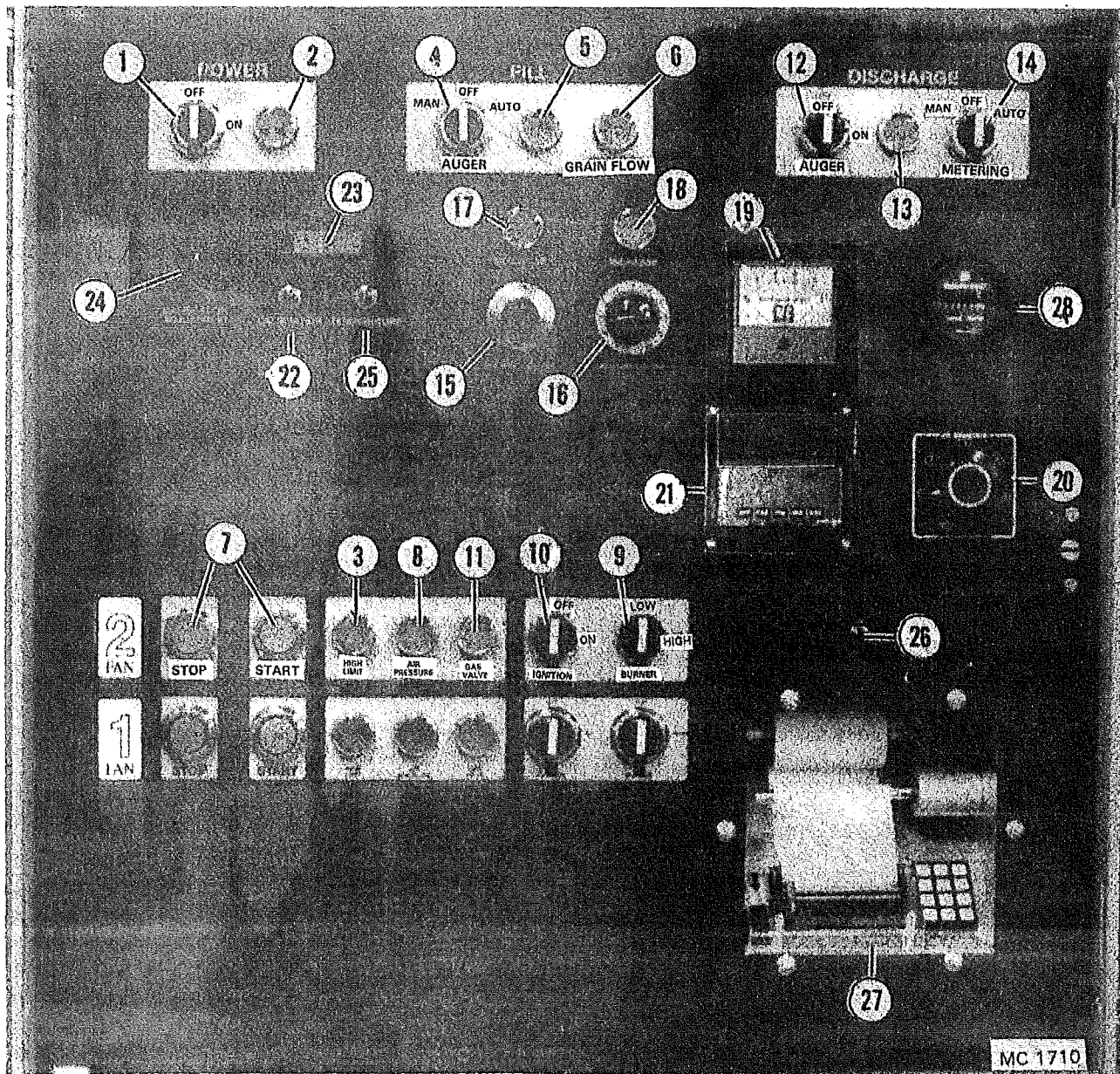

Figure 14

CONTROL PANEL LIGHTS, SWITCHES & CONTROLS

Ref. 1 – Power On Switch

When this spring loaded switch is turned to the ON position, the power on light will be on if the rear discharge overload door is closed, all protector fault interlocks are closed and the main relay is activated. High limit light(s) will also be on. If they are not, push the reset button on the high limit switches.

NOTE: If there is a momentary loss of electricity, the dryer will shut down and the dryer will have to be restarted by turning power on switch to the ON position again.

Ref. 2 – Power On Light

Indicates power on switch has been turned on, discharge overload door, and motor protector fault interlocks are closed, and dryer relay is activated.

Ref. 3 – High Limit Light

Indicates power switch has been turned on and high limit switches are closed.

Ref. 4 – Fill (Level Auger) Switch

Operates Level Auger. When switch is in the Manual position, level auger starts immediately when level switch in hopper is closed and stops when hopper is full and switch is opened.

When switch is in the Automatic position, the grain flow timing circuit is activated.

NOTE: Operation of the Level Auger Circuit is explained on page 28.

Ref. 5 – Level Auger Light

Indicates level auger is turning.

Ref. 6 – Grain Flow Light

Indicates low grain level in wet hopper. Light comes on when Grain Flow Timer reaches zero and dryer is shut down.

Ref. 7 – Fan Start-Stop Buttons

Green Button starts and Red Button stops the fan.

Ref. 8 – Air Pressure Light

Indicates that the air pressure switch is closed, the fan motor contactor(s) is engaged, and the dryer is full of grain.

Ref. 9 – Ignition High/Low Switch

Determines which gas burner solenoids will be operating. Burner must always be started with the switch in the LOW position.

IMPORTANT: Burner must operate on LOW-FIRE for (15) minutes before turning Switch to HIGH-FIRE to allow the temperature modulating valve to warm up slowly.

If the High/Low Switch is turned to HIGH-FIRE too quickly, the heat chamber temperature may rise too fast causing the modulating valve to overreact and close the gas supply to the burner. If the temperature rises above the High Limit Switch setting, the switch will trip out and shut down the dryer.

Ref. 10 – Ignition Switch

Turn this switch to light burner. After a (15) second delay the gas valve light will be ON and the burner will be operating. If the burner does not light in (5) seconds (after the gas valve light comes on), the Ignition Board will "lock out" closing the gas solenoid valves.

Ref. 11 – Gas Valve Light

Indicates that the Ignition Board has supplied power to the gas solenoid valves.

Ref. 12 – Discharge (Unload) Auger Switch

Turn this spring loaded switch to the ON position to start discharge auger. If there is a momentary loss of electricity, the dryer will shut down and the dryer will have to be restarted.

If the discharge auger was operating when the dryer shut down, the Discharge Switch will have to be turned to the ON position again to start the auger.

Ref. 13 – Discharge Auger Light

Indicates that the discharge auger is operating.

Ref. 14 – Discharge Metering Roll Switch

When the switch is turned to the MANUAL position, the SCR drive motor will run constantly and the speed of the motor and metering rolls will be controlled by the Manual SCR Drive Speed Control Dial.

When the switch is in the AUTOMATIC position, the Moisture Control Board will speed up or slow down the SCR direct current drive motor and the metering rolls automatically.

Ref. 15 – Manual SCR Drive Speed Control

This manual speed control is used to adjust the speed of the DC motor that drives the grain metering rolls and changes discharge speed when metering roll switch (Ref. 14) is in the MANUAL POSITION only. Be sure to disengage lock before turning dial.

Ref. 16 – Moisture Control Balance Dial

This balance dial is used to equalize the Moisture Control Decrease and Increase Indicator Lights before turning the discharge metering roll switch to AUTOMATIC.

Once in AUTOMATIC the dial is used to make small adjustments in the moisture content of the discharged grain.

Ref. 17 – Moisture Control Decrease Light

Indicates that the discharge rate is decreasing if Moisture Control is in AUTOMATIC.

Ref. 18 – Moisture Control Increase Light

Indicates that the discharge rate is increasing if Moisture Control is in AUTOMATIC.

Ref. 19 – Discharge Meter

Indicates the rate of discharge when discharge metering roll switch is in the MANUAL or AUTOMATIC position.

Ref. 20 – Selector Switch

This switch is used to select the heat chamber temperature (1 or 2) that will appear on the Digital Thermometer Display Window.

Ref. 21 – Digital Thermometer

This thermometer is an electronic system that provides a remote temperature readout of each heat chamber at the dryer Control Cabinet. Just turn the Selector Switch (20) to the heat chamber number and the temperature will appear on the Digital Thermometer Display Window. Position number (1) is for the bottom heat chamber and position (2) is for the top.

Ref. 22 – Calibration Display Button

Push button to display amount added or subtracted (-9.9 to +9.9) from the discharge grain moisture shown on the digital display meter (23).

Ref. 23 – Digital Display Meter

Displays discharge grain moisture constantly, grain temperature and calibration setting when respective display button is pushed.

Ref. 24 – Calibration Adjustment Dial

Turn dial to change calibration.

Ref. 25 – Temperature Display Button

Push button to display temperature of grain moving over Sensor.

Ref. 26 – Printer ON/OFF Switch

Turns printer on or off.

Ref. 27 – Printer

Provides printed record of time, day, discharge grain moisture, temperature, and average moisture content.

Ref. 28 – Hour Meter

Records hours of dryer operation.

INITIAL START-UP INSTRUCTIONS

General

IMPORTANT: Inspect for and remove any foreign material (nuts, bolts, tools, parts, etc.) from the hopper, grain columns, metering rolls, unload auger and heat chambers before filling the dryer with grain.

1. Turn all switches on the control panel to the OFF position.
2. LP Gas - Close the liquid line flip valve for each burner(s) (handle down). See Figure 15.
3. Close the gas hand valve for burner(s) (handle 90° to the piping). See Figure 16.
4. Check the modulating valve in gas manifold(s) to be sure the "T" handle has not been turned all the way in to the wide open position. See Figure 16. The "T" handle should be halfway between the closed and fully open position.

5. Turn on electric power supply to dryer by pushing the Disconnect Switch Lever Up to the ON position. See Figure 8.
6. Turn the spring loaded Power On Switch to the ON position. The Power On Light will be on if the rear discharge switch, and all protector fault interlocks are closed, and the dryer relay is activated. High Limit Light(s) will also be ON. If not, push the reset button on the high limit switch(es).

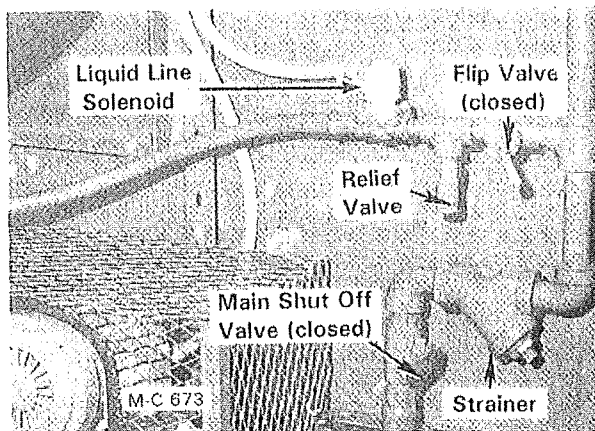

Figure 15

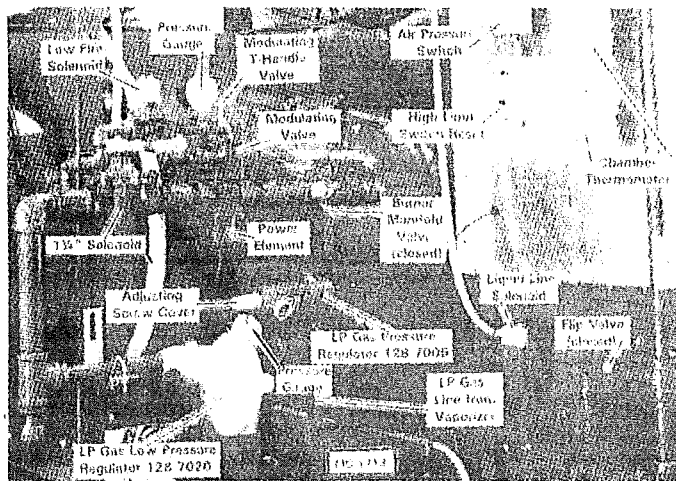

Figure 16

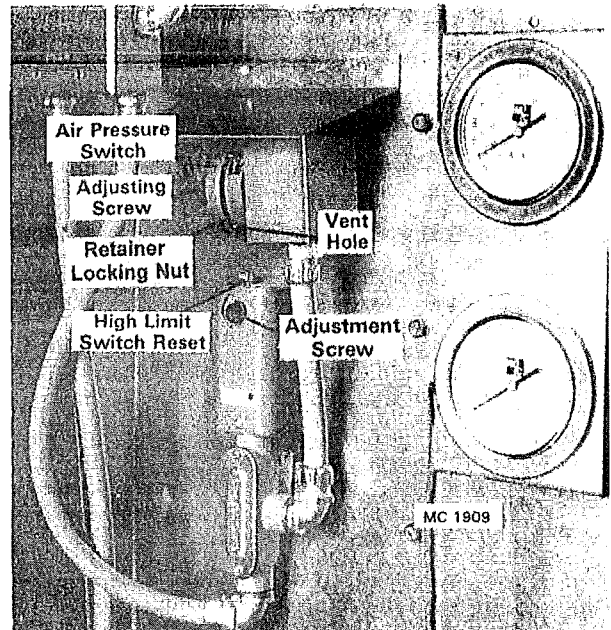

Figure 17

Filling the Dryer



CAUTION: Do not allow anyone to be in the hopper when filling the dryer. **Always** turn off and lock the electric power supply to the control cabinet before allowing anyone to work in the hopper.

1. Turn level auger switch to the MANUAL position. The level auger will start immediately and the level auger light on the control panel will be ON.
2. When the dryer is full, the grain will open the level auger switch in the wet hopper. The level auger will stop and the LEVEL AUGER light will be out.

High Limit Switch

Adjust high limit switch(es) 30° to 50° above operating temperature. This will avoid nuisance shutdowns during start up.

Air Pressure Switch(es)

General

1. There is an air pressure switch for each heat chamber, see Figure 17. The air pressure switch detects static air pressure in the heat chamber when the dryer is full of grain and the fan is running. If the static air pressure drops because of fan failure, the air pressure switch opens stopping current flow to the ignition switch. The gas

solenoid valves will close and the burner will shut down.

2. The air pressure switch is designed to protect the dryer from fire that may result from fan (air flow) failure while burner is operating.



CAUTION: This safety feature is for your protection and protection of the dryer. The air pressure switch should be checked for correct operation at the start of the drying season and periodically during the season.

Checking

1. After the dryer has been filled and before a burner is started, the operation of the air pressure switch **MUST** be checked. Be sure the rear doors are closed.
2. Start the fan(s).

NOTE: The Manual Motor Protector Fault Interlocks are wired in series. If (1) manual motor protector thermally or magnetically trips, the dryer will shut down and all indicator lights will be out. When the manual motor protector is reset (black toggle switch pushed in), the spring loaded Power On Switch will have to be turned to the ON position. The Power On Light and High Limit Light(s) will light. At this time each fan can be restarted.

3. The air pressure light on the control panel will come ON as each fan comes up to speed.

- If the light does not come ON or comes ON too soon (before the fan comes up to speed) the air pressure switch must be adjusted.

Adjusting

NOTE: The fan(s) must be running before the air pressure switch(es) can be accurately adjusted.

- Remove the plastic cap on the air pressure switch. The slotted screw is the adjusting screw. See Figure 17.
- Turn the adjusting screw in (clockwise) until the air pressure light goes out.
- Turn the adjusting screw out (counterclockwise) until the air pressure light comes ON. After the air pressure light comes ON, turn the adjusting screw out an additional $\frac{1}{2}$ turn to allow for normal changes in static pressure.
- Shut off the fan(s). The air pressure light will go out when the fan stop button is pushed. These dryers are wired so that the power flows from the fan start button to the air pressure switch.
- If all air pressure switch adjustment is used and the air pressure light does not light, it should be removed and checked.



CAUTION: Turn off and lock the electric power supply to the dryer.

- Remove the Air Pressure Switch Weather Cover and then the (2) wires from the air pressure switch power terminals. Check continuity of the (2) wires. If wires are okay, remove air pressure switch from tube and filter assembly. Check to be sure that the $\frac{1}{8}$ " (3.2mm.) vent hole in the bottom of switch is open. Then check for an obstruction in the air pressure tube and filter assembly. See Figure 18. Now replace air pressure switch, (2) wires, and weather cover that were removed above.
- Turn on power and start fan(s) and check operation of switch. If air pressure light is blinking, turn the adjusting screw out until light stays on.
- If light does not come on, it will be necessary to replace air pressure switch and check operation of new switch.

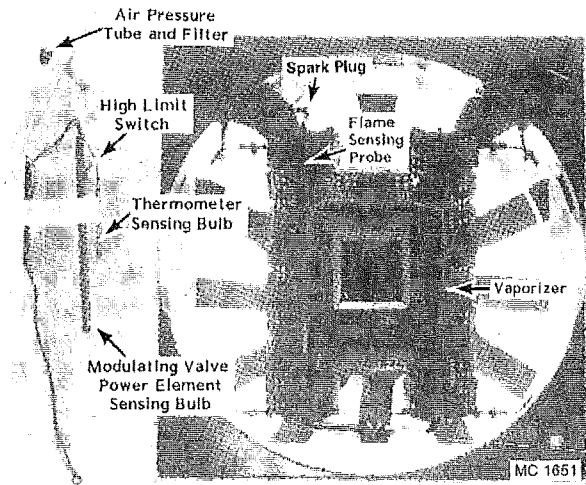

Figure 18 - 6 MBTU LP Burner - 620 & 820 Top

Starting the Burner(s)

NOTE: Each burner is equipped with a high-low switch that is located on the control panel to the right of the ignition switch.

When starting the burner(s) the high-low switch must be placed into the LOW position before turning the ignition switch to the ON position. The LOW position prevents freezing of the LP gas line and keeps the temperature from rising too fast. Switch should remain in LOW for at least (10) minutes before turning to HIGH. If the temperature rises too rapidly, the high limit switch will open and the dryer will shut down.

- LP Gas** - Open the supply valve at the tank and lift up on the dryer liquid line Flip Valve(s) located after the strainer. See Figure 15. The flip valve is open when the handle is 90° to the piping.

Natural Gas - Open the supply valve.

- Start the fan(s).
- Be sure high-low switch is in the LOW position. Open the burner gas manifold hand valve (Figure 16) all the way until it stops at preset position. Turn the burner ignition switch to the ON position. After a (15) second delay the gas valve light will be ON and the burner will light.

NOTE: The (15) second delay before ignition is a safety feature that allows the fan to purge the heat chamber of any unburned gas that may remain after a burner has been shut down for any reason.

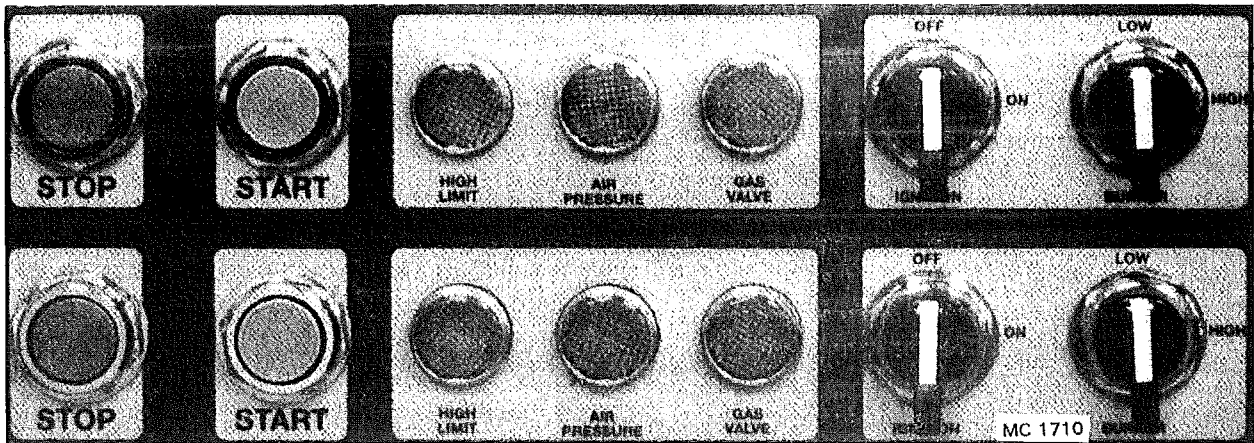

Figure 19

4. If the LP gas line freezes, close the gas hand valve and turn the ignition switch OFF. After the gas line thaws repeat step 3.

NOTE: The ignition board is electronically timed so that the ignition system will continue to spark and hold the solenoid gas valves open for a "trial ignition" period (about 5 seconds). If the burner does not light, the system will "lock out" (after the 5 second trial period) closing the solenoid gas valves. The gas valve light will be out.

5. If after several attempts for ignition there is still no flame, it may be that the built-in circuit breaker of the ignition board has opened from heat build-up due to repeated ignition attempts. Wait about (5) minutes before trying to start burner again. However, failure to obtain burner ignition may be due to incorrect gas pressures.

IF AN LP BURNER, check gas pressure on the high pressure gauge to the left of the High Pressure Regulator. Gauge should read **(12) psig (82 kPa)**. If not, remove plastic cover from pressure regulator, loosen locknut, and turn adjusting screw until **(12) psig (82 kPa)** appears on gauge.

Now check the low gas pressure gauge on the Low Fire Gas manifold to the left of the modulating valve. The gauge should read from **(½) to (¾) psig (3.44 to 5.2 kPa)** when burner is operating in the Low Fire mode. The burner low gas pressure is set by adjusting the low pressure regulator that is just to the left of the high pressure regulator.

The low gas pressure should be set at between **(1.5 to 2) psig (10 to 13.9 kPa)**, but only when the burner is operating at High Fire. To set pressure remove cover from low pressure regulator and use special 9/16" (14.3mm) Allen wrench supplied with dryer.

IF A NATURAL GAS BURNER, check gas pressure on the low pressure gauge on the High/Low Fire Gas Manifold to the left of the modulating valve. The gas pressure should be no more than **(¼) psig (1.7 kPa)** when the burner is operating at Low Fire.

To adjust the low gas pressure, remove the cap at the end of the Adjustable Orifice Body using a 5/32" (3.97mm) Allen wrench which will also be used to adjust the orifice inside the body. Gas pressure should only be adjusted when burner is operating at High Fire. A gas pressure of **(1.25) to (1.50) psig (8 to 10 kPa)** at High Fire should produce a gas pressure of **(¼) psig (1.7 kPa)** at Low Fire. A pressure of more than **(¼) psig (1.7 kPa)** at Low Fire will make burner ignition difficult.

Pressures may have to be increased when drying during low outside temperatures.

6. If the burner fails to light, Turn Off and Lock Electric Power Supply to the dryer. Review the Direct Spark Ignition explanation on page 46. Then check for a burned or broken wire or a loose or corroded connector. Be sure tip of spark plug is dry and electrode gap is correct - .062" (1.6mm).

7. Unlock and turn on the electric power supply to the dryer. Turn Power On Switch to the ON position. Restart fan(s) and repeat step 3.

NOTE: When a High Limit Switch trips out, the dryer will shut down. Fan(s) and burner(s) will have to be restarted.

8. If the high limit switch trips out, close the gas hand valve and turn the ignition switch OFF. Push the reset button on the high limit switch to reset it. See Figure 17. Adjust high limit 30° to 50° above operating temperature. This will avoid nuisance shutdowns during start up.

9. **LP Gas Only** - When the flame is established, the heat causes the LP gas to vaporize. After the burner has been running for 10 minutes check the vaporizer as follows:

- A. Check the LP gas line coming out of the fan housing from the vaporizer to the pressure regulator with your hand. See Figure 23.



CAUTION: The line may be very hot.

- B. When the vaporizer is positioned correctly in the flame, the LP gas line coming out of the fan housing from the vaporizer to the pressure regulator should feel very warm, but not so hot that you cannot hold your hand on it.
- C. If it feels cool, the vaporizer is not close enough to the flame. If it is very hot, the vaporizer is too close to the flame.
- D. Shut off the burner and fan.



CAUTION: Turn off and lock the electric power supply to the control cabinet, close liquid line flip valve and main gas hand valve.

- E. **Adjusting Vaporizer:** At the bottom of the fan housing there is a vaporizer adjusting plate that is held in place by (2) bolts. To adjust vaporizer the (2) bolts have to be loosened. Once bolts are loose, enter the plenum (heat) chamber and move the vaporizer closer to or away from burner. Now exit heat chamber being sure to close door and tighten (2) bolts securing vaporizer plate. See Figure 21.

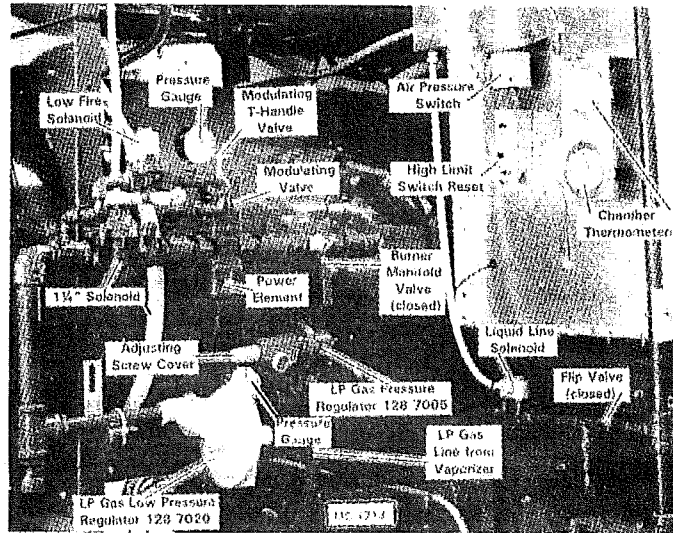

Figure 20

- F. After adjustment is made, turn on electric power, open liquid line flip valve and main hand valve. Now restart fan(s) and burner and check temperature of vaporizer piping.

NOTE: After the dryer has been operating for several hours, check the gas pressure gauge and make any corrections. Always operate the burner(s) with the lowest gas pressure possible that maintains the selected drying temperature.

NOTE: After the dryer has been operating for several hours, check the gas pressure gauge and make any corrections. Always operate the burner(s) with the lowest gas pressure possible that maintains the selected drying temperature.

Setting Burner Operating Temperature

NOTE: Refer to the "Suggested Burner Operating Temperature Setting Chart." See Figure 22. Temperatures shown are initial settings and may have to be adjusted for local crop and weather conditions. **At no time should the Dryer Plenum (Heat Chamber) Temperature exceed 290°F (143°C).**

1. With the burners operating, set the operating temperature by adjusting the modulating valve.
2. There is a Mechanical Thermometer for each heat chamber. This thermometer is attached to the left front end panel of the dryer. See Figure 23. There is also a Digital

Thermometer Display Window located on the Control Panel of the dryer Control Cabinet (lower). Just turn the Selector Switch to heat chamber number wanted (1 or 2) and check display window for temperature.

- After the burner(s) operating temperature(s) has been set, close the hand valve(s), turn the ignition switch(es) off and turn off the fan(s).

Suggested Burner Operating Temperature Settings °F (°C)

IMPORTANT: Use this chart as a starting point for drying the crops listed. Depending on the condition of the crop, you may have to increase or decrease the temperature shown. When drying seed grain, use lower temperatures.

DRYER MODEL	MAIZE (CORN)		SORGHUM & WHEAT		RAPE (CANOLA), SUNFLOWERS, DATS, BARLEY, SOYBEANS	
	DRY & COOL	ALL HEAT	DRY & COOL	ALL HEAT	DRY & COOL	ALL HEAT
CF320, 420, & 520	230 (110)	235 (113)	170 (77)	170 (77)	140 (60)	140 (60)
	COOL		COOL		COOL	
CF410 & 620	-	235 (113)	-	170 (77)	-	140 (60)
CF720, 730, & 820	230 (110)	235 (113)	170 (77)	170 (77)	140 (60)	140 (60)
	COOL	200 (93)	COOL	150 (60)	COOL	130 (54)

Figure 22

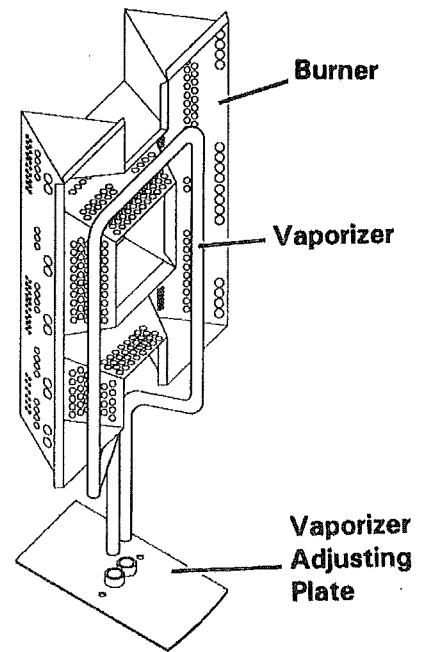

MC 1655

Figure 21 - LP Gas Burner & Vaporizer

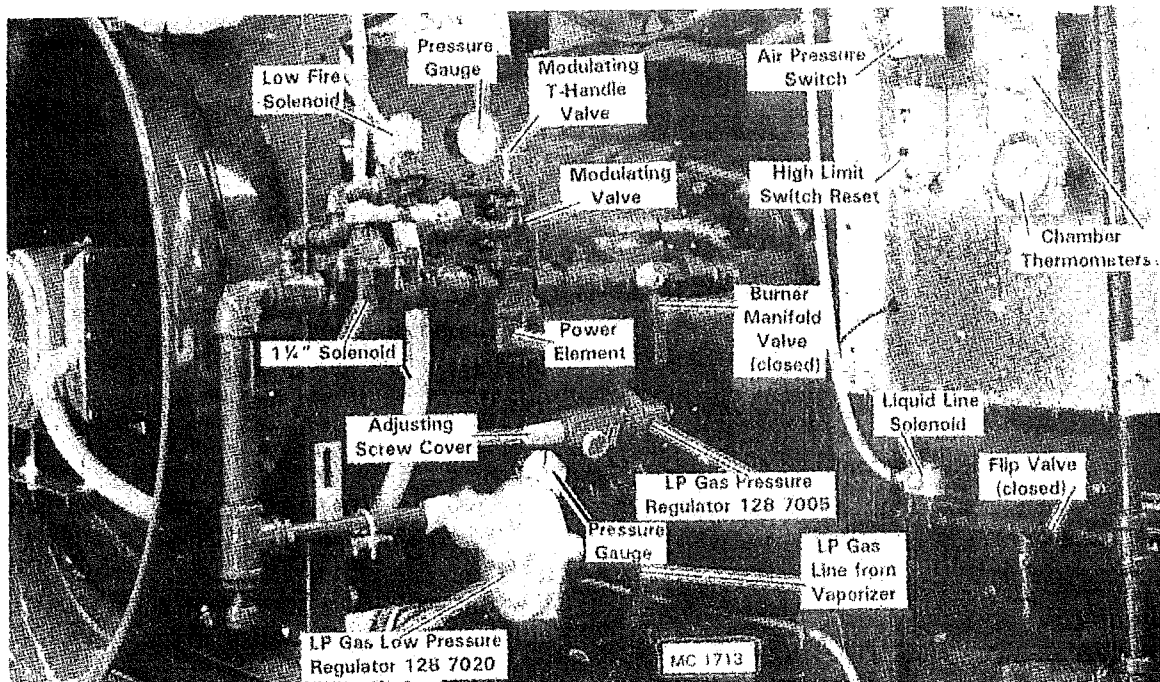

Figure 23

OPERATING INSTRUCTIONS

Level Auger Operation

Description

There is an adjustable 0 to 3 minute delay in the level auger circuit. See Figure 24. It is activated when the level auger switch is in the AUTOMATIC position and the level auger light is signaling for grain.

This delay prevents nuisance starting and stopping of the level auger. If the level auger switch is turned to OFF and back to the AUTOMATIC position, the delay will recycle.

The Grain Flow Timer, Figure 24, will shut the dryer down if there is an insufficient grain supply to fill the hopper. When the level auger starts, the Grain Flow Timer will be activated. When the timer counts down to zero, the dryer will shut down and the Grain Flow light will come on.

Setting the Grain Flow Timer

IMPORTANT: If the timer has not been set, the dryer will shut down when the level auger switch is turned from MANUAL to AUTOMATIC.

1. Set the adjustable level auger delay, Figure 24, for time desired (0 to 3 minutes).
2. Set the Grain Flow Timer arrows at the bottom of the timer face to X10 (times ten) and to M (minutes). It may be necessary to remove the timer from its socket to make this adjustment. Now turn the timer control knob to 3 (3x10) or 30 minutes and turn the level auger switch to AUTOMATIC. The level auger will start and the level auger light will come ON after the 0 to 3 minute delay if the level auger switch in the wet hopper is signaling for grain.
3. Check the time that it takes the level auger to refill the wet hopper (6) times. The length of time that the level auger light is ON plus the 0 to 3 minute delay is the refill time.
4. Average the 6 refill times and reset the Grain Flow Timer, Figure 24, to run 5 minutes longer. For example, if it takes the level auger an average of 5 minutes to refill the dryer, set the Grain Flow Timer to run 10 minutes.

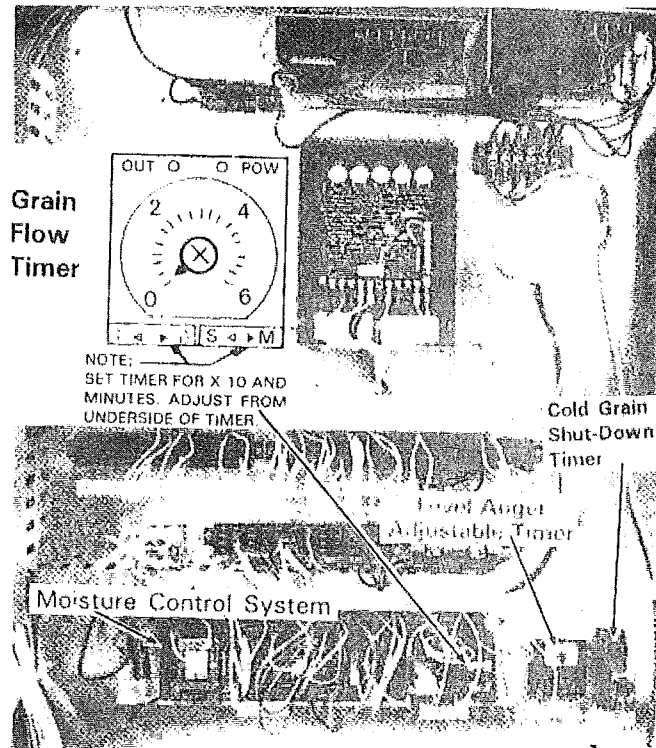

Figure 24

5. The level auger should start before the grain level appearing in the front View Lens of the wet holding hopper only covers the bottom half of the Lens. See Figure 25.

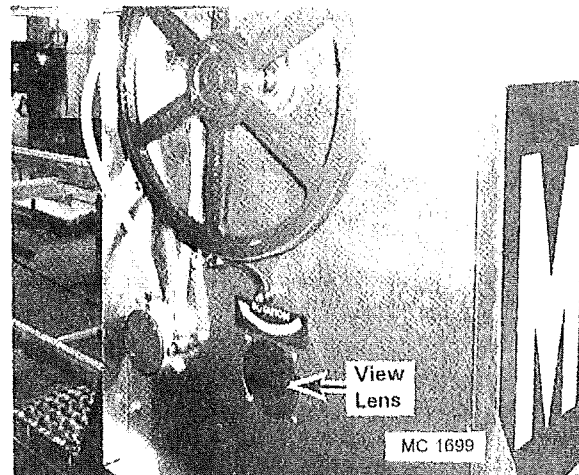

Figure 25

If the grain level drops below the entire View Lens before the level auger starts, the auger may not provide enough wet grain to fill the hopper and will run constantly until the Grain Flow Timer locks out and the dryer is shut down (if level auger switch in AUTO).

Keeping the wet hopper full of grain is essential for maximum drying capacity and helps to reduce fuel consumption.

NOTE: The timer does not operate when the level auger toggle switch is in the **MANUAL** or **OFF** position.

Grain Flow Timer Operation

With the Grain Flow Timer set to run 5 minutes longer than the wet hopper refilling time, the timer will work as follows:

1. The timer will start when the level auger starts. The red light on the face of the timer will be on and the timer will start to count down to zero.
2. After the level auger refills the dryer and shuts off, the level auger light will go out and the timer will automatically reset. The red light on the face of the timer will be out.
3. If there is an insufficient grain supply, the level auger will continue to run beyond the 5 minute refilling period. When the level auger has run the length of time that the Grain Flow Timer has been set, the dryer will shut down.
4. The grain flow, high limit, and the two red lights at the top of the Grain Flow Timer will be on. Turn the level auger switch **OFF**.

NOTE: When the Grain Flow Timer shuts the dryer down, determine the problem.



CAUTION: Turn off and lock the electric power supply to the dryer before any service work is performed.

5. When the problem has been corrected, turn on power supply to dryer. Now turn dryer Power On Switch to **OFF**, then to the **ON** position and release it to reset the Grain Flow Timer. The Power On Light will light.
6. Turn the level auger switch to **MANUAL** and refill dryer. Restart the fan(s), burner(s), and the discharge auger. Turn the level auger switch to the **AUTOMATIC** position. The level auger 0 to 3 minute delay will be activated if the level auger switch in the wet hopper is signaling for grain.



CAUTION: Do not allow anyone to be in the hopper as the level auger will start automatically.

Operation of the Discharge System

(See Figures 26 thru 30)

The unload (discharge) auger and metering rolls are used to unload grain from the dryer. The unload auger operates at a constant speed while the metering roll speed can vary depending upon the speed of the DC motor that drives the metering rolls.

1. The discharge auger spring loaded switch must be turned to the **START** position and released so that it will move to the **ON** position and start the auger before the metering roll switch is activated. This prevents the metering rolls from dumping grain onto a stopped discharge auger. If the electricity to the dryer is interrupted for any reason, the discharge auger switch will lock out and must be turned to the **START** position and released to restart the discharge auger and metering rolls.
2. The grain metering rolls are driven by a 1/3HP direct current motor and gearbox. The speed of the motor when the metering roll switch is in **MANUAL** is controlled by a potentiometer (SCR drive speed control) located on the control door. The speed control dial is graduated from 0 (slow) to 10 (fast).
3. When the discharge metering roll switch is in the **AUTOMATIC** position, the automatic moisture control determines the speed of the 1/3HP DC drive motor and the discharge metering rolls in response to grain temperature changes.
4. A rear discharge overload door at the top rear of the discharge auger is provided in case the customer supplied grain take-away system fails. If such a failure occurs, the dryer will continue to discharge grain until the rear discharge overload door is raised by the excess grain.

When the overload door rises, the unload switch opens, the dryer shuts down, and all of the indicator lights will be out except the high limit light(s). The grain flow timer will automatically reset. When the problem has been corrected and the rear discharge overload door closes, the Power On Switch will have to be turned to the **ON** position and released. The Power On Light will light. The

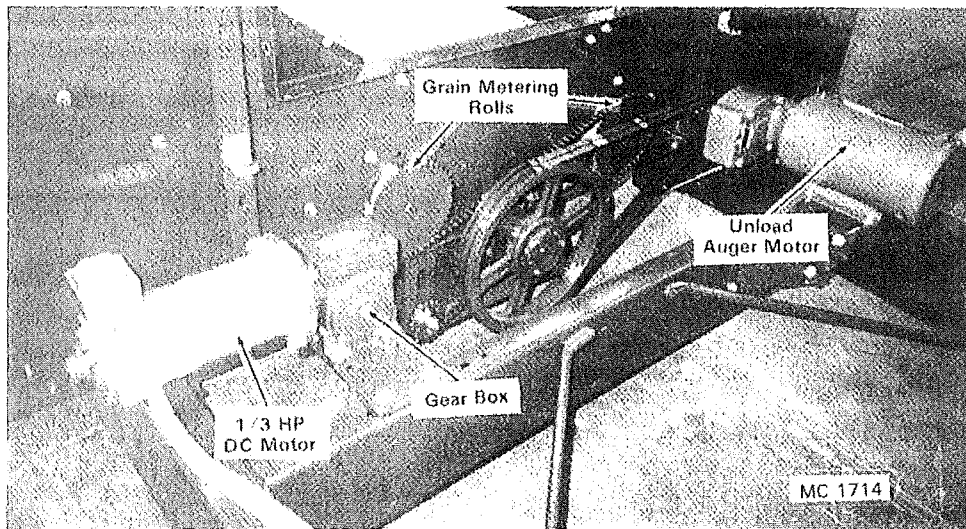

Figure 26

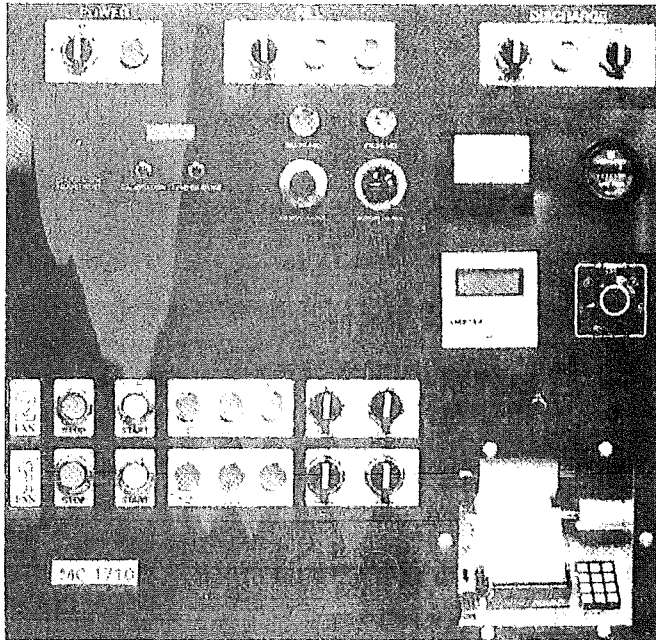

Figure 27

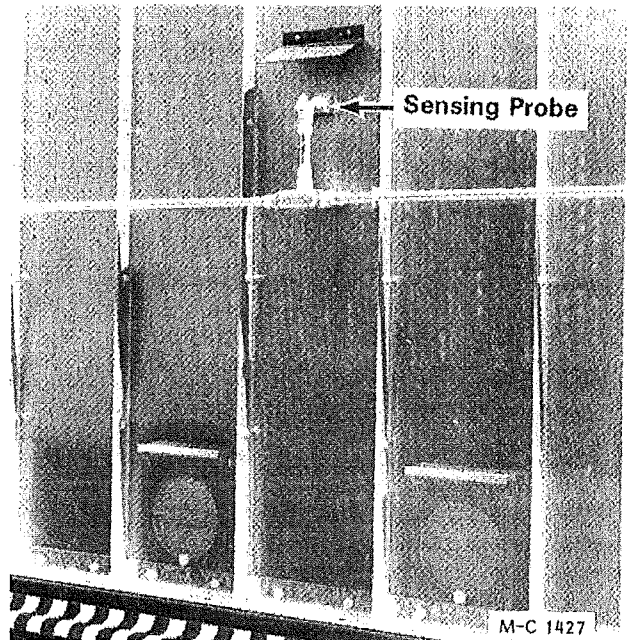

Figure 28

level auger delay will also be activated if the level auger switch is in the AUTOMATIC position and the level switch in the hopper is signaling for grain.



CAUTION: Do not allow anyone to be in the hopper as the level auger will start automatically.

Turn the ignition switch(es) OFF and restart the fan(s), burner(s) and discharge auger.

Automatic Moisture Control System

There is a direct relationship between grain temperature and grain moisture and any change in grain temperature will mean a change in grain

moisture. If the temperature of the grain goes down, the moisture content will have increased. If the temperature of the grain goes up, the moisture content will have gone down.

The automatic moisture control on M-C Dryers maintains uniform moisture content of the grain being discharged from the dryer by changing the unloading speed of the dryer.

The moisture control is sensing grain temperature and reacting to it by slowing down or speeding up the unload rate of the metering rolls.

Drying Grain

1. Turn all of the switches on the control panel to the OFF position.
2. Turn on the electric power supply to the dryer. Now push the Quick Disconnect Switch (top right front corner of motor control cabinet) up to the ON position.
3. Turn the spring loaded Power On Switch to the ON position. The Power On Light and High Limit Light(s) will light.
4. Turn the Level Auger Switch to the MANUAL position. Be sure to set the Level Auger Delay and the Grain Flow Timer as explained on page 28
5. With the dryer full of grain, turn the Level Auger Switch to AUTOMATIC and start the bottom fan. When it comes up to speed, start the next fan.

NOTE: If the dryer is to be operated "Dry and Cool" it is suggested that the lower burner be started and run until the first load of grain is dry to avoid having to recycle the wet grain in the cooling section back to the heating section.

6. Start the burner(s) in order from the bottom to the top.
7. Running on continuous heat, it will take approximately 6 minutes per point of moisture being removed to dry the first load.
8. When the first load is dry, turn the Discharge Auger Spring Loaded Switch to the ON position and release it.
9. Turn the Discharge Metering Roll Switch to the MANUAL position. The SCR drive motor will start and the dryer will begin unloading grain.
10. The SCR Drive Speed Control Dial, Figure 27, is graduated from 0 (slow) to 10 (fast). Use the Grain Metering Roll Discharge Rate Chart, Figure 29, as a guide to set the SCR Drive Speed Control.
11. Test the moisture content of the grain being discharged every 15 minutes until it stabilizes. Use grain sampler on unload auger discharge housing. See Figure 30.
12. If the moisture content is too high after it stabilizes, turn the SCR Drive Speed Control down to a lower number to decrease the unloading speed. If it is too low, turn the speed control up to a higher number to increase the unloading speed. Avoid over adjusting. Make small changes in dial setting. Then wait (1) hour to allow dryer to react before making any further changes.

Switching from Manual to Automatic

1. Before placing the discharge metering roll switch into automatic position, the dryer must be operated in the MANUAL position. Set the manual SCR speed control to establish a discharge rate that will unload dry grain at the desired moisture content. See Figure 29. When the moisture content of the discharged grain has been consistent for two or more hours, it is time to switch to AUTOMATIC.
2. While the discharge metering roll switch is in MANUAL, turn the moisture control dial to balance the Moisture Control to the point where both the decrease and increase lights are off. At this point the Moisture Control is calibrated to the moisture content established in the MANUAL setting.
3. Now turn the metering roll switch to the AUTOMATIC position.

The manual SCR speed control is OFF and the discharge rate is being controlled by the Moisture Control board and the thermistor (sensing probe).

The unloading speed on the discharge meter indicator should be the same as when the switch was in MANUAL, but the meter will begin to change automatically.

When the moisture content of the incoming grain changes (wetter or drier), the discharge rate will change automatically. If the speed slows down because the incoming grain is wetter, the decrease light will come on and the discharge meter indicator will drop until the unload speed is automatically adjusted. When the adjustment is completed, the decrease light will go out and the discharge meter indicator and the unload speed will remain constant until another change is required.

Start-Up SCR Manual Drive Speed Settings

NOTE: These dial settings are not final and are based on normal drying temperature (see page 27). Exact settings will vary with outside temperatures, humidity, crop maturity, variety, cleanliness of grain, test weight, drying temperatures, etc. All values based on 70 volts as SCR maximum voltage. Under 0.5 setting of SCR dial, voltage to SCR motor may become inadequate to properly turn loaded feed rolls. Care should be taken when operating at these low speeds.

Sprocket Gear Ratio: 266:1

CROP AND DRYING MODE	MOISTURE REMOVAL	SCR SETTING MODEL							
		320	410	420	520	620	720	730	820
Corn Dry & Cool	20% - 15%	4.2		3.8	3.7		3.7	3.7	3.8
Corn Dry & Cool	25% - 15%	2.6		3.8	2.3		2.3	2.5	2.7
Corn All Heat	20% - 15%	7.8	7.0	7.0	6.0	6.0	6.0	6.2	7.1
Corn All Heat	25% - 15%	4.6	4.6	4.6	4.6	4.6	4.6	4.5	4.4
Wheat Dry & Cool	17% - 12%	4.7		4.1	3.9		3.9	4.0	2.5
Sorghum Dry & Cool	20% - 15%	4.2		3.8	3.5		3.5	3.5	2.2

Figure 29

If the discharge speed increases because the incoming grain is drier, the increase light will come on and the discharge meter indicator will move up until the unload speed is automatically adjusted. When the adjustment is completed, the increase light will go out and the discharge meter indicator and the unload speed will remain constant until another change is required.

The system will automatically change speed (increase or decrease) to keep the discharge grain at the moisture content that was selected when the metering roll switch was in the MANUAL position.

Moisture Control Setting and Adjustments When in Automatic

The discharge rate will change to keep moisture content the same as when in manual. However, if you want to change the discharge moisture content when operating in automatic, simply turn the moisture control dial up to a higher number for drier grain or down to a lower number for wetter grain. When you turn the dial either the increase light or the decrease light will come on and you will see the discharge meter indicator change to reflect the change in speed.

Cold Grain Shut-Down Timer

This 0 to 60 minute timer is provided to limit the time that the dryer will discharge grain after the burner unexpectedly goes out (lack of fuel, etc.).

The timer is only activated when the Discharge Metering Roll Switch is in the automatic position and the Moisture Control System reduces the speed of the metering rolls. At this time one of the red lights on the face of the timer will be on and the timer will start to move to zero.

If the speed of the metering rolls is not increased before the time selected on the timer is reached, the dryer will be shut down and only the 115V high limit light(s) will be on.

Set the timer arrows at the bottom of the timer face to X10 (times ten) and to M (minutes). Now turn

the time control knob to 3 (3x10) or 30 minutes for a starting point, see Figure 24.

End of Day Shutdown

1. To shut off the dryer, close the liquid propane gas supply valve at the tank or close the natural gas supply valve. Operate burner(s) until the flame goes out then turn off ignition switch(es).
2. Close gas main hand valve and liquid line flip valve on dryers equipped with liquid propane (LP) burner(s).
3. To make next day start-up much easier, be sure to set the Manual SCR Dial to match the reading on the discharge meter before placing the Metering Roll Switch into the OFF position from automatic.

After at least one minute place the Discharge Auger and Level Auger Switches into the OFF position.

4. Operate fan(s) about 15 to 20 minutes to cool grain in dryer, then turn off fan and turn the Power On Switch to the OFF position.
5. Turn off and lock the electric power supply to the dryer.

Next Day Start-Up

1. Turn on electrical power to dryer, turn the Power On Switch to START, place Level Auger Switch into AUTOMATIC, and start fan(s).

2. Open liquid propane gas supply valve at tank or natural gas supply valve and liquid line flip valve(s) on dryers equipped with liquid propane burner(s).
3. Open burner gas main hand valve ¼ of the way and turn the Burner Ignition Switch ON. After flame is established, slowly open burner main gas hand valve all the way.
4. Heat grain for (5-10) minutes then place Discharge Auger Switch into ON position and Discharge Metering Roll Switch into MANUAL. Discharge Grain for (30) minutes then place Metering Roll Switch into AUTOMATIC. **DO NOT RE-BALANCE THE MOISTURE CONTROL SYSTEM!**

Going Back to Manual

You can switch back to manual at any time. Just turn the metering roll switch to the MANUAL position. At this time the Moisture Control will be off and the discharge metering roll speed will be controlled by the manual SCR drive speed control. The discharge meter dial will indicate the manual speed setting. If you want to unload at the same speed in manual as automatic, adjust the SCR drive speed control until the discharge meter indicator is at the same reading as it was in automatic.

When operating in manual the increase and decrease lights may be lit. However, they are only indicating what would happen if you were in automatic based on the set point of the moisture control knob. When in manual you can balance the increase and decrease lights. However, unless you go to the automatic position nothing will change. In the manual position the discharge rate can only be changed by adjusting the SCR speed control dial.

Rear Discharge Overload Door

1. If the customer supplied grain take away system fails, the dryer will continue to discharge grain until the rear discharge overload door, Figure 30, is raised by the grain.
2. When the overload door rises, the dryer will shut down and all of the lights except the 115V heat bulb will be out. The Grain Flow Timer will automatically reset.

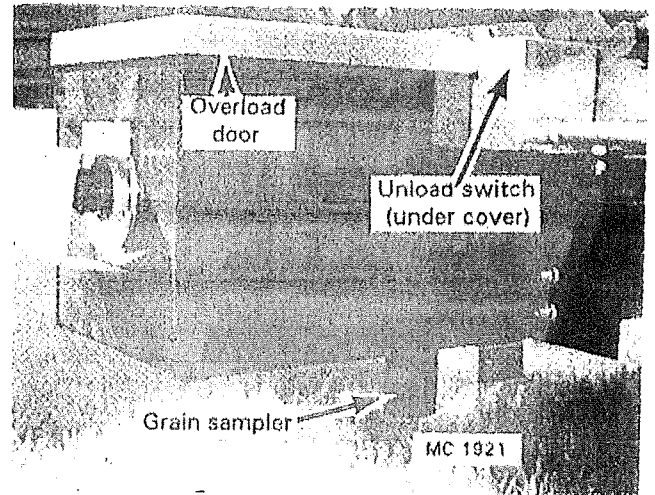
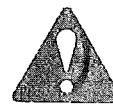

Figure 30

3. When the problem has been corrected and the rear discharge overload door closes, the high limit light will be on. Turn Power On Switch to the ON position and release, the Power On light will light.
4. The level auger delay will be activated if the level auger switch is in the AUTOMATIC position and the level auger switch in the wet hopper is signaling for grain.



CAUTION: Do not allow anyone to be in the hopper as the level auger will start automatically.

5. Turn the ignition switch(es) OFF and restart the fans, burner(s) and discharge auger.

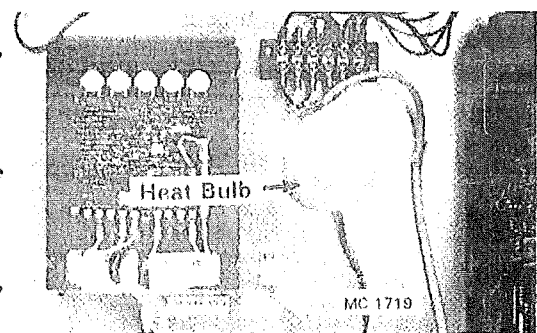

Figure 31

Control Cabinet Heat Bulb

1. The heat bulb in the remote control cabinet, Figure 31, will always be on when the electric power supply to the dryer is on. It does not have an ON-OFF switch.
2. The bulb supplies heat to help keep the electrical components in the cabinet dry.

Temporary Shut Down

1. Close the LP Gas supply valve at the tank or close the natural gas supply valve. Operate the burner(s) until the flame goes out. Turn the ignition switches OFF.
2. Close the burner gas main hand valve(s) (handles 90° to the piping).
3. **LP Gas** - Close the liquid line flip valve for each burner (handle down) and the hand valve at the LP Gas inlet hose.
4. Turn the discharge metering roll, level auger and discharge auger switches OFF.
5. Run the fan(s) approximately 20 minutes to cool the grain in the dryer, then turn off fan(s) and turn the Power On switch to OFF.
6. Turn off and lock the electric power supply to the dryer.

Restarts

1. Turn all switches on the control panel to the OFF position. Turn on the electric power supply to the dryer.
2. **LP Gas** - Open the tank supply valve, hand valve at the LP gas inlet hose and the liquid line flip valve for each burner.
3. **Natural Gas** - Open the gas supply valve.
4. Turn the Power On switch to the ON position and release it.
5. Start the bottom fan. When it comes up to speed, start the top fan.
6. Start the burner(s). Turn the level auger switch to AUTOMATIC.
7. Turn the discharge auger spring loaded switch to ON and release it.
8. Turn the discharge metering roll switch to the AUTOMATIC position to begin discharging grain.
9. The moisture control will automatically control the metering rolls to maintain the desired moisture content.



CAUTION: If the outside temperature dropped below freezing (32°F) after the dryer was shut down, check to be

sure that the grain in the lower part of the grain drying columns or in the metering rolls is not frozen. Frozen grain would prevent the dryer from unloading, which could possibly result in a fire.

Before checking metering rolls, Turn Off Power Supply to dryer and flip Motor Circuit Breaker Switches to OFF position.

If grain is frozen, turn Power Supply ON and start Bottom Burner as described above to thaw grain. Be careful not to operate burner more than (5 to 10) minutes to avoid exposing dry grain to excessive heat and the chance of fire.

Start discharge auger, then place Metering Roll Switch into MANUAL to see if metering rolls turn. Be sure to turn off Metering Roll Switch immediately if rolls do not turn.

Final Shut Down

When finishing a crop or at the end of the season all of the grain in the dryer must be dry before the dryer is completely unloaded.

1. When wet grain level is below sight glass, turn the discharge metering roll switch OFF. See Figure 25.
2. Run the burners until all of the grain is at the desired moisture content (approx. 5 minutes per point of moisture to be removed).
3. When the grain is dry, close the LP Gas supply valve at the tank or close the natural gas supply valve. Operate the burner(s) until the flame goes out. Turn the ignition switch(es) OFF.
4. Close the burner gas main hand valve(s) (handle 90° to the piping).
5. **LP Gas** - Close the liquid line flip valve for each burner (handle down) and the hand valve at the LP Gas inlet hose.
6. Run the fans approximately 20 minutes to cool the grain in the dryer, then turn them off.
7. Turn the discharge auger switch to the ON position and release. Wait (1) minute, then turn the discharge metering roll switch to the MANUAL position to unload dryer. When dryer is empty, turn the discharge metering roll switch to OFF. Make sure discharge

auger is empty, then turn discharge switch to OFF.



CAUTION: Before continuing to the next step, turn off and lock the electric power supply to the dryer. Place all of the red protector switches in the motor control to the OFF position and lock the door.

8. Clean out the unload auger and the grain metering rolls. Each unload auger pan is hinged on the left side and secured on the right side with two overcenter latches. Push the handle on the latches down to open the pans and pull them up overcenter to lock the pans.
9. Clean the fan(s), burner(s) and heat chamber(s).
10. Clean all of the screens. If the dryer is equipped with a heat recovery system, remove and clean the bottom covers.
11. Lubricate all bearings with a hand grease gun. See "Lubrication." Do not over

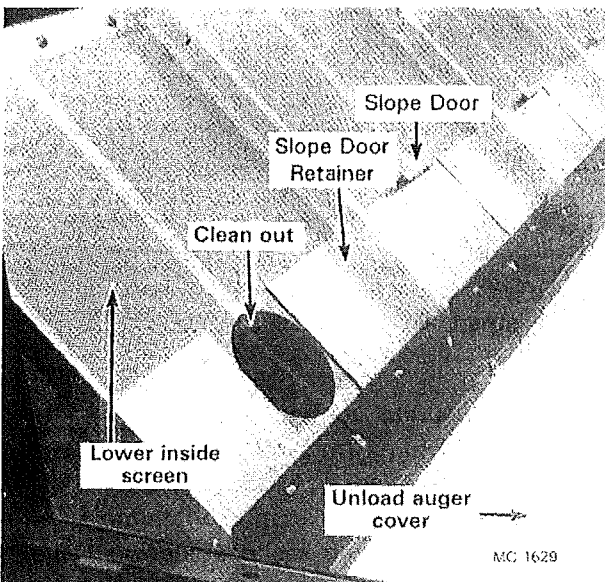

Figure 32

lubricate. Too much grease may damage the bearing seals. Lubricate the SCR drive chain and sprockets with engine oil.

12. Loosen the level auger and unload auger drive belts.

Moisture Monitor and Printer

As soon as electric power is supplied to dryer, the Moisture Monitor and Printer will be activated. The Printer is equipped with an on and off switch to control its operation.

Moisture Monitor Instructions

- A. The Digital Display Meter shows grain moisture constantly and should read approximately 6% when Sensor is in open air (no grain passing over Sensor), see Figure 33.
- B. Push Grain Temperature Button and the display meter will show Temperature of Grain on the sensor, see Figure 33.
- C. Push Calibration Button and the display meter will show the amount added to or subtracted from the displayed moisture (-9.9 to +9.9), see Figure 33.

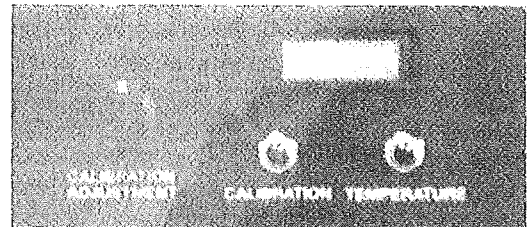

Figure 33

- D. The Moisture Monitor may need to be calibrated to compensate for different grains and sensor configurations. Make sure that the calibration is set at zero before comparing the displayed moisture values with the samples tested with a reliable moisture tester. See Figure 34, Moisture Monitor Sampling Chart, on page 36.

1. If the displayed moisture value is less than from a moisture tester, push the "Display Calibration" and turn the calibration knob to display the actual difference (+ Value).
2. If the displayed moisture value is more than from the moisture tester value, push the "Display Calibration" and turn the calibration knob to display the actual difference with a minus sign (- Value).



CAUTION: Use a safe sampling procedure. Do not sample from a hopper with an unguarded auger. Keep hands, feet and clothing away from rotating parts.

3. The following sampling guidelines are recommended:

- a. Take samples when the displayed moisture values are not changing rapidly.
- b. Observe the moisture display when the sample is taken. Record both the displayed values and tested values for at least six (6) samples and take the average of each.
- c. Take samples from the Grain Sampler located on the left side of the Unload (Discharge) Auger Box, see Figure 30.

Question: Where would you set the moisture offset, +0.3 or 0.6?

Answer: Most would want to set it to +0.3 which would make it match the point of sale's moisture reading.

Moisture Monitor Sampling					
The chart shows grain moisture readings (from a real situation) as they should be taken to obtain a realistic moisture value.					
Time	M-C Monitor		Dole		Elevator
	Temp.	Moisture	Temp.	Corrected Moisture	Moisture
9:33AM	112	14.4%	109	14.7%	
9:36AM	112	14.4%	111	14.4%	
9:38AM	108	16.0%	107	17.5%	
9:40AM	110	14.6%	109	14.7%	
9:43AM	108	15.9%	104	17.3%	
9:50AM	111	14.5%	107	15.0%	
Total		89.8%		93.6%	
Average		15.0%		15.6%	15.3%

Figure 34

Printer

The printer provides a printed record of:

1. Time.
2. Mode.
3. Grain Discharge Moisture.
4. Grain Discharge Temperature.
5. Ambient Temperature from Weather Station.
6. Average Discharge Moisture.
7. Relative Humidity from Weather Station.
8. Calibration (Moisture Offset).
9. Bin # that is being filled with dry grain.

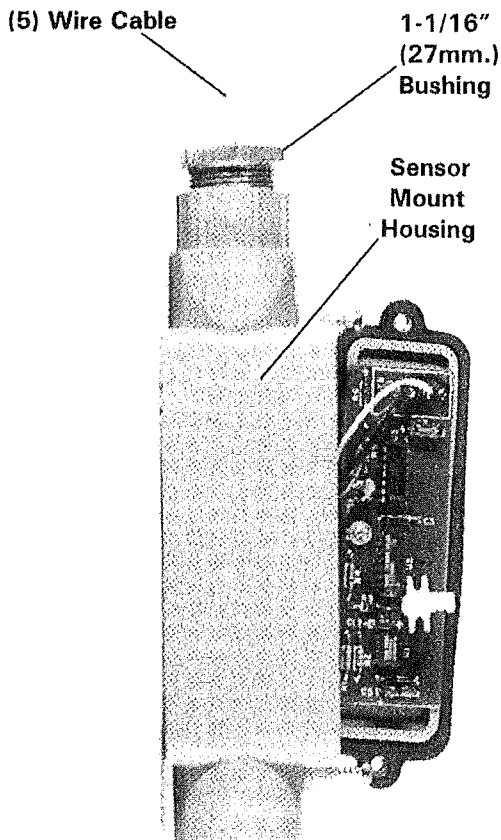

Figure 35 - Weather Sensor

A Weather Sensor is supplied with the Printer, but must be installed by customer when dryer installation is completed, see Figure 35.

The Weather Sensor is not required for the proper operation of the Monitor or Printer.

It is recommended that the Sensor be located about (20) ft. (6.1m.) from the heat and humidity of the dryer.

There are (5) colored wires connected to the Weather Sensor Circuit Board that will have to be connected to the (36) Pin Black Connector (Number Side) that is attached to the top of the Monitor and Printer Interface Board Holder in the Control Cabinet (on dryer or Remote). The (5) wires are:

- White to terminal 11,
- Black to terminal 10,
- Brown to terminal 9,
- Green to terminal 8, and
- Red to terminal 7.

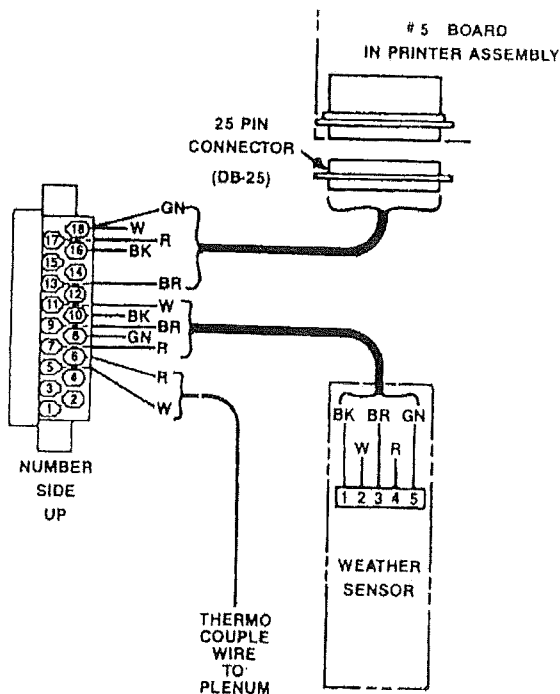

Figure 36

If the dryer is controlled with a Remote Cabinet that is a sufficient distance from the heat and humidity produced by the dryer, the Weather Sensor can be mounted to the outside bottom of the Remote Cabinet.

A 1-3/32" (27.8mm.) diameter hole will have to be drilled in the bottom of the Remote Cabinet.

The special 1-1/16" (27mm.) threaded bushing is then placed into the hole with the thread end to the bottom.

The (5) wire cable from the Sensor Board is pulled up through the bushing and the Mount Housing is secured to the bottom of the cabinet by turning the bushing into the mount housing until tight. Now place the (5) wires listed above into their correct terminals and tighten, see Figure 36.

If the Control Cabinet is mounted to the dryer fan housing, a location away from the dryer is recommended (about 20 ft. (6.1m.) if possible. Once a suitable location is selected, secure the Weather Sensor Mount Housing.

A length of (5) wire cable will probably have to be spliced and soldered to the 8 ft. (2.44m.) cable supplied with the Weather Sensor to reach the distance selected from the dryer. Be sure to allow 36" (92cm.) from the bottom of the remote cabinet to the (36) Pin Black Connector at the top inside of the cabinet. See Figure 36.

The (5) wire cable should be placed into a separate 3/8" (9.5mm.) flexible liquidite conduit or a 1/2" (12.7mm.) metal conduit from Sensor Mount Housing to the bottom of the Control Cabinet. No high voltage (115V) wires are to be placed in same conduit as the (5) low voltage Sensor wires.

PRINTER DEFINITIONS

Printer Module and Printout

A "COLD START" OCCURS WHEN BATTERIES ARE NOT INSTALLED OR ARE WEAK AND NEED REPLACING (APPROXIMATELY EVERY 2 YEARS).

THIS DATA NEEDS TO BE ENTERED FOR OPERATION.

IF ENTRY IS NOT ACCEPTED THE QUESTION IS REPEATED.

ACCEPTABLE NUMBER INPUTS ARE:

MM = MONTH 01 THRU 12
 DD = DAY 01 THRU 31
 YY = YEAR 00 THRU 99
 HH = HOUR 01 THRU 12
 MM = MINUTE 01 THRU 60

PRINTS OUT YOUR ENTERED INFORMATION.

AUTOMATICALLY SET AT FIVE MINUTES. CAN BE SET FROM TWO MINUTES THRU 30 MINUTES.

AUTOMATICALLY SET AT "1", CAN BE NUMBERED UP TO 999.

```

COLD START - CHECK BATTERIES
ENTER THE DATE MMDDYY
DAY? - SUN=1 M=2 T=3 W=4 T=5 F=6 SAT=7
ENTER THE TIME HHMM (12 HR FORMAT)
ENTER 0 FOR AM OR 1 FOR PM
DATE THURSDAY 08-17-89 TIME 08:36A
ENTER 0 TO CHANGE OR # TO ACCEPT
CURRENT INTERVAL IS 5 MINUTES
ENTER 2-DIGITS OR # TO ACCEPT
CURRENT BIN IS # 1
ENTER 3 DIGIT NUMBER OR # TO ACCEPT
  
```

PRINTER DEFINITIONS (continued)

MENU IS PRINTED WHEN ANY KEY IS PUSHED.

DATA ENTERED AT COLD START. BATTERY BACKUP, EVEN WITH POWER LOSS.

ENTER IF OTHER GRAIN IS RUN:

- "1" - CORN
- "2" - MILO
- "3" - RICE
- "4" - WHEAT
- "5" - SOYBEANS
- "6" - SUNFLOWER
- "7" - OTHER

```

GRAIN TYPE? - CORN=1 MILO=2 RICE=3
WHEAT=4 SOYBEAN=5 SUNFLOWER=6 OTHER=7

DATE THURSDAY 08-17-89 TIME 08:54A
1 TO BEGIN PERIODIC READOUT
2 TO CHANGE PRINT INTERVAL--NOW 5 MIN.
3 TO AVERAGE---BEGAN 08-17-89 AT 08:36A
4 TO CHANGE BIN NUMBER--NOW 1
5 TO CORRECT DATE/TIME
6 TO CHANGE GRAIN TYPE--NOW CORN
    
```

FROM WEATHER STATION INPUT AT TIME OF PRINTING. READS "0" WHEN NOT HOOKED UP.

HEADER ALWAYS PRINTED AFTER MENU, EVERY TWO HOURS OF RUNNING TIME, MOISTURE LIMIT CHANGE, AND MOISTURE OFFSET CHANGE.

ANY TIME YOU WANT TO GO TO THE MENU, HIT ANY KEY ON THE KEYBOARD. THIS WILL INTERRUPT THE PRINTING AND PRINT THE MENU.

NOTE: AFTER YOU ARE FINISHED USING THE MENU, PRESS "1" TO AGAIN BEGIN THE READOUT. THIS WILL NOT AFFECT THE AVERAGING, UNLESS YOU HAD RESET THE AVERAGING.

```

R.H. 67% CALIBRATION 0.0 PLENUM 00

HIT ANY KEY FOR MENU
      MACH  GRAIN  GRAIN  AMB  CORN
      TIME  MODE  MOIST  TEMP  AVE
      ----  ---  ----  ---  ---
09:09A  MON   15.0   77   76  14.8
09:10A  MON   15.2   77   76  14.8
09:10A  MON   14.6   77   76  14.8
    
```

Sample Printer Readout

TIME:
SET AT COLD START.
RESET BY MENU INPUT.

MODE:

MON = MONITOR

```

03-11-98  SETPOINT 0.0  BIN # 6
R.H. 67% CALIBRATION 0.0 PLENUM 00
HIT ANY KEY FOR MENU
      MACH  GRAIN  GRAIN  AMB  CORN
      TIME  MODE  MOIST  TEMP  AVE
      ----  ---  ----  ---  ---
09:09A  MON   15.0   77   76  14.8
09:10A  MON   15.2   77   76  14.8
09:10A  MON   14.6   77   76  14.8
    
```

NOT USED

MOISTURE OFFSET:
DIRECT READING FROM
THE CONTROL PANEL
CALIBRATION.

NOT USED

AMBIENT TEMPERATURE:
FROM WEATHER STATION
INPUT AT TIME OF
READING.

AVERAGE MOISTURE:
GIVES A RUNNING
AVERAGE OF ALL
READINGS SINCE START
OF AVERAGING TIME.
STARTS WHEN UNIT IS
STARTED AFTER "COLD
START" OR WHEN RESET
FROM MENU.
NOTE: TO FIND WHEN
LAST AVERAGE BEGAN,
PUSH ANY KEY AND READ
FROM LINE 3 OF MENU.
TO RESTART PRINTING
PUSH "1".

GRAIN MOISTURE: ACTUAL
GRAIN MOISTURE AT THE
SENSOR - TEMPERATURE
COMPENSATED

GRAIN TEMPERATURE: ACTUAL
GRAIN TEMPERATURE AT THE
SENSOR.

NOTE: Replace batteries every year, use two "AA" alkaline batteries. Turn off power to the unit, replace the batteries, then turn on power and reprogram if "Cold Start" notation is printed.

PRINTER ASSEMBLY

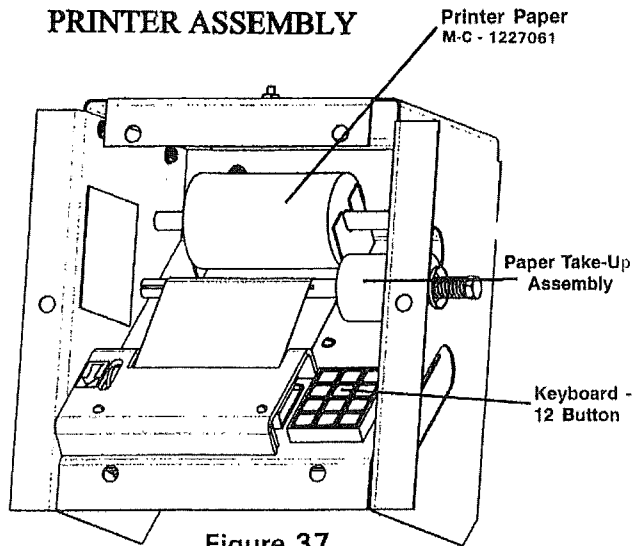

Figure 37

DIP SWITCH SETTING ON MONITOR BOARD

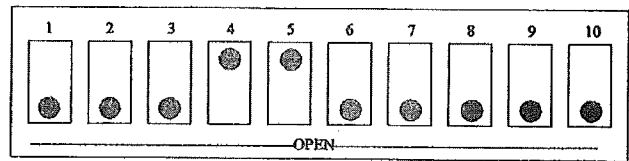

Figure 38

TROUBLE SHOOTING GUIDE

PROBLEM	PROBABLE CAUSE	SOLUTION
Blowing control fuses	<ol style="list-style-type: none"> 1. Check for loose or shorted leads 2. Any component that is bad can cause this - check by isolating one component at a time. 	<ol style="list-style-type: none"> 1. Isolate and correct. 2. Replace bad component
Printer spaces several lines but nothing is printed.	<ol style="list-style-type: none"> 1. Paper installed with the wrong side up or the wrong type of paper. 2. Print head is unplugged or bad. 	<ol style="list-style-type: none"> 1. Turn over the paper or install correct paper (MS0306)
Printer spaces one line, nothing more.	<ol style="list-style-type: none"> 1. Computer control card not seated correctly or bad. 2. 5 conductor cable loose or installed in error. 	<ol style="list-style-type: none"> 1. Insert the computer card or replace card. 2. Refer to the decal for correct wiring at the computer jack. Insert the 25 pin jack at the printer.
Printer does not space, no night light and the paper take-up motor not working.	<ol style="list-style-type: none"> 1. No DC power or no AC power or not hooked up. 	<ol style="list-style-type: none"> 1. If 5V DC is missing, replace the power supply or repair loose or broken power leads (red and green) or (white and violet).
Printer doesn't space but has night light.	<ol style="list-style-type: none"> 1. Printer motor not plugged in. 	<ol style="list-style-type: none"> 1. Plug in the flat, gray cable on the printer and check if broken.
Prints characters that are unintelligible.	<ol style="list-style-type: none"> 1. Computer not working. 	<ol style="list-style-type: none"> 1. Power down and retry.
Top part of the characters are missing.	<ol style="list-style-type: none"> 1. Plastic guard too close. 	<ol style="list-style-type: none"> 1. Raise the plastic shield.
Part of each character is missing.	<ol style="list-style-type: none"> 1. Head cable loose or print head bad. 	<ol style="list-style-type: none"> 1. Reseat the flat brown cable or replace the printer.
Paper take-up not rolling up the paper.	<ol style="list-style-type: none"> 1. Loss of power or bad motor or aluminum shaft binding against the motor. 	<ol style="list-style-type: none"> 1. The orange and orange/white wire loose or broken. Retighten or replace the motor assembly or adjust the aluminum shaft by loosening the allen screw.

NOTES

MAINTENANCE



CAUTION: Do not allow children or bystanders near the dryer while it is being adjusted and/or serviced.

Lubrication



CAUTION: To prevent accidental starting of the motors during lubrication, turn off the electric power supply to the dryer. Place all the red protector switches to the OFF position and lock motor control cabinet door.

NOTE: Use a hand grease gun to lubricate bearings. Use a good grade of bearing grease and do not over lubricate. Too much grease may damage the bearing seals. Avoid getting grease on any of the belts.

Change the oil in the SCR drive gear box after the first two weeks of operation. Use Mobil SHC 634 oil or equivalent. Gear box capacity is $\frac{3}{4}$ pint. Also change the oil at the start of each drying season.

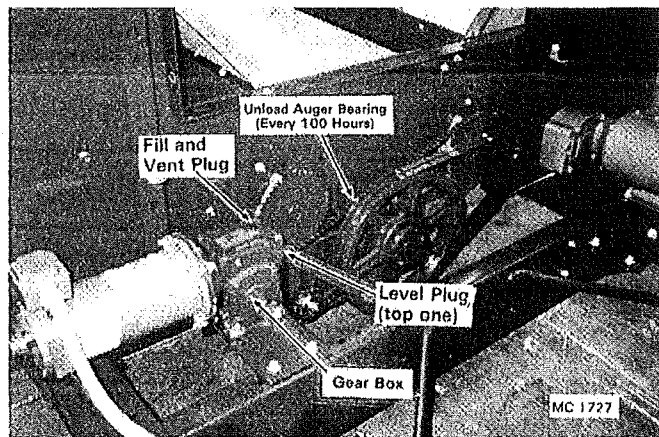

Figure 39

Every 100 Hours

1. Lubricate the unloading auger front bearing. See Figure 39.
2. All other bearings used on the dryer are prelubricated and require no further lubrication.

Periodically

1. Remove the oil level plug (top one) on the end of the SCR drive gear box. See Figure 39. The oil level should be even with the bottom of the hole. If not, remove the vent plug on top of the gear box and add Mobil SHC 634 oil or equivalent until it just runs out. Install the level and vent plug.
2. Oil SCR drive sprockets and chain with engine oil. Be careful not to get oil on the belts.

Screens and Heat Recovery System

NOTE: Be sure to keep the inside screens and heat chambers as clean as possible to reduce the possibility of fire. Also, a clean dryer works better than a dirty one.

1. Check the exterior screens periodically and clean as necessary.
2. Clean the inside screens and heat chambers every 8 to 10 hours.
3. If the dryer is equipped with a heat recovery system, remove and clean the bottom covers.

NOTE: Under some drying conditions, the inside screens and heat recovery bottom covers may have to be cleaned more often.

Belt Adjustment

General

1. After approximately 24 hours of operation the belts will seat themselves in the pulley grooves and the tension may have to be readjusted. If the belts squeal when the motor starts they are not tight enough.
2. Never apply belt dressing as this will damage the belt and cause early belt failure.

Discharge Auger

Loosen the unload auger motor mounting locknuts. Turn locknut on the "J" bolt to adjust tension.

Level Auger

Adjust the belt tension by loosening the locknuts and raising the motor mount plate evenly with the four adjusting nuts, then tighten the locknuts, see Figure 40.

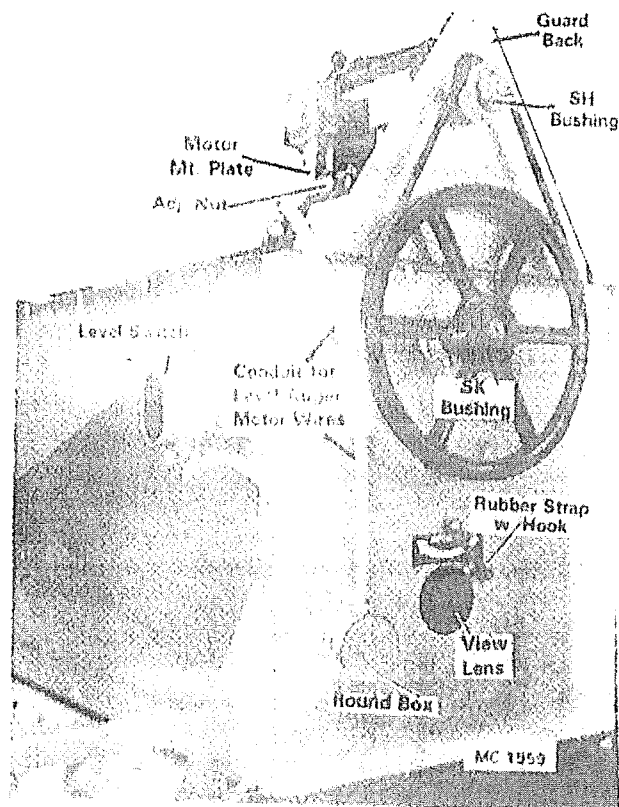

Figure 40

Pre-Season Check

All of the following tests and adjustments can be made when the dryer is empty. The air pressure switch, modulating valve and vaporizer coil (LP Gas) adjustments can only be made when the dryer is full of grain. These adjustments are covered under "Initial Start-Up Instructions" on page 22.



CAUTION: The gas and electric power supply to the dryer must be off when performing steps 1 through 7. Place all the red protector switches into the OFF position.

General

1. Lubricate all bearings, chains and sprockets. Check the oil level in the SCR drive gear box. Refer to "Lubrication" on page 40.

2. Check and adjust the unload and level auger belts. Refer to "Belt Adjustment."
3. Tighten all electrical connections in the dryer control and motor control cabinets. Check the ground connection in the cabinets to be sure they are clean and tight. Also, check the ground connection from the dryer ground lug in the motor control cabinet to the grounding rod.
4. Clean out the unload auger and grain metering rolls. Each unload auger pan is hinged on the left side and secured on the right side with two overcenter latches. Push the handle on the latches down to open the pans and pull them up overcenter to lock the pans.
5. Clean all of the screens, fan(s), burner(s) and heat chamber(s). Remove and clean heat recovery system bottom covers (if equipped).
6. Remove the air pressure switch(es) and clean the tube and filter. See Figure 41 . Be sure the vent hole in the bottom of the air pressure switch is open, see Figure 42 .
7. **LP Gas** - Remove the plug at the end of each strainer. See Figure 43. Remove and clean the screen in each strainer. Check flexible LP hoses for signs of fatigue. Replace as necessary.

Level Auger and Discharge System

1. Place all of the switches on the control panel to the OFF position. Flip all of the circuit breakers in the bottom cabinet ON. Turn the electric power supply to the dryer ON.
2. Turn the Power On Switch to the ON position and release. The Power On Light will light.
3. Check level auger. Turn the Level Auger Switch to the MANUAL position. The level auger will start immediately.
4. Push the spring loaded Discharge Auger Switch to ON and release. The discharge auger will start.
5. Turn the discharge metering roll switch to the MANUAL position. The SCR drive motor will start. Turn the SCR speed control to change speed.

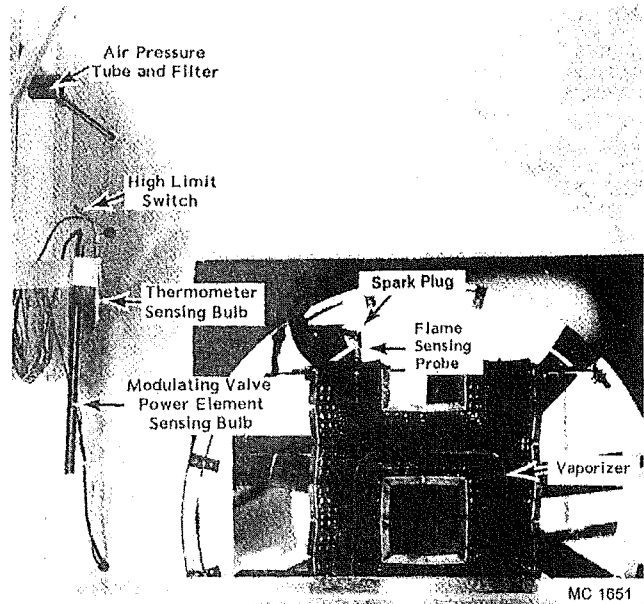

Figure 41 - 6 MBTU Burner - 320 & 520

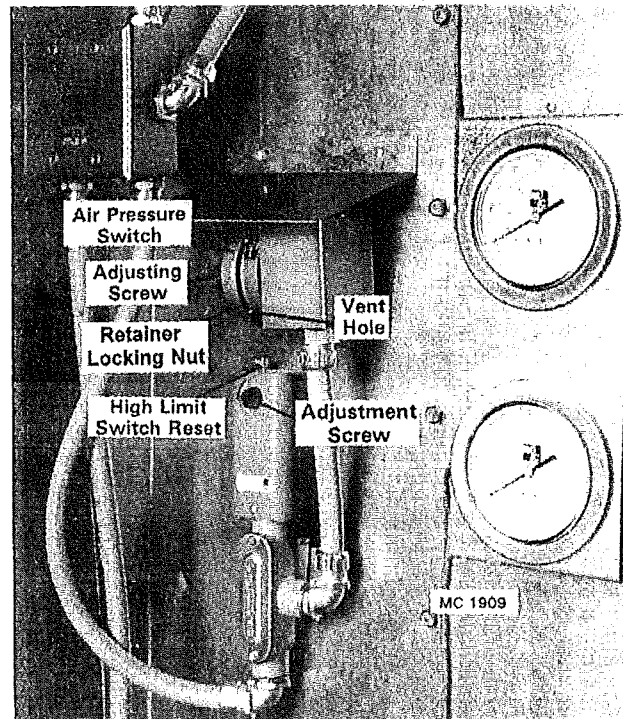

Figure 42

6. With a voltmeter, check the SCR motor maximum speed by moving the Speed Control Dial to ten (10) and read DC voltage between the (2) terminals on rear of Discharge Meter. If motor maximum DC voltage is not correct (70 volts), see "SCR Board Trim Pot Adjustment Procedure" on page 48.

NOTE: To perform the balance of the discharge system check, the outside air temperature must be above 50°F.

7. Set the SCR speed control to mid-range and lock in place. Turn the moisture control dial to balance the lights.
8. Turn the discharge metering roll switch to AUTOMATIC. The SCR drive motor will run at the speed selected in step 7.
9. Turn the moisture control balance dial up until decrease light goes on. The SCR motor speed will decrease.
10. Turn the moisture control balance dial down until the increase light goes on. The SCR motor speed will increase.

Fans and Burners

1. Turn off the electric power supply to the dryer. Turn all of the switches on the control panel to the OFF position.
2. Close the burner gas manifold hand valve for each burner (handle 90° to piping), see Figure 43.
3. To test burner(s) without grain in dryer, place a jumper wire with alligator clips between terminal (4) of the fan motor Start Button and the Air Pressure Light terminal with the yellow wire of the burner being tested. Both the switch and light are located on the Control Cabinet Inside Door. This jumper wire will by-pass the Air Pressure Switch.
4. **LP Gas** - Open the supply tank valve, the main shut off hand valve after the 1" (25.4mm.) inlet hose, and open (lift up) the ½" (12.7mm.) liquid line flip valve on each burner, see Figure 43.

Natural Gas - Open the supply valve.

 **CAUTION:** This is only a temporary procedure for checking the burner. When drying grain, **NEVER** operate the dryer with the air pressure switches disconnected or by-passed. This safety air pressure switch is for your protection and the protection of the dryer.

5. Turn on the electric power supply to the dryer and turn the Power On Switch to ON. The Power On Light and High Limit Light(s) will be on. If any high limit light is not on, push the reset button on that high limit switch, see Figure 42.
6. Start the bottom burner fan, the air pressure light will be ON. When the fan comes up to speed, open the burner gas manifold hand valve ¼ of the way. Be sure Burner Switch is in the LOW position. Turn the ignition switch ON. After a (15) second delay the gas valve light will be ON and the burner will light.

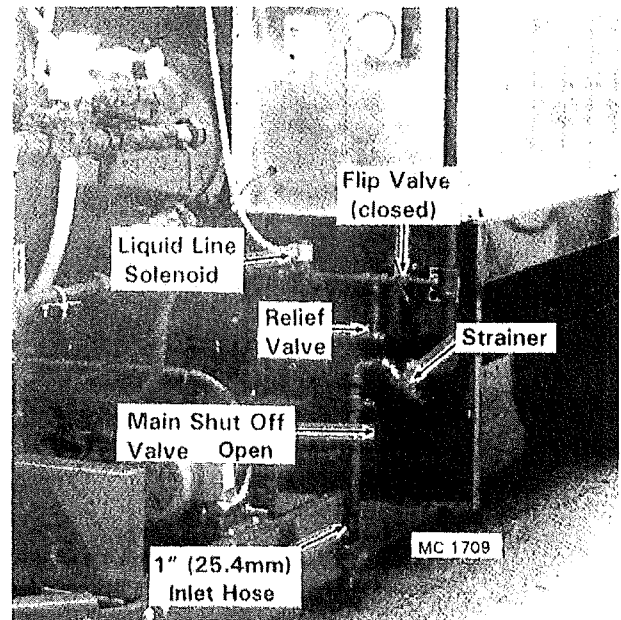

Figure 43

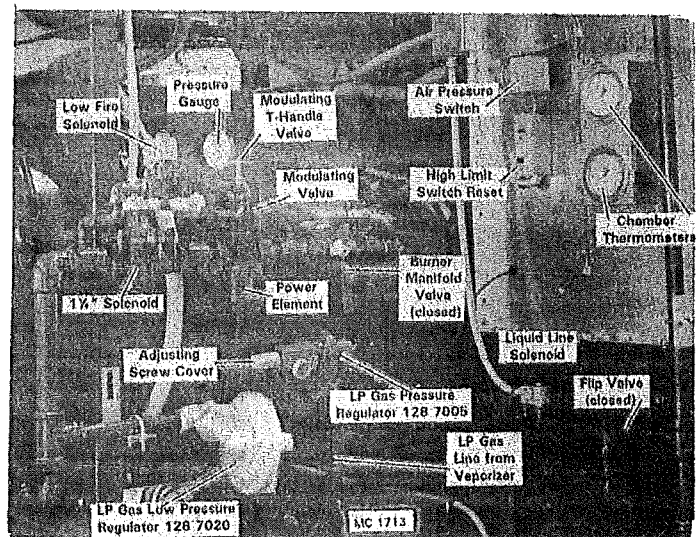

Figure 44

7. If after several attempts for ignition the burner fails to light, turn off fan, electric power supply to dryer, fan motor circuit breaker, and close the burner gas manifold hand valve (handle 90° to piping). Turn all control panel switches to the OFF position. Check for broken continuity or loose wires, corroded connections, and incorrect wire connections. Be sure to check continuity of the large high tension wire.



CAUTION: Before checking ignition wires, be sure to ground high tension coil (E1 terminal) on ignition board to eliminate any charge that may remain in coil.

Check ignition switch with voltmeter.

8. Now check 115V power to Ignition Board. Connect a voltmeter between terminal L1 and L2 on ignition board. Turn on electric power supply to dryer. Be sure bottom fan #1 circuit breaker is still off and jumper wire is still in place between terminal #4 of the fan #1 Start Button and the terminal of the Air Pressure Light with the yellow wire. Now turn the Power On Switch to ON and release. Push the fan start button and air pressure light will light. Turn the Ignition Switch ON and after the (15) second delay the voltmeter should read 115V. If not, place ignition switch in OFF position and Turn Off Electric Power to dryer. Now check again for loose or broken wire from ignition switch to ignition board.

If there is 115V between terminal L1 and L2, check for 115V at terminal V1 on the ignition board. Turn Off Electric Power to dryer and turn Ignition Switch to the OFF position. Connect a voltmeter between terminal V1 and V2 on the ignition board. Turn on electric power to dryer and turn Power On Switch to ON. Turn Ignition Switch to ON position. After (15) second delay the voltmeter should read 115V. If not, the ignition board is defective and must be replaced.

NOTE: The voltmeter will show a reading during the "trial ignition" period only (5 seconds). To check again, turn the ignition switch OFF then ON. The (5) second "trial ignition" period starts after the (15) second delay.

9. If there is 115V at terminal V1, check to be sure that solenoid valves are operating. Two (2) persons will be required to make this test of the solenoid valves; (1) to operate the ignition switch and the other to be at the solenoid valves as there is only (5) seconds to check the solenoid valve.

Liquid propane burners have (1) ½" (12.7mm.) Liquid Line solenoid valve, (1) ¾" (19mm.) Low Fire solenoid valve, and (1) 1¼" (31.75mm.) High Fire solenoid valve, all located on the left side of the dryer fan orifice(s) when viewed from the rear of the dryer. See Figures 43, and 44.

Natural gas burners have (2) 1¼" (31.75mm.) solenoid valves and (1) ¾" (19mm.) Low Fire solenoid valve. To check solenoid valves, remove red cap from the top of solenoid valves, hold a screwdriver near coil and turn ignition switch to ON. If coil is working a magnetic attraction will be felt after (15) second delay. You will also hear a click when the coil energizes.

On liquid propane burners check the ½" (12.7mm.) liquid line valve first, then the ¾" (19mm.) Low Fire vapor and then the 1¼" (31.75mm.) High Fire vapor solenoid valves.

If no click is heard or there is no magnetic attraction of the screwdriver, the solenoid coil will have to be replaced. If the solenoid coils are being energized, assume for the moment that gas is being allowed to enter the vaporizer and burner.

10. Now check spark plug for spark. Turn off electric power to dryer. Be sure burner gas manifold hand valve is still closed, fan #1 motor circuit breaker is in OFF position, jumper wire between terminal #4 of fan #1 Start Button and the terminal of the Air Pressure Light with the yellow wire is still connected, and the Ignition Switch is in the OFF position.

Turn on electric power to the dryer. Turn Power On Switch to ON and release. Push lower fan #1 Start Button and Air Pressure Light will light. Turn Ignition Switch to ON and after the (15) second purge delay, observe Spark Plug through the View Lens in the rear door of heat chamber during the (5) second "trial ignition" period. In some cases the spark can also be heard.

If there is no spark, turn Ignition Switch OFF then ON for another "trial ignition" period. If there is still no spark, the Ignition Board will have to be replaced. Turn Ignition Switch and Power On Switch to OFF. Turn off electric power to dryer.

Once ignition board has been replaced, retest burner #1 as described under Fans & Burners steps (1) thru (6) page 43.

11. After lower burner #1 ignites, allow burner to operate for about (2) minutes, then close ½" (12.7mm.) liquid line flip valve if burner is LP or the 1¼" (31.75mm.) burner manifold hand valve if natural gas. Operate fan #1 until burner #1 goes out. Turn Ignition Switch and Power On Switch to OFF. Now turn off electrical power to dryer.

 **CAUTION:** Be sure to remove the jumper wire with the alligator clips between #4 terminal of fan #1 Start Button and the terminal of Air Pressure Light #1 that has the yellow control wire.

12. Check upper burner #2 using the same procedure that was used for burner #1 outlined in steps (1) thru (6) on page 43. After burner #2 has been operating for (2) minutes, close the LP supply tank valve if burner is LP or natural gas supply valve if burner is natural gas. Operate fan #2 until burner goes out. Then close the 1" (25.4mm.) gas main shut off valve, the ½" (12.7mm.) flip valve, and the 1¼" (31.75mm.) burner #2 manifold hand valve if LP or just the 1¼" (31.75mm.) burner #2 manifold hand valve if natural gas. Turn Ignition Switch and Power On Switch to OFF. Don't forget to close the 1¼" (31.75mm.) burner #1 manifold hand valve if burner is LP. Turn off electrical power to dryer.

 **CAUTION:** Be sure to remove the jumper wire with the alligator clips between #4 terminal of fan #2 Start Button and the terminal of Air Pressure Light #2 that has the yellow control wire.

Lock control and magnetic starter cabinets.

13. When testing a dryer with a single burner, follow steps (1) thru (6) on page 43. Operate burner for (2) minutes then close supply tank

valve if burner is LP or the natural gas supply valve if natural gas. Operate fan until burner goes out. Then close 1" (25.4mm.) gas main shut off valve, the ½" (12.7mm.) flip valve, and the 1¼" (31.75mm.) burner manifold hand valve if LP or just the 1¼" (31.75mm.) burner manifold hand valve if natural gas. Turn Ignition Switch and Power On Switch to OFF. Turn off electric power supply to dryer.

 **CAUTION:** Be sure to remove the jumper wire with the alligator clips between #4 terminal of fan Start Button and the terminal of Air Pressure Light that has the yellow control wire.

Lock control and motor control cabinets.

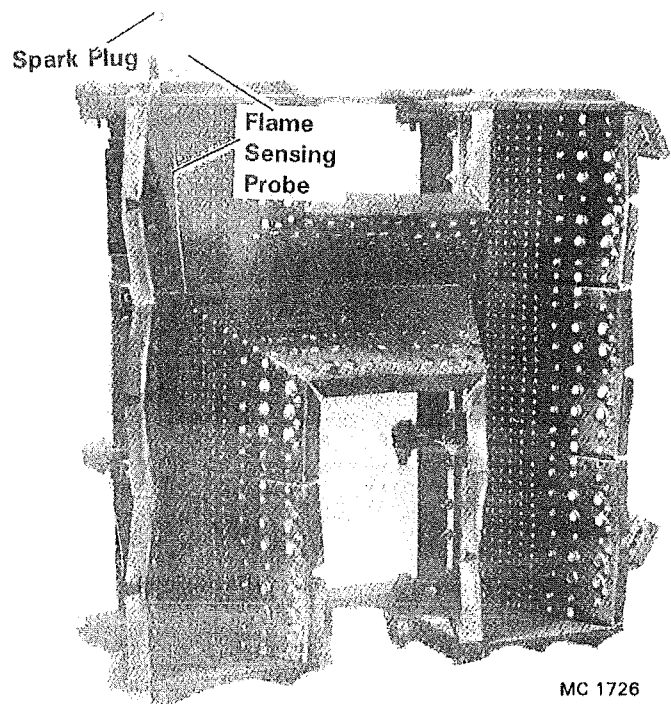

Figure 45 - 4 MBTU Burner - 720/820 Bottom

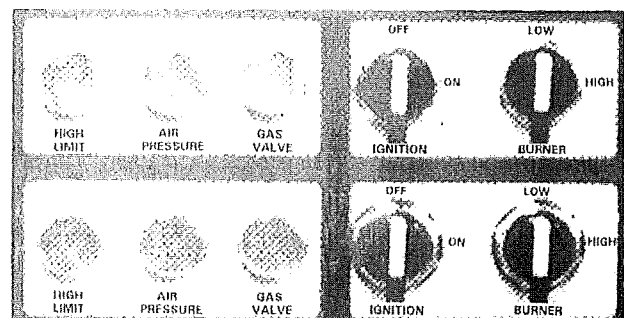

Figure 46

Direct Spark Ignition System

Operation

The direct spark ignition system consists of an electronic ignition board, an ignition spark plug and flame sensing probe. See Figure 46A. For ignition to occur, the dryer must be running and the High Limit and Air Pressure lights on the control panel must be on.

The dryer is wired so that the current flow from the control cabinet goes to the High Limit Switch, Fan Start and Stop Buttons, Fan Protector Fault, Air Pressure Switch, Ignition Switch, and the (15) Second Delay that is built into the Ignition Board. These safety features prevent ignition if the heat chamber temperature is too high or there is insufficient air flow, and allows for a (15) second air purge of any unburned gas that may remain in the heat chamber after burner shutdown.

When the ignition switch is turned to ON, the ignition board is energized (after the (15) second built-in delay) and generates a high voltage spark between the tips of the spark plug and opens the

gas solenoid valves at the same time. The gas valve light on the control panel will be on.

The spark plug provides the spark for ignition and the flame sensing probe senses the presence of the flame. See Figure 45. A small 108 volt current passes from the flame sensing probe to the flame which conducts the current completing the electrical circuit. If the flame is not present, the circuit will be broken and the ignition system will "lock out."

The ignition board is electronically timed so that when the ignition switch is turned ON, the spark plug will spark and the gas solenoid valves will be held open for a "trial ignition" period of (7) seconds -- after the (15) second purge delay.

When ignition occurs and a flame is present, the ignition board flame monitoring system will continue to operate but the spark will shut off. If there is a flame failure, the ignition board will "lock out" (after a (7) second trial for ignition) closing the gas solenoid valves. The gas valve indicator light on the control panel will be out. Turn the ignition switch to OFF, then to ON for another "trial for ignition." See Figure 46.

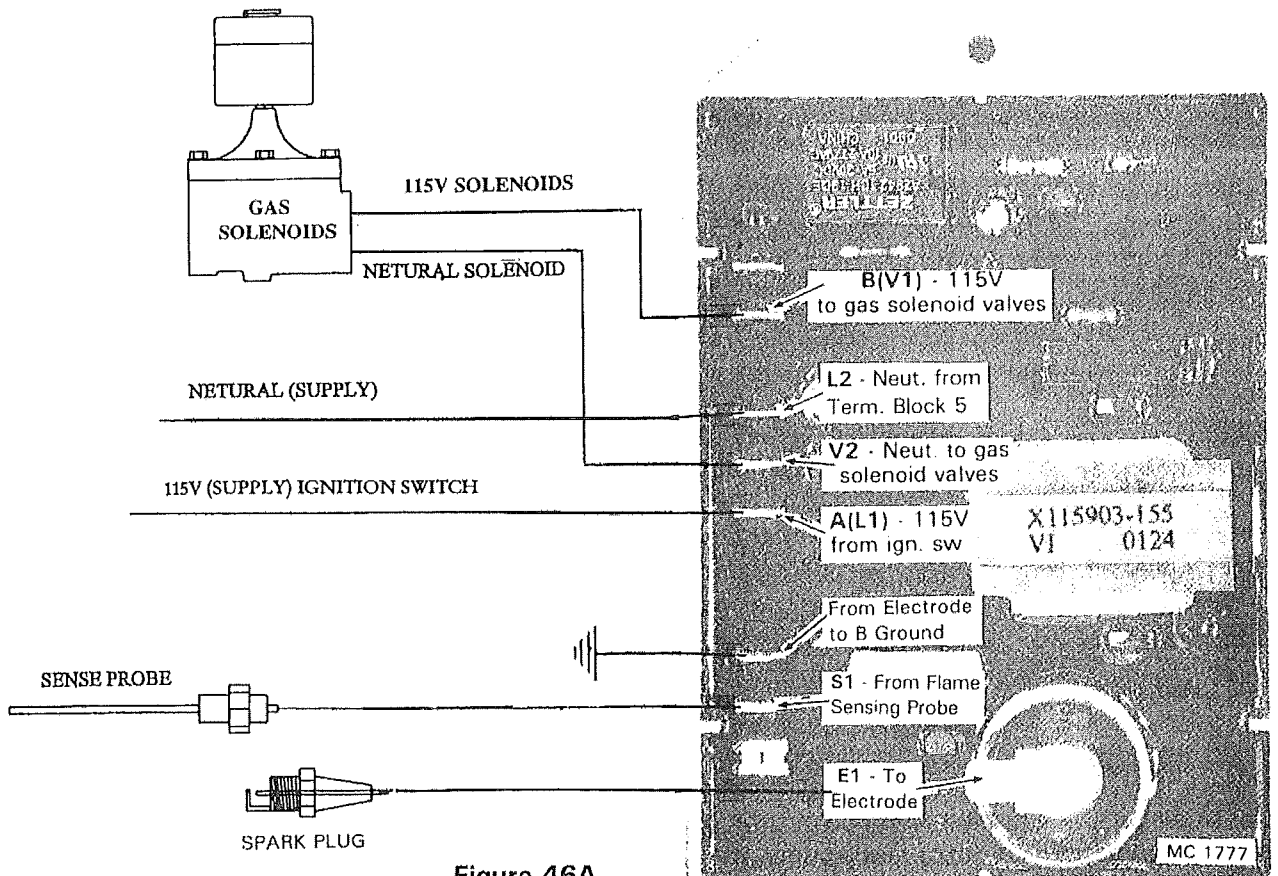

Figure 46A

Discharge System

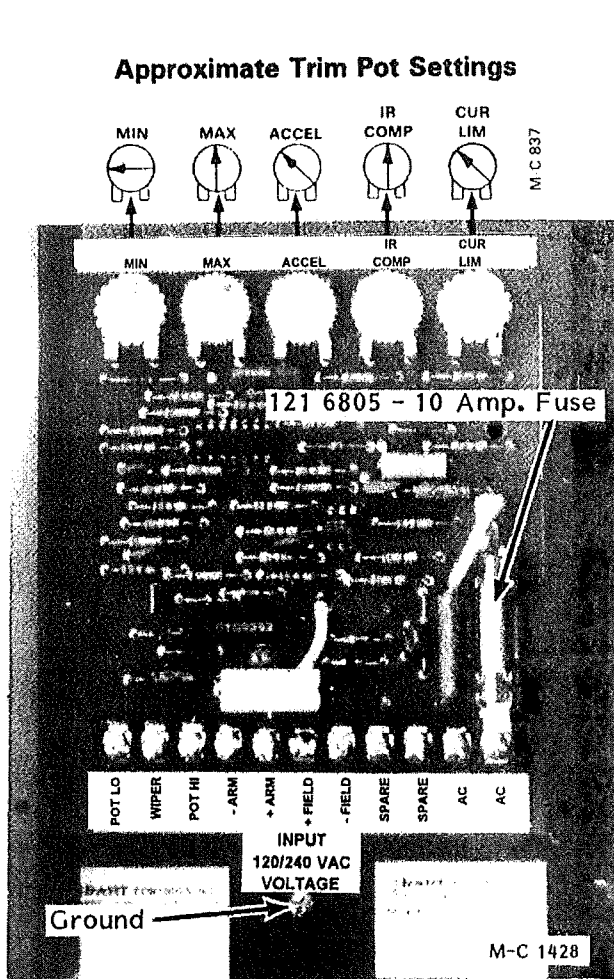

Figure 47 - SCR Drive Control Board

Description

The metering rolls are driven by a 1/3HP variable speed permanent magnet DC motor and reduction gear box. The RPM range of the metering rolls is 1/2 to 10.

The speed of the motor is directly proportional to the amount of DC voltage supplied to it. When voltage increases speed increases and when voltage decreases speed decreases.

The SCR control board converts incoming AC current to DC current and controls the amount of DC voltage going to the motor. The SCR speed control regulates the amount of DC voltage the SCR control board supplies to the motor.

When the discharge metering roll switch is in the AUTOMATIC position, the moisture control controls the SCR board.

SCR Board Terminal Strip Connections

- POT LO - NOT USED
- WIPER - Connects to (+) of Moisture Control Board.
- POT HI - NOT USED
- + ARM - Connects to motor armature wires 0-90 volts DC. MUST NOT BE SWITCHED OR BROKEN WHILE POWER IS ON or serious damage to SCR board may result.
- ARM - Connects to motor armature wires. Reverse + and - motor leads to reverse motor rotation. MUST NOT BE SWITCHED OR BROKEN WHILE POWER IS ON or serious damage to SCR board may result.
- + FIELD - NOT USED
- FIELD - Connects to (-) of Moisture Control Board.
- SPARE - NOT USED
- SPARE - NOT USED
- AC LINE - Connect hot wire 115 volt AC.
- AC LINE - Connect neutral wire (white).

SCR Board Trim Pot Adjustment Procedure

NOTE: Figure 47 shows approximate trim pot settings. Follow adjustment procedure below for final calibration.

Trim Pot	Function	Adjustment
MIN.	(Starting with S/N 56052) The Dart SCR Board minimum speed trim pot is non-functional. The minimum speed is now fixed by the M-C Moisture Control Board for both the auto and manual mode.	None.
MAX.	Sets Maximum Motor Speed when Speed Control is set at maximum (10) 100% rotation CW. CW rotation of MAX trim pot increases maximum motor speed.	<ol style="list-style-type: none"> 1. TURN DRIVE POWER OFF! 2. Connect DC Voltmeter + to + ARM, - to - ARM. 3. Set meter voltage range: (90 VDC). 4. Turn power on. Set SPEED control at 100% (10). 5. Adjust MAX pot to rated motor armature voltage as shown on meter (70 volts DC). <p>NOTE: A tachometer or strobe may be used in lieu of a meter. Follow above steps, except adjust MAX pot to rated motor speed (1750 RPM).</p>
ACCEL	Allows Adjustment of Acceleration	<ol style="list-style-type: none"> 1. CW rotation increases time of acceleration (.5 to 8 seconds).
IR COMP	Calibrates speed regulation – % speed change from no load to full load at adjusted speed.	<ol style="list-style-type: none"> 1. Set SPEED control at 50% (5). 2. Turn IR COMP pot CW until motor begins to hunt. 3. Turn IR COMP CCW until hunting stops. 4. Set IR COMP pot 1/3 of the span between where motor hunting stopped and fully CCW position. <p>NOTE: For more precise calibration, a tachometer or strobe may be substituted for the above.</p>
CUR. LIM	Limits DC motor armature current (torque) to prevent damage to the motor or SCR board. The current limit is set for the rated motor current. CW rotation of this trim pot increases the armature current (or torque produced).	<ol style="list-style-type: none"> 1. TURN DRIVE POWER OFF! 2. Connect a DC Ammeter between A1 on motor and + ARM on SCR board. This is in series with motor. 3. Turn power on. 4. Set SPEED control at 50% (5). 5. Apply friction braking to the motor shaft until motor stalls (zero RPM). 6. While motor is stalled, set current at 125% of rated motor armature current on the nameplate 4.4 amps (3.5 amps x 125%) by adjusting the CUR LIM pot. Remove ammeter after calibration.

Troubleshooting Discharge System



CAUTION: To avoid electrical shock that could result in personal injury or possible death, always use properly insulated tools when checking electrical components and circuits. **NEVER** check circuit continuity by shorting terminals with a screwdriver or other metal devices.

SCR Drive Motor Does Not Run (Metering roll switch in MANUAL position)

Problem	Possible Cause	Remedy
A. No 115 volt AC input between "AC Line" terminals on SCR board.	<ol style="list-style-type: none"> 1. Discharge auger not running. 2. SCR 8 amp. circuit breaker tripped. 3. Defective or dirty discharge relay. 4. Loose wire or defective switch(es). 	<ol style="list-style-type: none"> 1. Start discharge auger. 2. Reset. 3. Clean or replace if necessary. 4. Trace power flow. See discharge circuit schematic at back of this manual.
B. No DC voltage output between "Arm + and Arm -" terminals on SCR board.	<ol style="list-style-type: none"> 1. SCR board 10 amp. fuse blown. 2. Minimum motor speed set incorrectly. 3. Defective speed control. 4. Defective SCR board. 	<ol style="list-style-type: none"> 1. Replace. 2. See "Trim Pot Adjustment" on page 48. 3. Replace. 4. Replace.
C. Have 115 volt AC input between "AC Line" terminals and output of 6 to 70 volts DC between "Arm + and Arm -" terminals.	<ol style="list-style-type: none"> 1. Overload condition. 2. Current limit set incorrectly. 3. Maximum motor speed set incorrectly. 4. Worn or improperly seated motor brushes. 5. Moisture or dirt accumulation in motor. 6. Defective motor. 	<ol style="list-style-type: none"> 1. Check metering rolls and gear box for binding. 2. See "Trim Pot Adjustment" on page 48. 3. See "Trim Pot Adjustment" on page 48. 4. Replace or adjust. 5. Disassemble and dry or clean. 6. Replace.

SCR Drive Motor Does Not Run (Metering roll switch in AUTOMATIC position)

Note: Operation of the moisture control is explained on page 30.

Problem	Possible Cause	Remedy
A. Motor operates normally when metering roll switch is in the MANUAL position, but not in the AUTOMATIC position.	<ol style="list-style-type: none"> 1. Moisture control set too high. 2. Grain temperature not high enough to allow discharge. 	<ol style="list-style-type: none"> 1. Adjust set point. 2. Allow time.

Problem	Possible Cause	Remedy
	3. Wet grain slug covering temperature probe.	3. Operate in MANUAL for several minutes to clear area.
	4. Loose wire or defective switch(es).	4. Trace power flow. See discharge circuit schematic at back of this manual.
	5. Defective Moisture Control System.	5. Replace.

SCR Drive Motor Runs Erratically (Metering roll switch in MANUAL position)

Problem	Possible Cause	Remedy
A. Motor speed fluctuates.	1. Loose connection from speed control potentiometer. 2. Defective speed control potentiometer. 3. Motor is at current limit. 4. Too much "IR" compensation.	1. Trace power flow. See discharge circuit schematic at back of this manual. 2. Replace potentiometer. 3. See "Trim Pot Adjustment" on page 48. 4. See "Trim Pot Adjustment" on page 48.
B. Speed control does not regulate motor speed.	1. Loose connection from speed control potentiometer. 2. Defective speed control potentiometer. 3. Minimum and maximum speed set incorrectly. 4. Defective SCR board.	1. Trace power flow. See discharge circuit schematic at back of this manual. 2. Replace. 3. See "Trim Pot Adjustment" on page 48. 4. Replace.
C. Motor runs backwards.	1. Motor leads reversed.	1. Switch leads.
D. Repeated blowing of SCR board 10 amp. fuse.	1. Low input voltage between "AC Line" terminals on SCR board. 2. Current limit set too high. 3. Motor shorted. 4. Worn motor brushes. 5. Defective motor bearings. 6. Defective SCR board.	1. Check - should be above 110 volts AC. 2. See "Trim Pot Adjustment" on page 48. 3. Replace or repair. Check for moisture in motor. 4. Replace. 5. Replace. 6. Replace.

Continued on next page

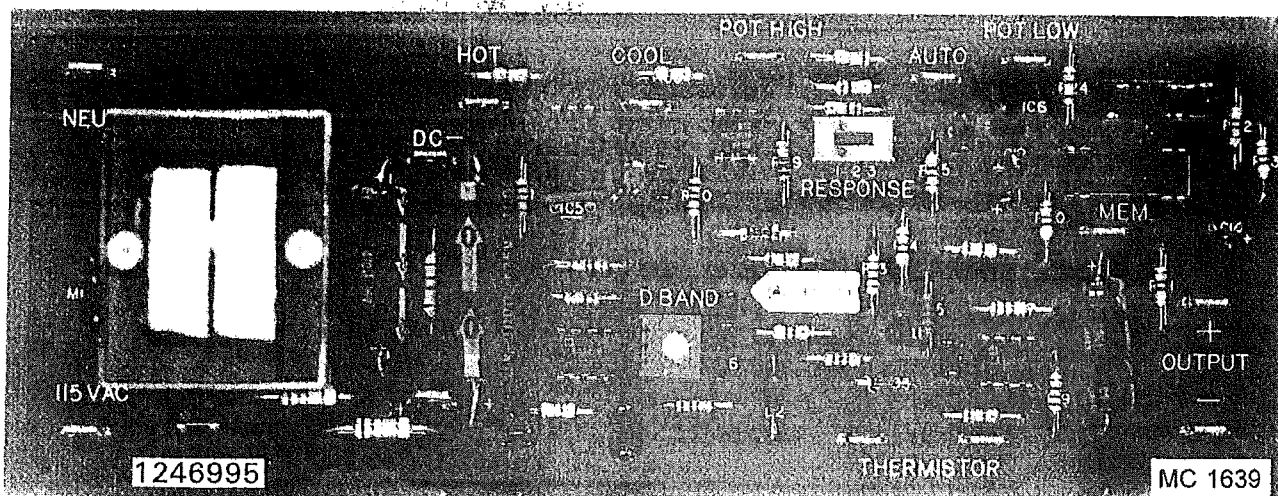

M-C MOISTURE CONTROL SYSTEM

Problem	Corrective Action																								
A. Increase and decrease lights will not go off when calibrating Moisture Control System.	1. Adjust the deadband trip pot on Moisture Control System board (R-7) until both lights stay off when turning moisture control dial two spaces on the scale.																								
B. Metering rolls will not run.	1. Discharge auger starter interlock bad. 2. Discharge auger not started. 3. Moisture Control System amp fuse is blown. 4. Moisture Control System board inoperative. Check output voltage at (+) and (-) terminals on Moisture Control System board. Voltage should be approximately 3 to 11 volts DC depending on the SCR speed control potentiometer setting in manual or moisture control setting in automatic. If no voltage, consult factory.																								
C. Moisture Control System does not control grain moisture.	1. Moisture Control System MANUAL OFF-AUTO switch not in AUTO position. 2. Bad thermistor. Check response with ohmmeter. <table border="1" data-bbox="656 1423 1263 1793"> <thead> <tr> <th><u>Thermistor Temp.</u></th> <th><u>Thermistor Resistance</u></th> </tr> </thead> <tbody> <tr><td>30°F</td><td>29,000 OHMS</td></tr> <tr><td>40°F</td><td>23,000 "</td></tr> <tr><td>50°F</td><td>18,000 "</td></tr> <tr><td>60°F</td><td>14,500 "</td></tr> <tr><td>70°F</td><td>11,000 "</td></tr> <tr><td>110°F</td><td>5,200 "</td></tr> <tr><td>120°F</td><td>4,200 "</td></tr> <tr><td>130°F</td><td>3,600 "</td></tr> <tr><td>140°F</td><td>3,000 "</td></tr> <tr><td>150°F</td><td>2,500 "</td></tr> <tr><td>160°F</td><td>2,100 "</td></tr> </tbody> </table> 3. Bad Moisture Control System board. 4. Bad moisture control potentiometer. Check potentiometer with ohmmeter. 5. Burner temperature not holding steady.	<u>Thermistor Temp.</u>	<u>Thermistor Resistance</u>	30°F	29,000 OHMS	40°F	23,000 "	50°F	18,000 "	60°F	14,500 "	70°F	11,000 "	110°F	5,200 "	120°F	4,200 "	130°F	3,600 "	140°F	3,000 "	150°F	2,500 "	160°F	2,100 "
<u>Thermistor Temp.</u>	<u>Thermistor Resistance</u>																								
30°F	29,000 OHMS																								
40°F	23,000 "																								
50°F	18,000 "																								
60°F	14,500 "																								
70°F	11,000 "																								
110°F	5,200 "																								
120°F	4,200 "																								
130°F	3,600 "																								
140°F	3,000 "																								
150°F	2,500 "																								
160°F	2,100 "																								

Electrical and Gas Piping Entrance

TOP VIEW OF DRYER

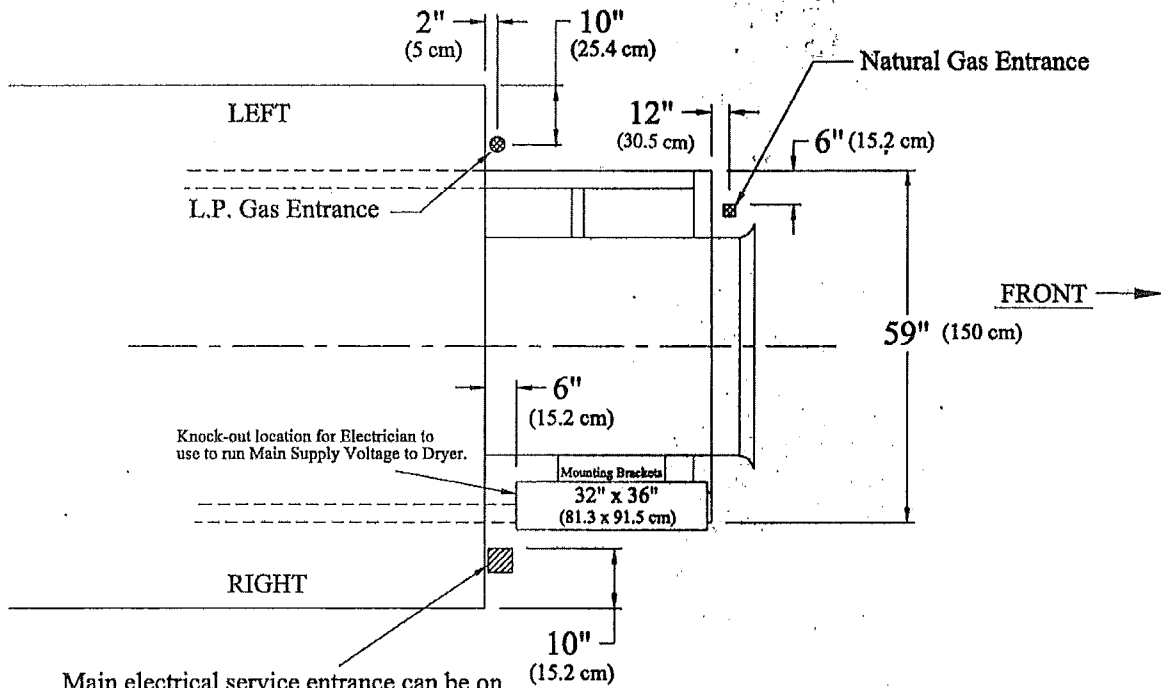

Main electrical service entrance can be on side area near top of high voltage cabinet. Knock-outs to be provided by the electrician at the site.

Dryer Base Dimensions

All Dimensions Are In Inches (Centimeters)

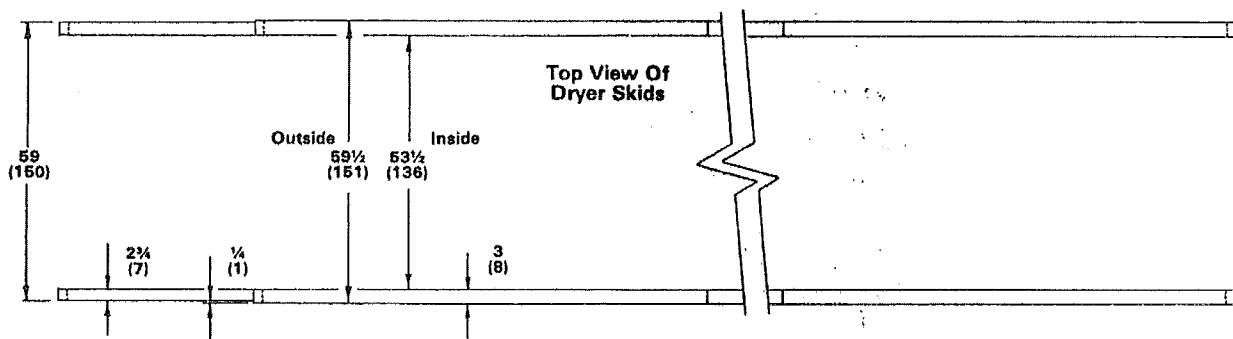

M-C 808

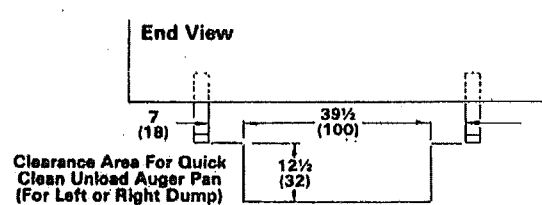

Model CF320 Dryer Dimension Chart

All Dimensions Are In Inches (Centimeters)

NOTE: The Grain Receiving Hopper Tube Ring is 10" (25.4cm.) I.D. - 12.5" (31.75cm.) O.D.
 The Grain Unload Auger Discharge Ring is 10" (25.4cm.) I.D. - 12.5" (31.75cm.) O.D.

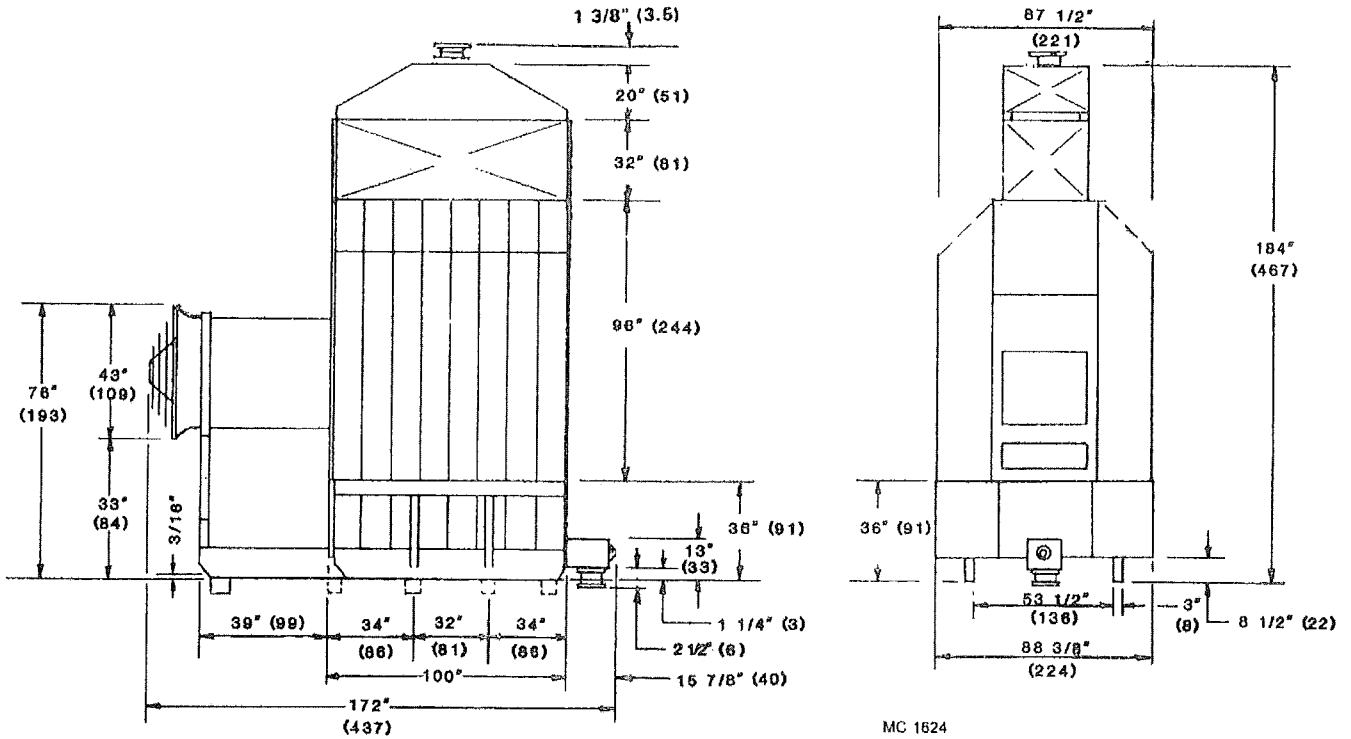

Model CF320 Stand Kit Placement

- 1280329 - 24" (61cm) Front Stand Weldment
- 1280326 - 24" Dryer Stand Weldment
- 1280330 - 36" (91.5cm) Front Stand Weldment
- 1280324 - 36" Dryer Stand Weldment

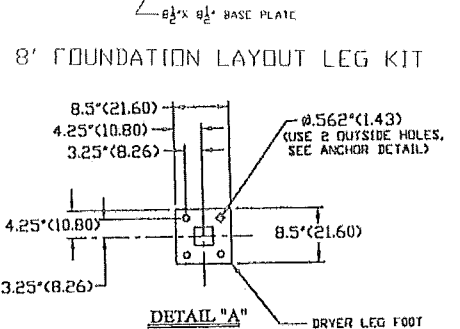
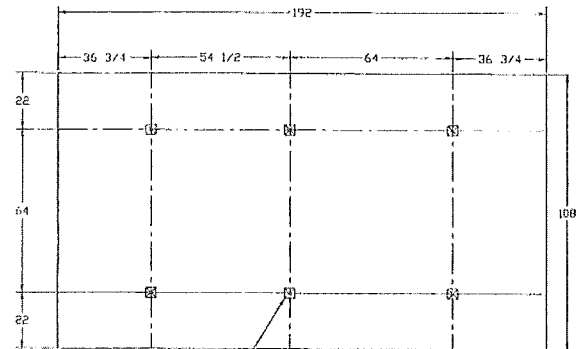
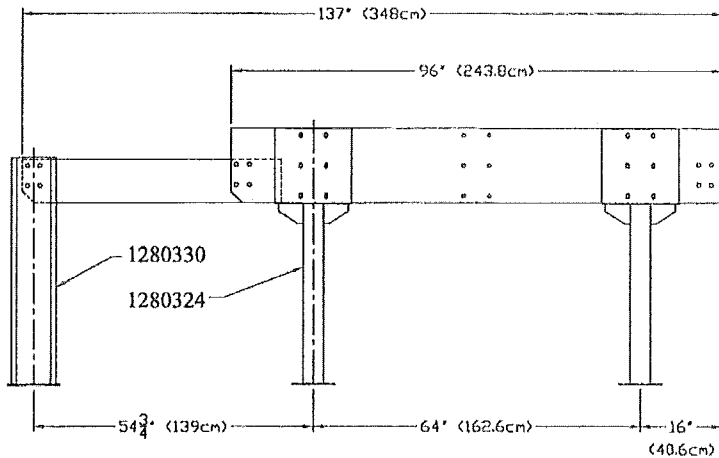

Model CF 410/420 Dryer Dimension Chart

All Dimensions Are In Inches (Centimeters)

NOTE: The Grain Receiving Hopper Tube Ring is 10" (25.4cm.) I.D. - 12.5" (31.75cm.) O.D.
 The Grain Unload Auger Discharge Ring is 10" (25.4cm.) I.D. - 12.5" (31.75cm.) O.D.

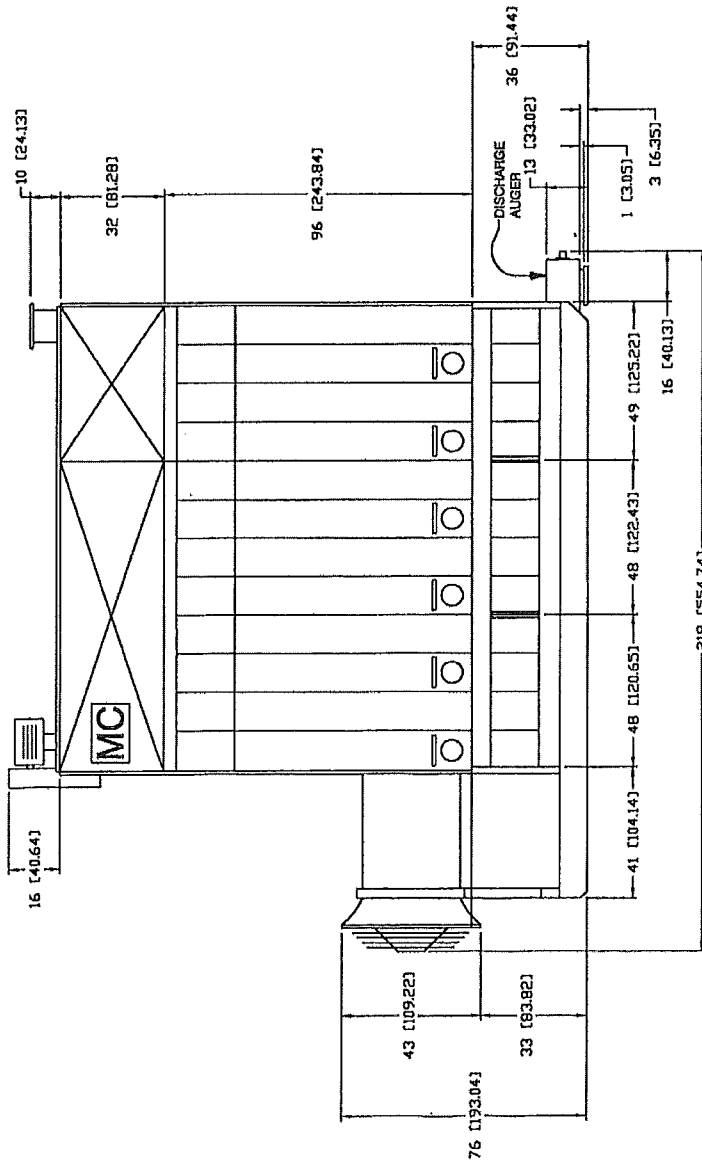
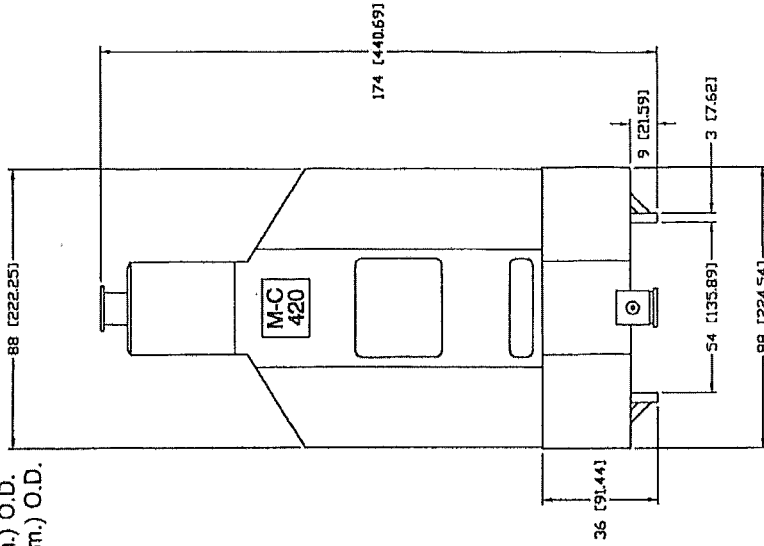

REAR VIEW

SIDE VIEW

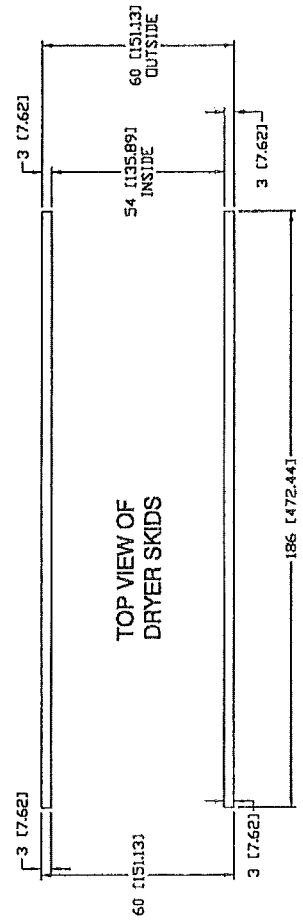

Model CF520 Dryer Dimension Chart

All Dimensions Are In Inches (Centimeters)

NOTE: The Grain Receiving Hopper Tube Ring is 10" (25.4cm.) I.D. - 12.5" (31.75cm.) O.D.
 The Grain Unload Auger Discharge Ring is 10" (25.4cm.) I.D. - 12.5" (31.75cm.) O.D.

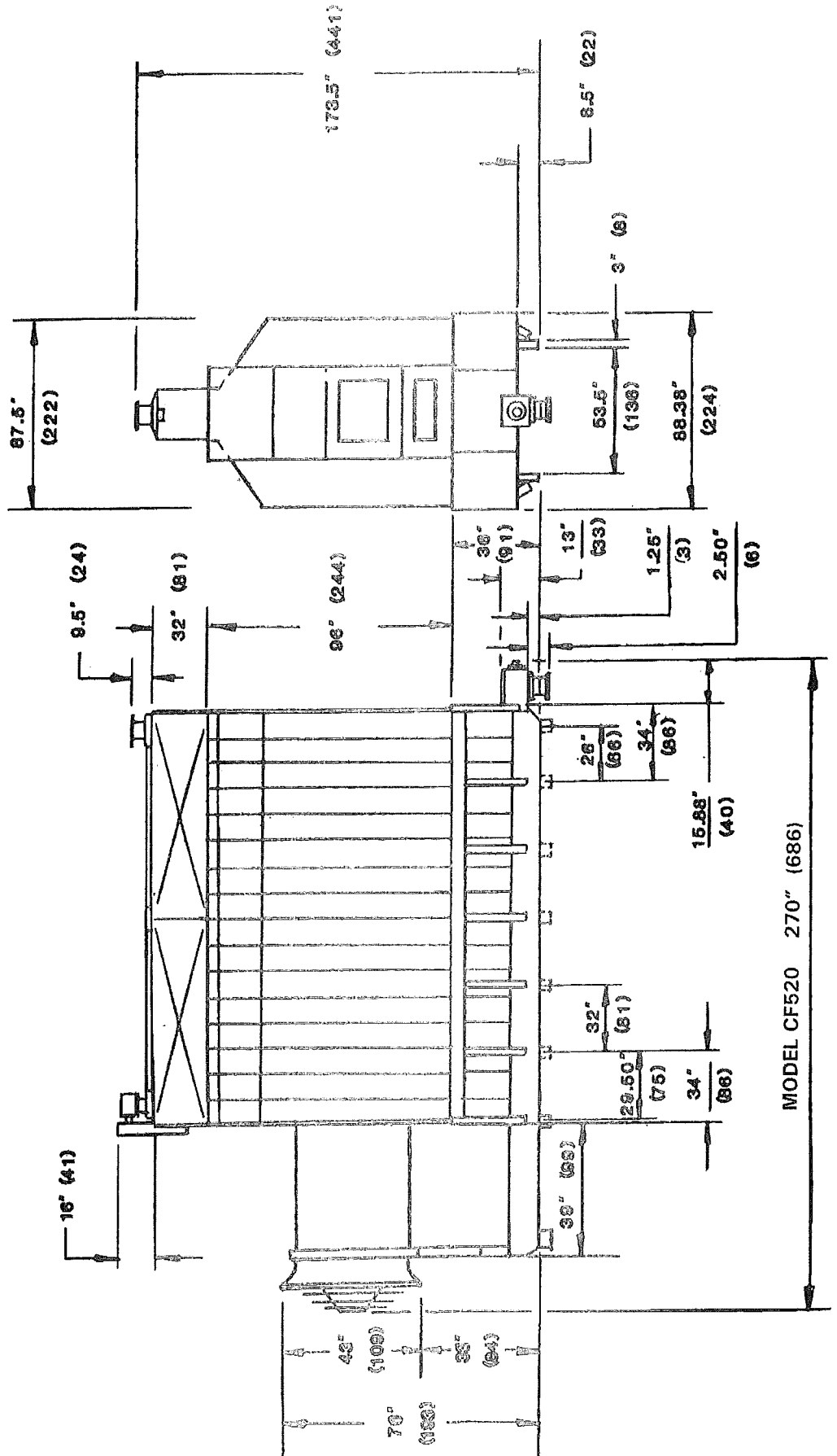

Model CF620 Dryer Dimension Chart

All Dimensions Are In Inches (Centimeters)

NOTE: The Grain Receiving Hopper Tube Ring is 10" (25.4cm.) I.D. - 12.5" (31.75cm.) O.D.
 The Grain Unload Auger Discharge Ring is 10" (25.4cm.) I.D. - 12.5" (31.75cm.) O.D.

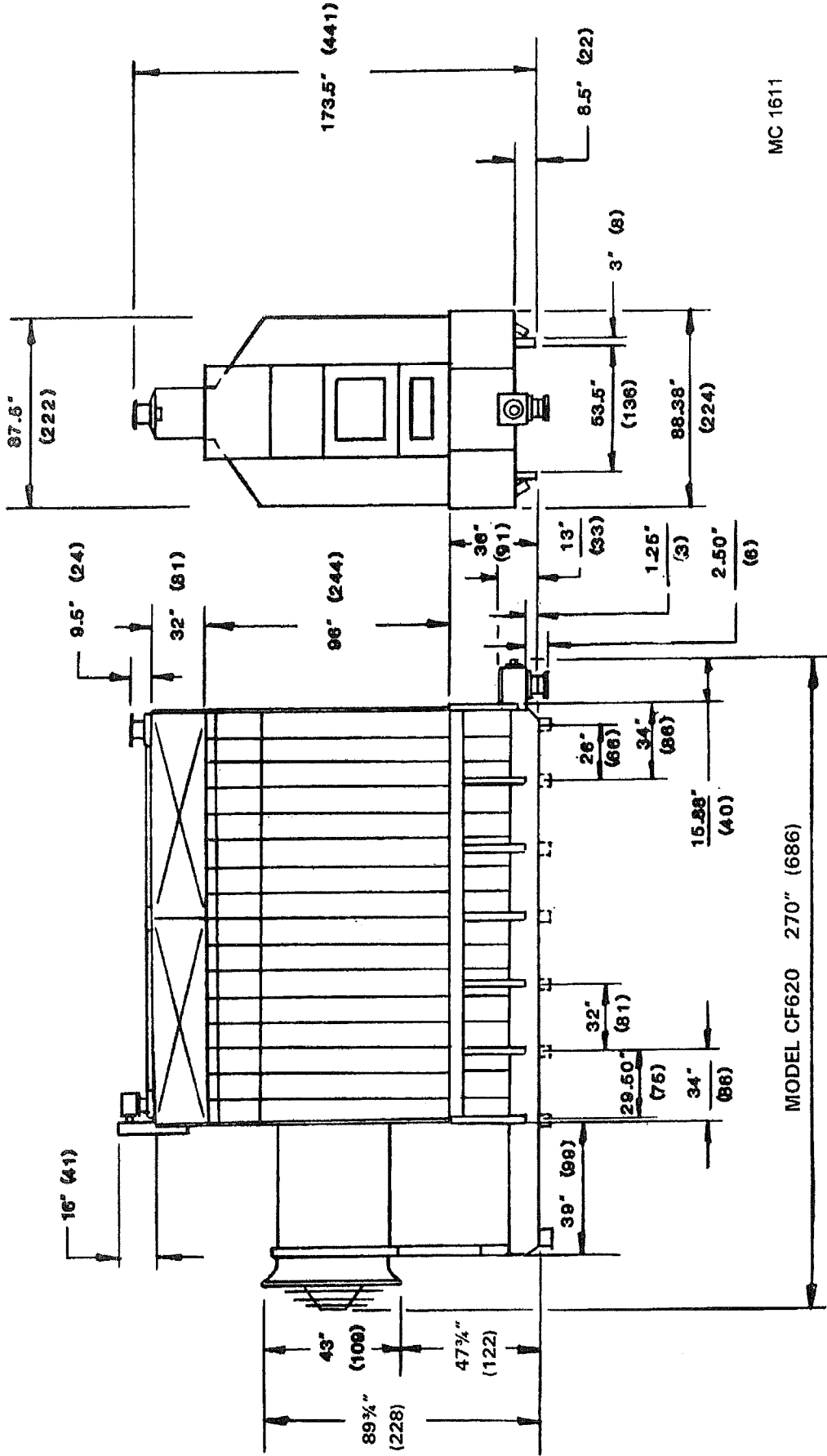

MC 1611

Model CF720 & CF820 Dryer Dimension Chart

All Dimensions Are In Inches (Centimeters)

NOTE: The Grain Receiving Hopper Tube Ring is 10" (25.4cm.) I.D. - 12.5" (31.75cm.) O.D.
 The Grain Unload Auger Discharge Ring is 10" (25.4cm.) I.D. - 12.5" (31.75cm.) O.D.

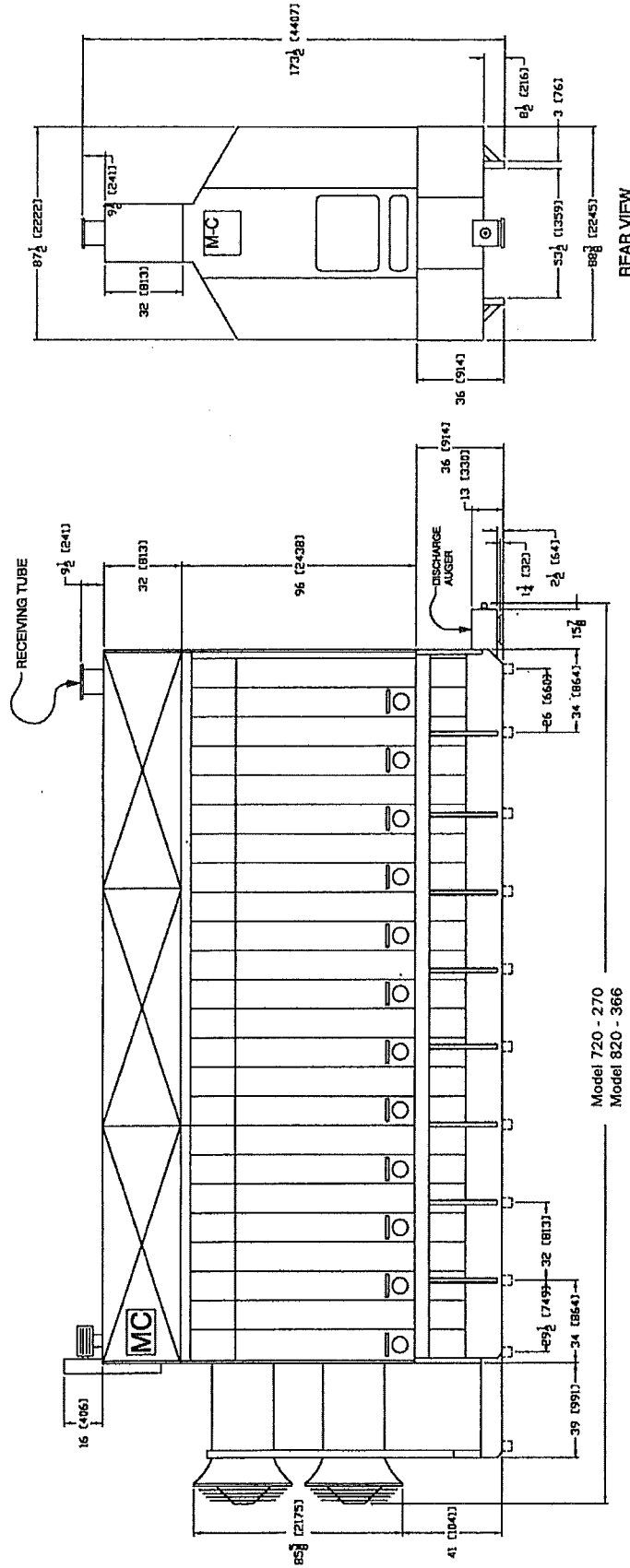

Model 720 - 270
 Model 820 - 366

SIDE VIEW

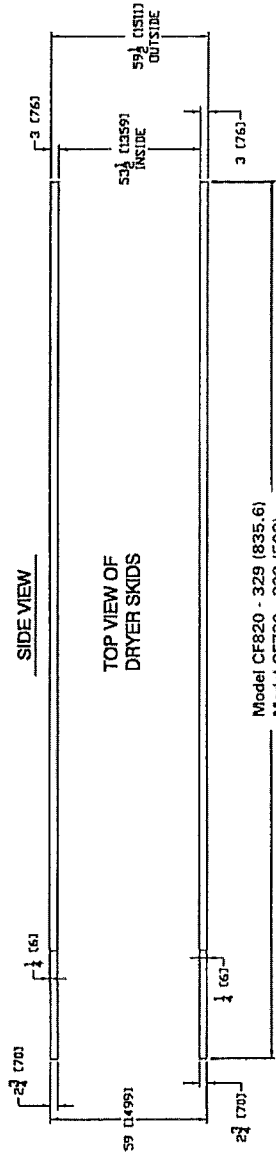

**TOP VIEW OF
 DRYER SKIDS**

Model CF820 - 329 (835.6)
 Model CF720 - 233 (592)

GENERAL NOTES

GENERAL

1. REFER TO DESIGN LOADS LISTED BELOW.
2. CONTRACTORS TO ASSUME FULL RESPONSIBILITY FOR:
 - a. COMPLIANCE WITH THE CONTRACT DOCUMENTS.
 - b. DIMENSIONS TO BE CONFIRMED AND CORRELATED ON THE JOB SITE AND BETWEEN INDIVIDUAL DRAWINGS OR SET OF DRAWINGS.
 - c. FABRICATION PROCESSES AND CONSTRUCTION TECHNIQUES (INCLUDING EXCAVATION, SHORING, SCAFFOLDING, BRACING, ERECTION, FORMWORK, ETC.)
 - d. COORDINATION OF THE VARIOUS TRADES.
 - e. SAFE CONDITIONS ON THE JOB SITE.
3. UNLESS OTHERWISE NOTED, ALL DETAILS, SECTIONS, AND NOTES ON THE DRAWINGS ARE INTENDED TO BE TYPICAL FOR SIMILAR SITUATIONS ELSEWHERE.

FOUNDATIONS

1. FOOTINGS ARE DESIGNED FOR A MINIMUM SOIL BEARING CAPACITY OF 3,000 PSF.
2. ALL FOUNDATIONS SHALL BE CARRIED DOWN TO DEPTHS SHOWN ON THE DRAWINGS, OR DEEPER, IF NECESSARY TO REACH UNDISTURBED SOIL OF DESIGN CAPACITY.
3. APPROVED FILL MATERIAL IN LOCATIONS WHERE ENGINEERED FILL IS REQUIRED TO OBTAIN PROPER FOUNDATION BEARING CONDITIONS SHALL BE PLACED IN LAYERS NOT EXCEEDING 9" IN LOOSE THICKNESS AND COMPACTED TO A MINIMUM OF 95% OF THE MAXIMUM DENSITY OBTAINED IN ACCORDANCE WITH ASTM SPECIFICATION D1557, MODIFIED PROCTOR METHOD, LATEST EDITION.
4. BENEATH SILO AREA SUBGRADE PREPARATION SHALL INCLUDE THE REMOVAL OF ALL UNSUITABLE SURFACE SOILS INCLUDING SOFT CLAYS, HIGHLY ORGANIC TOPSOIL, ROOT MATTER, DEBRIS AND OTHER DELETERIOUS MATERIALS.
5. IF FILL MATERIAL IS REQUIRED, THE ZONE OF COMPACTED FILL SHALL EXTEND BEYOND THE EDGES OF THE FOOTING A DISTANCE OF ONE FOOT FOR EACH FOOT OF THICKNESS COMPACTED FILL BELOW THE FOOTINGS.

CONCRETE

1. CONCRETE WORK SHALL CONFORM TO:
 - a. ACI 318-89, R92 STANDARD BUILDING CODE REQUIREMENTS FOR REINFORCED CONCRETE.
 - b. ACI 301, SPECIFICATION FOR STRUCTURAL CONCRETE IN BUILDINGS.
2. ULTIMATE COMPRESSIVE STRENGTH OF PORTLAND CONCRETE, STANDARD WEIGHT, AT 28 DAYS, SHALL BE 3,000 PSI, AIR ENTRAINED (0% +/- 1%)
3. CONCRETE CONTRACTOR SHALL NOT POUR ANY CONCRETE IN ADVERSE WEATHER CONDITIONS OR WHEN SUCH ARE FORECAST FOR THE TIME PERIOD FOLLOWING THE POUR UNLESS PROPER CURING AND PROTECTION IS PROVIDED CONTINUOUSLY UNTIL CONCRETE DEVELOPS ITS DESIGN STRENGTH.
4. CONCRETE CONTRACTOR SHALL SUPERVISE ALL TRADES REGARDING PIPING, ELECTRICAL CONDUIT, FIXTURE INSERTS, ANCHORS, ETC., PASSING THRU CONCRETE. BARS SHALL NOT BE CUT OR DISPLACED UNLESS ABSOLUTELY NECESSARY, AND THEN ONLY BY CONCRETE CONTRACTOR. MATCHING BARS EQUAL TO CUT BARS SHALL BE ADDED WITH PROPER LAPS AND EMBEDMENTS. CLEAR DISTANCE BETWEEN SLEEVES SHALL BE MINIMUM OF 8".

5. NO ALUMINUM OF ANY TYPE SHALL BE ALLOWED IN THE CONCRETE WORK UNLESS COATED TO PREVENT ALUMINUM-CONCRETE REACTION. THIS INCLUDES PUMPING THROUGH ALUMINUM PIPE.
6. REINFORCING BARS SHALL CONFORM TO ASTM SPECIFICATIONS A-615, GRADE 60.
7. ALL LAPS FOR REBAR, WHEN NOT DIMENSIONED ON DRAWINGS, SHALL BE 40 BAR DIAMETERS.
8. UNLESS OTHERWISE NOTED, PRINCIPAL REINFORCEMENT SHALL HAVE THE FOLLOWING CONCRETE PROTECTION:
 - a. SURFACES NOT FORMED - 3" COVER MINIMUM.
 - b. FORMED SURFACES IN CONTACT WITH SOIL OR WATER OR EXPOSED TO WEATHER - 2" COVER MINIMUM.

NOTES

1. MAX. DRYER OPERATING WEIGHT = 110,000#
2. DESIGN WIND SPEED: 80 MPH (35 PSF)
3. DESIGN SOIL PRESSURE: 3,000 PSF (SOILS ENGINEER TO VERIFY)
4. CONCRETE: F'c = 3,000 PSI, AIR ENTRAINED (0% +/- 1%)

Model CF 410/420

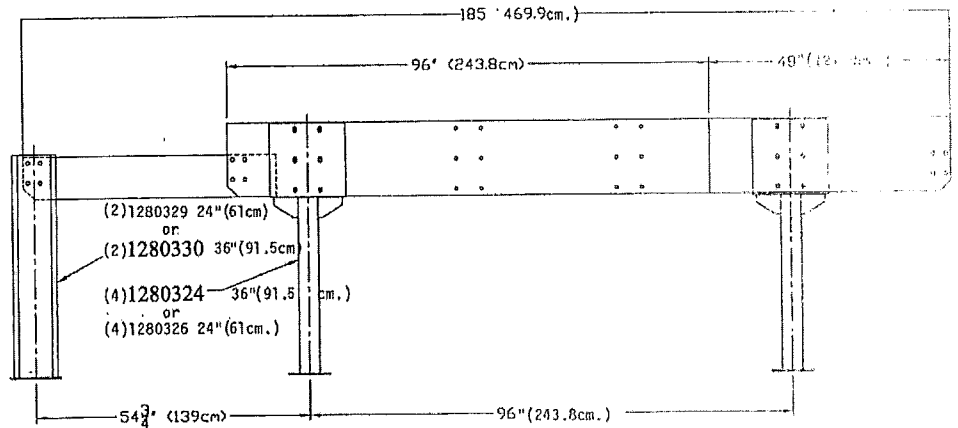
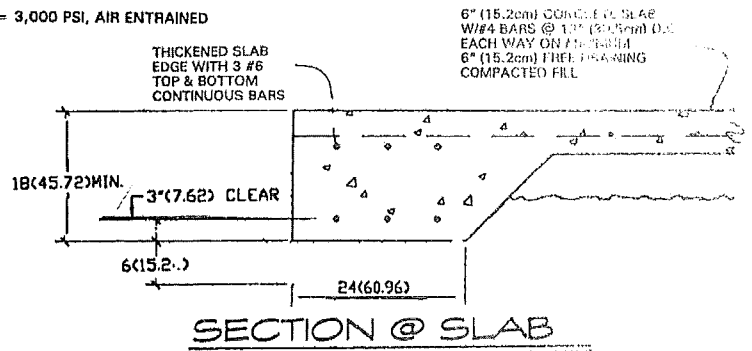
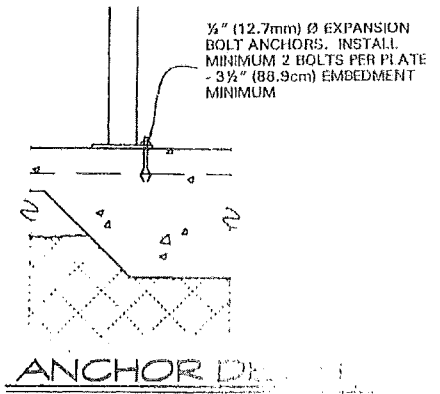

CF 410 & 420 STAND KIT PLACEMENT

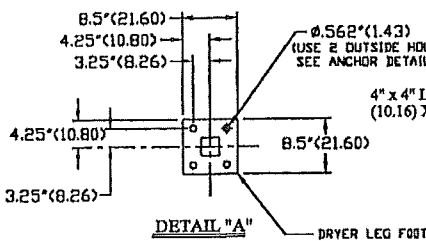
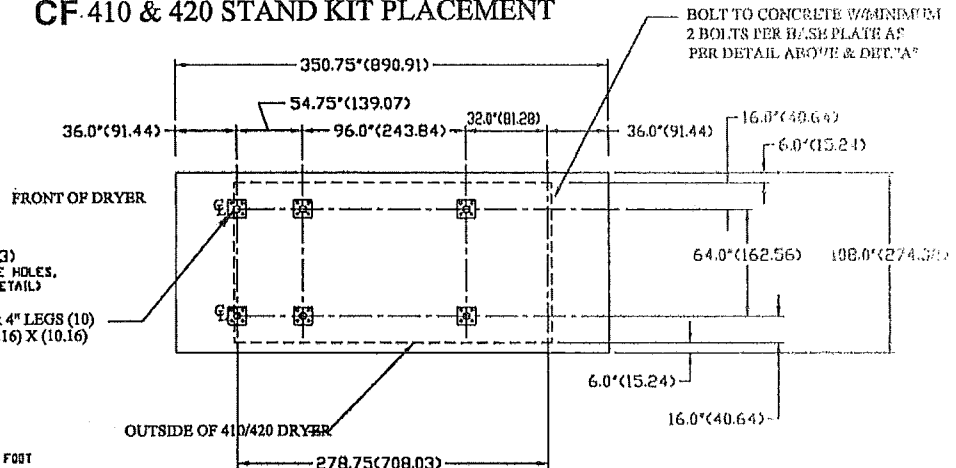

GENERAL NOTES

GENERAL

1. REFER TO DESIGN LOADS LISTED BELOW.
2. CONTRACTORS TO ASSUME FULL RESPONSIBILITY FOR:
 - a. COMPLIANCE WITH THE CONTRACT DOCUMENTS.
 - b. DIMENSIONS TO BE CONFIRMED AND CORRELATED ON THE JOB SITE AND BETWEEN INDIVIDUAL DRAWINGS OR SET OF DRAWINGS.
 - c. FABRICATION PROCESSES AND CONSTRUCTION TECHNIQUES (INCLUDING EXCAVATION, SHORING, SCAFFOLDING, BRACING, ERECTION, FORMWORK, ETC.)
 - d. COORDINATION OF THE VARIOUS TRADES.
 - e. SAFE CONDITIONS ON THE JOB SITE.
3. UNLESS OTHERWISE NOTED, ALL DETAILS, SECTIONS, AND NOTES ON THE DRAWINGS ARE INTENDED TO BE TYPICAL FOR SIMILAR SITUATIONS ELSEWHERE.

FOUNDATIONS

1. FOOTINGS ARE DESIGNED FOR A MINIMUM SOIL BEARING CAPACITY OF 3,000 PSF.
2. ALL FOUNDATIONS SHALL BE CARRIED DOWN TO DEPTHS SHOWN ON THE DRAWINGS, OR DEEPER, IF NECESSARY TO REACH UNDISTURBED SOIL OF DESIGN CAPACITY.
3. APPROVED FILL MATERIAL IN LOCATIONS WHERE ENGINEERED FILL IS REQUIRED TO OBTAIN PROPER FOUNDATION BEARING CONDITIONS SHALL BE PLACED IN LAYERS NOT EXCEEDING 9" IN LOOSE THICKNESS AND COMPACTED TO A MINIMUM OF 95% OF THE MAXIMUM DENSITY OBTAINED IN ACCORDANCE WITH ASTM SPECIFICATION D1557, MODIFIED PROCTOR METHOD, LATEST EDITION.
4. BENEATH SILO AREA SUBGRADE PREPARATION SHALL INCLUDE THE REMOVAL OF ALL UNSUITABLE SURFACE SOILS INCLUDING SOFT CLAYS, HIGHLY ORGANIC TOPSOIL, ROOT MATTER, DEBRIS AND OTHER DELETERIOUS MATERIALS.
5. IF FILL MATERIAL IS REQUIRED, THE ZONE OF COMPACTED FILL SHALL EXTEND BEYOND THE EDGES OF THE FOOTING A DISTANCE OF ONE FOOT FOR EACH FOOT OF THICKNESS COMPACTED FILL BELOW THE FOOTINGS.

CONCRETE

1. CONCRETE WORK SHALL CONFORM TO:
 - a. ACI 318-89, R92 STANDARD BUILDING CODE REQUIREMENTS FOR REINFORCED CONCRETE.
 - b. ACI 301, SPECIFICATION FOR STRUCTURAL CONCRETE IN BUILDINGS.
2. ULTIMATE COMPRESSIVE STRENGTH OF PORTLAND CONCRETE, STANDARD WEIGHT, AT 28 DAYS, SHALL BE 3,000 PSI, AIR ENTRAINED (6% +/- 1%)
3. CONCRETE CONTRACTOR SHALL NOT POUR ANY CONCRETE IN ADVERSE WEATHER CONDITIONS OR WHEN SUCH ARE FORECAST FOR THE TIME PERIOD FOLLOWING THE POUR UNLESS PROPER CURING AND PROTECTION IS PROVIDED CONTINUOUSLY UNTIL CONCRETE DEVELOPS ITS DESIGN STRENGTH.
4. CONCRETE CONTRACTOR SHALL SUPERVISE ALL TRADES REGARDING PIPING, ELECTRICAL CONDUIT, FIXTURE INSERTS, ANCHORS, ETC., PASSING THRU CONCRETE. BARS SHALL NOT BE CUT OR DISPLACED UNLESS ABSOLUTELY NECESSARY, AND THEN ONLY BY CONCRETE CONTRACTOR. MATCHING BARS EQUAL TO CUT BARS SHALL BE ADDED WITH PROPER LAPS AND EMBEDMENTS. CLEAR DISTANCE BETWEEN SLEEVES SHALL BE MINIMUM OF 8".
5. NO ALUMINUM OF ANY TYPE SHALL BE ALLOWED IN THE CONCRETE WORK UNLESS COATED TO PREVENT ALUMINUM-CONCRETE REACTION. THIS INCLUDES PUMPING THROUGH ALUMINUM PIPE.
6. REINFORCING BARS SHALL CONFORM TO ASTM SPECIFICATIONS A-615, GRADE 60.
7. ALL LAPS FOR REBAR, WHEN NOT DIMENSIONED ON DRAWINGS, SHALL BE 40 BAR DIAMETERS.
8. UNLESS OTHERWISE NOTED, PRINCIPAL REINFORCEMENT SHALL HAVE THE FOLLOWING CONCRETE PROTECTION:
 - a. SURFACES NOT FORMED - 3" COVER MINIMUM.
 - b. FORMED SURFACES IN CONTACT WITH SOIL OR WATER OR EXPOSED TO WEATHER - 2" COVER MINIMUM.

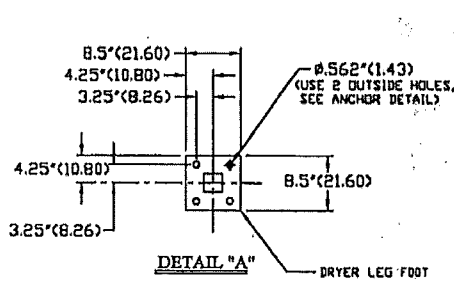

NOTES

1. MAX. DRYER OPERATING WEIGHT - 110,000#
2. DESIGN WIND SPEED: 80 MPH (35 PSF)
3. DESIGN SOIL PRESSURE: 3,000 PSF (SOILS ENGINEER TO VERIFY)
4. CONCRETE: F'c = 3,000 PSI, AIR ENTRAINED (6% +/- 1%)

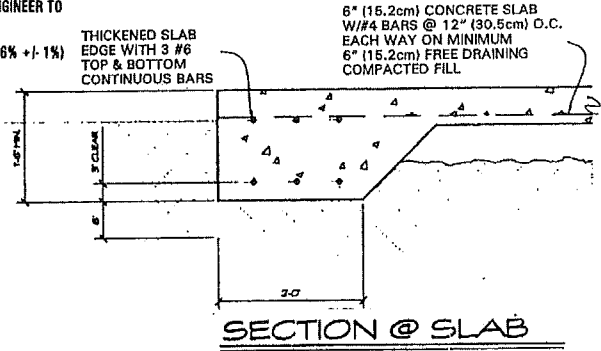
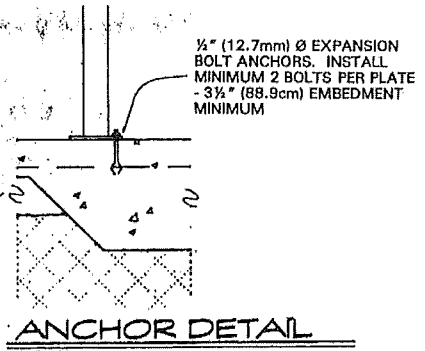

- 1280329 - 24" (61CM) Front Stand Weldment
- 1280326 - 24" Dryer Stand Weldment
- 1280330 - 36" (91.5cm) Front Stand Weldment
- 1280324 - 36" Dryer Stand Weldment

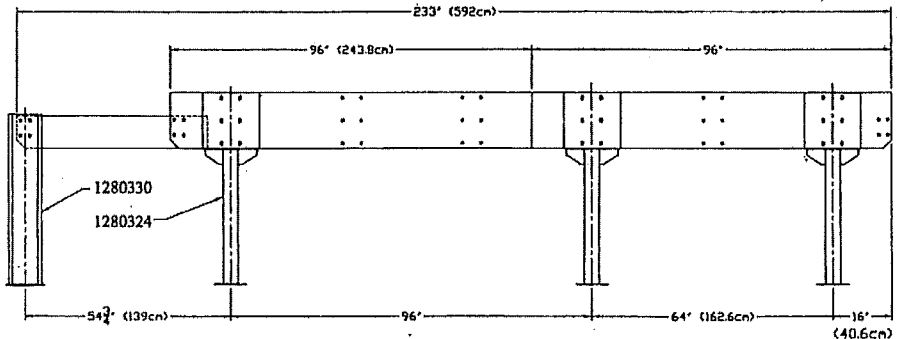

CF520 / 620 / 720 STAND (LEG) KIT PLACEMENT

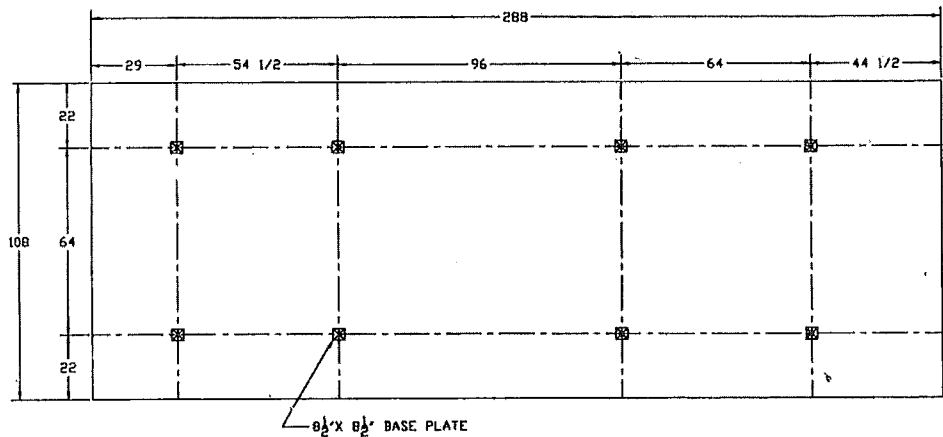

16 FT. (4.87m.) FOUNDATION LAYOUT STAND (LEG) KIT

	DATE	1-19-99	DESIGNER	9877		FOUNDATION DESIGN FOR: Models CF520 / 620 / 720 MATHEWS COMPANY - 500 Industrial Ave., Crystal Lake, Illinois 60012
	MARK ELMORE ASSOCIATES ARCHITECTS 7707 Northland Highway Crystal Lake, Illinois 60012 Phone: 815.452.7200 Fax: 815.452.2200					

GENERAL NOTES

GENERAL

1. REFER TO DESIGN LOADS LISTED BELOW.
2. CONTRACTORS TO ASSUME FULL RESPONSIBILITY FOR:
 - a. COMPLIANCE WITH THE CONTRACT DOCUMENTS.
 - b. DIMENSIONS TO BE CONFIRMED AND CORRELATED ON THE JOB SITE AND BETWEEN INDIVIDUAL DRAWINGS OR SET OF DRAWINGS.
 - c. FABRICATION PROCESSES AND CONSTRUCTION TECHNIQUES (INCLUDING EXCAVATION, SHORING, SCAFFOLDING, BRACING, ERECTION, FORMWORK, ETC.)
 - d. COORDINATION OF THE VARIOUS TRADES.
 - e. SAFE CONDITIONS ON THE JOB SITE.
3. UNLESS OTHERWISE NOTED, ALL DETAILS, SECTIONS, AND NOTES ON THE DRAWINGS ARE INTENDED TO BE TYPICAL FOR SIMILAR SITUATIONS ELSEWHERE.

FOUNDATIONS

1. FOOTINGS ARE DESIGNED FOR A MINIMUM SOIL BEARING CAPACITY OF 3,000 PSF.
2. ALL FOUNDATIONS SHALL BE CARRIED DOWN TO DEPTHS SHOWN ON THE DRAWINGS, OR DEEPER, IF NECESSARY TO REACH UNDISTURBED SOIL OF DESIGN CAPACITY.
3. APPROVED FILL MATERIAL IN LOCATIONS WHERE ENGINEERED FILL IS REQUIRED TO OBTAIN PROPER FOUNDATION BEARING CONDITIONS SHALL BE PLACED IN LAYERS NOT EXCEEDING 9" IN LOOSE THICKNESS AND COMPACTED TO A MINIMUM OF 95% OF THE MAXIMUM DENSITY OBTAINED IN ACCORDANCE WITH ASTM SPECIFICATION D1557, MODIFIED PROCTOR METHOD, LATEST EDITION.
4. BENEATH SILO AREA SUBGRADE PREPARATION SHALL INCLUDE THE REMOVAL OF ALL UNSUITABLE SURFACE SOILS INCLUDING SOFT CLAYS, HIGHLY ORGANIC TOPSOIL, ROOT MATTER, DEBRIS AND OTHER DELETERIOUS MATERIALS.
5. IF FILL MATERIAL IS REQUIRED, THE ZONE OF COMPACTED FILL SHALL EXTEND BEYOND THE EDGES OF THE FOOTING A DISTANCE OF ONE FOOT FOR EACH FOOT OF THICKNESS COMPACTED FILL BELOW THE FOOTINGS.

CONCRETE

1. CONCRETE WORK SHALL CONFORM TO:
 - a. ACI 318-89, R92 STANDARD BUILDING CODE REQUIREMENTS FOR REINFORCED CONCRETE.
 - b. ACI 301, SPECIFICATION FOR STRUCTURAL CONCRETE IN BUILDINGS.
2. ULTIMATE COMPRESSIVE STRENGTH OF PORTLAND CONCRETE, STANDARD WEIGHT, AT 28 DAYS, SHALL BE 3,000 PSI, AIR ENTRAINED (6% +/- 1%)
3. CONCRETE CONTRACTOR SHALL NOT POUR ANY CONCRETE IN ADVERSE WEATHER CONDITIONS OR WHEN SUCH ARE FORECAST FOR THE TIME PERIOD FOLLOWING THE POUR UNLESS PROPER CURING AND PROTECTION IS PROVIDED CONTINUOUSLY UNTIL CONCRETE DEVELOPS ITS DESIGN STRENGTH.
4. CONCRETE CONTRACTOR SHALL SUPERVISE ALL TRADES REGARDING PIPING, ELECTRICAL CONDUIT, FIXTURE INSERTS, ANCHORS, ETC., PASSING THRU CONCRETE. BARS SHALL NOT BE CUT OR DISPLACED UNLESS ABSOLUTELY NECESSARY, AND THEN ONLY BY CONCRETE CONTRACTOR. MATCHING BARS EQUAL TO CUT BARS SHALL BE ADDED WITH PROPER LAPS AND EMBEDMENTS. CLEAR DISTANCE BETWEEN SLEEVES SHALL BE MINIMUM OF 8".

5. NO ALUMINUM OF ANY TYPE SHALL BE ALLOWED IN THE CONCRETE WORK UNLESS COATED TO PREVENT ALUMINUM-CONCRETE REACTION. THIS INCLUDES PUMPING THROUGH ALUMINUM PIPE.
6. REINFORCING BARS SHALL CONFORM TO ASTM SPECIFICATIONS A-615, GRADE 60.
7. ALL LAPS FOR REBAR, WHEN NOT DIMENSIONED ON DRAWINGS, SHALL BE 40 BAR DIAMETERS.
8. UNLESS OTHERWISE NOTED, PRINCIPAL REINFORCEMENT SHALL HAVE THE FOLLOWING CONCRETE PROTECTION:
 - a. SURFACES NOT FORMED - 3" COVER MINIMUM.
 - b. FORMED SURFACES IN CONTACT WITH SOIL OR WATER OR EXPOSED TO WEATHER - 2" COVER MINIMUM.

NOTES

1. MAX. DRYER OPERATING WEIGHT = 110,000#
2. DESIGN WIND SPEED: 80 MPH (35 PSF)
3. DESIGN SOIL PRESSURE: 3,000 PSF (SOILS ENGINEER TO VERIFY)
4. CONCRETE: F'c = 3,000 PSI, AIR ENTRAINED (6% +/- 1%)

Model CF 730

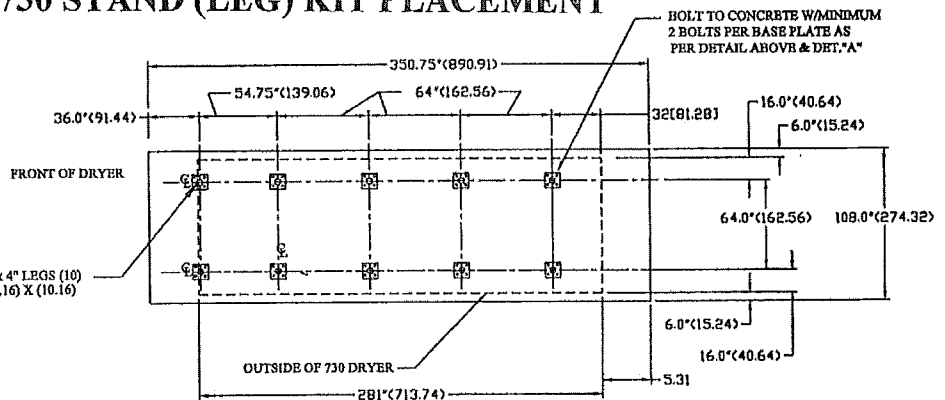
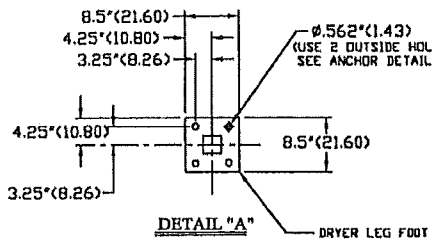
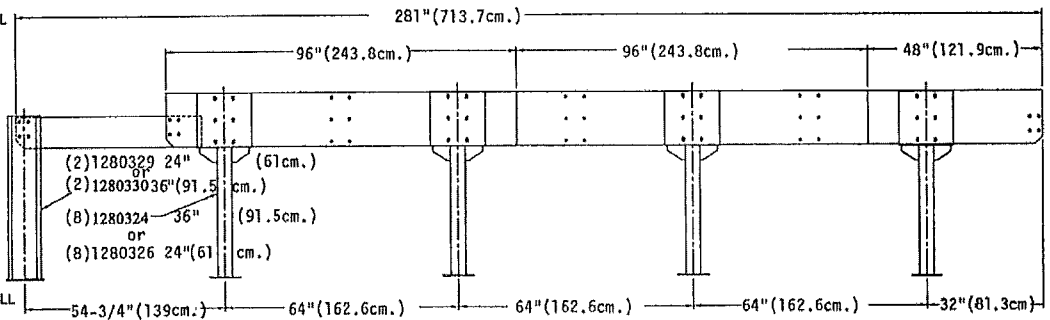
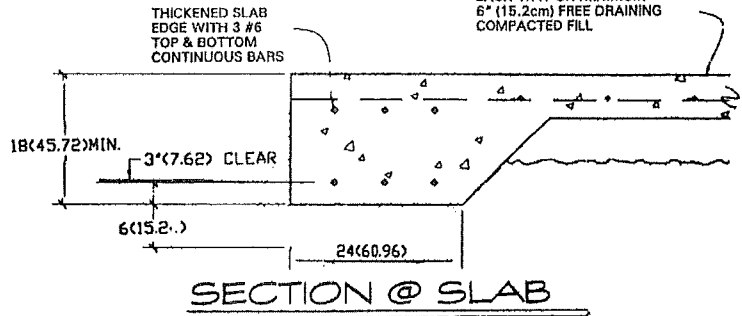
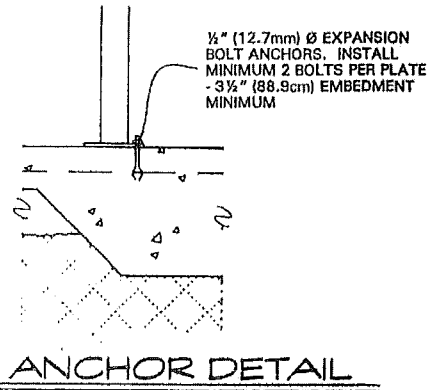

GENERAL NOTES

GENERAL

1. REFER TO DESIGN LOADS LISTED BELOW.
2. CONTRACTORS TO ASSUME FULL RESPONSIBILITY FOR:
 - a. COMPLIANCE WITH THE CONTRACT DOCUMENTS.
 - b. DIMENSIONS TO BE CONFIRMED AND CORRELATED ON THE JOB SITE AND BETWEEN INDIVIDUAL DRAWINGS OR SET OF DRAWINGS.
 - c. FABRICATION PROCESSES AND CONSTRUCTION TECHNIQUES (INCLUDING EXCAVATION, SHORING, SCAFFOLDING, BRACING, ERECTION, FORMWORK, ETC.)
 - d. COORDINATION OF THE VARIOUS TRADES.
 - e. SAFE CONDITIONS ON THE JOB SITE.
3. UNLESS OTHERWISE NOTED, ALL DETAILS, SECTIONS, AND NOTES ON THE DRAWINGS ARE INTENDED TO BE TYPICAL FOR SIMILAR SITUATIONS ELSEWHERE.

FOUNDATIONS

1. FOOTINGS ARE DESIGNED FOR A MINIMUM SOIL BEARING CAPACITY OF 3,000 PSF.
2. ALL FOUNDATIONS SHALL BE CARRIED DOWN TO DEPTHS SHOWN ON THE DRAWINGS, OR DEEPER, IF NECESSARY TO REACH UNDISTURBED SOIL OF DESIGN CAPACITY.
3. APPROVED FILL MATERIAL IN LOCATIONS WHERE ENGINEERED FILL IS REQUIRED TO OBTAIN PROPER FOUNDATION BEARING CONDITIONS SHALL BE PLACED IN LAYERS NOT EXCEEDING 9" IN LOOSE THICKNESS AND COMPACTED TO A MINIMUM OF 95% OF THE MAXIMUM DENSITY OBTAINED IN ACCORDANCE WITH ASTM SPECIFICATION D1557, MODIFIED PROCTOR METHOD, LATEST EDITION.
4. BENEATH SILO AREA SUBGRADE PREPARATION SHALL INCLUDE THE REMOVAL OF ALL UNSUITABLE SURFACE SOILS INCLUDING SOFT CLAYS, HIGHLY ORGANIC TOPSOIL, ROOT MATTER, DEBRIS AND OTHER DELETERIOUS MATERIALS.
5. IF FILL MATERIAL IS REQUIRED, THE ZONE OF COMPACTED FILL SHALL EXTEND BEYOND THE EDGES OF THE FOOTING A DISTANCE OF ONE FOOT FOR EACH FOOT OF THICKNESS COMPACTED FILL BELOW THE FOOTINGS.

CONCRETE

1. CONCRETE WORK SHALL CONFORM TO:
 - a. ACI 318-89, R92 STANDARD BUILDING CODE REQUIREMENTS FOR REINFORCED CONCRETE.
 - b. ACI 301, SPECIFICATION FOR STRUCTURAL CONCRETE IN BUILDINGS.
2. ULTIMATE COMPRESSIVE STRENGTH OF PORTLAND CONCRETE, STANDARD WEIGHT, AT 28 DAYS, SHALL BE 3,000 PSI, AIR ENTRAINED (6% +/- 1%)
3. CONCRETE CONTRACTOR SHALL NOT POUR ANY CONCRETE IN ADVERSE WEATHER CONDITIONS OR WHEN SUCH ARE FORECAST FOR THE TIME PERIOD FOLLOWING THE POUR UNLESS PROPER CURING AND PROTECTION IS PROVIDED CONTINUOUSLY UNTIL CONCRETE DEVELOPS ITS DESIGN STRENGTH.
4. CONCRETE CONTRACTOR SHALL SUPERVISE ALL TRADES REGARDING PIPING, ELECTRICAL CONDUIT, FIXTURE INSERTS, ANCHORS, ETC., PASSING THRU CONCRETE. BARS SHALL NOT BE CUT OR DISPLACED UNLESS ABSOLUTELY NECESSARY, AND THEN ONLY BY CONCRETE CONTRACTOR. MATCHING BARS EQUAL TO CUT BARS SHALL BE ADDED WITH PROPER LAPS AND EMBEDMENTS. CLEAR DISTANCE BETWEEN SLEEVES SHALL BE MINIMUM OF 8".
5. NO ALUMINUM OF ANY TYPE SHALL BE ALLOWED IN THE CONCRETE WORK UNLESS COATED TO PREVENT ALUMINUM-CONCRETE REACTION. THIS INCLUDES PUMPING THROUGH ALUMINUM PIPE.
6. REINFORCING BARS SHALL CONFORM TO ASTM SPECIFICATIONS A-615, GRADE 60.
7. ALL LAPS FOR REBAR, WHEN NOT DIMENSIONED ON DRAWINGS, SHALL BE 40 BAR DIAMETERS.
8. UNLESS OTHERWISE NOTED, PRINCIPAL REINFORCEMENT SHALL HAVE THE FOLLOWING CONCRETE PROTECTION:

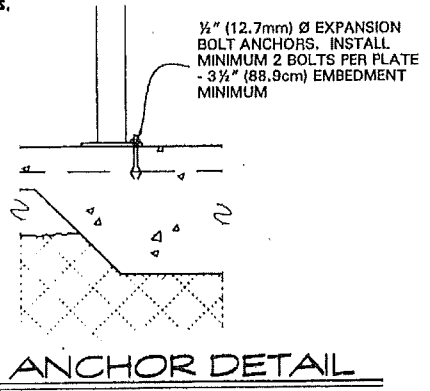
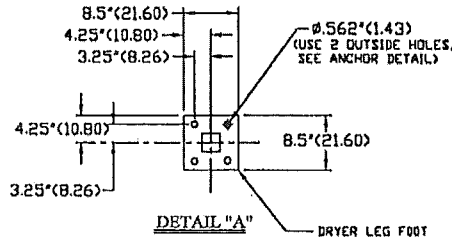

NOTES

1. MAX. DRYER OPERATING WEIGHT = 110,000#
2. DESIGN WIND SPEED: 80 MPH (35 PSF)
3. DESIGN SOIL PRESSURE: 3,000 PSF (SOILS ENGINEER TO VERIFY)
4. CONCRETE: $f'_c = 3,000$ PSI, AIR ENTRAINED (6% +/- 1%)

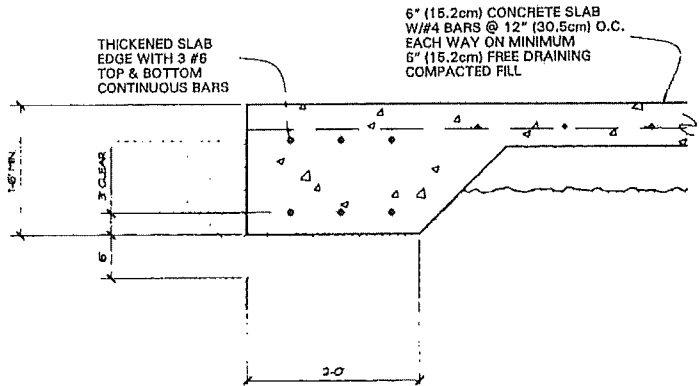

SECTION @ SLAB

- 1280329 - 24" (61cm) Front Stand Weldment
- 1280326 - 24" Dryer Stand Weldment
- 1280330 - 36" (91.5cm) Front Stand Weldment
- 1280324 - 36" Dryer Stand Weldment

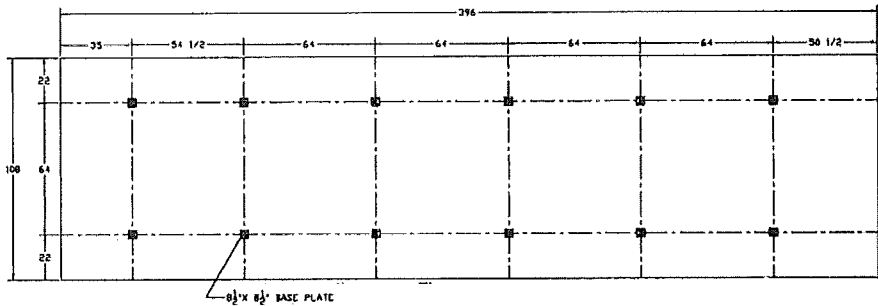
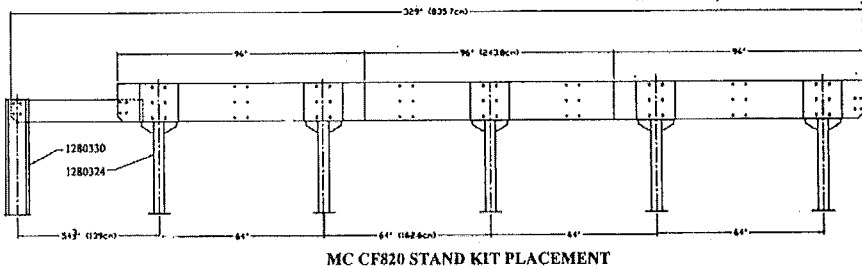

FOUNDATION DESIGN FOR:
Model CF820
 MATHEWS COMPANY - 500 Industrial Ave., Crystal Lake, Illinois 60012

Electrical Components

Infinity Series

CF320, 410, 420, 520, 620, 720, 730 & 820

Starting with S/N 58161

Part No.	Description	Part No.	Description
120 6800	Unload Switch	127 6823	Neutral Lug
121 6849	Air Pressure Switch	124 6978	60 Minute Adjustable Timer
125 6967	High Limit Switch - 8 ft. (2.4m) Cap.	124 6874	SCR Board (Dart)
125 6965	115V Ignition Board	124 6837	1/3HP DC Motor
128 6995	Style 2 Electrode	128 6957	Splitter Block
124 6872	Flame Sensing Probe	128 6992	Level Switch-Diaphragm Type
Terminal Block		127 6855	Transformer-208V (750VA)
124 6928	12 Position (Black)	127 6829	Transformer-460/575V (750VA)
124 6929	3 Position (White)	125 6997	13 Amp (208V) Circuit Breaker
125 6805	4 Position (Black)	125 6993	4 Amp (460V) Circuit Breaker
115V LP Gas Solenoid Valves		125	4 Amp (575V) Circuit Breaker
125 7082	½" (12.7mm) Solenoid Valve LP Liquid Line	124 1195	SCR Speed Control 10 Turn Potentiometer w/Wires 42" (107cm)
123 7036	½" (12.7mm) Solenoid Valve (Canadian)	124 6892	Multi-Dial
121 7002	¾" (19mm) Solenoid Valve Low Fire Manifold	124 6893	Thermistor
123 7037	¾" (19mm) Solenoid Valve (Canadian)	124 6955	Moisture Control Potentiometer w/Wires 60" (152cm)
128 7001	1 ¼" (31.8mm) Solenoid Valve Gas Manifold	121 6805	10 Amp. GLH Fuse (SCR Board)
123 7038	1 ¼" (31.8mm) Solenoid Valve (Canadian)	124 6995	Moisture Control Board
115V Natural Gas Solenoid Valves		124 6981	Discharge Meter
121 7002	¾" (19mm) Solenoid Valve Low Fire Manifold	124 6958	Digital Thermometer Main Frame °F
123 7037	¾" (19mm) Solenoid Valve (Canadian)	123 6920	Digital Thermometer Main Frame °C
128 7001	1 ¼" (31.75mm) Solenoid Valve Gas Manifold	124 6961	Thermocouple 15 ft. (4.6m) Digital Thermometer
123 7038	1 ¼" (31.8mm) Solenoid Valve (Canadian)	125 6936	Fuse Holder for 124 6937 & 125 6838
125 6988	8 Amp Circuit Breaker 115V Pole	124 6937	1 Amp. Fuse-Slow Blow (Moisture Control Board & Printer Power Supply)
128 6845	Stop Button (Red)	125 6838	¾Amp. Fuse (Monitor Power Supply)
128 6844	Start Button (Green)	122 7066	Monitor Interface Board °Fahrenheit
125 6808	125V Indicator Lamp Assembly	122 7067	Monitor Interface Board °Celsius
125 6812	SPST ON-OFF Switch (Ignition)	122 7071	Printer Interface Board °Fahrenheit
125 6811	3PDT ON-OFF-ON Switch (Discharge Metering Rolls)	122 7072	Printer Interface Board °Celsius
125 6809	Momentary Contact Switch	122 7065	Monitor Power Supply
125 6810	DPDT ON-OFF-ON Switch (Level Auger)	122 7070	Printer Power Supply
124 6996	0 to 3 Minute Adj. Timer (Level Auger)	122 7074	Printer Assembly
124 6841	Light Bulb Socket	125 6839	Switch ON-OFF Printer
124 6842	50W Rough Service Bulb	128 7016	Grain Sensor w/40 ft. (12.2m) Cable - Monitor
124 6972	Relay and Timer Socket	122 7061	Thermal Paper 3 ⅝" x246 ft. (7.94cm x 75m)
021 6809	Relay	122 7069	Calibration Adjust. Potentiometer
		125 6834	Push Button for Calibration & Grain Temperature Display
		122 7068	Digital Display Meter-Monitor
		121 6840	Low Pressure Gas Interlock Switch (Canadian)
		121 6841	Low Pressure Gas Interlock Transducer (Canadian)
		124 6916	High Pressure Gas Interlock Switch (Canadian)
		124 6917	High Pressure Gas Interlock Transducer (Canadian)

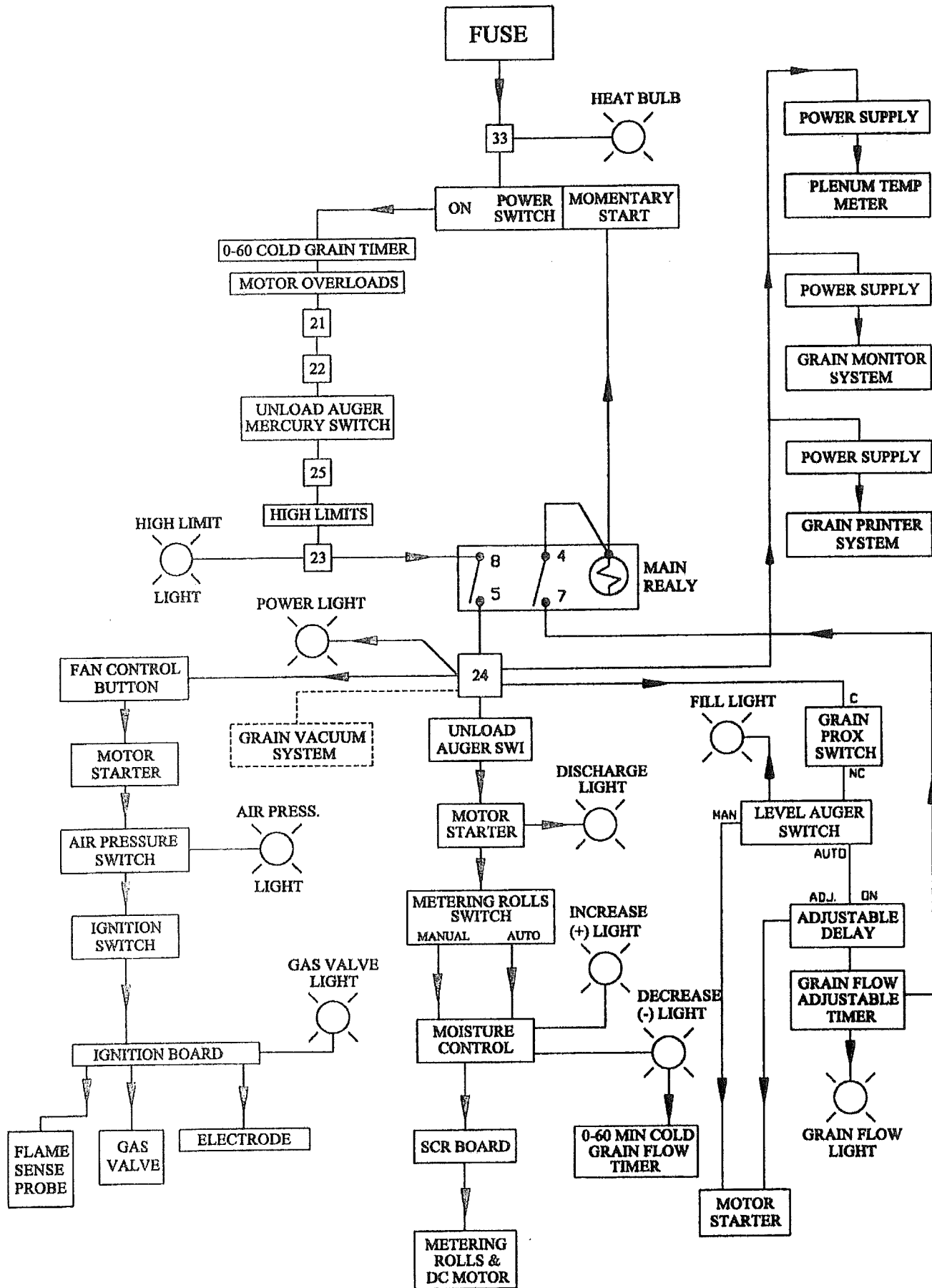

<h1>MC FLOW CHART</h1>	MC INFINITY SERIES		START S/N	
	ALL DRYERS		REVISED 07-05-2001	PG.1