

VARIABLE PULLEY ASSEMBLY No. 4430

Ref. No.	Part No.	Description	Ref. No.	Part No.	Description
1		#10-32 x 1/2" Lg. Round Head Screw	16	4501	Pulley Shaft
2		1/4" Lockwasher	17	4438	Bronze Bushing
3	4512	Finished Washer (Special)	18	4437	Snap Ring
4	4511	Hand Wheel	19	4442	Shaft
5	4509	Thrust Ball Bearing	20	4431	Stationary Sheave Face
6	4507	Control Stand	21	4440	Bronze Bushing 1 1/2" Lg.
7	4518	Control Barrel	22	4432	Movable Sheave Face
8	4514	Thrust Collar	23	4433	Spring Loaded Sheave Face
9	4508	1/8" Dia. Steel Balls, 12 Req'd	24	4439	Bronze Bushing 1-1/8" Lg.
10	4513	Woodruff Key	25	4441	3/16 x 3/16 x 4 1/2" Lg. Key
11	4517	Control Stem	26	4441	Spring Retainer (-3/8" Hole)
12	4511	Control Shaft	27	4436	Spring
13	4514	Hollow Head Screw #10-32 (Special)	28	4434	Spring Retainer (sp 1" Hole)
14	4378	3/16 x 1 1/2" Lg. Roll Pin	29	4444	Lock Collar
15	4502	Control Arm Casting	30	4519	Oil Cup

M-C

..... continuous

Grain Dryers

MODELS 300 400 600 800
for serial no.

ASSEMBLY-OPERATION AND MAINTENANCE INSTRUCTIONS

MATHEWS COMPANY CRYSTAL LAKE, ILLINOIS 60014 U.S.A.

MISCELLANEOUS - (con't)

<u>Part No.</u>	<u>Description</u>
2165	Side Panels Upper Hopper
2216	P. T. O. Shield
4150	Shear Flange - Side Auger Sprocket, 3/16" dia. shear pin hole
0017650	P.T.O. Shear Flange
4245	Ladder, 7-1/2'
4247	Ladder, 3'
4255	Lock Collar, 1"
4265	Lock Collar, 1-1/4"
4310	Magnetic Catch for Level Switch
4491	Safety Snap Ring for Eccentric Sprocket 3/4"
4495*	Safety Snap Ring for Eccentric Sprocket 1"
0016600	P.T.O. Drive Shaft
4540*	Thermometer - Not on 1963 Models and Later
4595	Universal Joint (Unloading Auger)
4596	P.T.O. Shaft (Unloading Auger)
0018993	Wheel, 15", 5 Bolt - Rim only
0018992	Wheel, Hub, Assy, (5)(includes casting, inner & outer Bearing cups.)
4670	Ratchet Wheel for Feed Rolls
4675	Chain Guide Wood Block

* Give Serial No. of Dryer When Ordering These Parts.

MISCELLANEOUS

<u>Part No.</u>	<u>Description</u>
10	Auger Bearing Weldment, 1-1/4"
15*	Eccentric Sprocket Mounting Bracket, 1" Shaft
20	Eccentric Sprocket Weldment
21	Eccentric Sprocket Mount Weldment, 3/4" Shaft
25	Eccentric Arm Weldment
52	Ratchet Arm Guide
61	Ratchet Dog Weldment
85	Level Auger Center Brg. Bracket
120	Wheel Spindle with Mounting Block
805	Ratchet Arm Weldment
825	Front Fan Guard
830	Rear Fan Guard
895	Electric Motor Mount Kit
926	Extension Hopper Cross Brace
963	Unloading Auger Canvas Boot Complete with Springs
1230	Inner Perforated Sheet
1245	Outer Perforated Sheet
1270	Grain Column Tie Brace, 1 x 14
1275	Grain Column Tie Brace, 1 x 12

* Give Serial No. of Dryer When Ordering These Parts.

Every M-C Grain Dryer is test run before leaving the factory. Inspection is made of all moving parts, and gas lines and control system are checked out. Therefore, your Dryer should function properly when it reaches you.

We advise that you set your Dryer in position and check it out before filling it with grain, in the event any damage may have occurred during shipment. The Dryer should be installed on level ground. If the ground is soft, lay planks on the ground spaced so that the skids of Dryer will rest firmly on them. Remove wheels or dig holes where wheels are to be located and pull Dryer into position. For permanent installations pour a concrete slab.

Advise your LP gas supplier that the Dryer takes liquid gas from the bottom of the tank (not vapor). When the gas dealer hooks up the system, have him use the No. 4605 excess flow valve (see gas flow diagram) furnished with the Dryer. The No. 4605 excess flow valve will shut off flow of gas should the line break between tank and Dryer. The valve furnished with the Dryer will shut off quicker than those normally furnished by the gas supplier. We provide the valve as an extra safety precaution. THE DRYER WILL NOT BE UNDER WARRANTY IF NO. 4605 VALVE IS NOT USED. Use a minimum of 1/2" I.D. tubing between tank and Dryer - on long runs use a larger diameter. Connect line from tank to short length of rubber hose on Dryer.

For natural gas operation you need a minimum of 5 lbs. operating pressure. If you hook up for natural gas, see separate instructions (Page 11).

After Dryer is set in place, bolt top hopper sections in place (see instructions on Page 13). Connect PTO shaft to tractor 540 RPM and 110 volt electric line to cord at lower left on control panel. For electrical leads over 50 feet (especially on models with leveling augers) be sure line is heavy enough to carry the load. For electric motor models, bring power line to magnetic starter. (See wiring diagram No. 40561A).

NOTE: Turn fan over by hand before starting motor to make sure all parts are running free. Start fans in operation to make sure they are running properly. The 3-way switch for unloading should be in the "off" position. (Ratchet pawls are then disengaged). Shut off fans and fill Dryer with grain. Enough grain should be put into Dryer to fill drying and cooling columns on sides and wet holding bin on top.

AUGERS AND FEED ROLLS

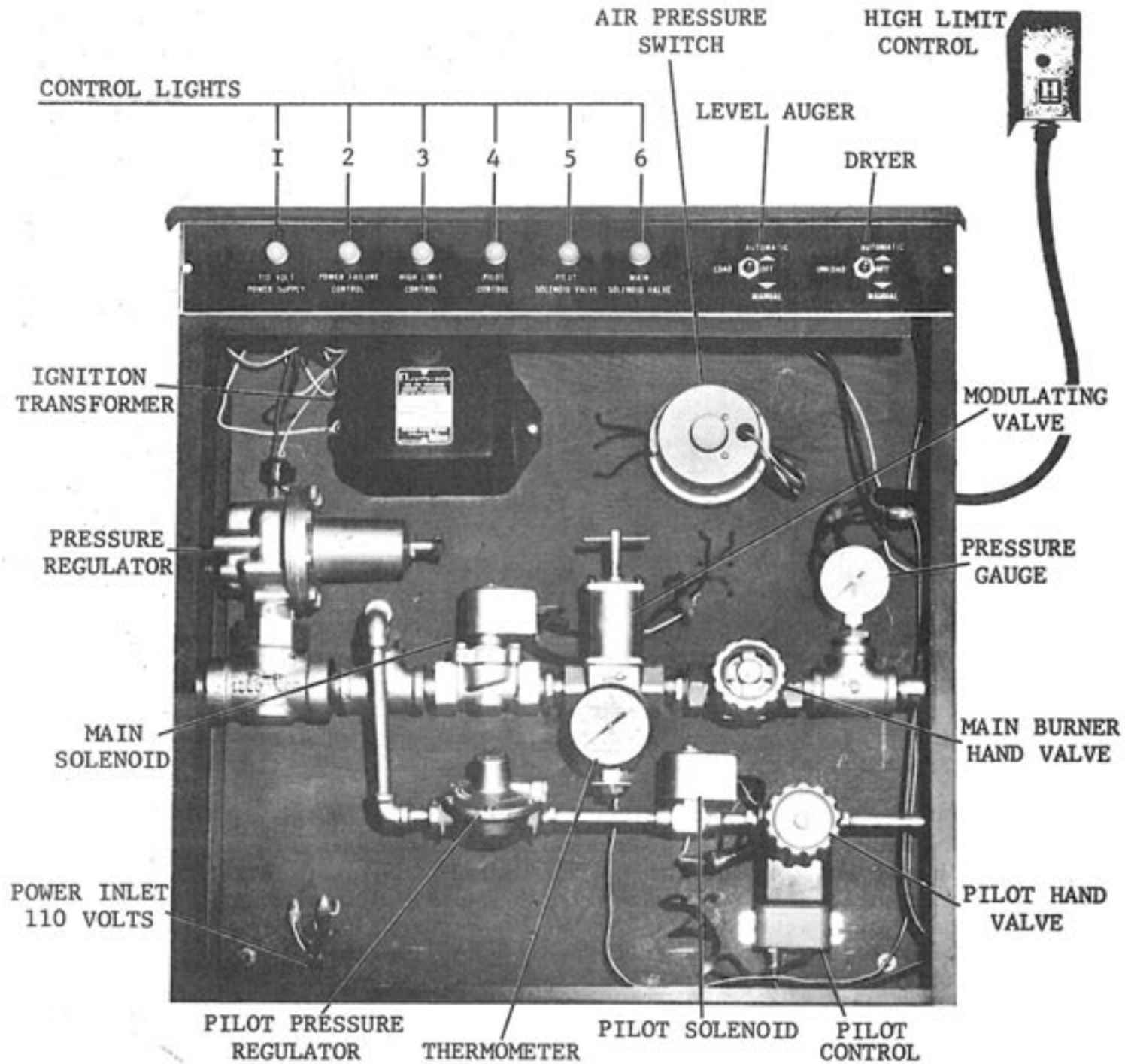

<u>Part No.</u>	<u>Description</u>
705	Side Auger Model 400 (front section)
706	Side Auger Model 600 (front section)
710	Side Auger Model 300
711	Side Auger Models 400 & 600 (rear section)
715	Feed Roll Model 400 (front section)
716	Feed Roll Model 600 (front section)
718	Feed Roll Models 400 & 600 (rear section)
720	Feed Roll Model 300
812	Right Hand Cross Auger - Models 300, 400, and 600 only
813	Left Hand Cross Auger - Models 300, 400, and 600 only
855	Cross Auger Assembly Complete
935	Rear Level Auger Section, Model 400
940	Front Level Auger Section, Models 400 & 600
945	Rear Level Auger Section, Model 600

<u>Part No.</u>	<u>Description</u>
001600	Bearing 3/4" (Double seal - eccentric sprocket)
4690	Hanger Bearing 1" (level auger)
0016000	Wheel outer bearing
4691	Hanger Bearing 1-1/4 (side auger)
0016001	Wheel Inner Bearing

SPROCKETS

20	Eccentric sprocket assembly with 0016006 bearings
30	Chain Idler Tightener, Sprocket Assembly
4460	Sprocket 16T x 1-1/4
4465	Sprocket 48T x 1-1/4
4470	Sprocket, 22T x 3/4 bore Models 400 & 600 (Unloading auger drive)
4471	Sprocket, 11T x 3/4 bore Models 400 & 600 (Unloading auger drive)
4475	Sprocket 22T x 1" bore (Unloading auger)
4485	Chain Tightener Idler Sprocket

ROLLER CHAINS

4105	Chain, RC 40 x 42" lg.
4110	Chain, RC 40 x 190-1/2" lg.
4115	Chain, RC 40 x 21-1/2 links (Unloading auger)

CONTROL PANEL - ELECTRIC & GAS CONTROL

The Control Panel consists of temperature and safety controls. There are six lights wired in series with the controls to indicate operation.

Control Lights

- No. 1 Lights when electric power is on.
- No. 2 Lights when fan is running (air pressure completes circuit to pilot valve letting gas flow to pilot).
- No. 3 Lights when high limit control circuit is closed. This indicates the high limit temperature safety device is operating.
- No. 4 Lights in 60 to 90 seconds after flame at pilot tip has heated thermocouple establishing circuit at pilot control.
- No. 5 Lights indicating pilot solenoid valve is open.
- No. 6 Lights when the temperature control calls for heat.

BELTS

READ THROUGH THE FOLLOWING INSTRUCTIONS BEFORE ATTEMPTING
TO RUN YOUR DRYER THE FIRST TIME

To Operate Dryer Follow This Procedure:

1. Start Fans in Operation. (PTO 540 RPM)
2. Open pilot hand valve.
3. When Light No. 4 and No. 6 come on, open main burner hand valve. Open only partially at first in cold weather until Dryer warms to avoid gas line frosting. Then set modulating valve to desired operating temperature. To increase temperature turn adjusting screw in, to decrease turn out. We recommend 180° for corn and milo, 160° for wheat, 120° for soybeans, barley and oats, 110° for seed grains.
4. When you start drying wet grain for the first time you must hold the grain in the Dryer before letting it come out. With the ratchet pawls of the grain feeding mechanism disengaged the grain will stay in the Dryer; however, the augers will be running. The 3-way switch for unloading should be in the "off" position. (Ratchet pawls will be disengaged). When drying 30% corn to 12% leave the grain in the Dryer for approximately 1-1/2 hours. This time varies with the moisture of the grain going in. Grain with less than 30% moisture will require less pre-heat time.
5. After a sufficient amount of time, engage the ratched pawls. The 3-way unloading switch should be placed in the "manual" position. This will drop the ratchet pawls into place and allow you to get your Dryer operating properly before setting it on Automatic Control.
6. The grain in the cooling section (the lower section of the side columns below the dividing floor) has not been subjected to hot air and must be run back through the Dryer. Once you have completed this cycle it is not necessary to do it again. You can leave grain in the Dryer when you stop at night and the next day you can start right out drying and cooling.

For dryer installations where it is not convenient to run

<u>Part No.</u>	<u>Description</u>
4065	Fan Drive Cogg Belts, BX97 - set of 4, matched.
4066	Fan Drive Belts BX97 - set of 5, matched.
4070	Variable Drive Belt (short) B48
4072	V-Belt - BX71, matched set of 4 -(electric drive)
4075	V Belt 5L580 Cross Auger - and level auger
4076	V-Belt, 5L590, matched set of two - double belt cross auger drive
4077	V-Belt, B x 71 Matched set of 5 (electric drive)
4080	V-Belt 5L510 - Unloading auger drive - not on 1963 models and later
4085	V-Belt B x 65 (Variable Drive)
4086	V-Belt 5L450 (U.A. Jackshaft Optional Drive)
4090	V-Belt B270-3T (level auger to fan opt. drive)
	<u>BEARINGS</u>
0016009	Flangette for 0016008 bearing
0016008	Bearing, one inch
0016007	Eccentric Lock collar - one inch bearing
0016003	Bearing - 1-1/4"
0016004	Flangette for 0016003 Bearing
0016002	Eccentric lock collar for 0016003 bearing
4030	3/4" Ball Bearing, Pillow Block complete
4035	1-1/4" Idler shaft bearing
0016011	Pillow Block Bearing 1-7/16"
4046	Bronze Bearing (Eccentric sprocket) - not on 1962 models and later.

<u>Part No.</u>	<u>Description</u>
4396	Drive Pulley 4B 18.4 P.D. x 1-7/16
4397	Pulley 4B 4.8 x 1-5/8 bore 15 HP elec. motor
4398	Pulley 4B 5.0 x 1-5/8 bore 20 HP elec. motor
4399	Pulley 4B 5.2 x 1-7/16 front and rear fan pulley (Model 800BE)
4400	V-Pulley 3.6 P.D. x 1-1/4 - not on 1963 models and later
4401	Pulley 4B 5.2 x 1-7/8 bore 25 HP elec. motor
4402	Pulley 5B 5.4 x 1-7/8 bore 30 HP elec. motor
4405	V-Pulley 4.5 OD x 1-7/16
4406	V-Pulley 4.4 P.D. x 1-7/16
4407	V-Pulley 4.0 x 3/4" bore (U.A. jackshaft opt. drive)
4410	V-Pulley 10" OD x 1-1/4
4411	V-Pulley 10" OD x 3/4 bore (U.A. jackshaft op. drive)
4415	V-Pulley 14" OD x 1-1/4
4418	Idler Pulley (level auger to fan opt. drive)
4420	V-Pulley 16" OD x 1"
4421	Drive Pulley - 5B 18.4 P.D. x 1-7/16 Bore
4422	Fan Pulley - 5B 6.4 P.D. x 1-7/16 bore
4425	V-Pulley 3.2 P.D. x 5/8 bore
4426	V-Pulley 3.2 P.D. x 7/8 bore
4430	Variable Drive Assembly

wet grains back, the trap door on the inside of the 400, 600 and 800 machines can be taken out, and a cardboard placed over the back fan at the beginning. In this manner, hot air will be delivered to all parts of the dryer. After about 1-1/4 hour replace trap door and remove cardboard. Run for another half hour before engaging ratchet pawls.

7. For safe bin storage practically all grains must be reduced to 13% moisture or less.

As the dried grain begins to come out of your Dryer, check it with a moisture tester for moisture content. If the moisture content is too high, slow the unloading mechanism down. If the moisture content is too low, increase the speed of the unloading mechanism.

NOTE: Wait for from 30 to 45 minutes after making adjustment before testing moisture again.

8. The speed of the unloading mechanism can be increased or decreased with a combination of two adjustments.
- The speed of the feed rolls and side augers can be adjusted together by turning the hand wheel on the "variable drive pulleys." Turn the hand wheel to the left to increase speed - to the right to decrease speed.
 - The feed rolls can be adjusted independently of the side augers by sliding the "eccentric connecting rod" along the slotted bracket on the eccentric sprocket. The eccentric sprocket is located at the center of the base on the drive end of the Dryer. Moving the eccentric connecting rod towards the center of the sprocket will decrease the stroke and slow down the feed rolls. Moving it away from the center of the sprocket will increase the stroke and speed up the feed rolls.

All Dryers are set at the factory to have the ratchet pawls engage one tooth on the ratchet wheels.

The variable speed pulleys are used for finer adjustments than you can obtain by setting the eccentric connecting rod.

IMPORTANT - ADJUST VARIABLE SPEED PULLEYS ONLY WHEN MACHINE IS

OPERATING. Variable drive will not operate (pulleys will not change diameter) if set screws in base are loose. The set screws hold sleeve tightly in base and must be secure. To find correct position for locking sleeve in base, turn hand wheel full to right.

Belt from fan shaft will be at maximum diameter of rear pulley. Belt to auger drive will be a minimum diameter of front pulley. Tighten set screws.

9. If you are drying at high capacity, taking out small amounts of moisture, it may be necessary to increase the speed of the unloading mechanism CONSIDERABLY. Turning the hand wheel on the variable speed drive pulleys to the left will increase the rate of feeding grain out of the Dryer. Should more unloading speed be needed (grain still coming out too dry), slide the eccentric connecting rod farther away from the center of the eccentric sprocket. This will cause the ratchet pawls to engage every second or third tooth on the feed roll ratchet wheels. In making these adjustments BE CAREFUL NOT TO RUN MORE GRAIN OUT OF THE FEED ROLLS THAN THE SIDE AUGERS CAN CARRY AWAY! Four teeth is about the maximum adjustment that the augers can handle.
10. Regulate your drying to correspond with your harvesting. If you find you cannot keep up with the Dryer, reduce the temperature of the air by using a lower temperature setting on the modulating valve, thus slowing the drying down. In this way you can operate very efficiently.
11. IMPORTANT: Never let the level of the grain in your Dryer go below the bottom edges of the upper wet holding bin. When this happens the air pressure inside of the Dryer will drop, and the heat will automatically shut off.

Your dryer is a Continuous Flow Dryer and it is necessary to HOLD THE GRAIN IN THE DRYER FOR A PERIOD OF TIME WHEN FINISHING A RUN. Ratchet pawls should be disengaged as described in Instruction No. 4. This will give the grain remaining in the Dryer time to become dried before the heat is automatically turned off. Allow about 30 minutes of drying time for high moisture grain (30%) and proportionately less for drier grain.

12. If you should accidentally get a foreign object in the

<u>Part No.</u>	<u>Description</u>
4941	Toggle Switch (automatic moisture control)
4957	Alarm Head - BEL Models
4959	Alarm Buzzer
4968	Ignition Delay Relay - BEL Models
4974	Relay - BEL Models
4985	Warning Light (Glass Globe Only)
<u>FANS AND SHAFTS</u>	
525	Front Fan - 12 Blade 35° - Models 400 and 600
526	Front Fan - 12 blade 28° - 300 only
527	Rear Fan - 12 blade 35° - Model 800
528	FRONT Fan 12 blade 42° - Model 800
530	Rear Fan- 9 blade 35° - Models 300, 400 and 600
2330	Rear Fan Shaft - 1-7/16 x 56 Model 400
2331	Rear Fan Shaft 1-7/16 x 56 Model 800
2335	Fan Shaft - 1-7/16 x 70 - Model 400, 600 and 800
2340	Fan Shaft, Model 300
4585	Universal Joint Shaft, Model 400 (Fan Shaft)
4590	Universal Joint Shaft, Model 600 and 800 (Fan Shaft)
<u>PULLEYS</u>	
4387	Pulley 2B4.0 x 1-1/4 (Cross Auger)
4395	Fan Pulley 4B 6.8 P.D. x 1-7/16.

<u>Part No.</u>	<u>Description</u>
4285*	High Limit Control 240°
4290*	Control cabinet light socket for NE 45 Bulb
4291*	Lamp Base for NE 51H Bulb
4293*	Lamp Assembly, Screw Type (Parts 4290 and 4300)
4294*	Lamp Assembly, Bayonet type (Parts 4291 and 4301)
4300*	Light bulb, control cabinet light panel NE 45
4301	Light bulb, control cabinet light panel NE 51H
4305	One HP Single Phase 1800RPM Motor
4306	1-1/2 HP 3 Phase 1800 RPM Motor
4307	Magnetic Starter for 4306
4375*	Pilot Safety Control
4376*	Thermocouple Lead Wire
4377*	Baso Pilot Safety Control
4385*	Ignition Push Button
4505	Spark Plug
4506	Ignition Wire
4520	Micro Switch (for level switch)
4525	3-Way Toggle Switch (level auger)
4530	Ignition Transformer
4535	Temperature Control - not on 1963 models and later
4924	Solenoid - Automatic Moisture Control, Feed Roll.
4927	Thermo-switch - Automatic Moisture Control.
4929	Tractor Cut-off relay

*Give Serial # when ordering these parts

grain feeding mechanism, the shear pin on sprocket No.4465 at lower left side (as you face drive end of Dryer) will help to protect the feeding parts from breakage. Replace this pin when necessary. Do not use a shear pin larger than the 3/16" Cotter Pin put on sprocket at the factory.

13. AFTER YOU HAVE YOUR DRYER OPERATING PROPERLY AND DRYING YOUR GRAIN TO THE DESIRED MOISTURE CONTENT, you are ready to switch it to "Automatic Moisture Control."

Refer to the following Chart if you are drying shelled corn and set your moisture control dials, located on each side of your Dryer, at the correct number

APPROXIMATE SETTING FOR SHELLED CORN

<u>Thermostat Setting</u>	<u>Set Control Dial At - -</u>	<u>To Get - - - Percent Moisture</u>
140°	3.5	13 - 14%
180°	4.0	14 - 15%
180°	4.5	13 - 14%
180°	5.0	12 - 13%

14. Place 3-way switch for unloading in the "Automatic Position".
15. When the combined temperatures of the air passing through the grain and the grain temperature are equal to the calibrated setting on the control dial, the ratchet pawls will engage the ratchet wheels and feed grain out of the Dryer. Check the moisture content of the grain coming out of EACH side auger by taking a moisture test. EACH SIDE OF THE DRYER SHOULD BE TESTED AND THE CONTROL DIAL FOR THAT SIDE ADJUSTED SEPARATELY. You will have to remove the bottoms of your rear cross auger housing to make these tests. Remove screw at ends of slide-in type bottoms and slide bottoms out. This will allow the grain to fall out for testing. Replace bottoms. If the moisture is too high, increase the setting of the control one point at a time until the correct moisture content is reached.

Adjust the grain unloading mechanism to correspond with the

rate of feeding of the grain by the Automatic Moisture Controls (see Instructions No. 9 and No. 10). These adjustments will be only slight if you have your Dryer operating correctly before switching it to "Automatic Moisture Control." The speed of the variable drive should be fast enough to cause the Automatic Moisture Controls to operate intermittently. If the unloading mechanism is working too slowly, then the moisture controls will operate constantly and the grain will come out drier than the chart indicates.

It is most desirable to have just enough speed on the unloading mechanism to cause the grain to be fed out of the Dryer almost constantly.

If for some reason you want to disengage the ratchet pawls - for instance, at the beginning or ending of a run, to hold the grain in the Dryer a longer period of time, put the 3-way switch in the "off" position (See Instructions No. 4 and No. 11). The ratchet pawls will be disengaged and no grain will be fed out of the Dryer.

- 16. If you have followed the instructions carefully, your Dryer will operate CONTINUOUSLY without watching or adjusting as long as you keep it running and full of grain. "NO BABY SITTER NEEDED."

If you have Trouble - here are things to look for -

<u>Problem</u>	<u>Solution</u>
1. Cannot Light Pilot	1.(a) - Broken wire from transformer to spark plug. (b) - Too much gap between spark plug wire and pilot tip. (Short circuit elsewhere). Set gap at 3/16" (c) Electric power is not turned on. (d) Air Pressure switch is not functioning.

<u>Part No.</u>	<u>Description</u>
4605	LP Gas Tank Valve (Excess Flow)
4610*	Main Solenoid Valve
4611	Main Solenoid Valve Coil for Part 4610
4612*	Pilot Gas Pressure Regulator
4613	Main Solenoid Spare Parts Kit (core and piston assembly) For Part #4610
4614	Main Solenoid Valve Spring for Part #4610
4615	Pilot Hand Valve
4616*	Main Solenoid Lower Spring Guide for Part #4610
4617*	Main Solenoid Valve Gasket For Part #4610
4618*	Main Solenoid Valve for L.P. - 1963 Models and later.
4619*	Main Solenoid Valve for Natural Gas - 1963 Models and later.
4620	Main Hand Valve
4621*	Main Modulating Valve L.P. - 1963 models and later.
4622*	Main Modulating Valve for Natural Gas - 1963 models and later.
4625	Pressure Relief Valve
4630	Pressure Relief Valve Adapter
4635	Liquid Line Hand Shut-Off Valve

ELECTRICAL PARTS

4005	Air Pressure Switch
4006	Diaphragm for part #4005

*Give Serial # of Dryer when ordering these parts

M-C GRAIN DRYERS
Parts List

<u>Part No.</u>	<u>Description</u>	<u>GAS LINE PARTS</u>	<u>Problem</u>	<u>Solution</u>
			1. Cont'd.	(e) Push reset button on high limit control.
39	Main Burner Orifice Assembly for Natural Gas. Same all Models. Includes orifice and piping back to control cabinet.			(f) Orifice in pilot is plugged. Remove and clean.
40	Main Burner Orifice Assembly. Models 400 & 600 Includes orifice and piping back to control cabinet.			(g) Check pilot solenoid valve to be sure it is opening up. Coil may be burned out.
41	Main Burner Orifice Assembly. Model 300. Includes orifice and piping back to control cabinet.		2. Air pressure switch not functioning	2. (a) Dryer must be full of grain to operate. If Dryer runs out of grain, the air will escape freely and loss of air pressure causes air pressure switch to open circuit.
45	Pilot Burner Orifice Assembly. Includes orifice and piping back to control cabinet.			(b) Air tube from pressure switch into Dryer may be filled with chaff.
209	Vaporizer Ring Weldment			
210	Main Burner Ring			
650	Pilot Cup (Pilot Burner)			
655	Pilot Burner Assembly			
656	Pilot Orifice #60 hole		3. Main Burner will not light.	2. (a) Thermocouple from pilot control is not getting hot enough. Adjust pilot safety control bulb into flame enough to heat bulb sufficiently to establish contact, or regulate pressure in pilot pressure regulator.
657	Pilot Orifice for Natural Gas #56 hole			(b) You do not have enough gas flow from tank. Check, make sure all valves from tank are full open. When burner is operating, pressure gauge will indicate flow of gas.
2509	Main Burner Orifice for #300, 3/16 dia. hole			
2512	Main Burner Orifice for L.P., 1/4 dia. hole models 400, 600, 800.			
2513	Main Burner Orifice for Natural Gas, 3/8 dia. hole same all models.			
4215	Gas Pressure Dial Gauge (Main Gas Line)			
4230	Flexible LP Gas Line Inlet Hose 5/8 ID x 8" Lg.			
4435	Pressure Regulator		4. Heat shuts off	4. (a) Dryer has run low of grain
4445	Pilot Solenoid			(b) Modulating valve may be faulty.
4446	Pilot Solenoid Coil			

<u>Problem</u>	<u>Solution</u>
4. Cont'd.	(c) High limit control may have cut out. (d) Solenoid may be faulty.
5. Not enough heat.	5. (a) Valves from tank are not full open. (b) Increase pressure at pressure regulator. (This is set at factory, however, to increase gas flow, adjust screw at side of pressure regulator.) (c) Orifice in main burner partially plugged. Remove and clean.
6. Main valve sticks.	6. (a) Remove top portion of valve and polish piston.
7. Gas lines frosting up.	7. (a) When first starting burner, open the main hand valve only partially until the unit becomes warmed.
8. Lights do not work.	8. (a) No electricity. Light bulbs burned out. Replace.
9. Electric circuit out of order.	9. (a) Check circuit with wiring diagram furnished with instructions.
10. Automatic Moisture Control does not work.	10. (a) Solenoid is burned out or a wire is broken. Check and make replacement. In the meantime OPERATE DRYER MANUALLY.

WIRING DIAGRAM NO. 98062
LEVEL SWITCH & LEVEL AUGER
(SPECIAL FOR 220 VOLTS)
M-C GRAIN DRYERS

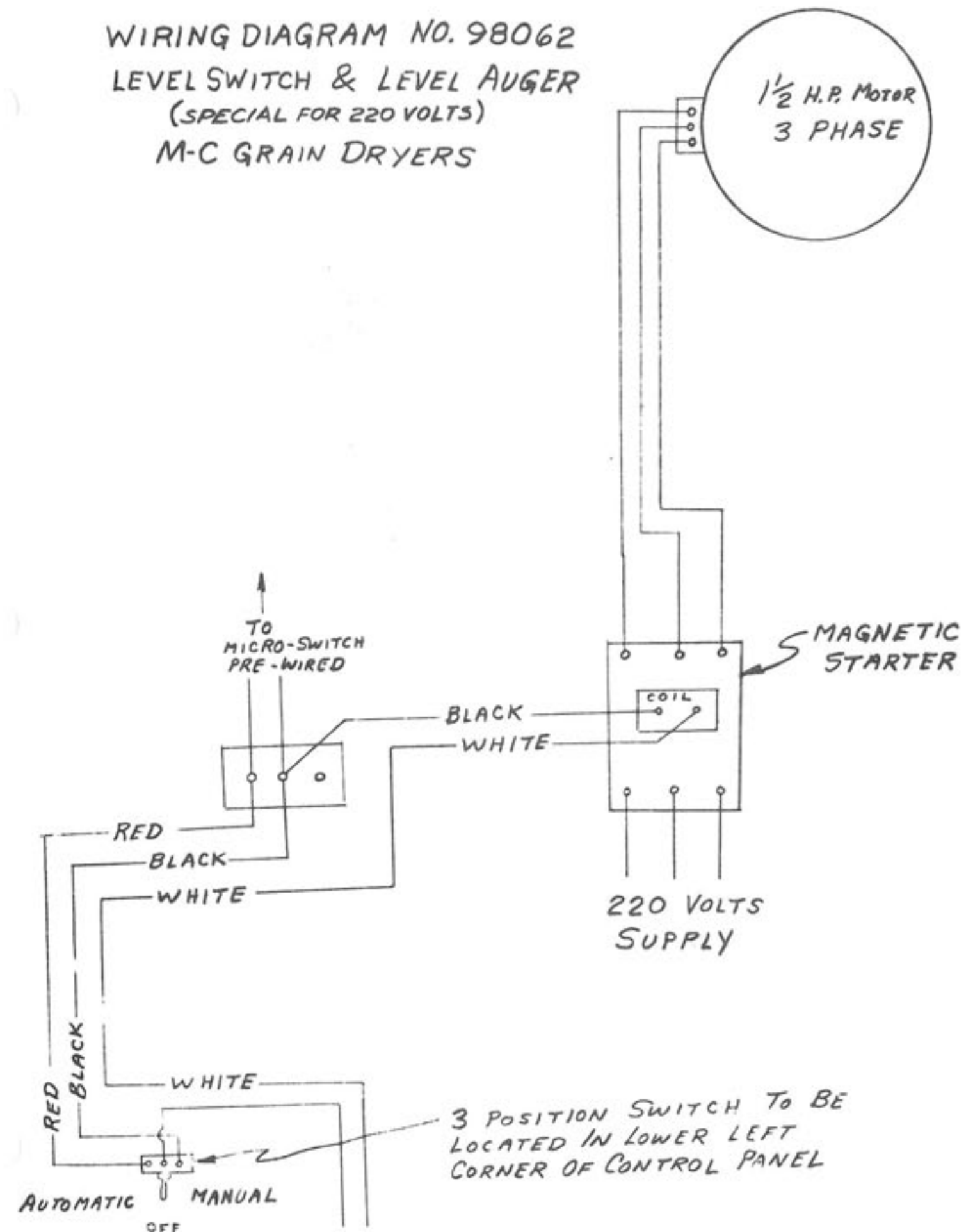

INSTRUCTIONS FOR ORDERING PARTS

1. ALL PARTS MUST BE ORDERED FROM YOUR DEALER.
2. GIVE MODEL NAME, NUMBER and SERIAL NUMBER that is stamped on the NAME PLATE of your machine.
3. Order from your PARTS LIST as this is the ONLY means we have of identifying the parts you need. Order by the QUANTITY DESIRED, the PART NUMBER and the DESCRIPTION OF PART.

Note: The Mathews Company reserves the right to incorporate any changes in design without obligation to make these changes on units previously sold.

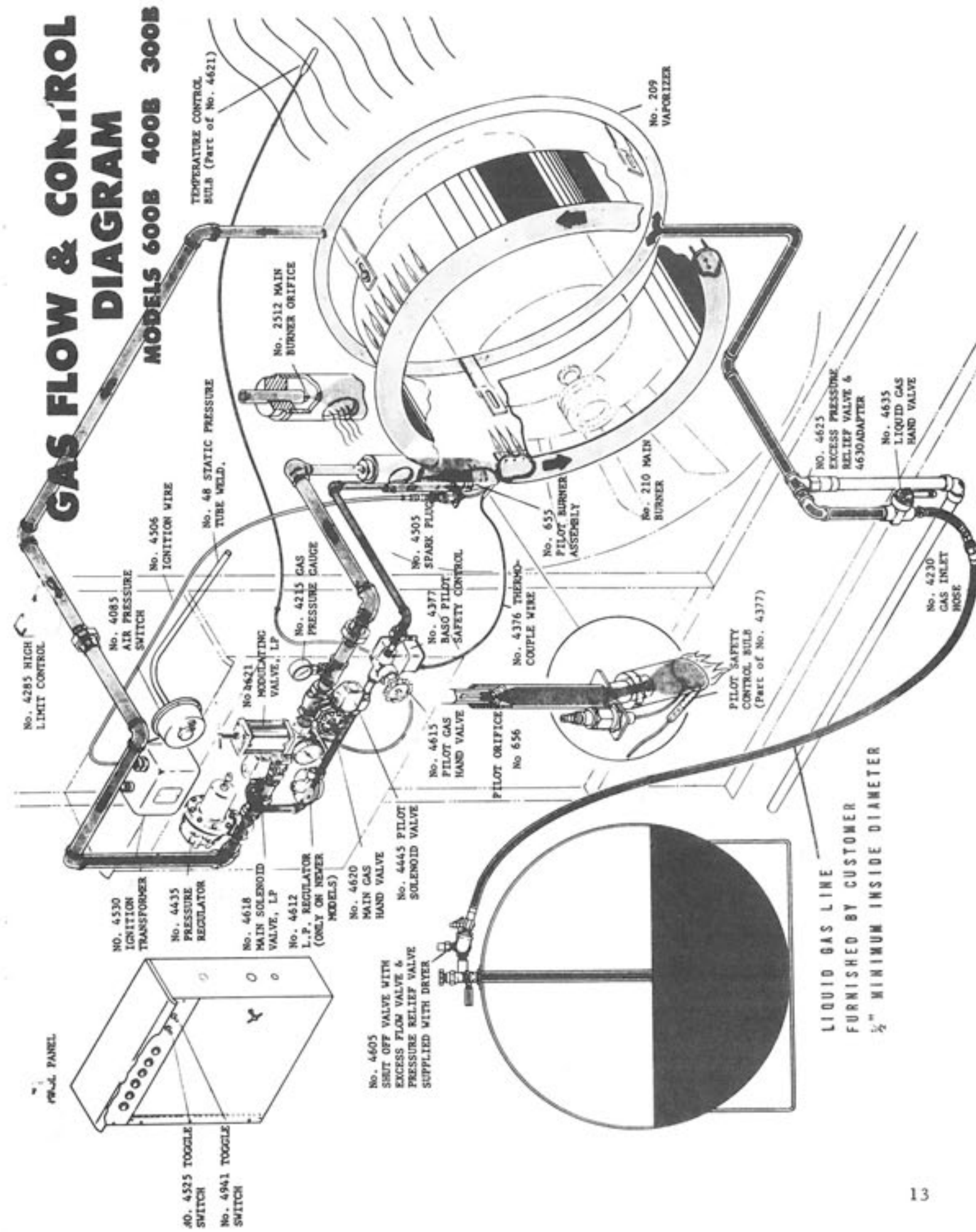

GAS FLOW & CONTROL DIAGRAM

MODELS 600B 400B 300B
800B

FOR NATURAL GAS OPERATION

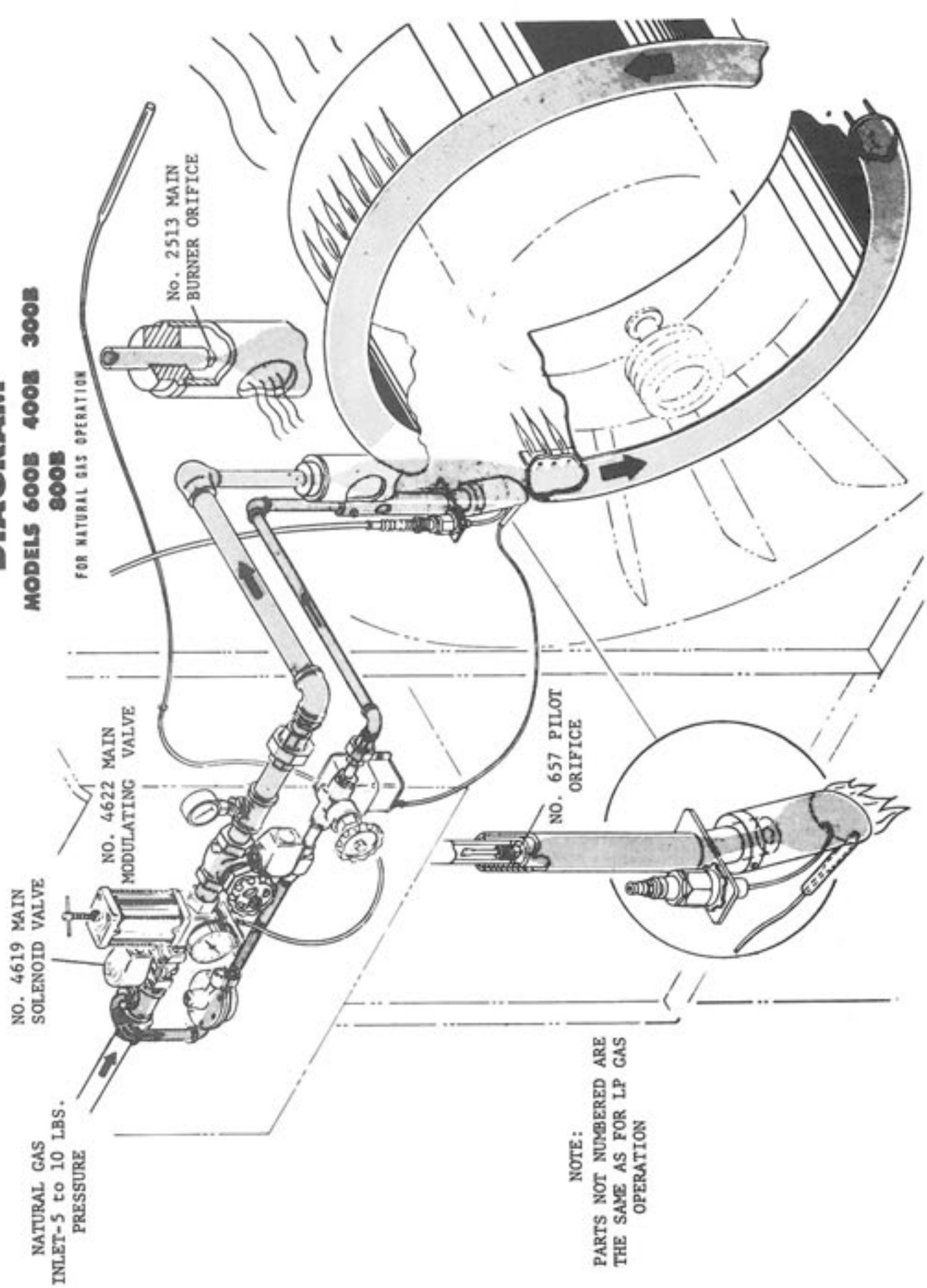

NOTE:
PARTS NOT NUMBERED ARE
THE SAME AS FOR LP GAS
OPERATION

WIRING DIAGRAM NO. 60061 FOR M-C GRAIN DRYER WITH ELEVATOR ALARM SYSTEM-MODEL 600 B-E-L

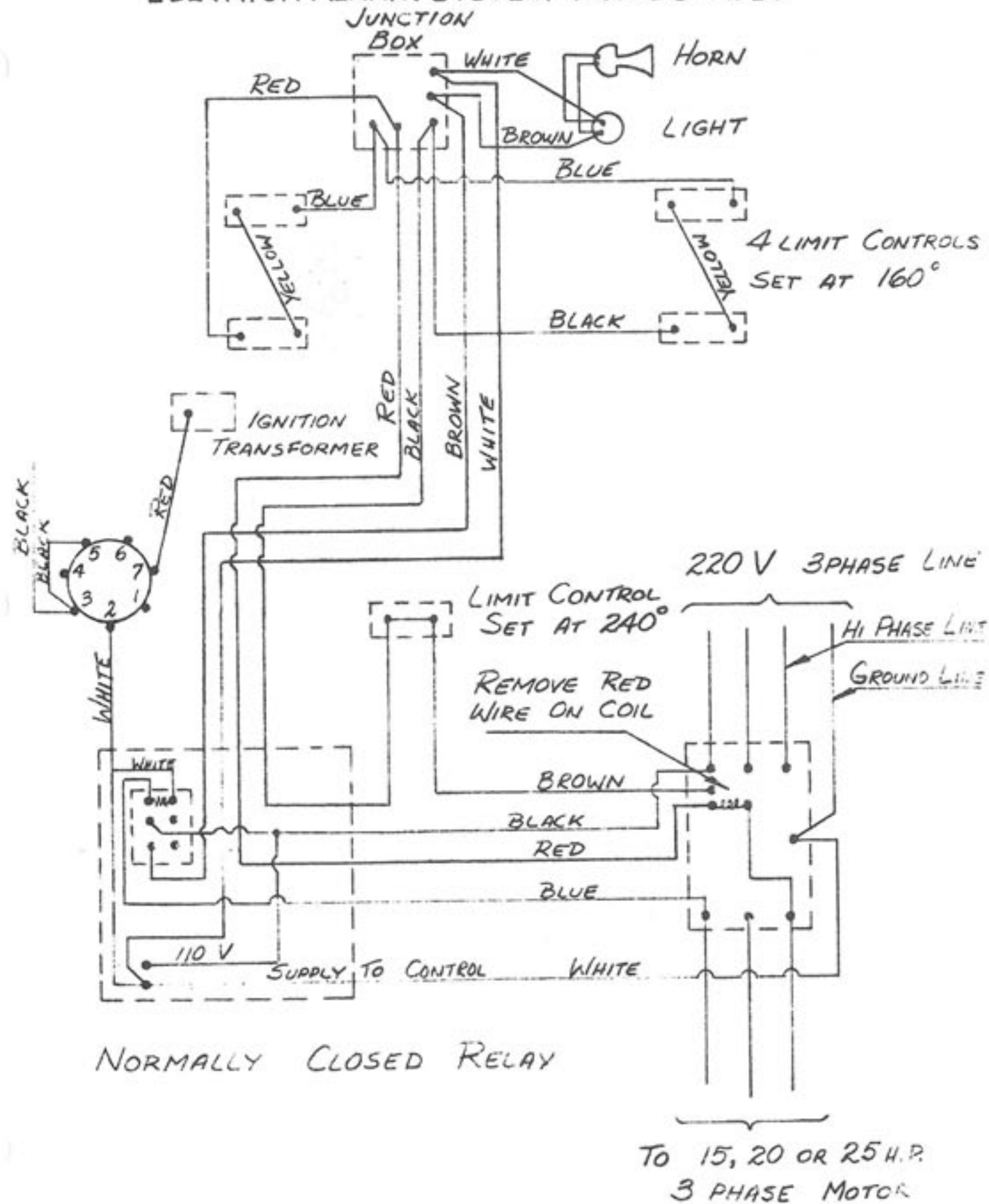

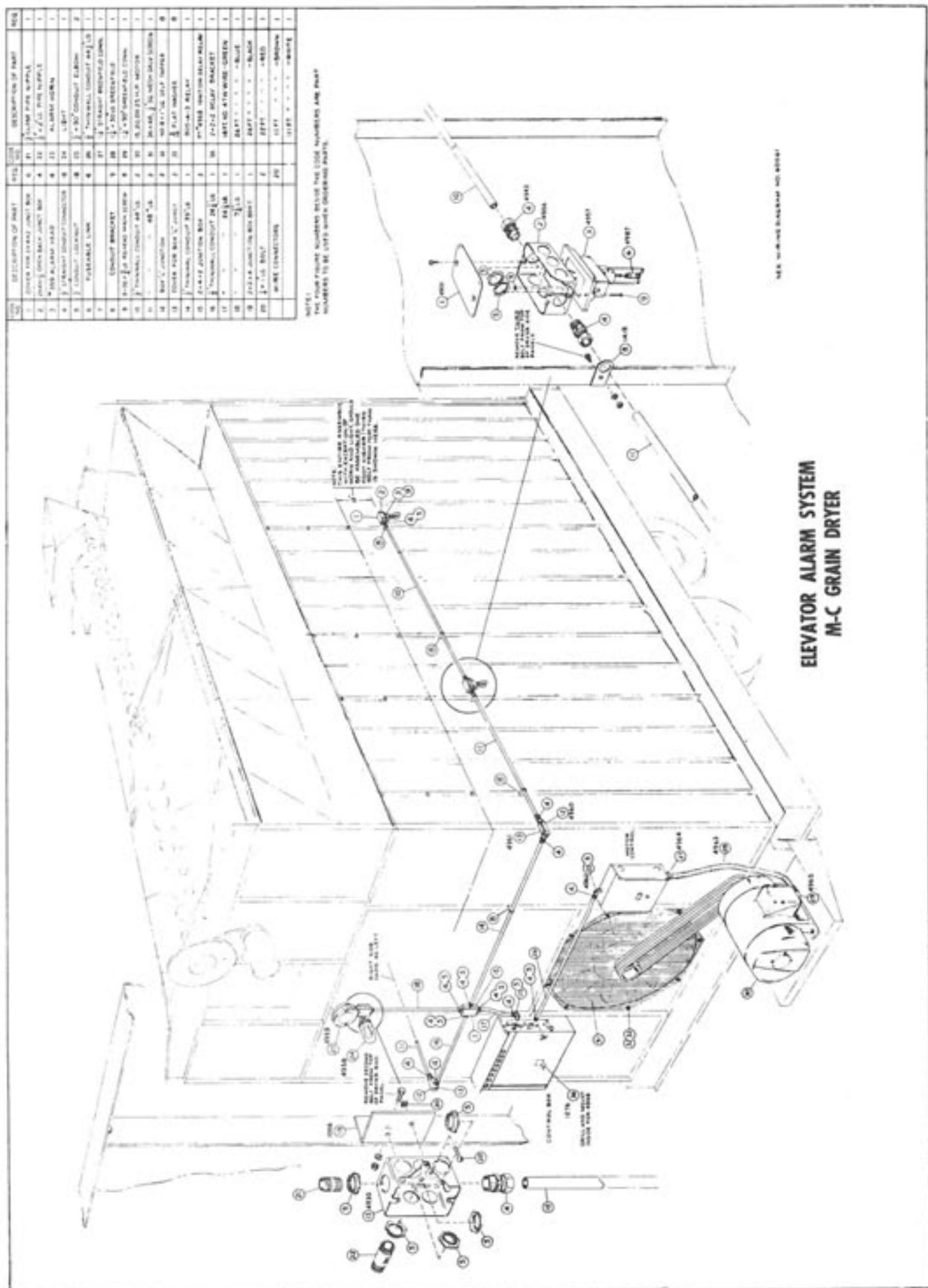

INSTRUCTIONS FOR CHANGING OVER FROM LP GAS TO NATURAL GAS OPERATION

For natural gas operation the Models 300, 400, 600 and 800 Grain Dryers require 5 to 10 lbs. of gas pressure.

1. Remove the pressure regulator (No. 4435 on Gas Flow Diagram) and connect natural gas line to pipe leading to main solenoid valve. If more than 10 lbs. of Gas Pressure are available, do not remove No. 4435 pressure regulator.
2. Remove main burner orifice (1/4" pipe plug) and enlarge hole in plug with 3/8" drill. In cold weather it may be advisable to remove orifice.
3. Test run Dryer to see if enough heat is available. If Light No.4 on control panel fails to light, you will have to remove pilot orifice (brass pipe plug with copper tube) and enlarge hole in plug with No. 56 drill. Dryer will now operate providing you have a minimum of 5 lbs operating gas pressure.
4. Be sure to clean out all metal chips after drilling.

LUBRICATION

All bearings on the grain augers are pre-lubricated and require no further attention. The bearings on the fan shaft of the Dryers should be lubricated with regular gun grease every 100 hours of operation. On the Series 400, 600 and 800 there are universal joint drive shafts connecting the hot air fan and cool air fan. These are reached by opening the trap door to the cooling chamber (PTO should be greased daily). Do not over-grease. One or two shots are sufficient. Excess greasing blows out seals. All other parts - ratchets, ratchet drive, chain and variable speed drive - should be oiled with No. 10 oil. When you stop using Dryer, grease and oil all parts.

Care should be taken to avoid getting oil into the ratchet pawl solenoids.

Be sure to keep the hand wheel shaft on your variable drive pulleys well lubricated. Lack of lubrication may result in the rusting of the shaft sleeve and may break the hand wheel if forced. If the pulley shaft is not lubricated, the pulleys may stick making adjustment to the correct speed difficult.

WIRING DIAGRAM NO. 98061A-MODELS 400BE-600BE

WITH ELECTRIC MOTOR DRIVE AND LEVEL AUGER

M-C GRAIN DRYERS

These parts should be disassembled, cleaned and oiled and reassembled if the machine is to remain idle for any length of time. During operation, particularly during rainy weather, make sure the hand wheel shaft and pulley shaft are lubricated with No. 10 lubricating oil. When the machine is put away, it would be wise to wrap or cover the variable drive assembly to keep water out of the parts.

Belt Tension

After the first hour or two of operation, check drive belts and tighten. This adjustment should last a fairly long time.

Cleaning

The M-C Continuous Grain Dryers usually will run very clean. The chaff and cracked grain have a tendency to be forced out by the air pressure of the fans. However, there are access doors to the heat chamber and to the cooling chamber. When you grease the unit, check for accumulation of chaff and broken grain and sweep them out of Dryer at this time. In the cooling section, the chaff is blown down to the far end. There are clean-out doors on each side of the hot air fan at the drive end of the machine. Open these doors and clean chaff out at this point. Some grease will accumulate on the fans, so wipe the fans off occasionally. Grease and dirt accumulate on the fan hub and the blades causing the fans to get out of balance. By cleaning your machine and lubricating it, as suggested above, you will get long trouble-free service.

MATHEWS COMPANY
Crystal Lake, Illinois
August 1964

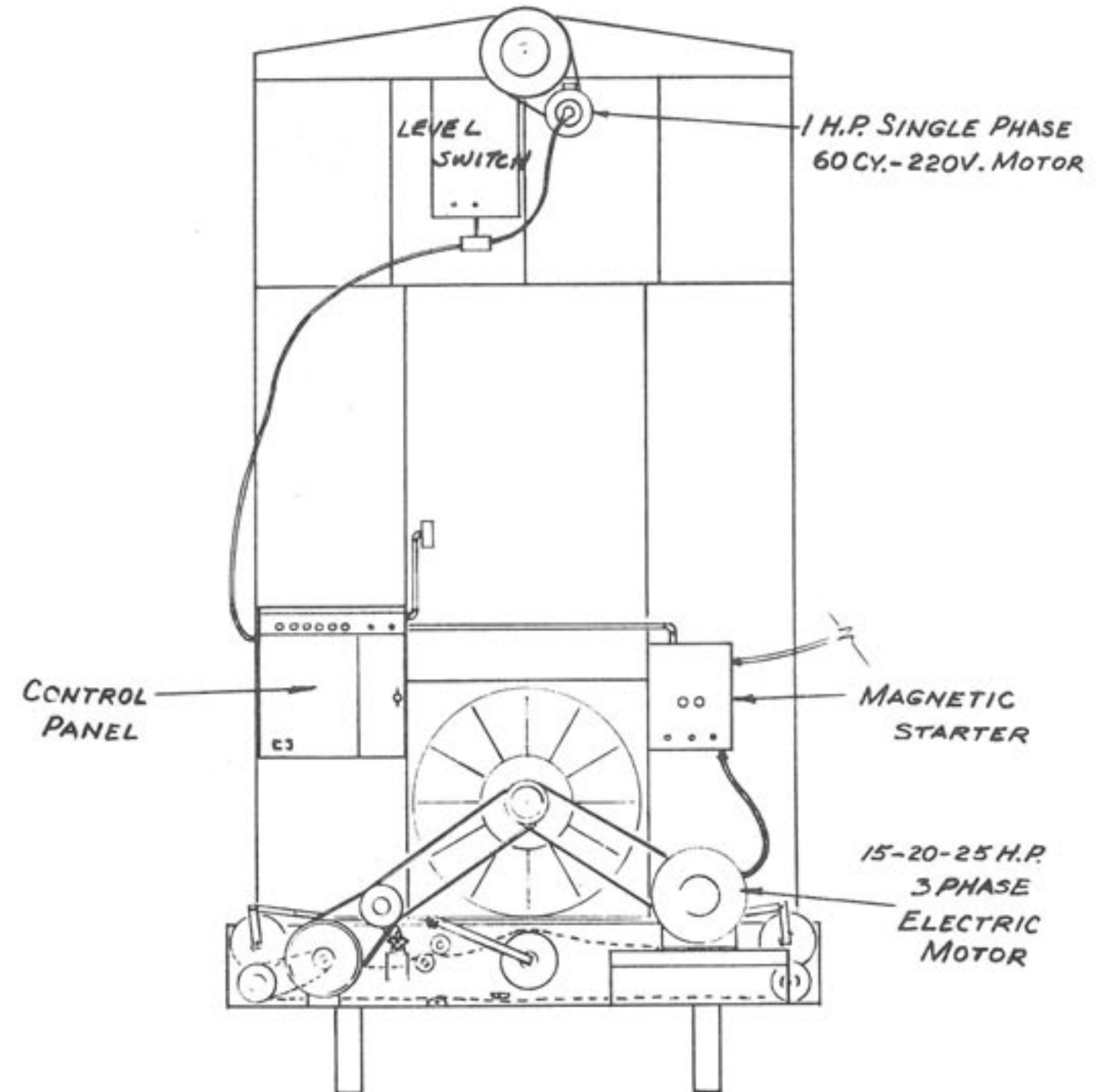

ASSEMBLY INSTRUCTIONS FOR WET HOLDING HOPPER
(See Illustration)

- Step No. 1 - Assemble the four rear end hopper panels together by bolting through the holes provided in the panel flanges. Note the location of #920 ladder panel.
- 2 - Assemble the four front end hopper panels together as in Step #1. Note the location of #982 level switch panel assembly, if level auger is to be used.
- 3 - Position the panels you assembled in Steps #1 and #2 on top of Dryer. Align the hinge brackets on the backs of panels with those on top inside edge of ends of Dryer.
- 4 - Insert the two #1835 hinge rods through the hinge brackets and cotter pin both ends.
- 5 - Raise end panels into a vertical position.
- 6 - Place one of the hopper side panels against the inside of the hopper end panels lining the five holes in the end panels with those in the flange of the side panel. This will place hopper side panel in correct angled position.
- 7 - Bolt another hopper side panel to the side of the one you assembled in Step #6. Place braces #1061 and #925 in line with the bottom and top holes before inserting bolts through these holes.
- 8 - Bolt other end of braces to top edge of Dryer side wall.
- 9 - There will be four hopper side panels on each side of Model 300 Dryers, six on each side of Model 400 Dryers, and eight on each side of Models 600 and 800. Repeat Steps #6, #7, and #8 on both sides of Dryer until all hopper side panels have been assembled to the Dryer.
- 10 - Fasten extension angles to bottom flanges of side hopper panels by bolting through holes provided. For Models 400 and 600 use 1080 splice angle where the extension angles butt together as shown in illustration.
- 11 - Bolt hopper panel stiffener bars to top flanges of side hopper panels and end hopper panels. Use splice angle #1080 where side stiffeners butt together on Model 600 and 800.
- 12 - Fasten short section of ladder to ladder panel at rear of machine. Use #2420 spacer and flat washers between panel and ladder.

WIRING DIAGRAM NO. 40561 FOR
MODELS 300B-400B-600B-800B
M-C GRAIN DRYER

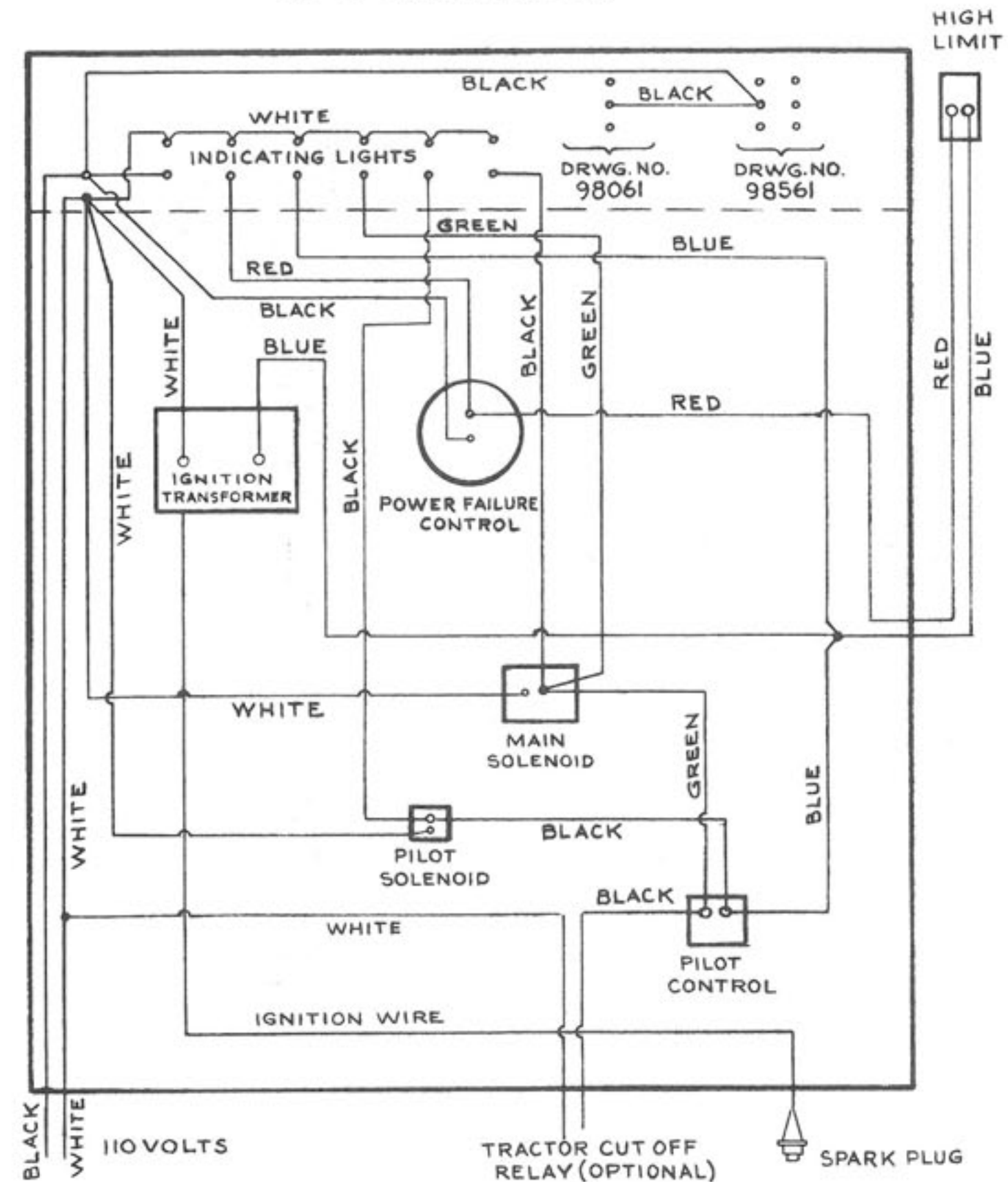

M-C AUTOMATIC MOISTURE CONTROL

WIRING DIAGRAM

NO. 98561

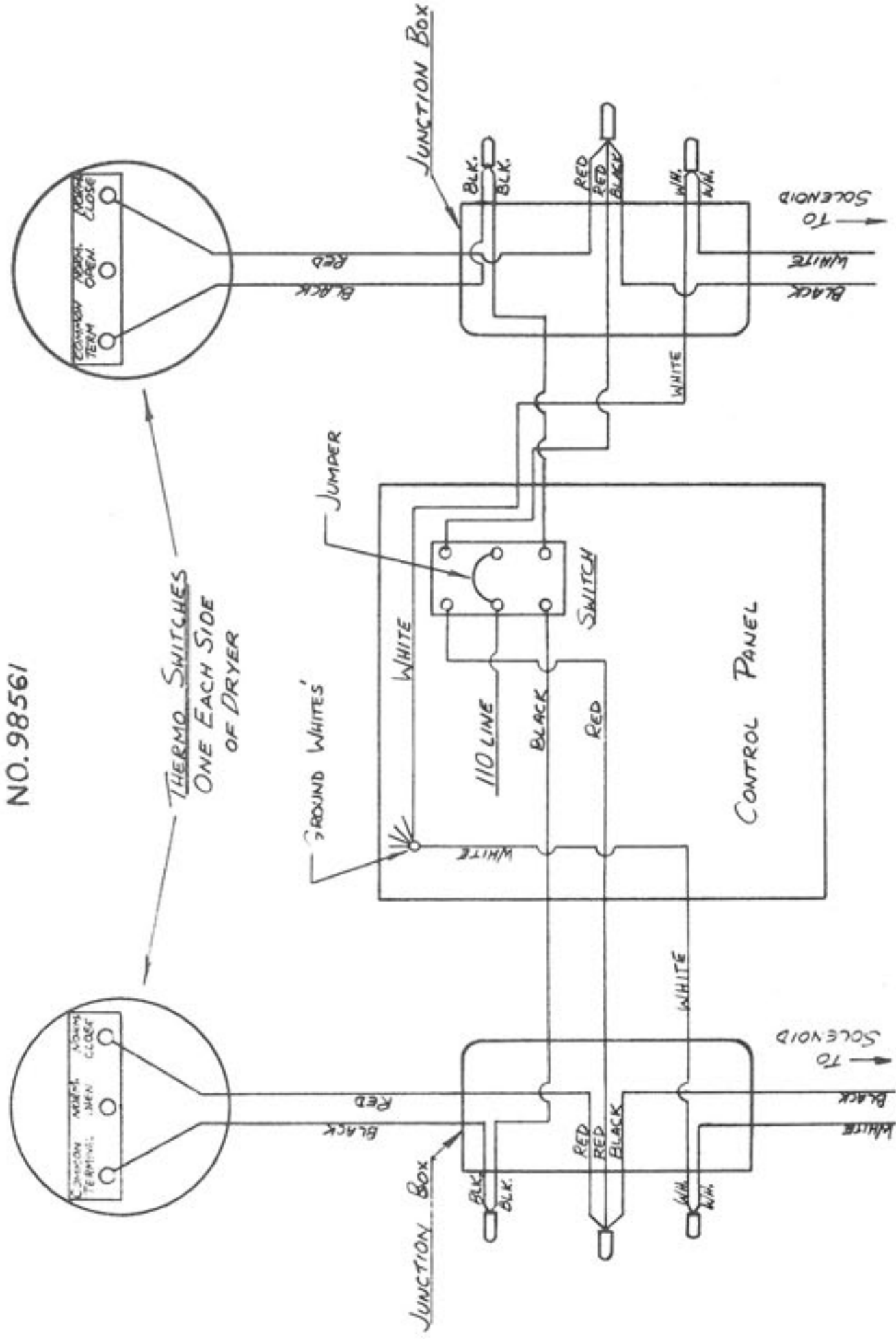

THERMOSWITCH RED WIRE WAS NORMALLY OPEN

WET HOLDING HOPPER ASSEMBLY FOR M-C GRAIN DRYERS

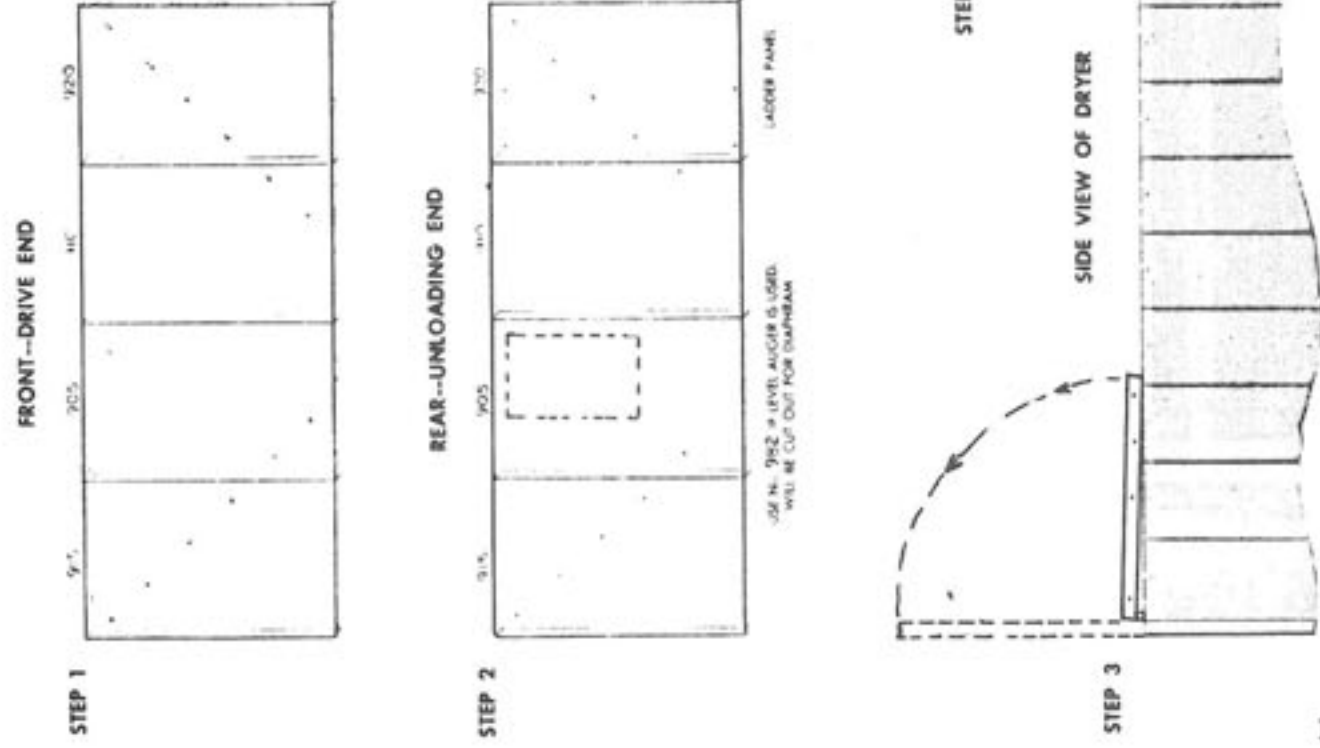

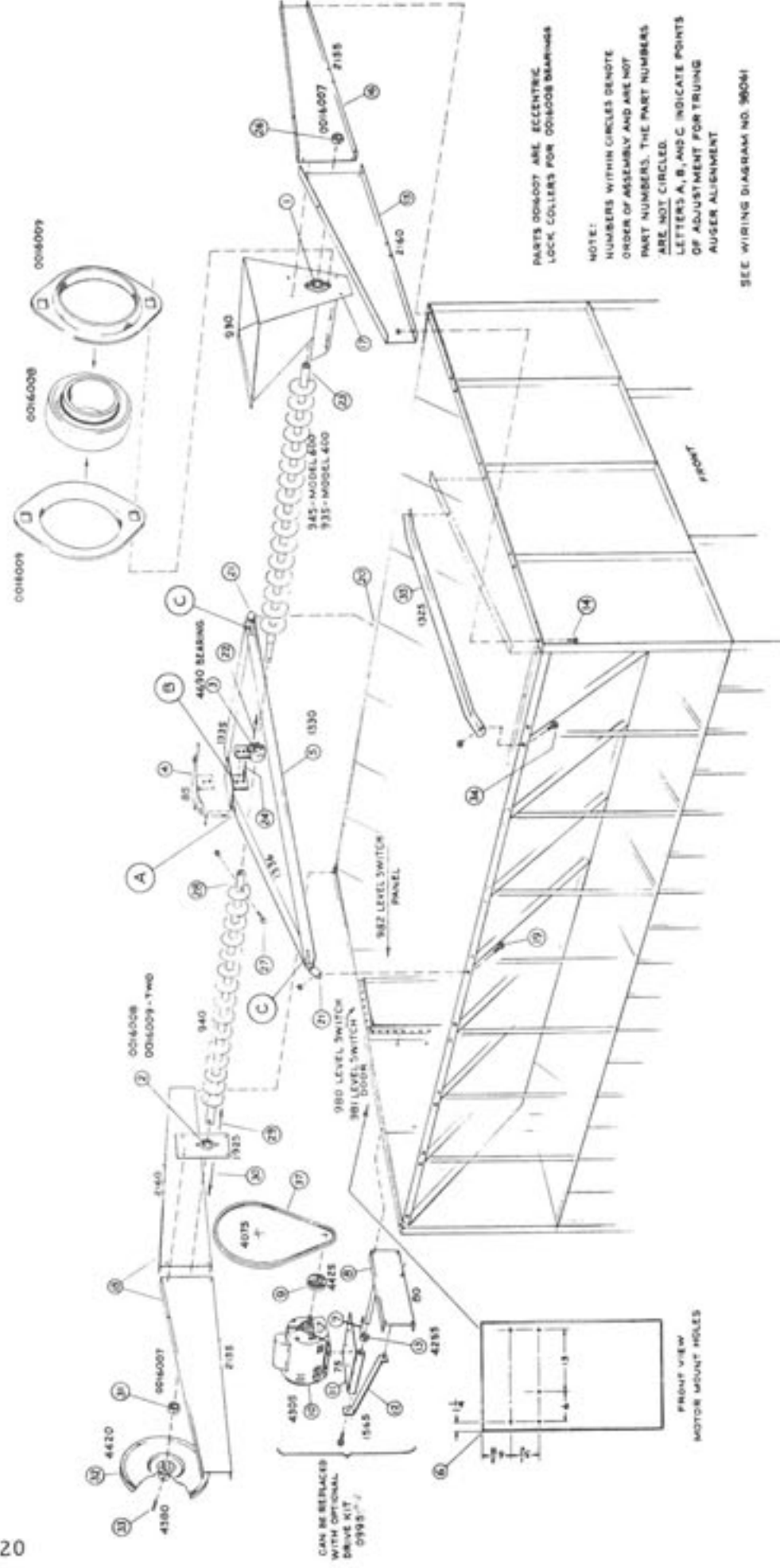

**LEVELING AUGER ASSEMBLY
M-C GRAIN DRYER**

COMP NO.	DESCRIPTION	PART NO.	REQ.
1	1/2" CONDUIT ELBOW *BSS	4427	2
2	1/2" CONDUIT JOINT *BSS	4427	2
3	1/2" CONDUIT *BSS	4427	2
4	1/2" CONDUIT *BSS	4427	2
5	1/2" CONDUIT *BSS	4427	2
6	1/2" CONDUIT *BSS	4427	2
7	1/2" CONDUIT *BSS	4427	2
8	1/2" CONDUIT *BSS	4427	2
9	1/2" CONDUIT *BSS	4427	2
10	1/2" CONDUIT *BSS	4427	2
11	1/2" CONDUIT *BSS	4427	2
12	1/2" CONDUIT *BSS	4427	2
13	1/2" CONDUIT *BSS	4427	2
14	1/2" CONDUIT *BSS	4427	2
15	1/2" CONDUIT *BSS	4427	2
16	1/2" CONDUIT *BSS	4427	2
17	1/2" CONDUIT *BSS	4427	2
18	1/2" CONDUIT *BSS	4427	2
19	1/2" CONDUIT *BSS	4427	2
20	1/2" CONDUIT *BSS	4427	2

(1-20) WELD JUNCTION BOX SEE WIRING DIAGRAM.

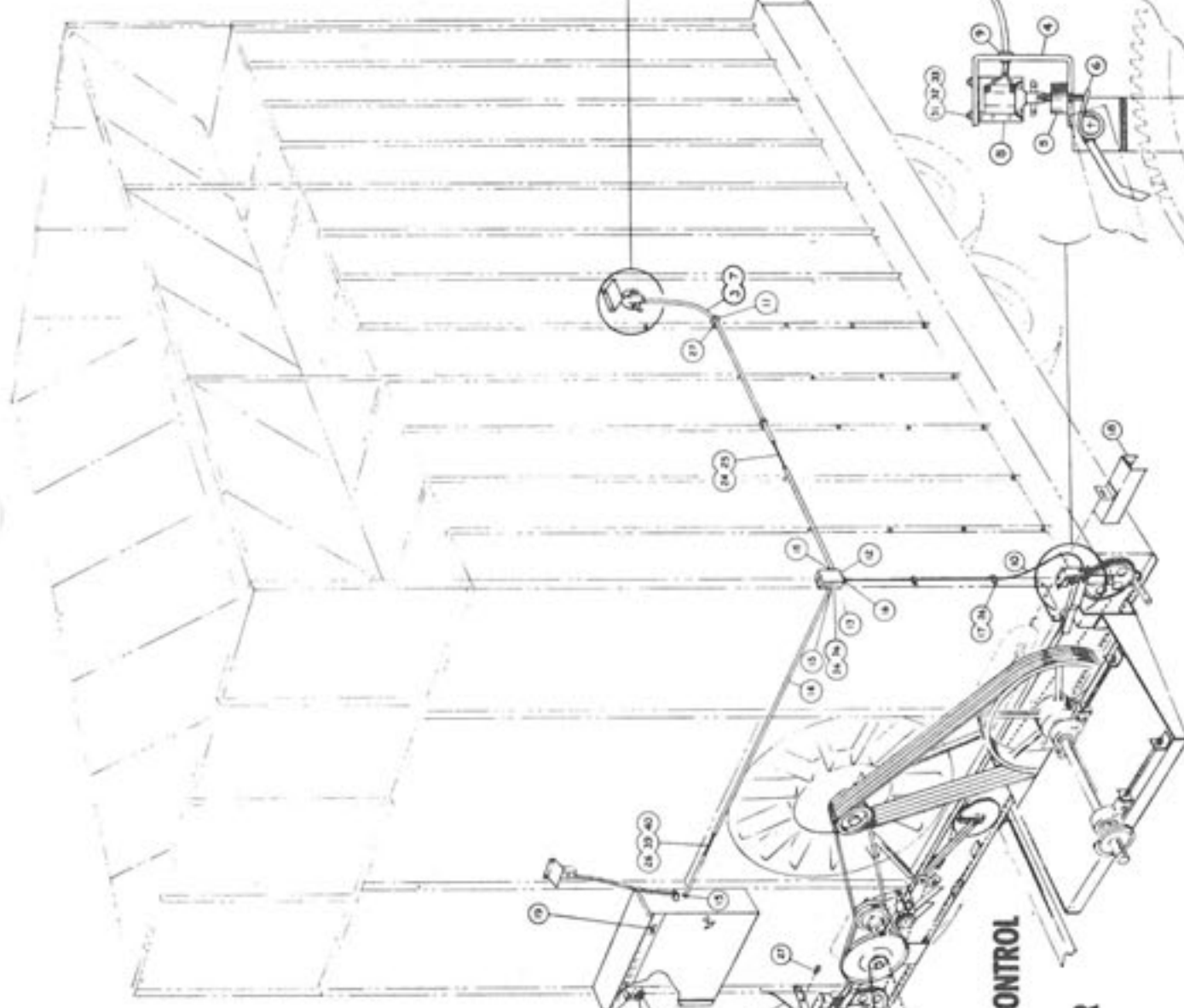

**AUTOMATIC MOISTURE CONTROL
ASSEMBLY
M-C GRAIN DRYER**

CODE NO.	DESCRIPTION	PART NO.	REQ.
1	PROTECTOR HOOD	4427	2
2	THEMISTATION	4427	2
3	CONDUIT *BSS	4427	2
4	CONDUIT *BSS	4427	2
5	CONDUIT *BSS	4427	2
6	CONDUIT *BSS	4427	2
7	CONDUIT *BSS	4427	2
8	CONDUIT *BSS	4427	2
9	CONDUIT *BSS	4427	2
10	CONDUIT *BSS	4427	2
11	CONDUIT *BSS	4427	2
12	CONDUIT *BSS	4427	2
13	CONDUIT *BSS	4427	2
14	CONDUIT *BSS	4427	2
15	CONDUIT *BSS	4427	2
16	CONDUIT *BSS	4427	2
17	CONDUIT *BSS	4427	2
18	CONDUIT *BSS	4427	2
19	CONDUIT *BSS	4427	2
20	CONDUIT *BSS	4427	2

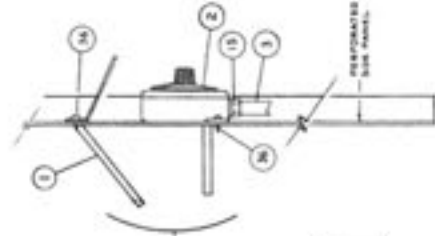

SEE WIRING DIAGRAM NO. 96041

1/2 x 1/4 - 1/2"

LEVELING AUGER ASSEMBLY

(Points A, B and C are final adjustment points and you should not concern yourself with these points until instructed to do so.)

The parts for the leveling auger have been numbered on the illustration in the order that they should be assembled. For example, part number one should be assembled first; part number two, second and so on. Following this order of assembly will enable you to get the leveling auger assembled to the dryer faster and more easily.

Follow the written instructions and the illustration closely. Read through each step completely to make sure you understand the procedure before starting. More time can be saved if one person does steps #1 through #13 while another person starts with step #14 and works through #15, #16, #17 and so on.

- Step #1 - Place one of the bearings between two of the bearing flanges and bolt to the rear of the auger hopper as shown. Be sure the side of the bearing with the inner race protruding is facing outside of the hopper.
- Step #2 - Follow the same procedure as Step #1 to bolt a bearing to the front bearing mounting plate. Be sure that the side of the bearing with the inner race protruding is facing away from the mounting plate when you bolt the flanges to the plate.
- Step #3 - Press the third and last bearing into the center bearing bracket. The bearing will have to be started into the bracket edgewise and then pressed flat. Do not bolt bracket to center bearing mount at this time.
- Step #4 - Bolt center bearing mount to top of right and left center bearing braces as shown at "A".
- Step #5 - Bolt center bearing cross tie brace to center bearing braces. There are three holes in each end of the cross tie brace. Use the hole nearest the end.
- Step #6 - Drill five 3/8 dia. holes in dryer front end panel. A front view of panel is shown for location of holes. Be sure you locate holes from in front of the dryer.
- Step #7 - Slide 1" lock collar on to shaft of motor mount bracket. Do not tighten lock collar set screw at this time. This lock collar is not an eccentric lock collar. It is flat on both sides. Be sure you have the right

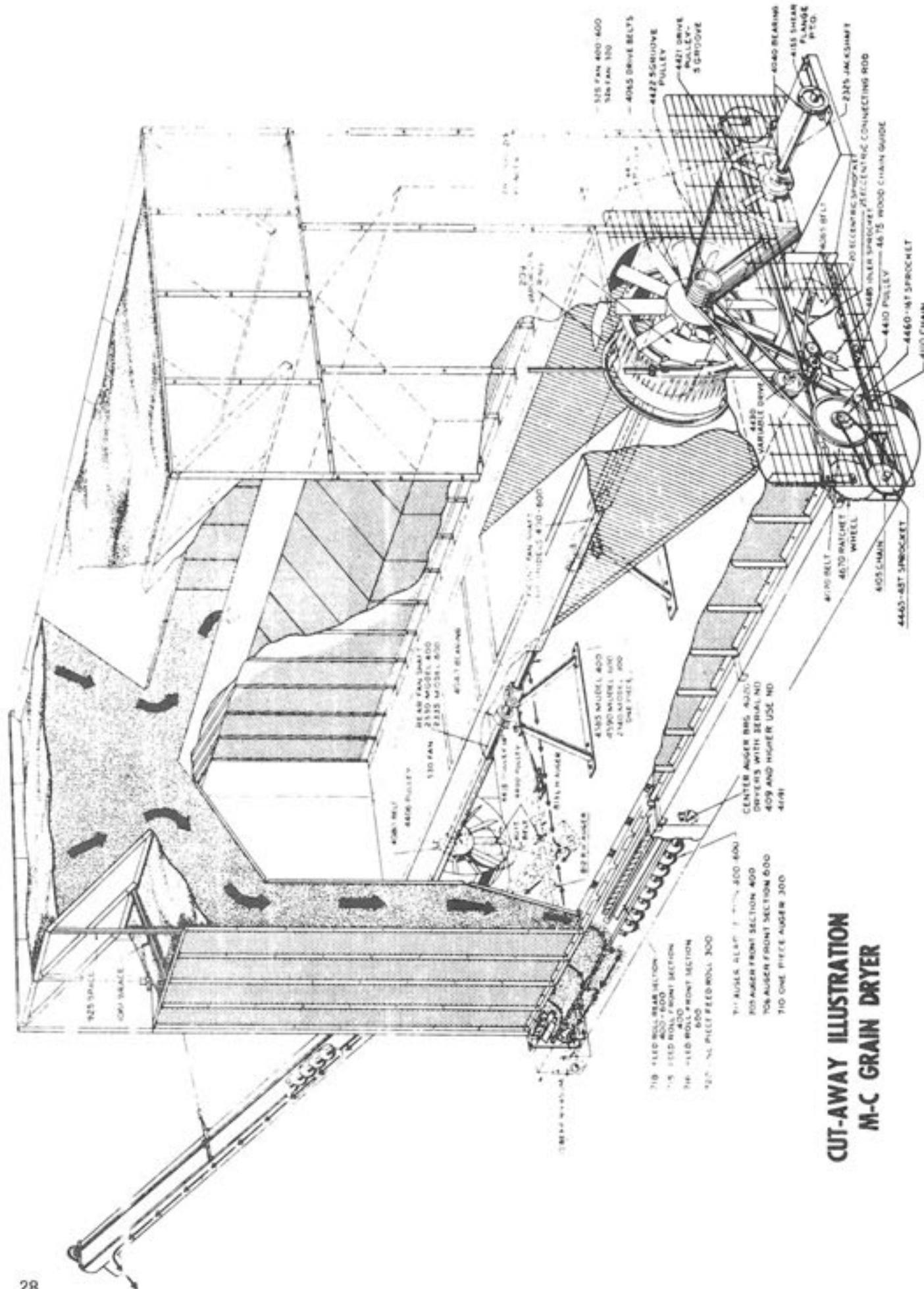

**CUT-AWAY ILLUSTRATION
M-C GRAIN DRYER**

one as you will need the other three eccentric lock collars elsewhere.

- Step #8 - Bolt motor mounting bracket to dryer.
- Step #9 - Slide small pulley onto motor shaft and secure in place with pulley set screw. Center hub of pulley should face towards motor.
- Step #10- Bolt motor to motor mount as shown.
- Step #11- Slide motor mount with motor attached onto shaft of motor mounting bracket. Be sure the pulley is facing the dryer.
- Step #12- Bolt one end of motor mount brace to motor mounting rod and the other end to the dryer through the motor mounting bracket.
- Step #13- Adjust lock collar to keep motor mount from sliding on shaft and secure lock collar in place with set screw.
- Step #14- Remove all eight bolts from stiffener bar across the top edge of dryer end panels and keep them handy.
- Step #15- Place left rear auger end panel in position on top of stiffener bar and fasten in place with four of the bolts you removed in step #13. Do not tighten bolts completely at this time.
- Step #16- Do the same thing with right rear auger end panel.
- Step #17 - Bolt auger hopper to auger end panels as shown.
- Step #18 -Assemble right and left front auger end panels the same as you did in Steps #14, 15, and 16.
- Step #19- Remove the eighth bolt from the front of the dryer from the stiffener bar running along the top edge of the dryer side panels and keep it handy.
- Step #20- Do the same thing with the bolt directly opposite on the other side of the dryer.

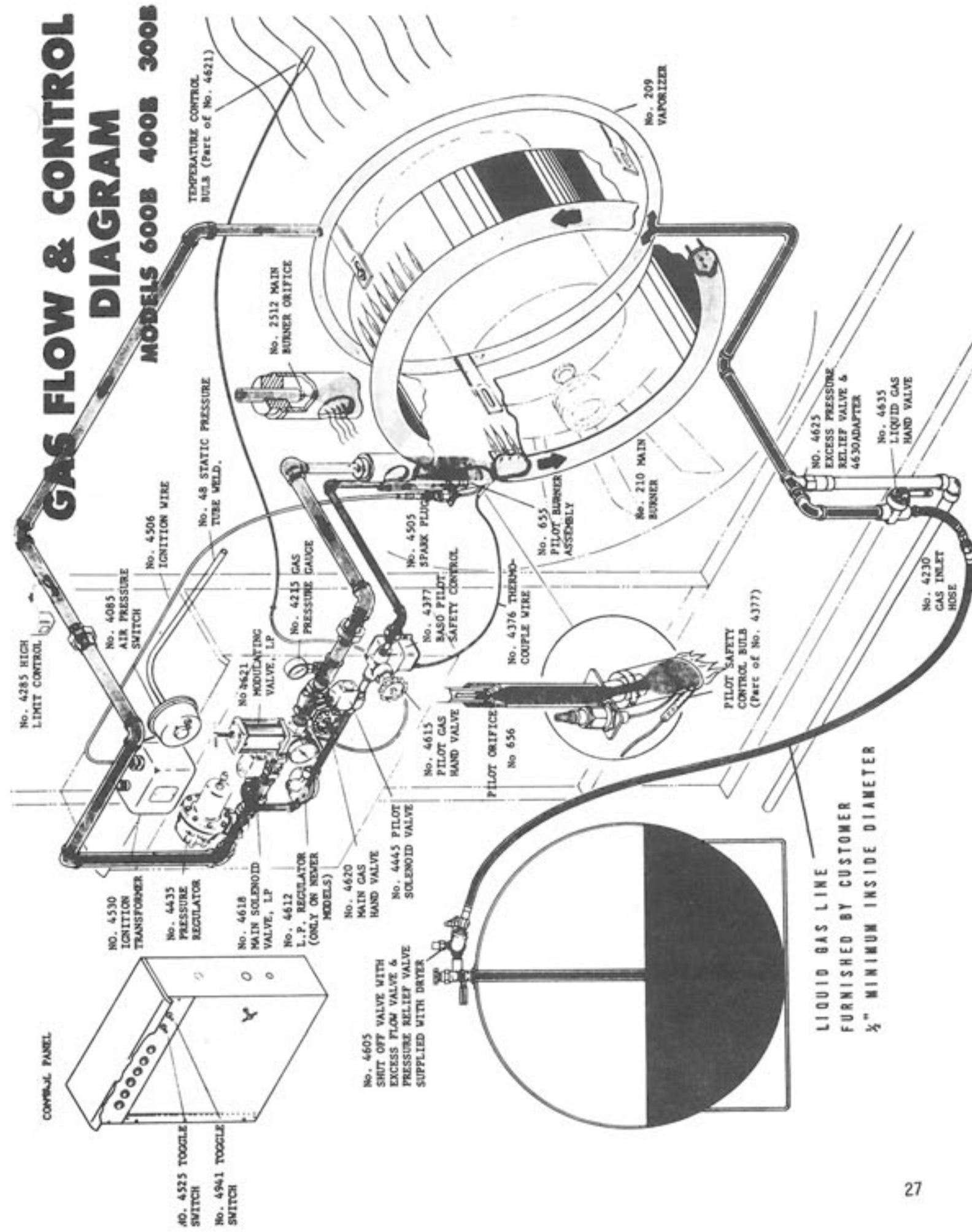

WIRING DIAGRAM NO. 98061

LEVEL SWITCH AND AUGER
M-C GRAIN DRYERS

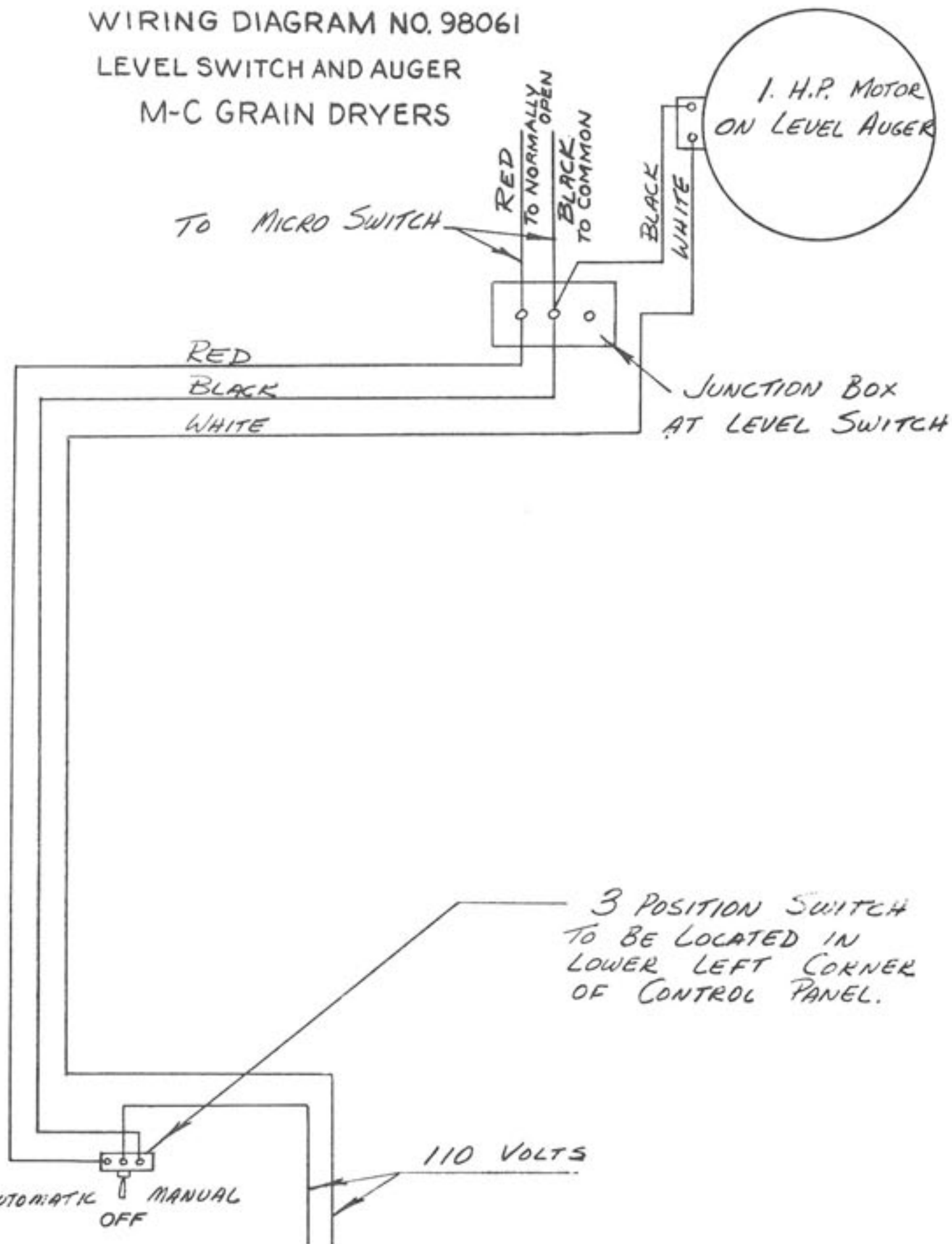

- Step #21 - Bolt the center bearing mount braces into place on top of the stiffener bars with bolts you just removed. Dryer sides may have to be pulled together somewhat to make holes line up.
- Step #22 - The leveling auger is made in two sections. The rear section has a splice rod bolted into one end of its center tube. Slip the center bearing and bracket over the splice rod and onto the center tube of the rear auger section. Be sure the side of the bearing with the inner race protruding is facing away from the auger as you slide it on the tube.
- Step #23 - Insert the other end of the rear auger section into the auger hopper so that its center tube goes through the bearing and protrudes to the rear of the dryer.
- Step #24 - Now bolt center bearing bracket to center bearing mount as shown at "B". Do not tighten these bolts completely at this time.
- Step #25 - Slide one of the eccentric lock collars over the splice rod and onto the auger center tube. Be sure that the eccentric side of the lock collar is facing towards the bearing. Do not tighten collar set screw at this time.
- Step #26 - Slide another eccentric lock collar onto the other end of the auger center tube that is protruding to the rear of the dryer. Be sure the eccentric side of the collar is facing towards the bearing. Do not tighten set screw at this time.
- Step #27 - Slide the front bearing and mount plate onto the end of the front auger section as shown. Be sure that the side of the bearing with the inner race protruding is facing away from the auger as you slide it on the tube.
- Step #28 - Remove the bolt located near the other end of the front auger section and keep it handy.
- Step #29 - Slide this end of the front auger section onto the splice rod protruding from the rear auger section. Secure in place by replacing the bolt you just removed.

Step #30 -Bolt the front bearing mounting plate to the inside of the front auger end panels.

Step #31 -Slide an eccentric lock collar onto the end of the auger tube protruding to the front of the dryer. Be sure the eccentric side of the collar is facing towards the bearing as you slide it on the tube. Do not tighten collar set screw at this time.

Step #32 -Slide large pulley onto the end of the auger tube. Be sure the center hub of the pulley is facing away from the tube as you slide it on the tube. Also try to align the hole in the auger tube with the hole in the hub of the pulley at this time.

Step #33- Secure the pulley in place by driving the roll pin provided through the hole in the pulley hub and through the auger tube.

Step #34 -Remove the third bolt from the end from the stiffener bar along the tope edge of the dryer side panels and keep it handy.

Step #35 -Bolt one end of the diagonal corner brace to the top of the end panel and the other end to the top of the stiffener bar with the bolt you just removed. Do the same thing on all four corners of the dryer.

Steps A-B-C-

Now it is time to true up the auger to make sure it is straight from end to end and will rotate freely with no binding or scraping. Rotate the auger by hand while sighting along the auger to note any misalignment it might have. Corrections can be made at points "A", "B" and "C". If the auger is out of line sideways, make corrections at point "B". If the auger is high or low at the center, make correction at point "A". If the auger cannot be aligned by making adjustments at "A" and "B", you will have to remove the cross tie brace at points "C" and bolt it into the second hole from the ends. After making change at points "C" you will have to again adjust points "A" and "B".

After you have the auger in correct alignment, tighten

all bolts at Points "A", "B", and "C" and go on to step #36.

Step #36-Tighten the three eccentric lock collars from Steps #26 and #31 onto the protruding inner races of the three bearings by tapping with a punch and hammer. A hole is provided in each collar for this purpose. Tighten the collars to the auger with the collar set screw.

Step #37- Place "V" belt around large auger pulley and small motor pulley.

Step #38- Tighten all bolts completely at this time.