

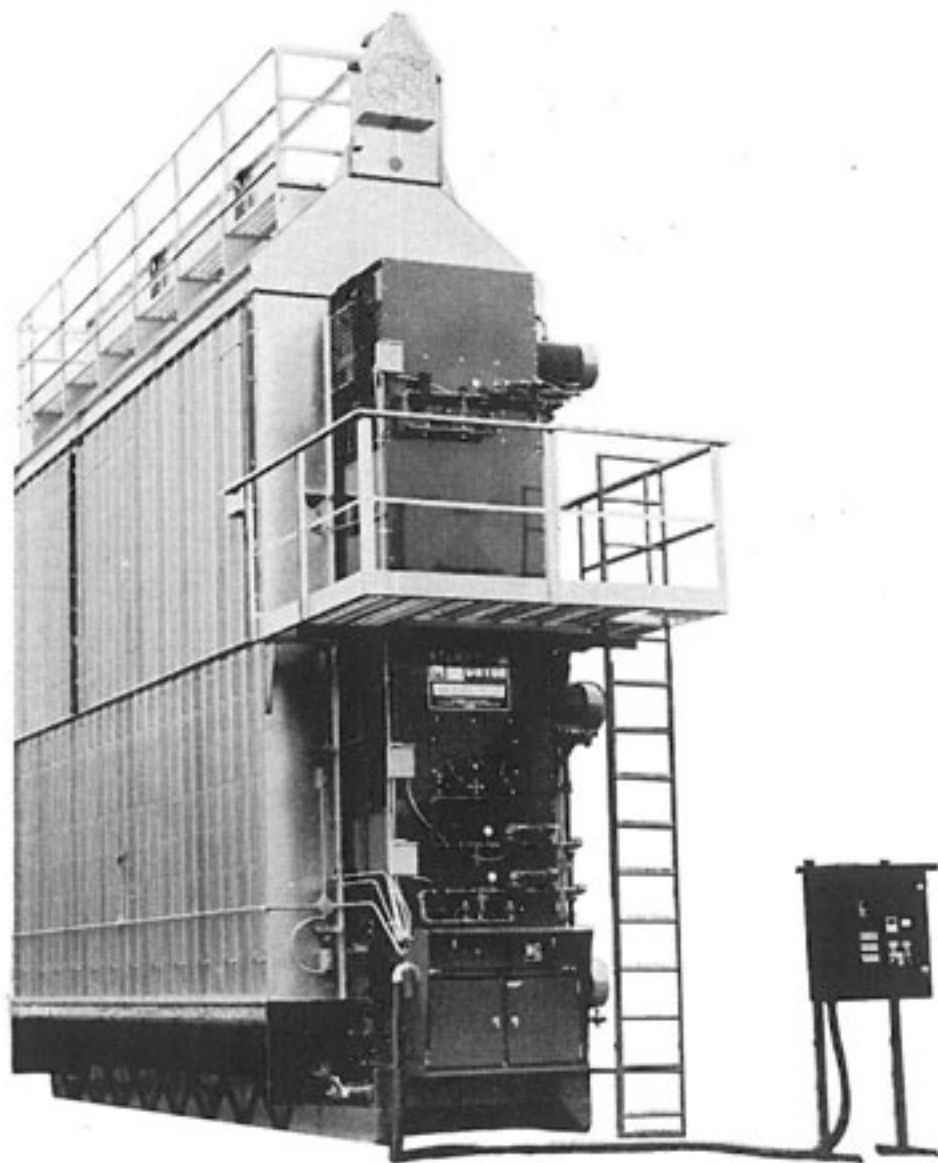

**Model 680, 780,
980, 1080 & 1180
Continuous Flow
Grain Dryers**
(Starting w/Serial No. 54495)



PARTS CATALOG

Form No. D 317, December 1995

Mathews Company/ 500 Industrial Ave., Crystal Lake, IL 60012, U.S.A.
815/459-2210 FAX 815/459-5889

CONTENTS

	Page
Introduction	
Parts Ordering Instructions	1
Model and Serial Number Location	1
Capscrew Grade Identification	1
Parts	
Air Pressure Switch	35
Augers	
Level	46
Unload	2
Belts	
Fan Drive	22
Level Auger	46
Unload Auger - SCR Drive	18
Bin Level Indicator	35
Burner	20
Cabinets	
Motor Control - Base Sections	36
Remote Cabinet	38
Remote Control	40
Transformer	36
Circuit Breakers - Level Auger, Unload Auger and Fan Motor	54-55
Coils	
Magnetic Starter - 115V	56
1 ¼" Solenoid Valve	31
½" Solenoid Valve	31
Control Panel Lights, Switches and Controls	40
Decal Kit - All Models	24
Electrical Components in 115V Control Cabinet	43
Electrode	20
End Panels	
Bottom Module	14
8' Module	16
5' Module	17
Fans and Fan Drive	
680 and 980	22
1080 and 1180	22
Fan Housing	24-27
Fire Alarm w/Safety Shut-Off Valve (Optional)	29
Flame Sensing Probe	20
Floor Panels	
Bottom Module	14
8' Module	16

Continued on next page

	Page
Guards	
Fan	22
Level Auger Motor	46
SCR Drive	18-19
High Limit Switch	35
Hopper	46
Ignition Board & Box	44
Ignition Wires	20
Interlocks - For Magnetic Starters	56
Ladders - Rear	52
Ladders - Service Platform	51
Level Auger	
Belts	46
Motor	54-55
Motor Mount	48
Switch Assembly	35
Lights, Control Panel	40
LP Gas Liquid Lines	32
Magnetic Starters	54-55
Manifolds	30
Low Fire Manifolds - LP & Natural Gas	28
Mercury Switch	4
Metering Rolls	2-5
Mixing Chamber	13
Modulating Valves	30
Modulating Valve Power Elements	31
Modulating Valve Repair Kits	31
Moisture Control	
Potentiometer	41
Moisture Control	42
Thermistor Sensor	35
Motors	54-55
Peak	45
Portabilities	58
Pressure Gauge (Gas)	30
Pressure Regulator (LP Gas)	30
Pressure Regulator (LP Gas) Repair Kit	31
Relays	42
Relief Valve - LP Gas	32

Continued on next page

SCR Drive Unload System	
Control Board	42
Motor and Gear Box	18-19
Potentiometer	41
Screens	
Base Screens and Supports	7
Bottom Module Screens	8
8' Middle and Top Module Screens	10
5' Top Module Screens	12
Service Platforms and Ladders	51-52
Solenoid Valves	
1 ¼" - LP Gas and Natural Gas	31
½" - LP Gas	31
¾" - LP Gas and Natural Gas	28
Solenoid Valve Repair Kits	31
Standpipes - LP Gas Liquid Line	33-34
Switches, Control Panel	40
Terminal Tracks	42-43
Thermistor	35
Thermometer - 15' Capillary	26-27
Timers	
.1 to 8 Minute Adjustable - Level Auger	42
60 Minute Adjustable - Low Grain Level	42
Transformers	36
Unload Auger	
Auger	2
Belts - SCR Drive	18
Extension Kit (2 ft.)	57
Motor	54-55
Pans	6
Vaporizer Coil - LP Gas	20
Vaporizer to Manifold Pipe - LP Gas	32
Walkway	50

INTRODUCTION

Parts Ordering Instructions

1. Order parts from your local M-C Dealer or distributor.
2. Always furnish the Grain Dryer model and serial number. This information is stamped on the serial number plate.
3. When ordering parts be sure to furnish the part number, description and quantity required.

NOTE: Attaching hardware is listed, but not included with, the main part. It must be ordered separately.

4. Inspect all shipments upon receipt. If any packages and/or boxes are missing, or parts are damaged, file a claim with the carrier immediately. Failure to do so may void a claim. Check the shipment against the packing list carefully. Report any shortages to the shipper immediately.
5. Do not return any parts to the Mathews Company without a "Return Goods Authorization" from the factory. All return parts shipments must be shipped prepaid (COD shipments will not be accepted). Shipments must also include the following:
 - A. A letter of explanation including the "Return Goods Authorization Number," your name and address.
 - B. A list of all parts being returned. List must include part numbers, description, quantity, and original invoice number.

Model and Serial Number Location

The model and serial number of your grain dryer are stamped on a plate located on the left front

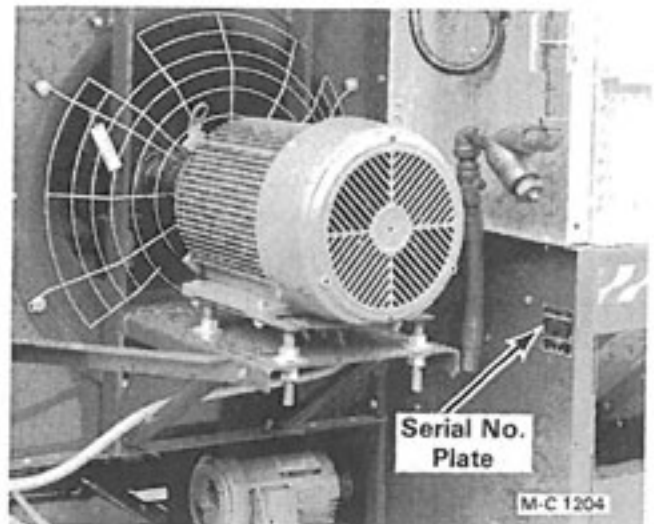

Figure 1

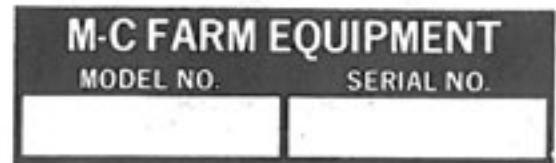

Figure 2

base panel, see Figure 1. For future reference, record the model and serial number in the blank spaces in Figure 2.

Capscrew Grade Identification

There are four grades of hex-head capscrews. Grade 1 and 2 are common capscrews, grade 5 and 8 are used when greater strength is required. Each grade can be identified by the marking on the head of the capscrew, see chart below.

When replacing capscrews, be sure to use the correct size and grade. If a specific grade is not shown as part of the description, the capscrew is a grade 1 or 2.

CAPSCREW GRADE IDENTIFICATION CHART

S.A.E. Grade	Description	Capscrew Head Marking*
1	WILL HAVE A PLAIN HEAD - NO RADIAL LINES	
2	Low or Medium Carbon Steel Not Heat Treated	
5	WILL HAVE 3 RADIAL LINES Quenched and Tempered Medium Carbon Steel	
8	WILL HAVE 6 RADIAL LINES Quenched and Tempered Special Carbon or Alloy Steel	

*The center marking identifies the capscrew manufacturer.

Metering Rolls and Unload Auger

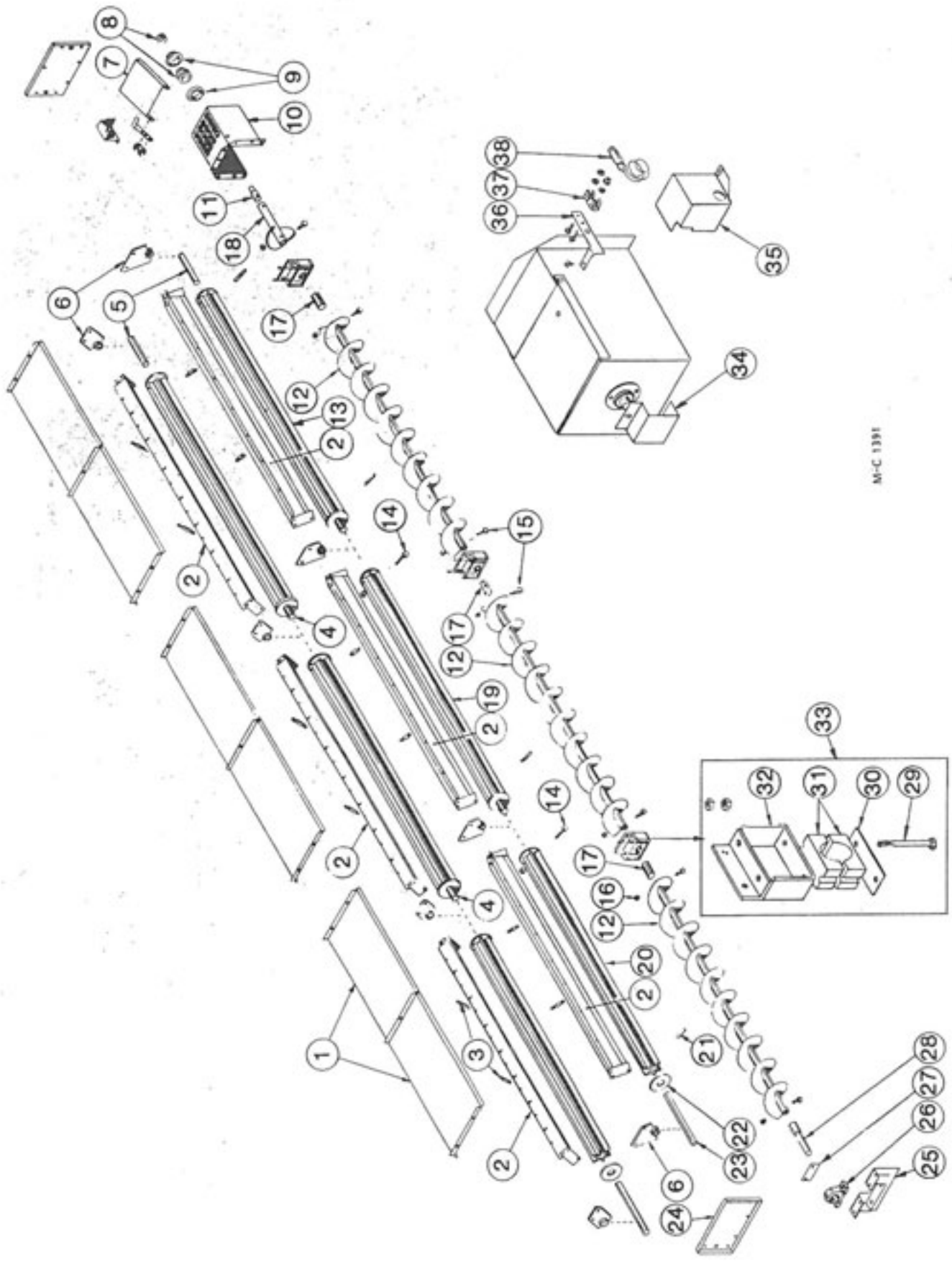

M-C 1391

Metering Rolls and Unload Auger

Ref.	Part No.	Qty. (16')	Qty. (24')	Description
1	128 2890	4	6	Unload Auger Cover
	001 8111	8	12	5/16-18 Clip Nut
	000 8106	12	21	5/16-18 x 3/4" Capscrew
	000 8173	12	21	5/16" Flatwasher
	000 8169	4	9	5/16-18 Flanged Locknut
2	128 0225	4	6	Inner Perf. Mt. Weld
	000 8106	18	24	5/16-18 x 3/4" Capscrew
	000 8169	18	24	5/16-18 Flanged Locknut
3	128 8958	8	12	Support Rod (1/4" x 4 3/4")
	000 8173	8	12	5/16" Flatwasher
	000 8168	24	36	3/8-16 Flanged Locknut
4	121 5043	2	4	Rear & Center Metering Roll Shaft-1 1/4x7" (press fit in metering roll)
5	121 5042	2	2	Rear Metering Roll Stub Shaft - 1 1/4"x5" (press fit in metering roll)
6	128 1063	6	8	Metering Roll Brg. w/Bronze Bushing
	000 8106	12	16	5/16-18 x 3/4" Capscrew
	000 8169	12	16	5/16-18 Flanged Locknut
7	128 4712	1	1	Over Load Door
	000 8119	2	2	3/8-16 x 3/4" Capscrew
	000 8205	2	2	3/8-16 Top Lock Flanged Nut
8	001 6003	1	1	1 1/4" Bearing w/Lock Collar
9	001 6004	2	2	1 1/4" Bearing Flangette
	000 8121	3	3	3/8-16 x 1" Capscrew
	000 8168	3	3	3/8-16 Flanged Locknut
10	128 0242	-	-	Unload Auger Discharge Square
	128 0328	-	-	Unload Auger Discharge Round (Front Unload - See note 1)
	000 8106	9	9	5/16-18 x 3/4" Capscrew
	000 8169	9	9	5/16-18 Flanged Locknut
11	124 5611	1	1	Unload Auger Output Shaft (Front Unload - See note 1)

NOTE 1: Dryers w/Front Unload - ref. 10, use 127 4431 rear cover plate, ref. 11, use 127 5999 output shaft and ref. 12, use 128 0243 auger.

Ref.	Part No.	Qty. (16')	Qty. (24')	Description
12	128 0244	2	3	Rear Unload Auger (10") (Front Unload - See note 1)
13	121 1082	2	2	Rear Metering Roll Ass'y. (incl. shafts)
14	000 8114	2	4	5/16-18 x 2 1/2" Capscrew
	000 8222	2	4	5/16" Lockwasher
	000 8159	2	4	5/16-18 Hex Nut
15	000 8229	8	12	3/8-16 x 2 3/4" Capscrew-Grd. 5
16	000 8205	8	12	Top-Lock Flange Nut
17	128 5618	2	3	Unload Auger Link
18	128 0309	1	1	Standard Auger Weld
19	121 1083	-	2	Center Metering Roll Ass'y. (incl. shaft)
20	128 1254	2	2	Front Metering Roll Ass'y. (incl. shaft)
21	000 8259	3	4	Roll Pin 5/16" x 1 3/4"
22	121 4438	AR	AR	Metering Roll Washer-11 Gauge
	128 4970	AR	AR	Metering Roll Washer-16 Gauge
23	128 5042	2	2	Front Metering Roll Shaft - 1 1/4" x 13 3/4" (press fit in metering roll)
24	128 2894	2	2	Base Panel Access Door (17 1/2"x10 1/2")
	001 8284	14	14	5/16-12 x 1/2" Self Tapping Screw
25	128 0247	1	1	Unload Auger Front Plate
	000 8119	4	4	3/8-16 x 3/4" Capscrew
	000 8168	4	4	3/8-16 Flanged Locknut

Continued on next page

Metering Rolls and Unload Auger

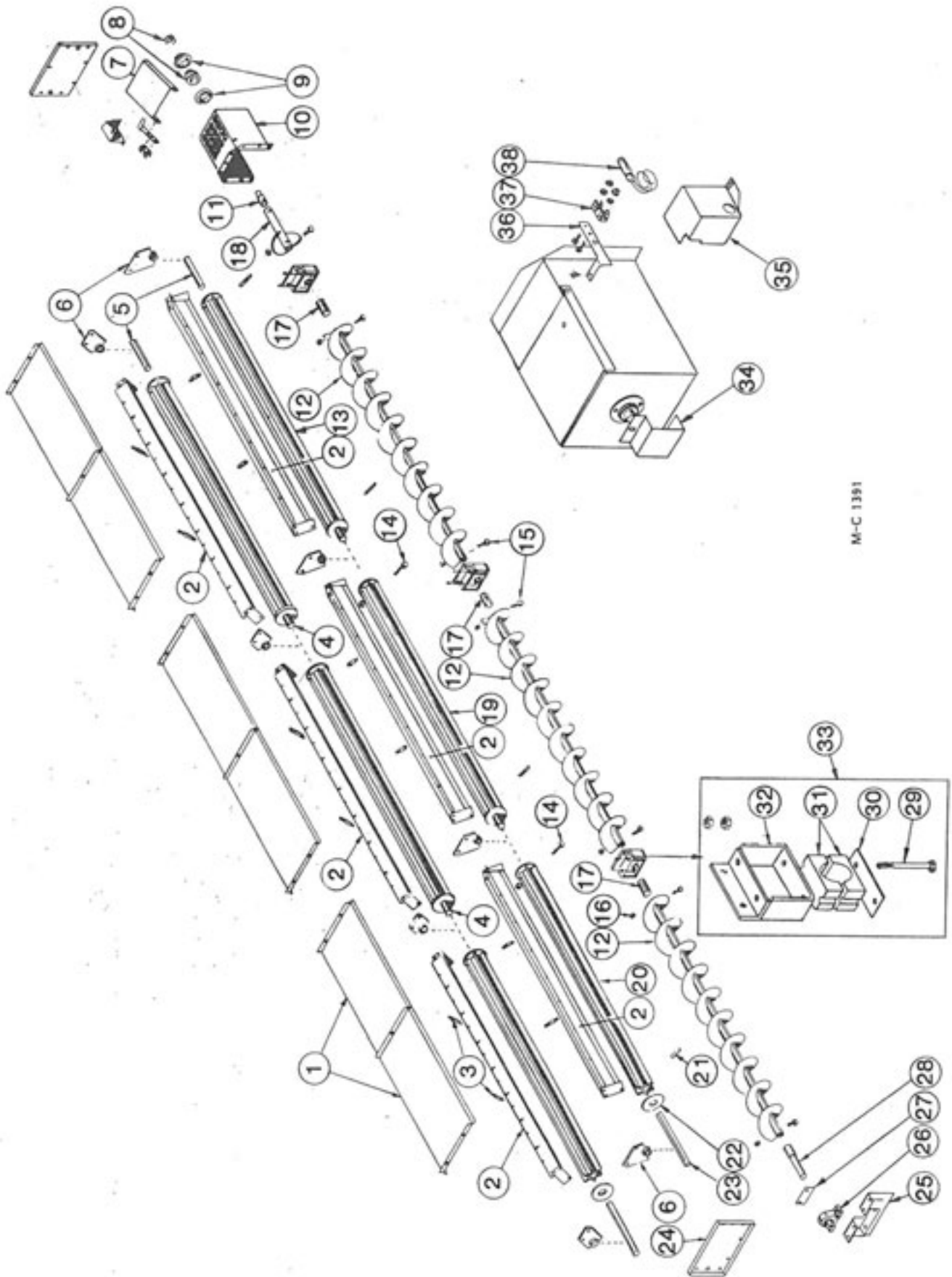

M-C 1391

Metering Rolls and Unload Auger

Ref.	Part No.	Qty. (16')	Qty. (24')	Description
26	001 6011	1	1	1-7/16" Bore Pillow Block Brg.
	001 8299	2	2	1/2-13 x 1 1/4" Capscrew-Grd. 8 w/Nylock
	001 8257	2	2	1/2" SAE Flatwasher
	000 8163	2	2	1/2-13 Hex Nut
27	128 3008	1	1	Front Seal Plate
	000 8184	4	4	8-18 x 1/2" Sheet Metal Screw
28	124 5610	1	1	Unload Auger Input Shaft
29	001 8168	4	6	1/2-13 x 4 1/2" Capscrew - Grd. 5
	000 8180	4	6	1/2" Lockwasher
	000 8163	8	12	1/2-13 Hex Nut
30	128 0285	2	3	Unload Auger Support Weld
31	128 6020	2	3	Wood Brg. 1-5/16" (2 Halves)
32	128 0287	2	3	Unload Auger Brg. Brkt.
	000 8137	4	6	1/2-13 x 1 1/4" Capscrew - Grd. 5
	000 8180	4	6	1/2" Lockwasher
	000 8163	4	6	1/2-13 Hex Nut
33	122 1007	2	3	Unload Auger Brg. Kit (Incl. ref. 30 thru 33 in quantities reqd. for one brg.)
34	128 3011	1	1	Stub Shaft Guard
35	128 4896	1	1	Shut-Off Switch Cover
	001 8284	2	2	5/16-12 x 1/2" Self-Tapping Screw
36	128 2937	1	1	Bulb Mount
37	120 6801	1	1	Mercury Switch Mt. Clip
	000 8282	2	2	6-32 x 1/4" Machine Screw
	000 8185	2	2	6-32 Flanged Locknut
38	120 6800	1	1	Mercury Switch

Unload Auger Pans

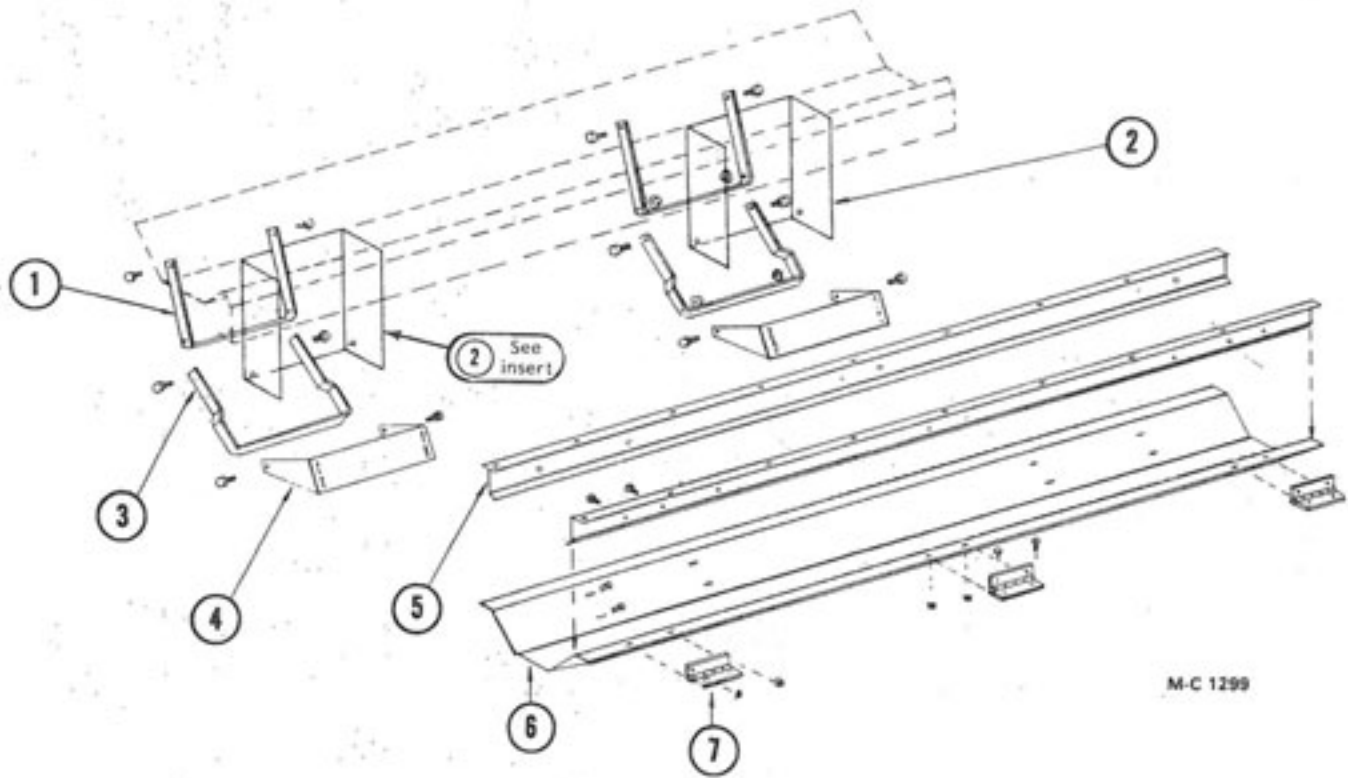

M-C 1299

2 WARNING DECAL
MOUNTS ON SIDE
OF BRACKET

Ref. Part No.	Qty. (16')	Qty. (24')	Description
1 128 2029	4	6	Auger Dump Arm - Upper
2 128 8355	4	6	Warning Decal (not shown)
3 128 2030	4	6	Auger Dump Arm - Lower
4 128 2751	4	6	Bottom Link Pivot Base
5 127 2673	4	6	Pan Hinge Angle
6 128 2752	2	3	Auger Dump Pan
7 128 8957	6	9	Hinge

Base Screens and Supports

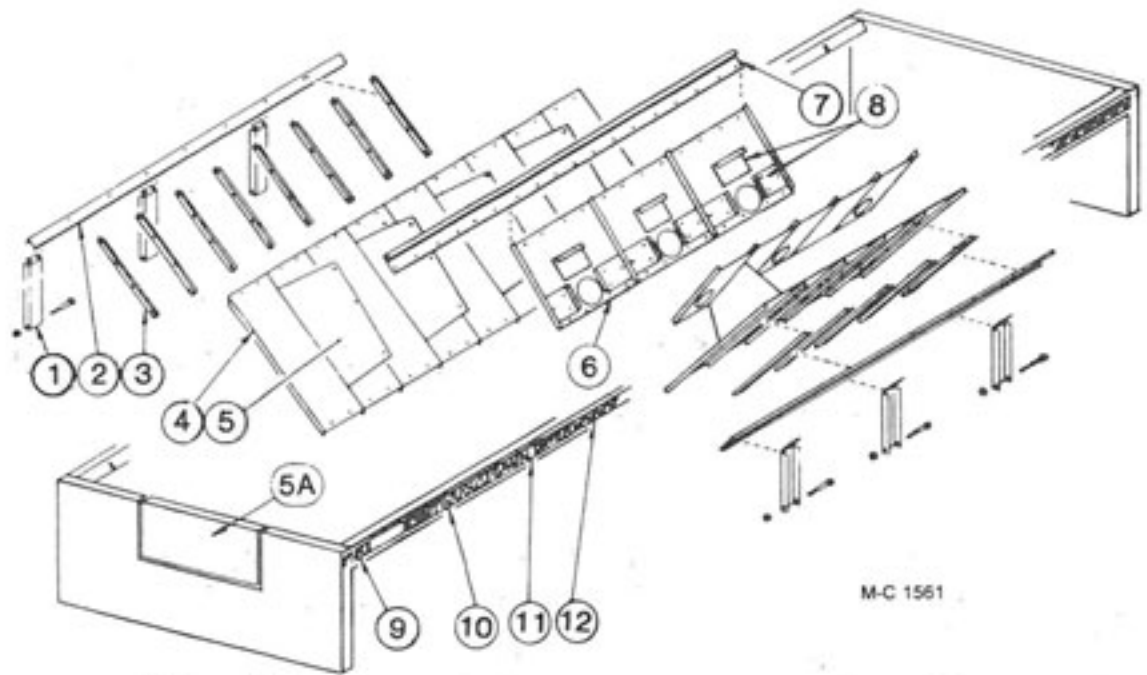

Ref.	Part No.	Qty. (16')	Qty. (24')	Description	Ref.	Part No.	Qty. (16')	Qty. (24')	Description
NOTE: Ref. 1, 2 & 3 for 1180. only.					6	-----	—	—	Lower Inner Screen w/ Clean-Out
1	124 4211	10	16	Channel Support		128 2994	32	48	Galvanized (Std.)
	001 8275	—	—	3/8-16 x 4" Hex-Hd. Capscrew- Grd. 5		127 2960	32	48	Small Seed (Galv)
	001 8149	—	—	3/8-16 Two Way Locknut	7	128 2739	4	6	Lower Screen Mt. Angle
2	124 4212	4	6	Screen Support Channel	8	128 2995	32	48	Lower Inner Screen Cover
3	128 2664	34	50	Screen Support Angle		128 3003	16	24	Slope Door
4	127 2945	32	48	Small Seed (Galv)		124 2866	32	48	Door Retainer
5	128 2855	6	10	Lower Screen Stiffener	9	128 8300	2	2	M-C Decal - 5" x 4-9/16"
5A	128 4570	1	1	Base Filler Panel (37" x 13 1/2")	10	128 8308	2	2	"Continuous" Decal
	001 8135	12	12	3/8-16 x 1" Capscrew - Grd. 5	11	128 8309	2	2	"Grain Dryer" Decal
	000 8168	12	12	3/8-16 Flanged Locknut	12	128 8310	24ft.	39ft.	Red & Yellow Stripe Decal-2 1/2"

NOTE: Hardware to bolt screens together for base screens, module screens and peak screens are as follows:

- 001 8208 - 5/16-18 x 1/2 HWHCS
- 001 8202 - 5/16-18 x 3/4 HWHCS
- 000 8169 - 5/16-18 Whiz Lock Nut

Bottom Module Screens

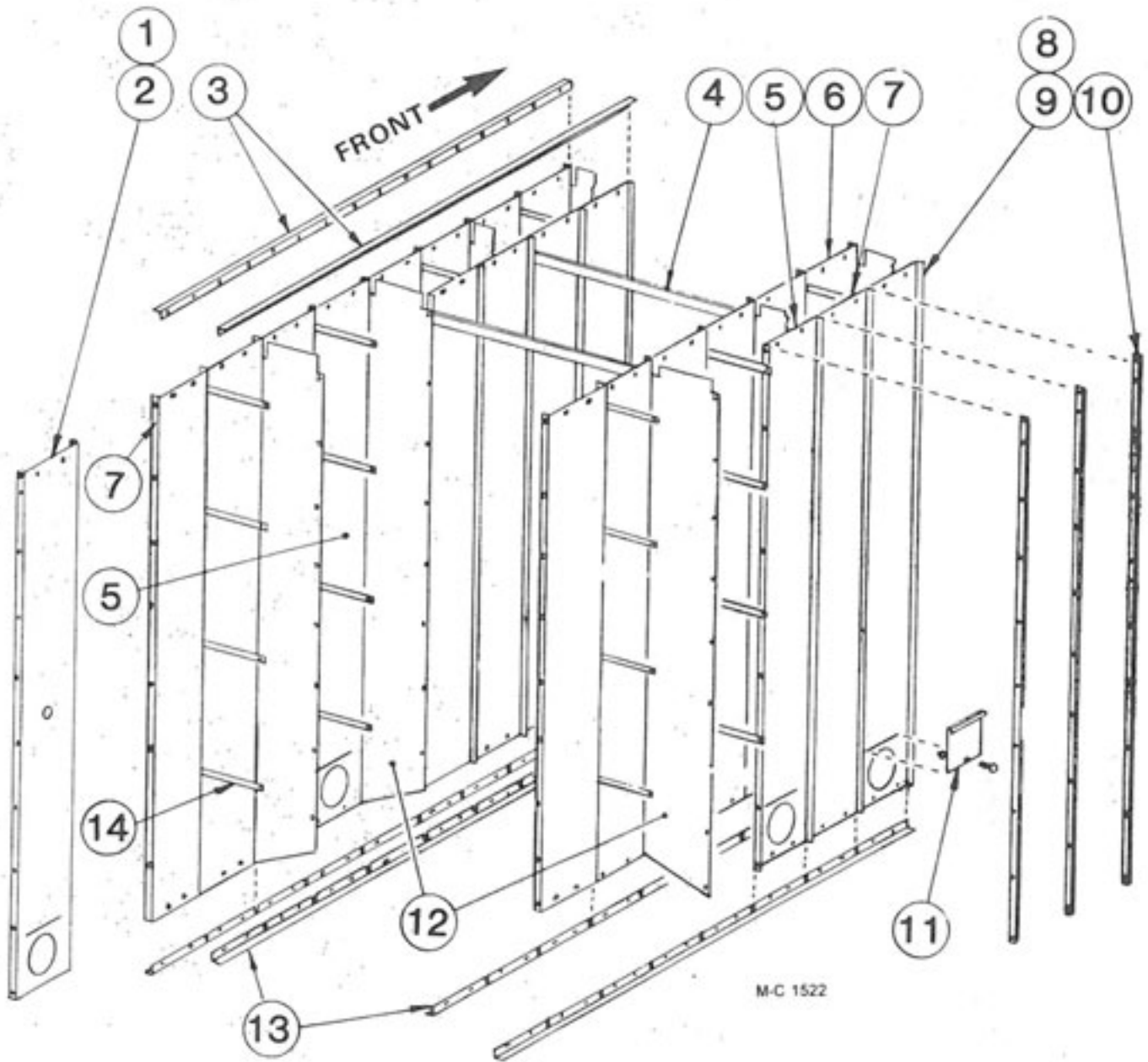

M-C 1522

Bottom Module Screens

NOTE: Quantities shown are for dryers with quick drains in every other grain column and solid dividers in every second grain column.

Ref.	Part No.	Qty. (16')	Qty. (24')	Description	Ref.	Part No.	Qty. (16')	Qty. (24')	Description
1	---	—	—	Moisture Control Screen	8	---	—	—	Outer End Screen w/o Quick Drain Hole
	128 2971	1	1	Galvanized (Std.)		128 2965	2	2	Galvanized (Std.)
	127 2955	1	1	Small Seed (Galv)		127 2952	2	2	Small Seed (Galv.)
	123 5209	1	1	Aluminum		123 5208	2	2	Aluminum
2	---	—	—	Moisture Control Screen w/Quick Drain Hole	9	---	—	—	Outer End Screen w/Quick Drain Hole
	127 2989	1	1	Galvanized (Std.)		128 3000	2	2	Galvanized (Std.)
	127 2988	1	1	Small Seed (Galv)		127 2961	2	2	Small Seed (Galv.)
3	128 2382	4	—	Side Joiner Angle	10	128 2250	30	46	Screen Stiffener Bar (not used on 680 & 980)
	128 2381	—	4	Side Joiner Angle					
4	128 2014	7	11	Inner Screen Cross Tie	11	---	—	—	Quick Drain Door For Galvanized (Std.) and Aluminum Screens
5	---	—	—	Outer Screen w/Quick Drain Hole		127 2950	16	24	For Galvanized (Std.) and Aluminum Screens
	127 2949	14	22	Galvanized (Std.)		127 2974	16	24	For Small Seed Screens (Galv.)
	127 2962	14	22	Small Seed (Galv)		001 8269	16	24	3/8-16 x 3/4" Carriage Bolt
	123 2349	14	22	Aluminum		000 8168	16	24	3/8-16 Flanged Locknut
6	---	—	—	Inner Screen	12	128 2871	14	22	Divider Panel
	128 2974	32	48	Galvanized (Std.)	13	125 2732	8	12	Screen Mount Angle
	127 2954	32	48	Small Seed (Galv)	14	121 3007	64	96	Column Stiffener Strap
7	---	—	—	Outer Screen w/o Quick Drain Hole					
	128 2945	13	21	Galvanized (Std.)					
	127 2948	13	21	Small Seed (Galv.)					
	123 2955	13	21	Aluminum					

NOTE: Hardware to bolt screens together for base screens, module screens and peak screens are as follows:

- 001 8208 - 5/16-18 x 1/2 HWHCS
- 001 8202 - 5/16-18 x 3/4 HWHCS
- 000 8169 - 5/16-18 Whiz Lock Nut

8' Middle and Top Module Screens

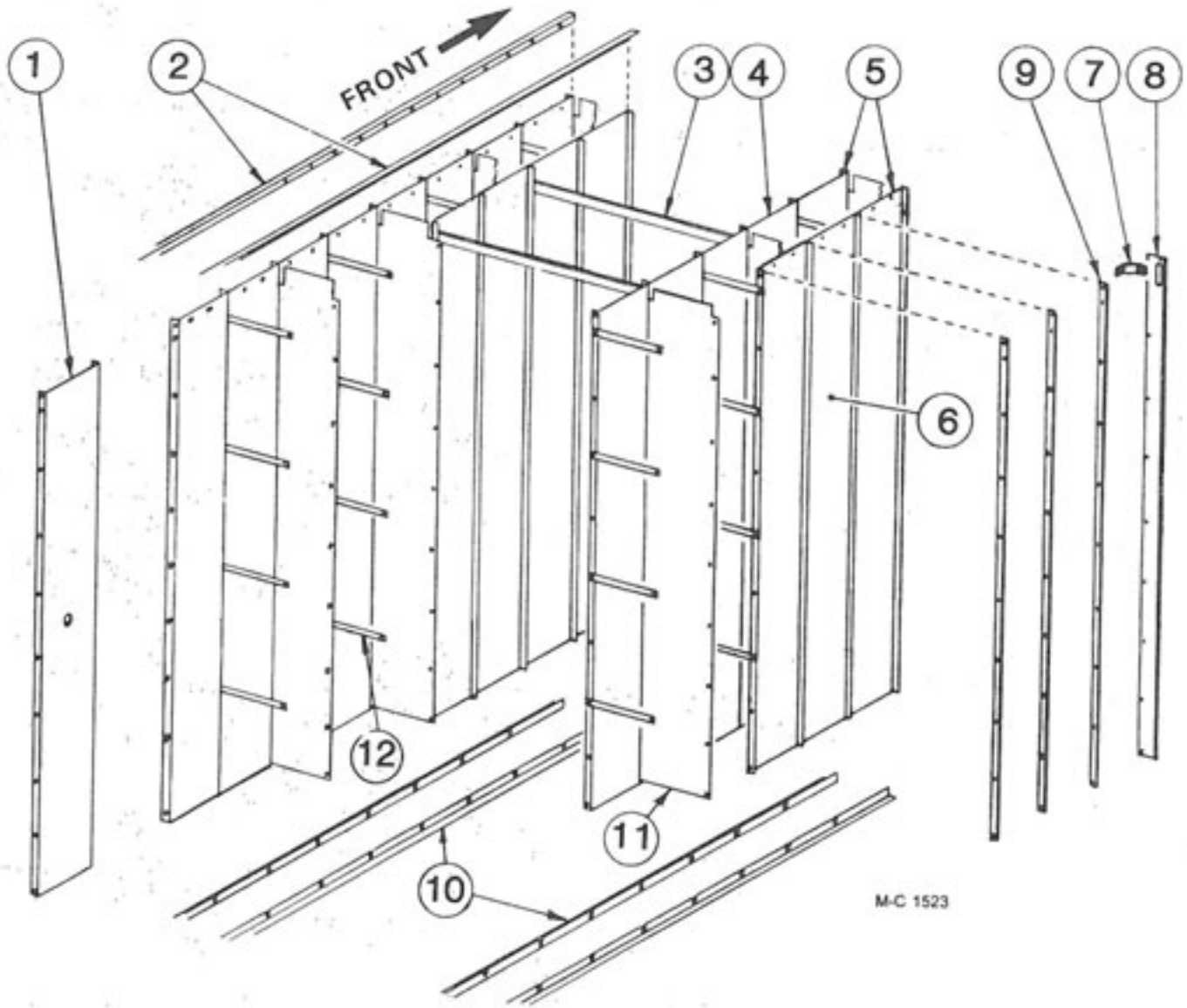

M-C 1523

8' Middle and Top Module Screens

NOTE: Quantities shown are for one module.

Ref.	Part No.	Qty. (16')	Qty. (24')	Description	Ref.	Part No.	Qty. (16')	Qty. (24')	Description
1	---	—	—	Moisture Control Screen (See note 1)	6	---	—	—	Outer Screen (See note 3)
	128 3005	1	1	Galvanized (Std.)		128 2945	27	43	Galvanized (Std.)
	127 2994	1	1	Small Seed (Galv)		127 2948	27	43	Small Seed (Galv.)
	129 7702	1	1	Aluminum		123 2955	27	43	Aluminum
2	128 2382	4	—	Side Joiner Angle	7	129 3402	6	6	Lift Bar Bracket
	128 2381	—	4	Side Joiner Angle	8	128 3437	4	4	Lift Bar
3	128 2014	7	11	Inner Screen Cross Tie	9	128 2250	30	46	Screen Stiffener Bar
4	---	—	—	Inner Screen	10	125 2732	8	12	Screen Mount Angle
	128 2945	28	44	Galvanized (Std.)	11	128 2901	14	22	Divider Panel
	127 2948	28	44	Small Seed (Galv.)	12	121 3007	64	96	Column Stiffener Straps
5	---	—	—	Outer and Inner End Screen					
	128 2965	8	8	Galvanized (Std.)					
	127 2952	8	8	Small Seed (Galv.)					
	123 5208	4	4	Aluminum (Outer only-see note 2)					

NOTE 1: Used on the middle module of 1180.

NOTE 2: Use four standard end screens (128 2965) with inner screens.

NOTE 3: Add one to the quantity for the top module of 1180.

5' Top Module Screens

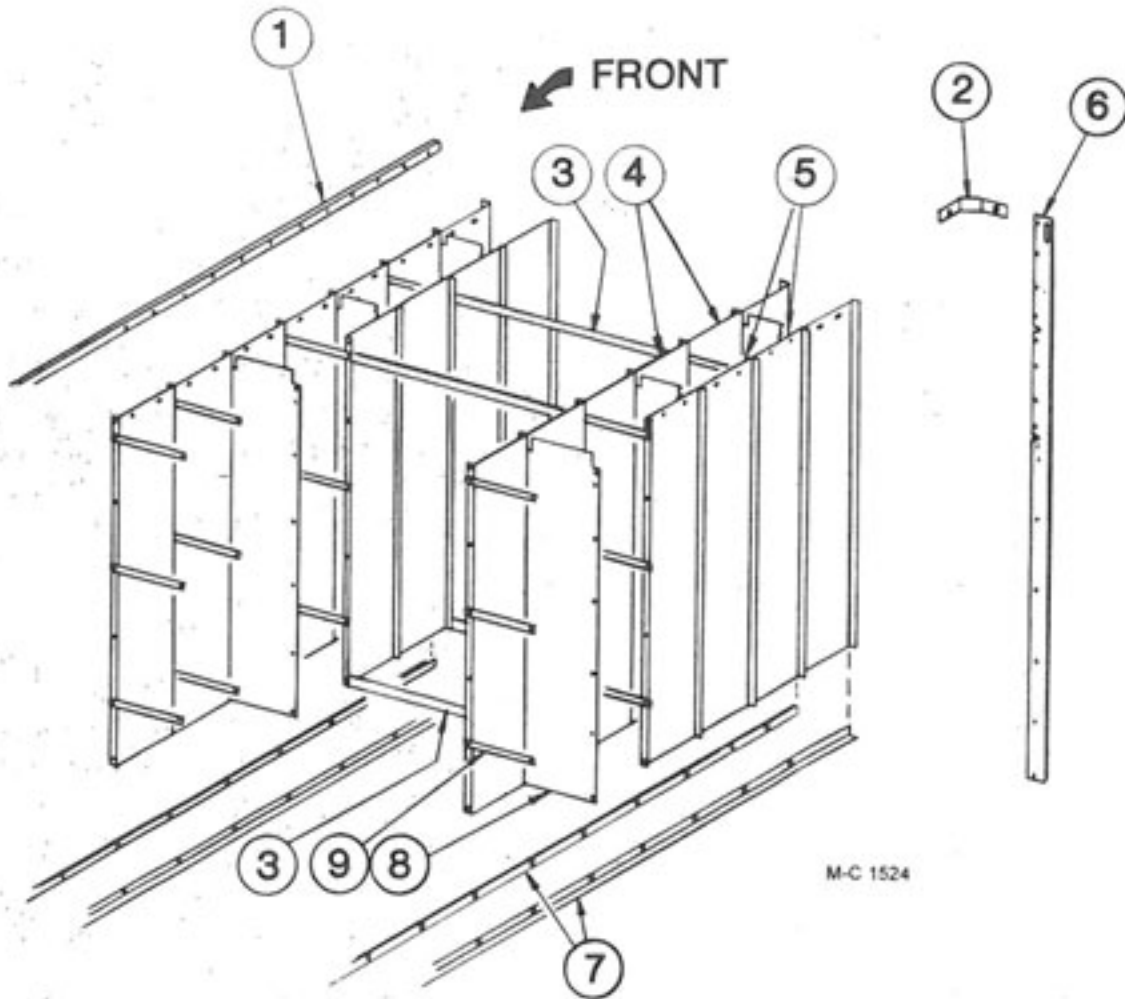

Ref.	Part No.	Qty. (16')	Qty. (24')	Description
1	128 2382	4	--	Side Joiner Angle
	128 2381	--	4	Side Joiner Angle
2	129 3402	6	6	Lifting Bar Brace
3	128 2014	14	22	Inner Screen Cross Tie
	-----	--	--	Inner Screen
4	128 2972	32	48	Galvanized (Std.)
	127 2951	32	48	Small Seed (Galv.)
5	-----	--	--	Outer Screen
	128 2972	32	48	Galvanized (Std.)
	127 2951	32	48	Small Seed (Galv.)
	127 2990	32	48	Aluminum
6	123 3414	4	4	Lifting Bar 5'(Conversion module only)
7	125 2732	8	12	Screen Mount Angle
8	128 2907	14	22	Divider Panel
9	121 3007	48	72	Column Stiffener Straps

Mixing Chamber

Mixing Chamber

Ref.	Part No.	Qty.	Description
1	128 2915	2	Chamber Top-End
2	128 2912	2	Chamber Top-Left
3	128 2911	2	Chamber Top-Right
4	128 2918	2	Chamber Side
5	128 2914	1	Chamber Deflector
6	001 3302	2	Universal Angle Clip
-	000 8106	48	5/16-18 x 3/4" Capscrew
-	000 8169	48	5/16-18 Flanged Locknut
-	000 8173	48	5/16" Flatwasher
-	000 8184	48	8-18 x 1/2" Sheet Metal Screw
-	128 6848	1	3/4" K.O. Bushing
-	128 6830	2	Hole Plug

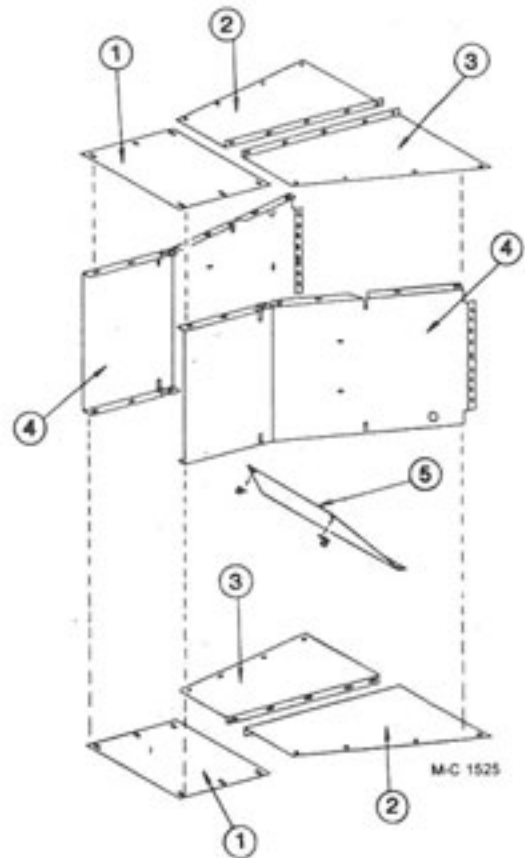

680 & 980 Lower Mixing Chamber

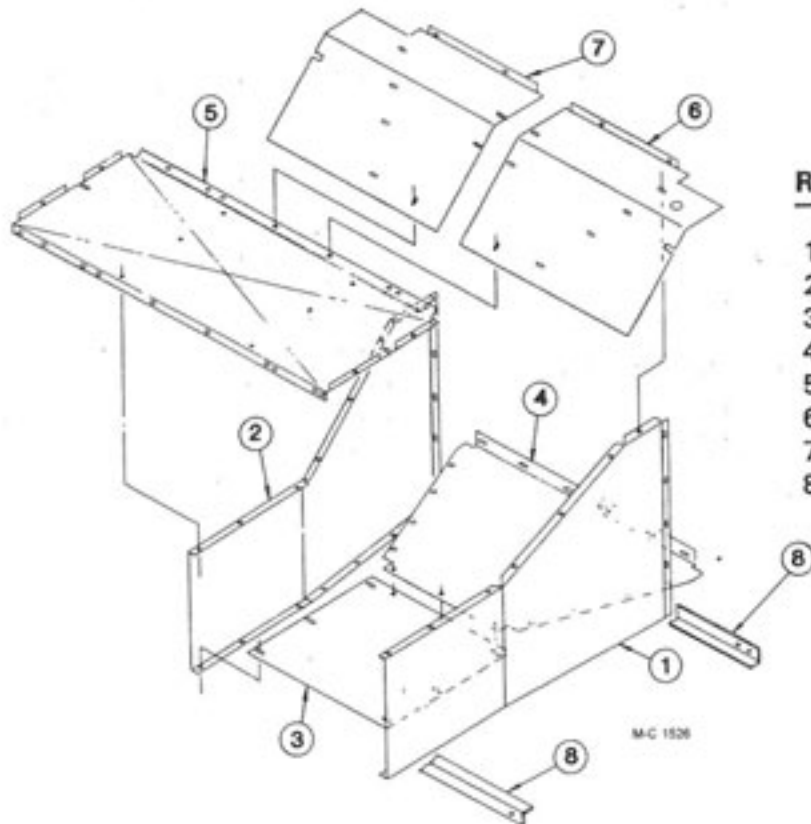

Ref.	Part No.	Qty.	Description
1	124 2863	1	Chamber Side-Right
2	124 2862	1	Chamber Side-Left
3	128 2915	1	Mixing Chamber-End
4	124 2859	1	Mixing Floor-Lower
5	124 2861	1	Pre-Slope Floor Panel
6	124 2856	1	Mixing Cover Top-Right
7	124 2860	1	Mixing Cover Top-Left
8	128 2014	2	Inner Cross Angle

Bottom Module End Panels and Floor Panels

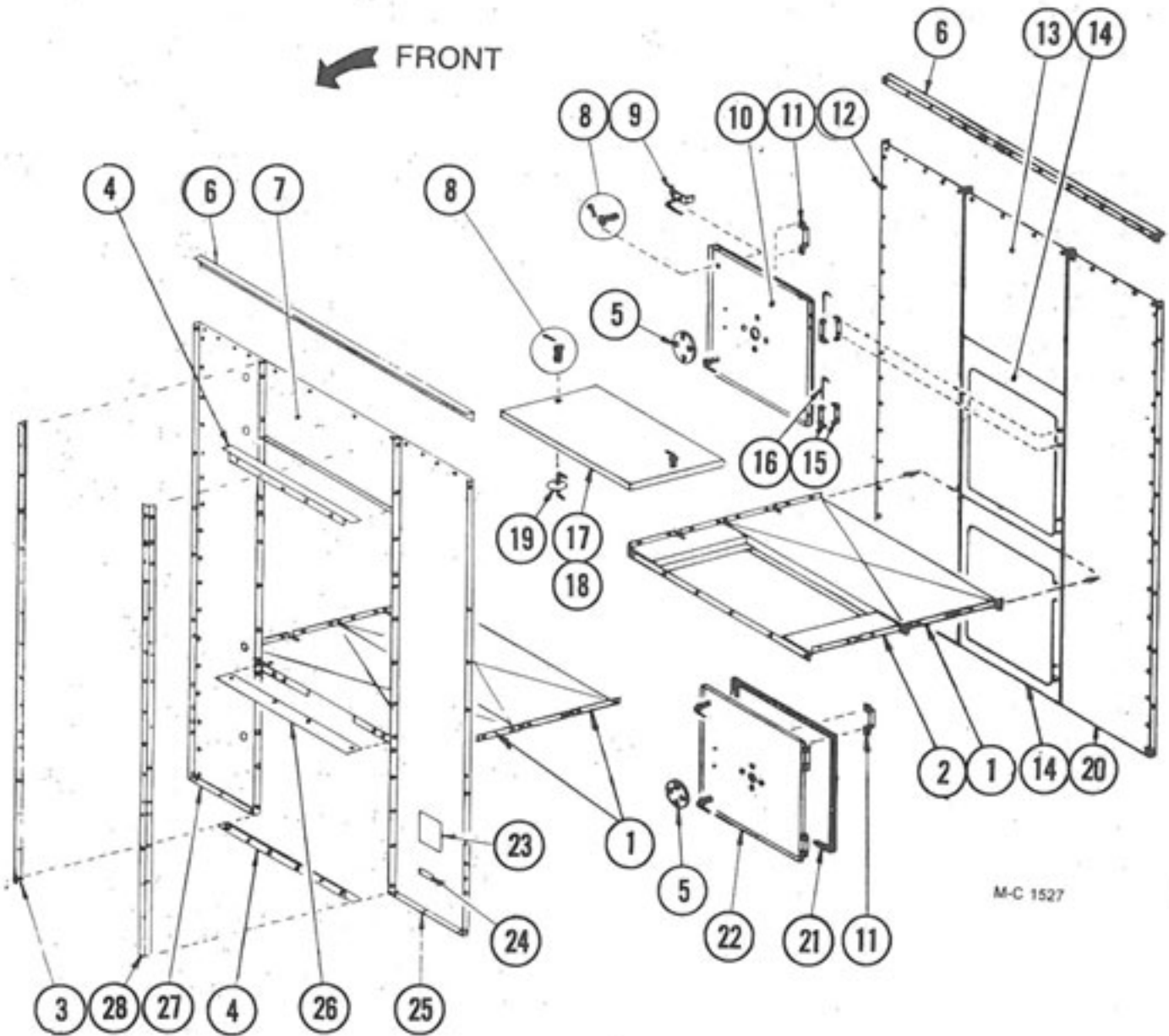

M-C 1527

Bottom Module End Panels and Floor Panels

Ref.	Part No.	Description
1	121 2928	Unit Floor Panel
2	121 0299	Heat Chamber Door Frame
3	128 2677	Fan Housing Mt. - Right
4	128 2644	Fan Housing Mt. Angle
5	129 5709	Port View Lens
6	128 2635	End Panel Joiner Angle
7	128 2900	Panel Above Fans
8	001 8256	Spring- $\frac{3}{8}$ " ID x 2"
	000 8174	$\frac{3}{8}$ " Flatwasher
	000 8199	$\frac{1}{8}$ " x 1" Cotter Pin
9	121 0414	Latch and Handle
10	128 2957	Rear Door Panel
	128 3012	Rear Door Panel 680/980
11	121 2887	Door Handle
	128 8251	8-18 x $\frac{1}{2}$ " Sheet Metal Screw
12	128 2867	Rear End Panel - Right
13	128 2876	Panel Above Rear Door
14	128 2715	Rear Door Frame
	128 2759	Rear Door Frame 680/980
15	128 2740	Door Hinge
	000 8212	$\frac{1}{4}$ -20 x $\frac{1}{2}$ " Truss Hd. Screw
	000 8167	$\frac{1}{4}$ -20 Flanged Locknut
16	128 5201	Hinge Pin
17	121 1113	Heat Chamber Door Ass'y. (Incl. ref. 8, 18 & 19)
18	121 2970	Heat Chamber Door Panel
19	121 0302	Latch and Handle
20	128 2866	Rear End Panel-Left
21	121 8966	Weather Stripping
22	128 1183	Rear Door Assembly
	124 1128	Rear Door Assembly 680/980 (Incl. ref. 8 thru 11, 15 & 21)
23	127 8300	"CGA" Dryer Plate (Canada only)
24	121 8310	Made in USA - Decal
25	128 2868	Front End Panel - Left
26	128 2992	Floor Seal
27	128 2869	Front End Panel - Right
28	128 2678	Fan Housing Mt. - Left

8' Module End Panels and Floor Panels

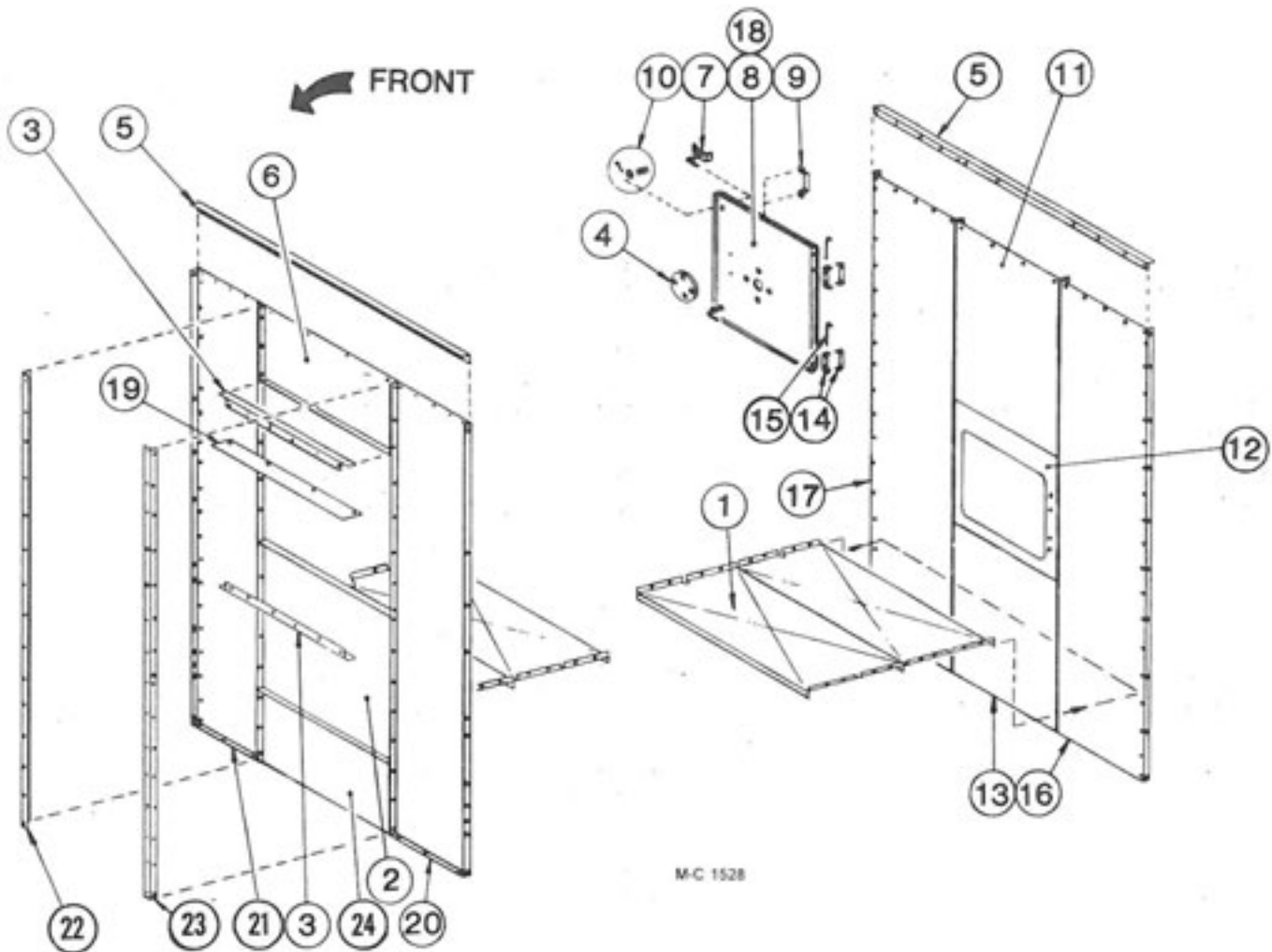

M-C 1528

(47)

Ref.	Part No.	Description
1	121 2928	Unit Floor Panel
2	124 2854	Panel Below Fan Housing
3	128 2644	Fan Housing Mt. Angle
4	129 5709	Port View Lens
5	128 2635	End Panel Joiner Angle
6	128 2900	Spacer Panel
7	121 0414	Latch and Handle
8	128 1183	Rear Door Ass'y. (Incl. ref. 10 thru 13, 17 & 21)
9	121 2887	Door Handle
10	001 8256	Spring - 5/8" ID x 2"
	000 8174	5/8" Flatwasher
	000 8199	1/8" x 1" Cotter Pin
11	128 2876	Panel Above Door
12	128 2715	Rear Door Frame

Ref.	Part No.	Description
13	128 2888	Filler Panel
14	128 2740	Door Hinge
	000 8212	1/4"-20 x 1/2" Truss Hd. Screw
	000 8167	1/4"-20 Flanged Locknut
15	128 5201	Hinge Pin
16	128 2866	Rear End Panel - Left
17	128 2867	Rear End Panel - Right
18	128 2957	Rear Door Panel
19	128 2992	Floor Seal
20	128 2868	Front End Panel - Left
21	128 2869	Front End Panel - Right
22	128 2653	Fan Housing Mt. - Right
23	128 2654	Fan Housing Mt. - Left
24	128 2899	Bottom Panel

5' Module End Panels

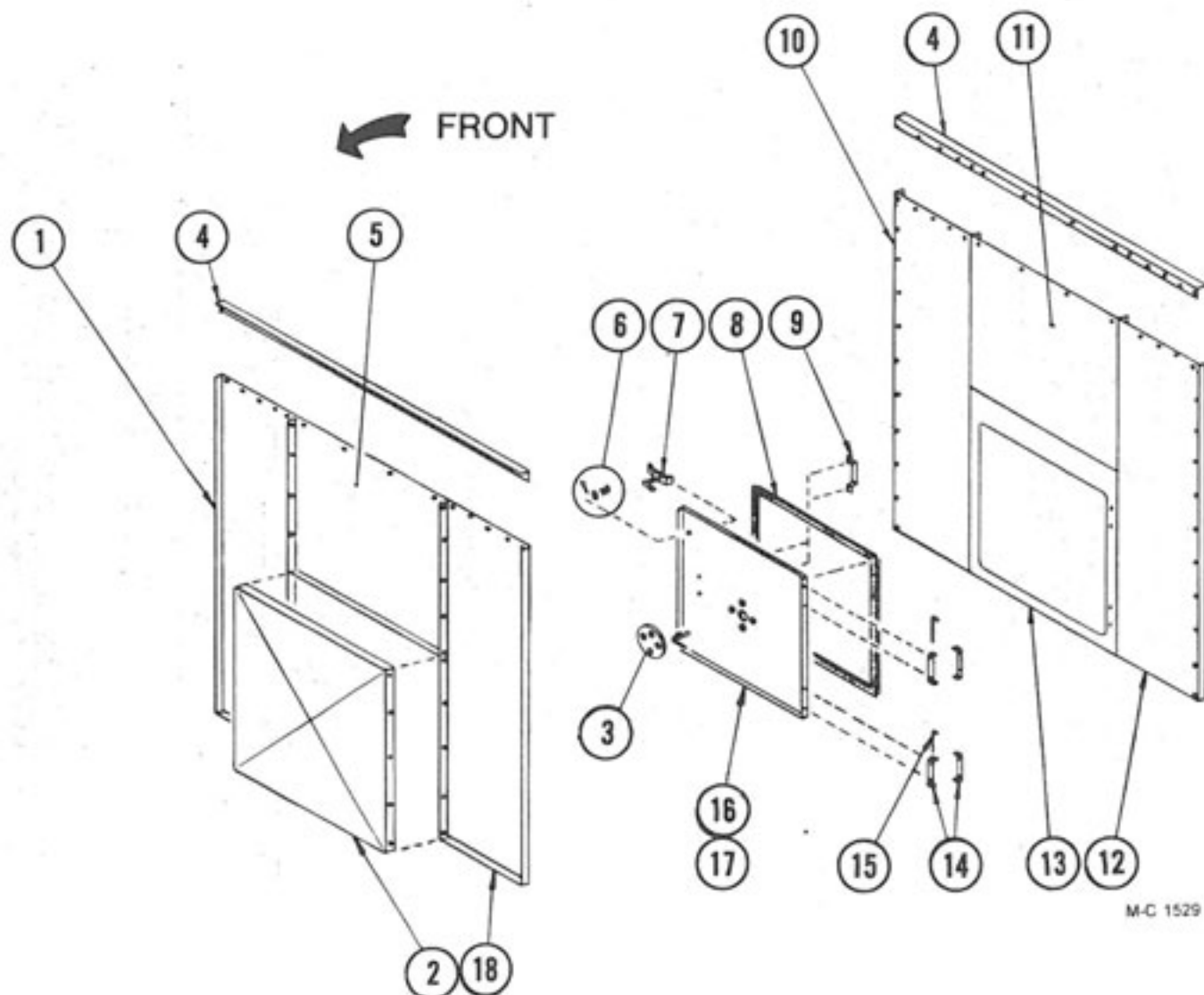

Ref.	Part No.	Description
1	128 2845	Front End Panel - Right
2	128 2763	Front Filler Panel
3	129 5709	Port View Lens
4	128 2635	End Panel Joiner Angle
5	128 2848	Panel Above Fan
6	001 8256	Spring $\frac{3}{8}$ " ID x 2"
	000 8174	$\frac{3}{8}$ " Flatwasher
	000 8199	$\frac{1}{8}$ " x 1" Cotter Pin
7	121 0414	Latch and Handle
8	121 8966	Weather Stripping
9	121 2887	Door Handle
	128 8251	8-18.x $\frac{1}{2}$ " Sheet Metal Screw

Ref.	Part No.	Description
10	128 2844	Rear End Panel - Right
11	128 2847	Panel Above Rear Door
12	128 2843	Rear End Panel - Left
13	128 2715	Rear Door Frame
14	128 2740	Door Hinge
	000 8212	$\frac{1}{4}$ -20 x $\frac{1}{2}$ " Truss Hd. Screw
	000 8167	$\frac{1}{4}$ -20 Flanged Locknut
15	128 5201	Hinge Pin
16	128 1183	Rear Door Ass'y. (Incl. ref. 6 thru 9, 14 & 17)
17	128 2957	Rear Door Panel
18	128 2846	Front End Panel - Left

SCR Drive Motor and Gear Box

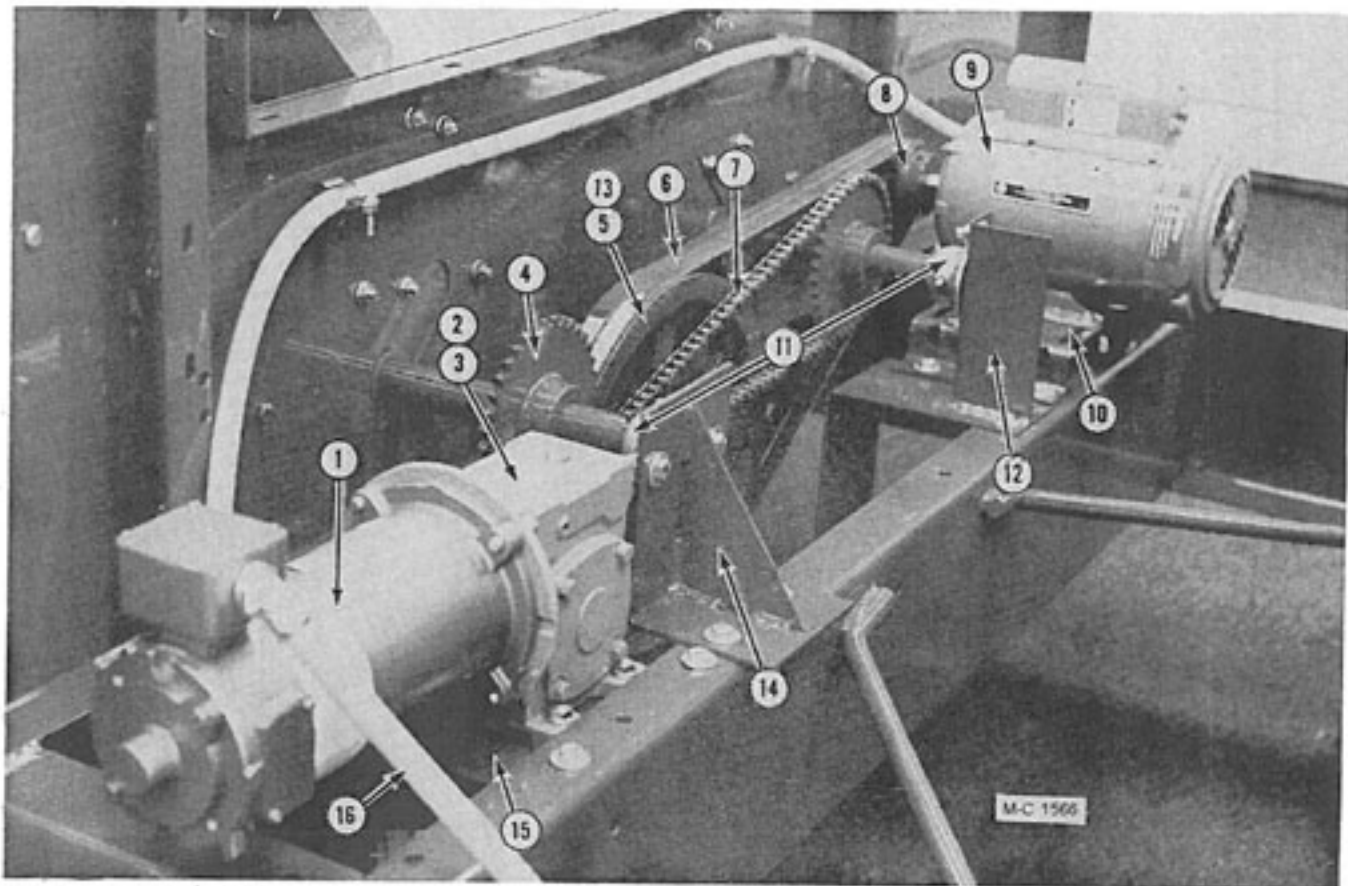

Ref.	Part No.	Qty.	Description	Ref.	Part No.	Qty.	Description
1	124 6837	1	DC Motor - 1/3 HP	9	127 6860	-	230/460V 1.5HP 3Ø Motor
	122 8613	-	DC Motor Brush		121 6861	-	230/460V 2HP 3Ø Motor
2	124 6624	1	SCR Gear Box (Incl. 3/16" x 1" Key- 001 5110)	001 5112	1	1	Key - 3/16" x 1 1/8" (For 1 1/2 HP motor)
	128 8947	1	Pint of Mobil SHC 634 Oil	001 5114	1	1	Key-3/16" x 1 1/8" (For 2 HP motor)
	000 8123	4	3/8-16 x 1 1/4" Capscrew	128 1810	1	1	Motor To Cabinet Wire Ass'y.
	000 8174	4	3/8" Flatwasher	000 8110	1	1	5/16-18 x 1 1/2" Capscrew
	000 8168	4	3/8" Flanged Locknut	000 8108	3	3	5/16-18 x 1" Capscrew
3	128 6422	1	SCR Gear Box Sprocket (not shown) RC-40 12T, 3/8" Bore	000 8173	8	8	5/16" Flatwasher
4	128 6423	2	Sprocket-RC40-36T-1 1/4" Bore	000 8169	4	4	5/16-18 Flanged Locknut
	000 8298	2	Woodruff Key - 1/4" x 3/4"	10	124 4214	1	Unload Auger Motor Mt.
5	021 6201	1	Pulley-2B x 13.6 SK	000 8121	4	4	3/8-16 x 1" Capscrew
	001 5130	1	Key - 3/8" x 1"	001 8132	1	1	3/8-16 x 4" "J" Bolt
6	021 6100	1	B-65 Belts (Matched set of 2)	000 8174	5	5	3/8" Flatwasher
7	128 6315	1	Chain - RC-40 x 130 Pitch	000 8168	5	5	3/8-16 Flanged Locknut
	002 6309	-	Connecting Link	11	121 6022	2	1 1/4" Outboard Brg.
8	121 6210	1	Pulley - 2B - 3-3/16"OD - 3/8" Bore	000 8121	4	4	3/8-16 x 1" Capscrew
	121 6203	1	Pulley-2B - 3-3/16"OD - 3/8" Bore	000 8174	4	4	3/8" Flatwasher
				000 8168	4	4	3/8-16 Flanged Locknut
				12	128 0257	1	Gear Mt. Motor Weld.
				000 8119	4	4	3/8-16 x 3/4" Capscrew
				000 8174	4	4	3/8" Flatwasher
				000 8168	4	4	3/8-16 Flanged Locknut

Continued on next page

SCR Drive Motor and Gear Box

Ref.	Part No.	Qty.	Description
13	001 6202	1	SK Bushing - 1-7/16" Bore (Incl. capscrews)
14	128 0191	1	Outboard Brg. Mount
15	124 4456	1	Gear Box Mount
	000 8119	4	3/8-16 x 3/4" Capscrew
	000 8174	4	3/8" Flatwasher
	000 8168	4	3/8-16-Flanged Locknut
16	128 1808	1	SCR Motor to Cabinet Flexible Conduit (51")
	128 1999	1	SCR Motor to Cabinet Flexible Conduit (40")
17	124 4803	4	Drive Cover Brkt-Long
	124 4804	4	Drive Cover Brkt-Short
	000 8104	6	5/16-18 x 3/4" Truss Hd. Screw
	000 8169	6	5/16-18 Flanged Locknut
18	124 4802	1	SCR Guard with Motor Hole
19	124 4809	1	SCR Guard

Not Shown

—	120 6914	1	Chase Nipple - 1/2"
—	121 6906	2	Pipe Clamp
	000 8212	2	1/4-20 x 1/2" Truss Hd. Screw
	000 8167	2	1/4-20 Flanged Locknut

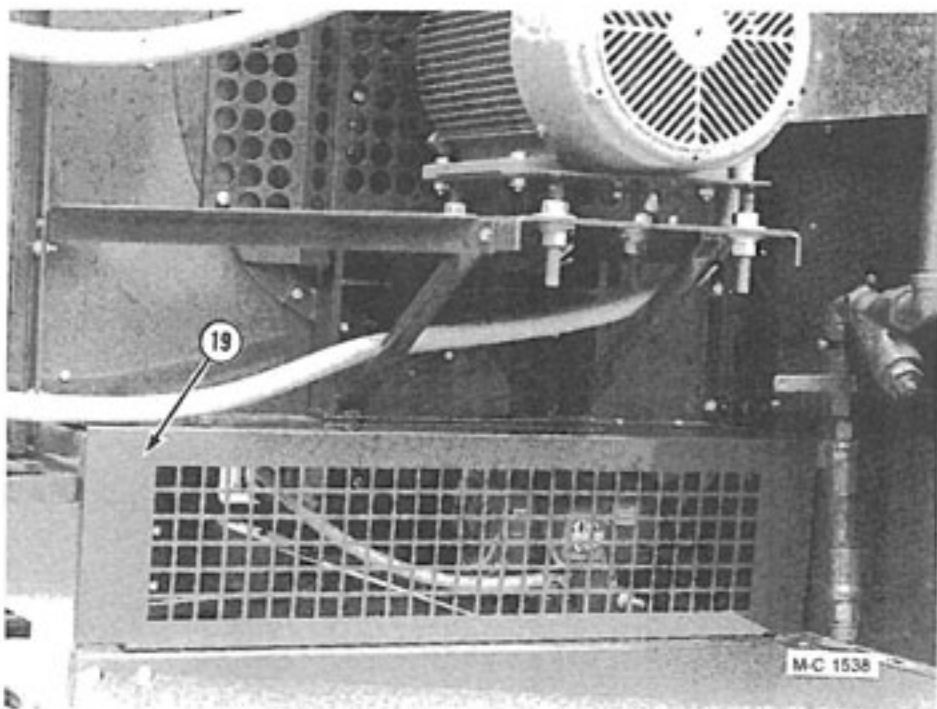
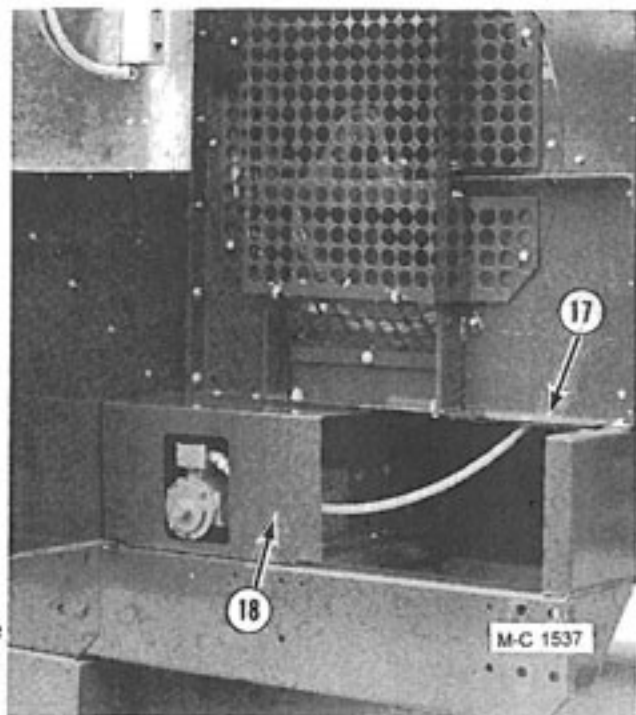

Venturi Burner

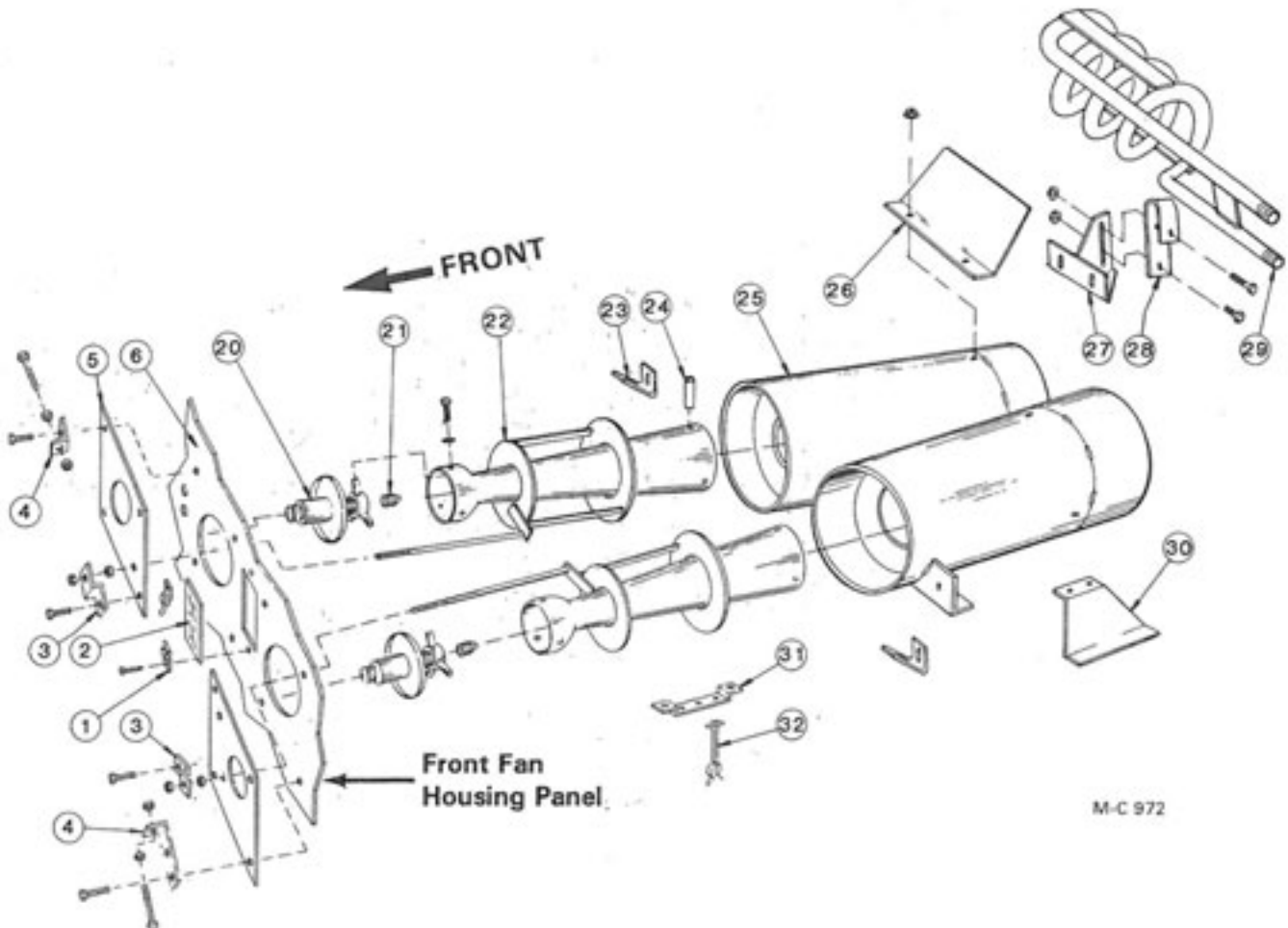
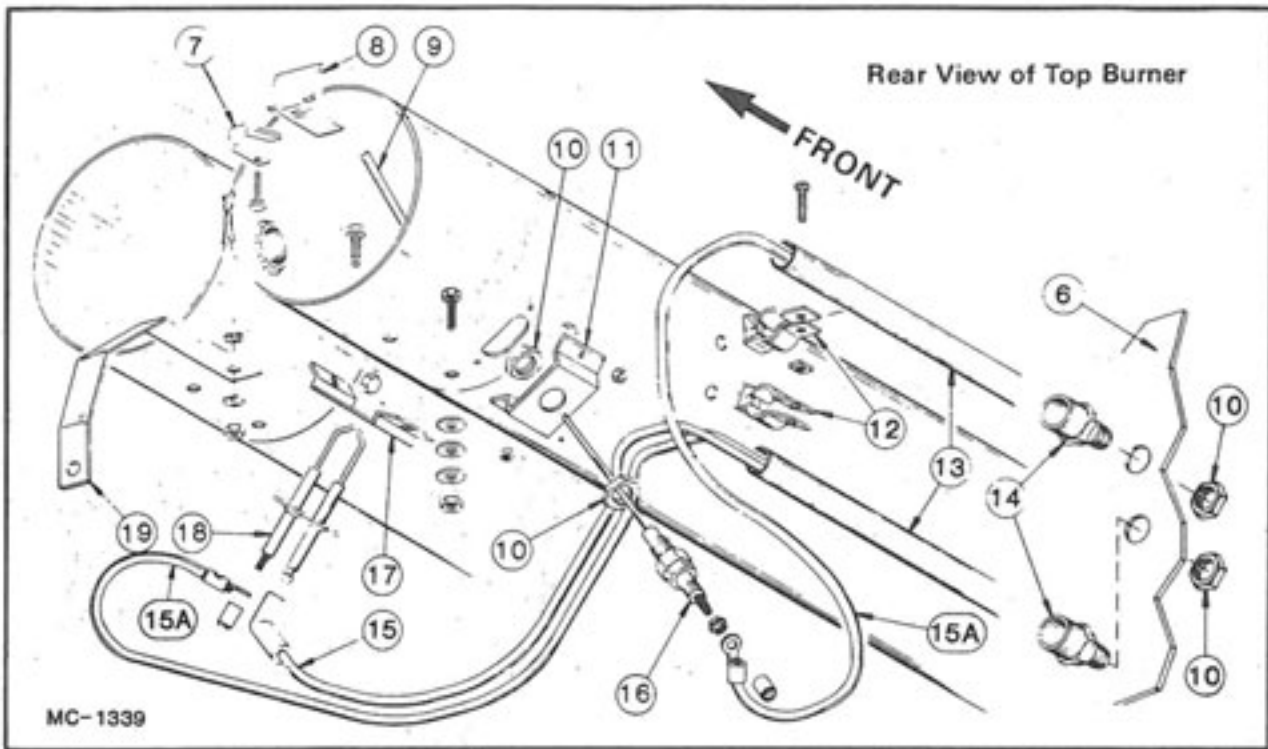

Venturi Burner

NOTE: Quantities shown are for one burner assembly.

Ref.	Part No.	Qty.	Description
1	128 8969	2	Burner Window Holder Clip
2	128 8968	1	Burner Window
3	128 4515	2	Air Adjuster Brkt.
4	128 3371	2	Air Adjuster Clamp Brkt.- Short (2-15/16")
	128 2008	2	Air Adjuster Clamp Brkt.- Long (3-9/16")
5	128 4488	2	Hand Hole Cover Plate
6	---	---	Front Fan Housing Panel
7	127 5201	1	Eddy Mtg. Strip
8	127 5200	1	Natural Gas Eddy
9	128 0197	1	Flame Ground Rod
10	121 6915	4	Locknut-1/2"
11	128 3007	1	Flame Sensing Probe Brkt.
12	121 6906	2	Pipe Clamp
13	128 5742	2	Igniter Line Support Tube
14	128 8061	2	PCV Male Adapter-1/2"
15	122 9003	3	Ignition & Remote Sensing Wire
15A	124 1079	2	Low Voltage Wire Assembly
16	124 6872	1	Flame Sensing Probe
17	128 2962	1	Electrode Mtg. Brkt.
18	128 6995	1	Style 2 Electrode
19	121 3007	1	Ground Strap
20	128 0108	2	Inlet Throttle
21	127 5700	2	Burner Nozzle (Natural Gas- 3/8" Orifice)
	128 5715	2	Burner Nozzle (LP Gas- 1/4" Orifice)
22	128 0112	2	Venturi Burner
23	128 4260	2	Burner Mtg. Strap
24	128 5401	6	Venturi Spacer
25	128 0137	1	Venturi Extension
26	---	---	Burner Deflector
	128 5310	1	17 3/8" (For 10HP fan ass'y.)
	127 5300	1	15 1/4" (For 15HP fan ass'y.)
	128 5308	1	12 3/4" (For 20HP fan ass'y.)
27	128 0141	1	Vaporizer Coil Anchor (LP Gas)
28	128 5306	1	Vaporizer Coil Anchor Clip (LP Gas)
29	128 0140	1	Vaporizer Coil (LP Gas)
30	128 4523	1	Burner Front Support-Right
	128 4524	1	Burner Front Support-Left
31	128 4941	1	Wire Support Brkt.
32	128 6989	3	Stand-Off Clip

Fans and Fan Drive

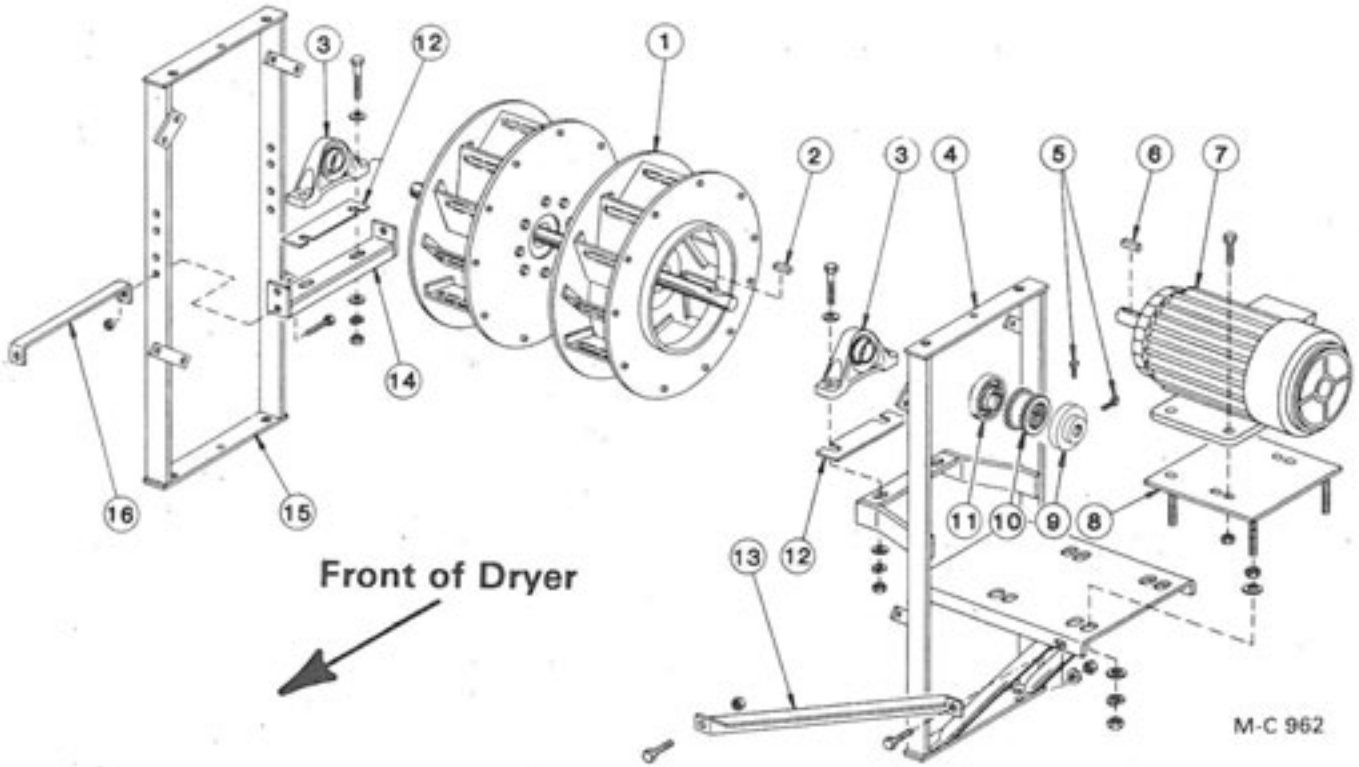

Fans and Fan Drive

Ref.	Part No.	Qty.	Description	Ref.	Part No.	Qty.	Description
1	---	-	Fan Ass'y - EM Models	9	128 6623	-	8-S Flange - 1 $\frac{1}{2}$ " Bore (10HP Motor)
	128 1288	1	10HP (Two 5HP fan wheels)		128 6604	-	8-S Flange - 1 $\frac{1}{2}$ " Bore (15 & 20HP Motors)
	128 1304	1	15HP (Two 7.5HP fan wheels)		128 6613	-	9-S Flange - 1 $\frac{1}{2}$ " Bore (30HP Motor)
	128 1266	1	20HP (Two 10HP fan wheels)	10	128 6606	-	Sleeve - Sureflex 8JE (10, 15 & 20HP Motors)
	128 1315	1	30HP (Two 15HP fan wheels)		128 6609	-	Sleeve - Sureflex (30HP Motor)
2	001 5150	-	Key - $\frac{1}{2}$ " x $\frac{3}{8}$ " x 2"	11	128 6622	-	8-S Flange - 2-3/16" Bore (10, 15, & 20HP Motors)
3	128 6022	-	Pillow Block Bearing 2-3/16" Bore		128 6620	-	9-S Flange - 2-3/16" (30HP Motor)
	000 8268	2	$\frac{5}{8}$ -11 x 3" Capscrew-Grd.5	12	128 2849	AR	Bearing Shim - 16 gauge
	000 8299	2	$\frac{5}{8}$ " SAE Flatwasher		128 2649	AR	Bearing Shim - 11 gauge
	000 8181	2	$\frac{5}{8}$ " Lockwasher	13	124 4213	-	Motor Mount Brace
	000 8164	2	$\frac{5}{8}$ -11 Hex Nut		000 8121	2	$\frac{5}{8}$ -16 x 1" Capscrew
4	128 0138	-	Motor Support - Upper Fan		000 8168	2	$\frac{5}{8}$ -16 Flanged Locknut
	128 0106	-	Motor Support - Lower Fan	14	128 0098	-	Bearing Support
	000 8121	8	$\frac{5}{8}$ -16 x 1" Capscrew		000 8138	3	$\frac{1}{2}$ -13 x 1 $\frac{1}{2}$ " Capscrew
	000 8168	8	$\frac{5}{8}$ -16 Flanged Locknut		000 8139	1	$\frac{1}{2}$ -13 x 1 $\frac{1}{4}$ " Capscrew
5	128 8130	-	$\frac{5}{8}$ -16 x 1" Sq. Hd. Cup Pt. Set Screw		000 8170	4	$\frac{1}{2}$ -13 Flanged Locknut
6	001 5124	-	Key - 5/16" x 2 $\frac{1}{2}$ " (10HP Motor)	15	128 0091	-	Fan Bearing Support
	001 5139	-	Key - $\frac{3}{8}$ " x 3" (15 & 20HP Motor)		000 8121	8	$\frac{5}{8}$ -16 x 1" Capscrew
7	201 6818	-	230/460V 10HP 3 \emptyset Motor		000 8168	8	$\frac{5}{8}$ -16 Flanged Locknut
	201 6819	-	230/460V 15HP 3 \emptyset Motor		000 8135	4	$\frac{1}{2}$ -13 x 1" Capscrew-Grd.5
	125 6934	-	230/460V 20HP 3 \emptyset Motor		000 8170	4	$\frac{1}{2}$ -13 Flanged Locknut
	128 6986	-	230/460V 30HP 3 \emptyset Motor	16	128 3452	-	Bearing Mt. Stiffener
	000 8139	4	$\frac{1}{2}$ -13 x 1 $\frac{1}{4}$ " Capscrew (15 & 20HP Motors)		000 8121	1	$\frac{5}{8}$ -16 x 1" Capscrew
	000 8170	4	$\frac{1}{2}$ -13 Flanged Locknut		000 8168	1	$\frac{5}{8}$ -16 Flanged Locknut
8	128 0167	-	Motor Mt. (10HP Motors)		000 8139	1	$\frac{1}{2}$ -13 x 1 $\frac{1}{4}$ " Capscrew
	121 0343	-	Motor Mt. (15 & 20HP Motors)		000 8170	1	$\frac{1}{2}$ -13 Flanged Locknut
	128 0090	-	Motor Mt. (30HP Motor)				
	000 8165	8	$\frac{3}{4}$ -10 Hex Nut				
	000 8177	8	$\frac{3}{4}$ " Flatwasher				
	000 8182	4	$\frac{3}{4}$ " Lockwasher				

NOTE: Fan assembly HP can be determined by measuring the width of the fan wheels.

- A. 2 $\frac{1}{2}$ " fan wheels - 5HP (Two fan wheels - 10HP)
- B. 3 $\frac{3}{8}$ " fan wheels - 7 $\frac{1}{2}$ HP (Two fan wheels - 15HP)
- C. 5 $\frac{1}{4}$ " fan wheels - 10HP (Two fan wheels - 20HP)
- D. 7-15/16" fan wheels - 15HP (Two fan wheels - 30HP)

Fan Housing

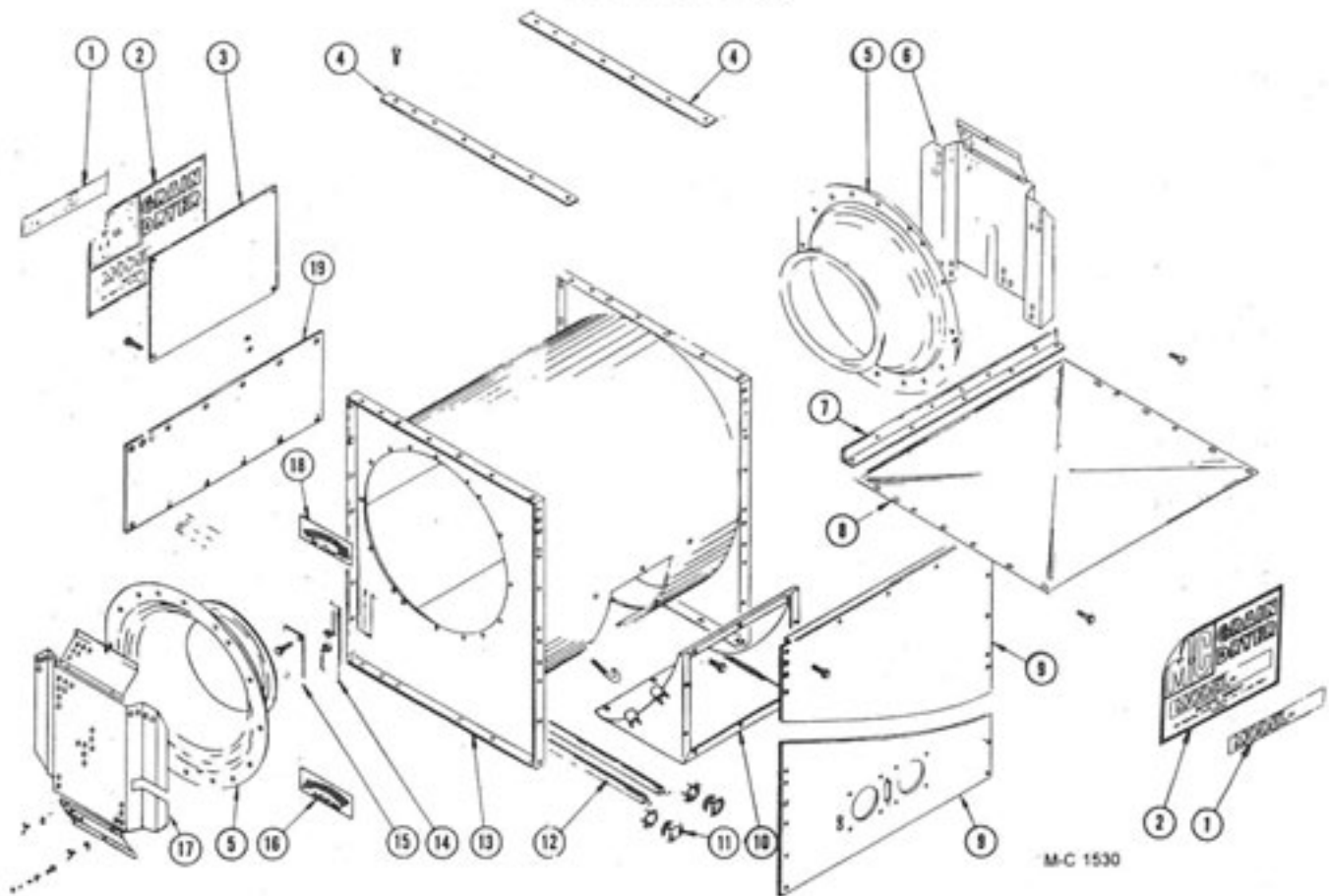

Ref.	Part No.	Qty.	Description
1	-----	—	Dryer Model Decal (Use w/ref. 2)
	128 8380	—	680
	128 8381	—	780
	128 8382	—	980
	128 8383	—	1080
	128 8384	—	1180
2	128 8331	2	Large Decal - Model 975 (See note 1)
3	128 2999	1	Decal Mt. Plate (at rear of dryer)
4	121 3566	2	Fan Hsg. Spacer Bar (Used between fan housings of middle and top modules on 1180)

Ref.	Part No.	Qty.	Description
	128 4552	1	Fan Hsg. Spacer Joiner - Left
	128 4554	1	Fan Hsg. Spacer - Left
	128 4850	1	Front Spacer Panel
5	128 5724	2	Air Intake Spinning
	000 8106	9	5/16-18x3/4" Capscrew
	000 8109	9	5/16-18x1 1/4" Capscrew
	000 8173	9	5/16" Flatwasher
	000 8169	18	5/16-18 Flanged Locknut -
6	122 9008	1	3/4 Fan Guard Kit
7	128 2757	1	Fan Hsg. Support
8	124 4834	1	Fan Hsg. Top Cover
9	128 0303	1	Front Panel (For 8' module only)
	128 0302	1	Front Panel (For 5' module only)
	128 0320	1	Front Panel (for 8' base module only)

NOTE 1: This decal is imprinted "Model 975." For other models, order one of 128 8331 and one of ref. 1 to be placed over "Model 975."

Continued on next page.

Fan Housing

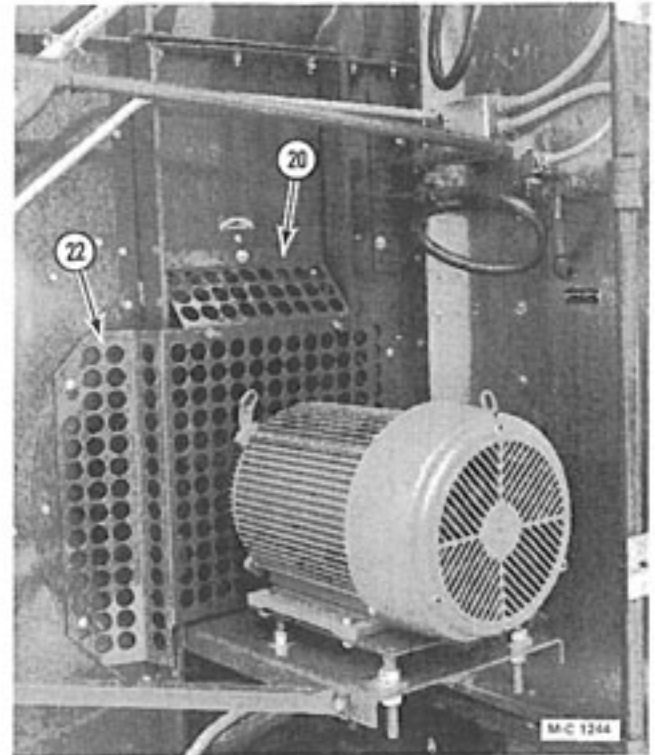
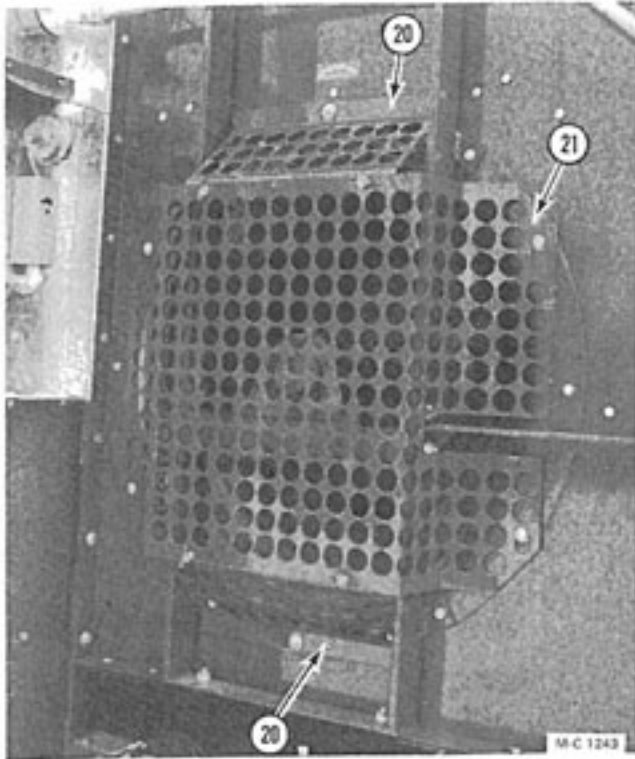

Ref.	Part No.	Qty.	Description
10	128 0142	1	Burner Transition
	120 8130	4	$\frac{3}{8}$ -16 x 2" "J" Bolt
	000 8119	3	$\frac{3}{8}$ -16 x $\frac{3}{4}$ " Capscrew
	000 8168	7	$\frac{3}{8}$ -16 Flanged Locknut
11	128 6929	2	Two Piece Connector - 1"
12	128 5746	2	Probe Tube
13	128 0127	1	Centrifugal Fan Hsg.
14	128 0086	1	Vaporizer Mt. Plate (LP Gas)
15	128 4940	1	Vaporizer Hole Cover (Nat. Gas)
16	121 8301	1	Counterclockwise Arrow Decal
17	122 9007	3	Full Fan Guard Kit
18	128 8322	1	Clockwise Arrow Decal
19	124 2857	1	Seal Panel Between Fan Hsgs.
20	124 4829	2	Fan Guard Extension - Full
21	124 4826	1	Full Fan Guard
22	124 4827	1	$\frac{3}{4}$ Fan Guard

Fan Housing

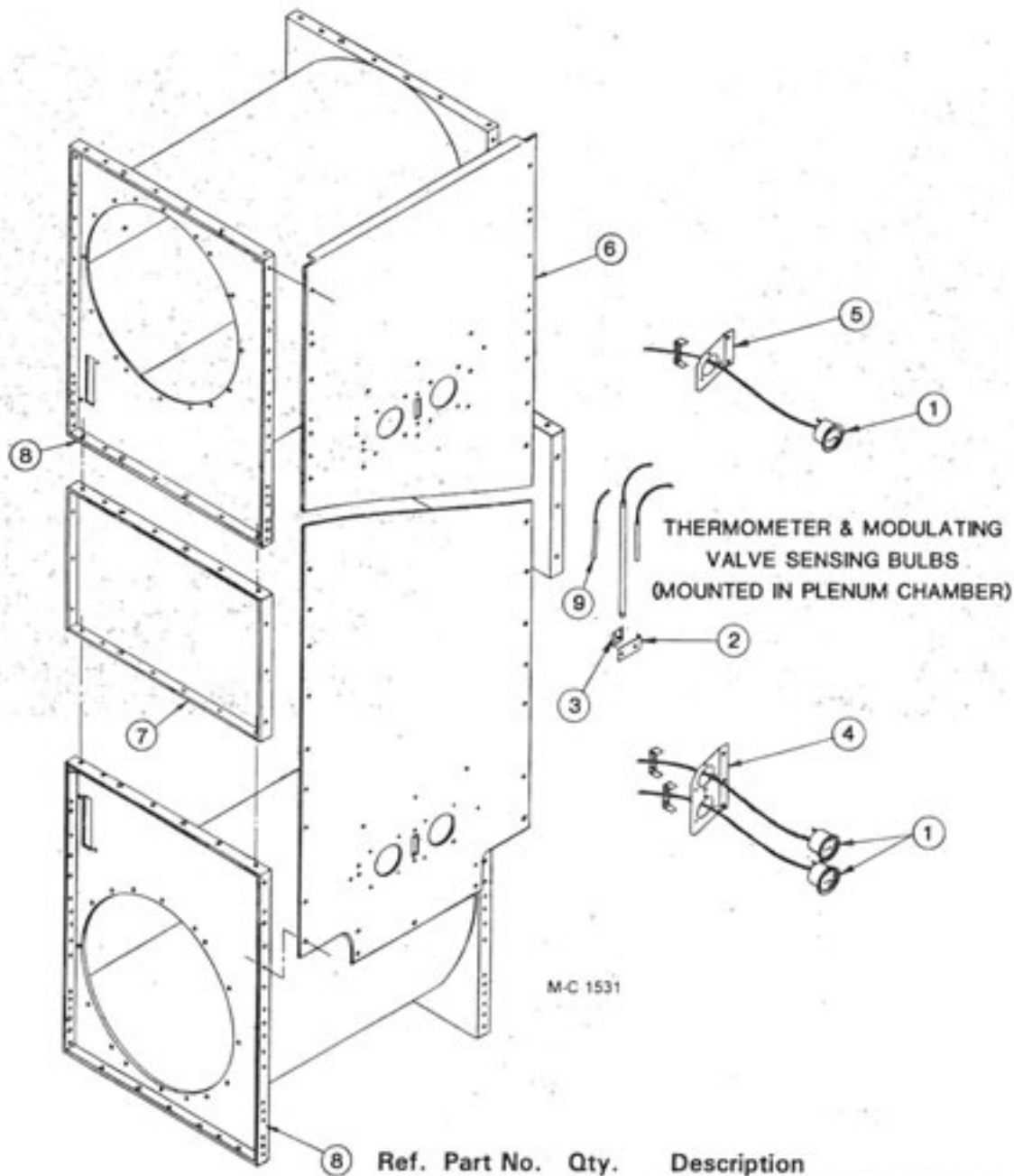

Ref.	Part No.	Qty.	Description
1	128 8983	-	Thermometer - 15' Capillary (Mnt. Brkt. included)
2	121 2883	1	Thermometer Sensing Bulb Brkt.
3	121 2882	1	Thermometer Sensing Bulb Clip
4	124 4815	1	Thermometer Mnt. Plate (Double)
5	124 4824	1	Thermometer Mnt. Plate (Single)
6	128 0320	1	Front Panel (For 8' Base Module)
	128 0302	1	Front Panel (For 8' Upper Module)
7	124 4428	2	Fan Housing Support Spacer
8	128 0127	2	Centrifugal Fan Housing
9	124 6961	-	Temperature Probe 180"
	124 6962	-	Temperature Probe 300"
	124 6971	-	Temperature Probe 420"

Fan Housing

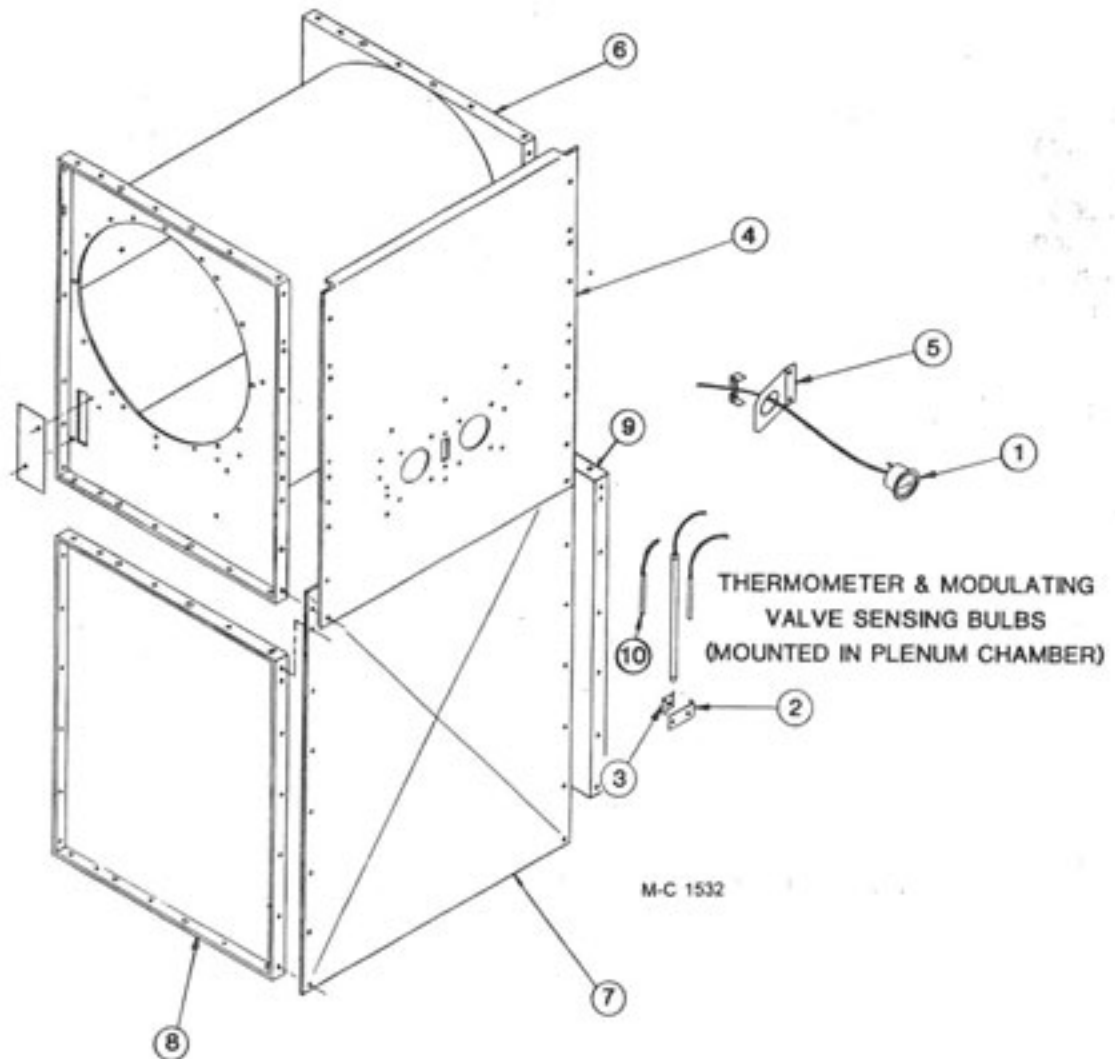

Ref.	Part No.	Qty.	Description
------	----------	------	-------------

1	128 8983	-	Thermometer - 15' Capillary (Mnt. Brkt. included)
2	121 2883	1	Thermometer Sensing Bulb Brkt.
3	121 2882	1	Thermometer Sensing Bulb Clip
4	128 0302	1	Front Panel (For 8' Upper Module)
5	124 4824	1	Thermometer Mnt. Plate (Single)
6	128 0127	1	Centrifugal Fan Housing
7	128 4974	1	Front Fan Housing Cover
8	128 4575	1	Fan Housing Side - Right
9	128 4576	1	Fan Housing Side - Left
10	124 6961	-	Temperature Probe 180°
	124 6962	-	Temperature Probe 300°
	124 6971	-	Temperature Probe 420°

LP Gas Manifold Low Fire Piping

Ref.	Part No.	Qty.	Description
1	127 8132	1	3/8" x 1/4" Reducing Bushing
2	121 8056	2	1/4" Std. Close Nipple
3	121 8039	2	1/4" Std. Street Elbow - 90°
4	120 8038	4	1/4" Std. Elbow - 90°
5	129 8039	4	1/4" x 1 1/4" Std. Nipple
6	120 8040	2	1/4" Std. Union
7	120 8026	2	1/4" x 2" Std. Nipple
8	120 8037	1	1/4" Std. Tee
9	120 7002	1	Pressure Gauge
10	120 8019	1	1/4" x 1 1/2" Std. Nipple
11	121 8030	2	3/8" x 1/4" Reducing Bushing
12	121 7002	1	3/4" Solenoid Valve
13	122 7035	1	Repair Kit for Ref. 12
	122 7001	1	Coil for Ref. 12

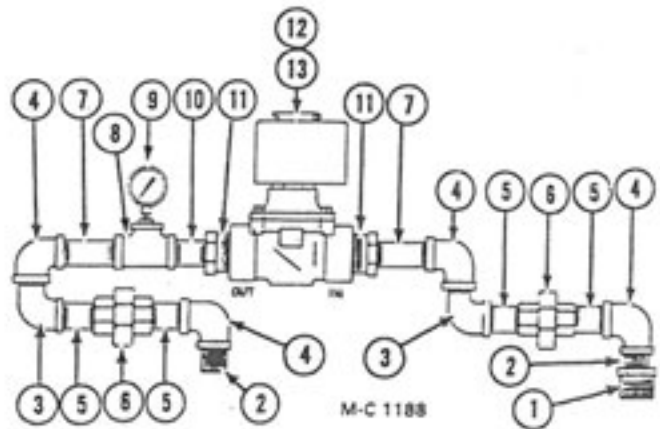

Natural Gas Low Fire Pipe Assembly

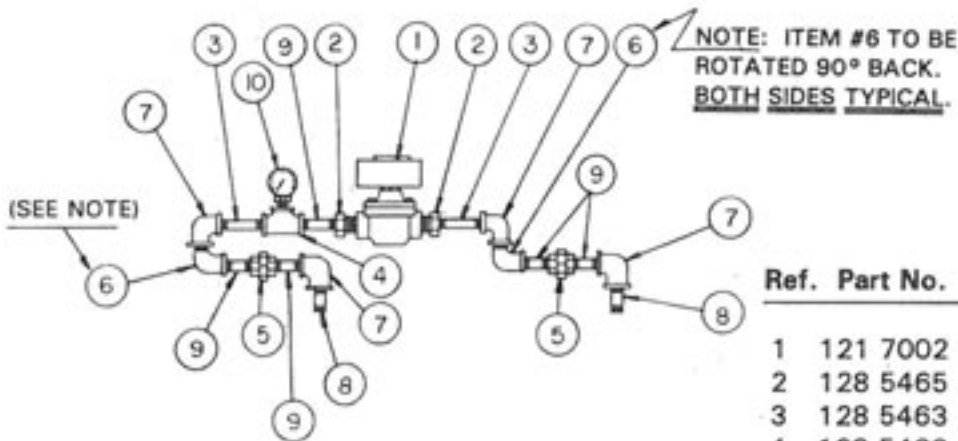

M-C 1550

Ref.	Part No.	Qty.	Description
1	121 7002	1	3/4" Solenoid Valve
2	128 5465	2	3/8" x 3/8" Hex. Bushing
3	128 5463	2	3/8" x 2" Nipple
4	128 5466	1	3/8" Tee
5	128 5469	2	3/8" Union
6	128 5467	2	3/8" 90° Street Elbow
7	128 5468	4	3/8" 90° Elbow
8	128 5464	2	3/8" Close Nipple
9	128 5462	5	3/8" x 1 1/2" Nipple
10	120 7002	1	Pressure Gauge

Safety Control Fire Alarm w/Safety Shut-Off Valve (Optional)

NOTE: LP Gas piping is shown. Natural Gas piping to be supplied by customer. Natural Gas manual reset valve is shown under ref. 10.

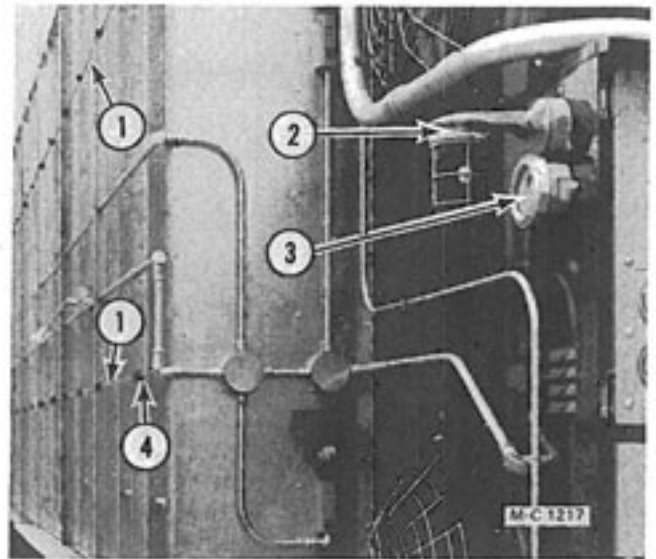

Ref.	Part No.	Qty.	Description
1	121 6956	—	Linear Limit Control (138")
	128 6850	—	Linear Limit Control (92")
	127 5713	—	Linear Tubing (93")
	127 5712	—	Linear Tubing (140")
	121 6893	—	Strain Relief Connector
2	123 6854	1	Light Fixture Complete
	123 6898	1	Red Glass Globe
	125 6823	1	100W Rough Service Bulb
3	123 6868	1	Horn (Alarm Buzzer)
4	128 2643	—	Bracket
	125 6900	—	½" Bushing
5	121 7026	1	Inlet Hose - 1"
6	128 8012	1	Hand Valve - 1"
7	125 8030	2	1" Close Extra Hvy. Nipple
8	125 8095	1	1" Strainer
9	125 8028	1	1" 90° Extra Hvy. Street Elbow
10	123 7027	1	1" Manual Reset Valve - LP Gas
	123 7028	1	2" Manual Reset Valve - Natural Gas
11	124 4225	1	Manual Reset Valve Brkt.
	001 8135	2	¾-16 x 1" Capscrew - Grd. 5
	000 8168	2	¾-16 Flanged Locknut
12	123 8110	2	5/16-18 x 1¾" "U" Bolt
	000 8169	2	5/16-18 Flanged Locknut
13	125 8017	1	1" x 5" Extra Hvy. Nipple
14	125 8031	1	1" Extra Hvy. Union
15	128 8042	1	1" x 34½" Extra Hvy. Nipple
16	125 8026	3	1" x 90° Extra Hvy. Elbow
17	128 5411	2	1" x 15" Extra Hvy. Nipple
18	125 8025	1	1" x 12" Extra Hvy. Nipple
19	125 8018	2	1" x 1" x ½" Extra Hvy. Tee
20	121 8081	1	½" Pipe Plug
21	128 8055	1	1" x 16½" Extra Hvy. Nipple
22	128 8047	1	1" Pipe Plug
23	128 5731	2	Fire Alarm Junc. Box
24	121 6808	4	125V Indicator Lamp Ass'y.

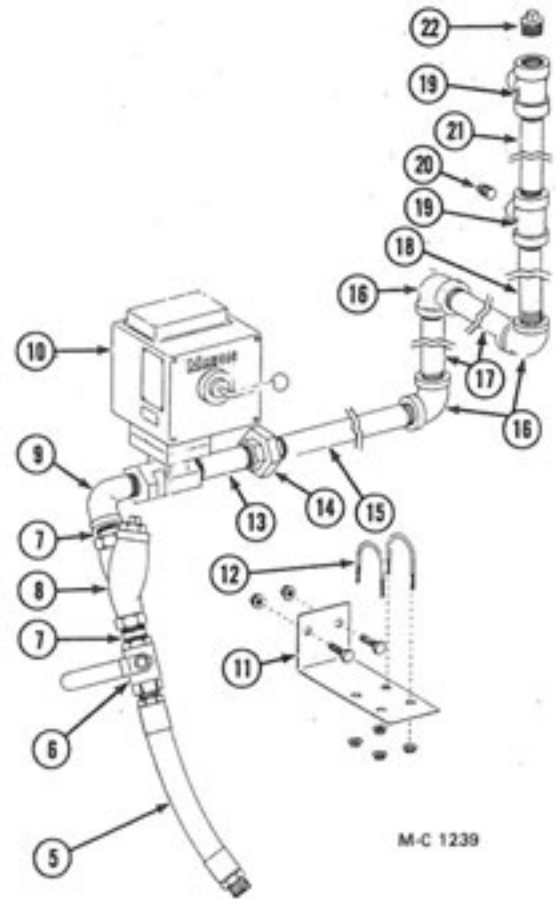

M-C 1239

LP and Natural Gas Manifolds

LP Gas Manifolds

Natural Gas Manifolds

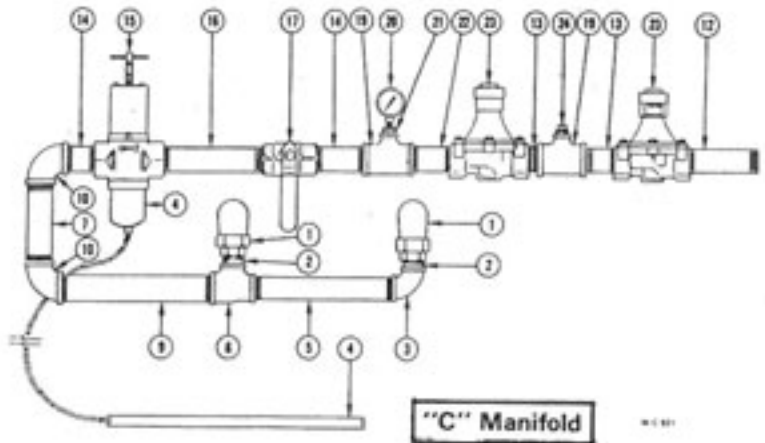
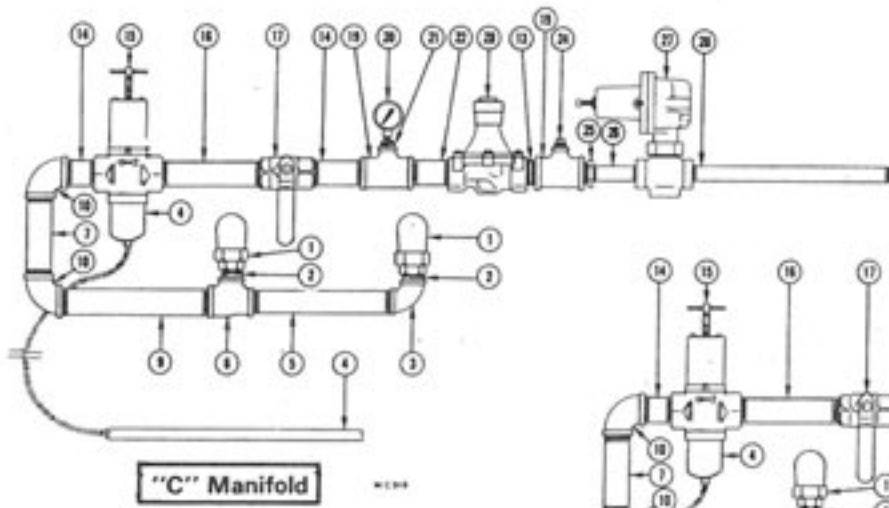
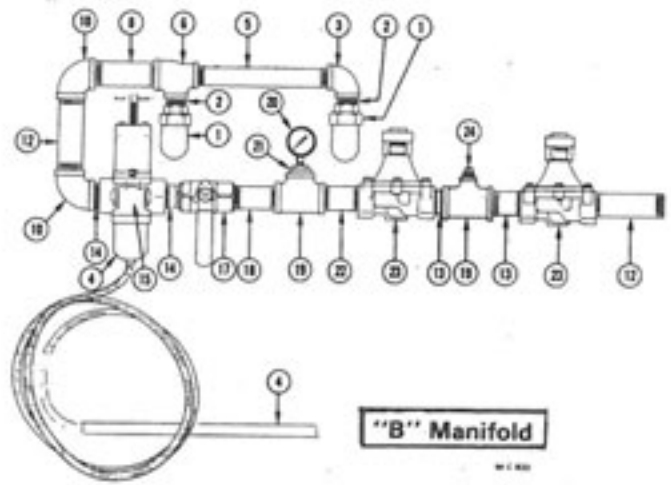
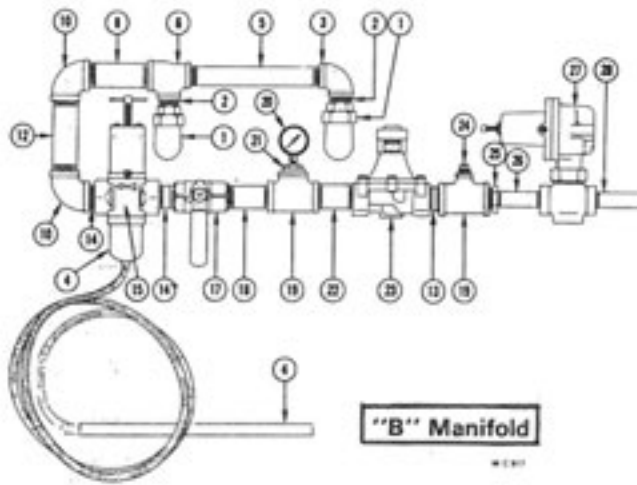
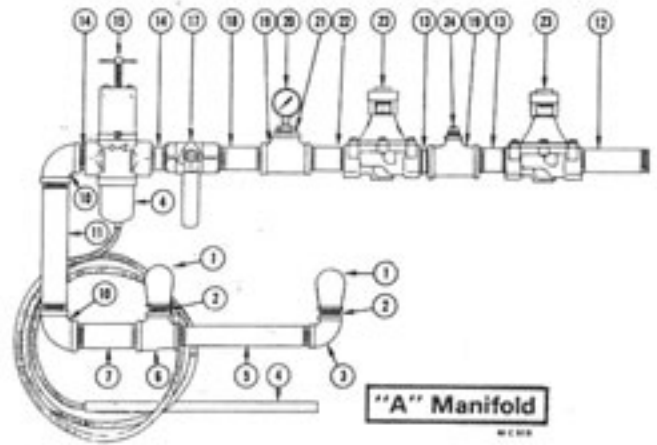
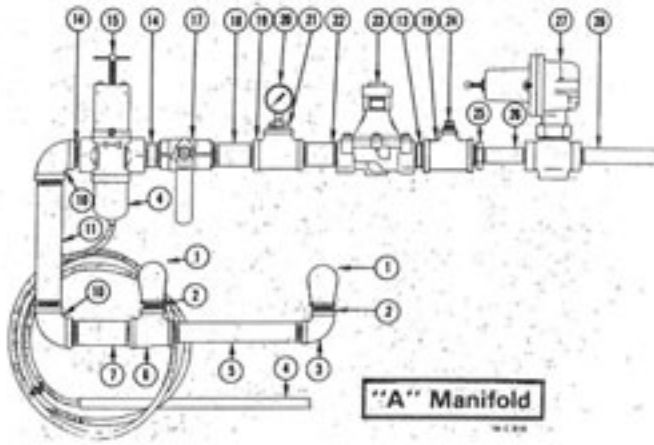

LP and Natural Gas Manifolds

Repair Kits and Parts for Modulating Valves, Solenoid Valves and LP Gas Pressure Regulators:

For Modulating Valves 123 7002 & 123 7024

122 9993 Seat Kit (Incl. stem, disc holder & diaphragm)

122 7006 Diaphragm

For 1¼" Solenoid Valve 128 7001

122 7034 Repair Kit (See note)

--- 4607 Coil

For ½" Solenoid Valve 125 7082

122 7039 Repair Kit (See note)

122 7001 Coil

NOTE: Kit includes all internal parts that would require replacement in normal service and installation instructions.

For LP Gas Pressure Regulator 128 7005

122 7043 - Diaphragm (Nitrile)

122 7044 - Disc Assembly

122 7045 - Control Spring (Yellow)

122 7046 - Stabilizer

122 7047 - Diaphragm Case O Ring

Gas Conversion and Burner Kits:

Gas Conversion Kits

128 9018 - LP to Natural Gas Conversion

One Burner

127 9148 - Natural Gas to LP Gas Conversion

One Burner

Burner Kit

127 9000 - Extra Burner - LP Gas

127 9004 - Extra Burner - Natural Gas

Ref.	Part No.	Description
1	128 8029	1" Std. Union Elbow-90°
2	128 8013	1" Std. Close Nipple
3	128 8016	1" Std. Elbow - 90°
4	122 7023	Power Element 90°-210°F (15' Capillary) Code "B"
	122 7036	Power Element 140°-250°F (15' Capillary) Code "D"
		Optional
		Standard
5	128 8058	1" x 10½" Std. Nipple
6	128 8007	1¼" x 1" x 1" Std. Tee
7	127 8016	1¼" x 5½" Std. Nipple
8	123 8046	1¼" x 7½" Std. Nipple
9	128 8065	1¼" x 11" Std. Nipple
10	123 8051	1¼" Std. Elbow - 90°
11	127 8021	1¼" x 9½" Std. Nipple
12	123 8073	1¼" x 6½" Std. Nipple
13	123 8069	1¼" Std. Close Nipple
14	123 8045	1¼" x 2½" Std. Nipple
15	123 7024	1¼" Modulating Valve w/ 140° 250°F Power Element
16	129 8033	1¼" x 8½" Std. Nipple
17	123 7003	1¼" Main Hand Valve
18	128 8024	1¼" x 5 Std. Nipple
19	127 8131	1¼" x 1¼" x ¾" Std. Tee
20	120 7002	Pressure Gauge
21	127 8132	¾" to ¼" Reducing Bushing
22	128 8003	1¼" x 3½" Std. Nipple
23	128 7001	1¼" Solenoid Valve
24	001 8001	¾" Pipe Plug
25	123 8078	1¼" x ¾" Std. Reducing Bushing
26	121 8069	¾" x 3" Std. Nipple
27	128 7005	LP Gas Pressure Reg. (Replaces 121 7006)
28	128 8066	¾" x 8" Extra Hvy. Duty Nipple

Vaporizer to Manifold Pipe

Ref. Part No. Qty. Description

1	121 8091	1	3/4" x 7 Ex. Hvy. Nipple
2	121 8027	2	3/4" x 90° Ex. Hvy. Elbow
3	121 8006	2	3/4" x 2" Ex. Hvy. Nipple
4	121 8072	1	3/4" Union Ex. Hvy.
5	121 8058	1	3/4" x 2 1/2" Ex. Hvy. Nipple
6	121 8060	1	3/4" Dirt Strainer
7	128 5426	1	3/4" x 30 1/2" Ex. Hvy. Nipple
8	121 8032	1	3/4" x 1/2" Red. 90° El. Ex. Hvy.
9	121 8094	1	1/2" x 1 1/2" Ex. Hvy. Nipple
10	121 8022	1	1/2" Union Ex. Hvy.

Upper Base Burner Assembly

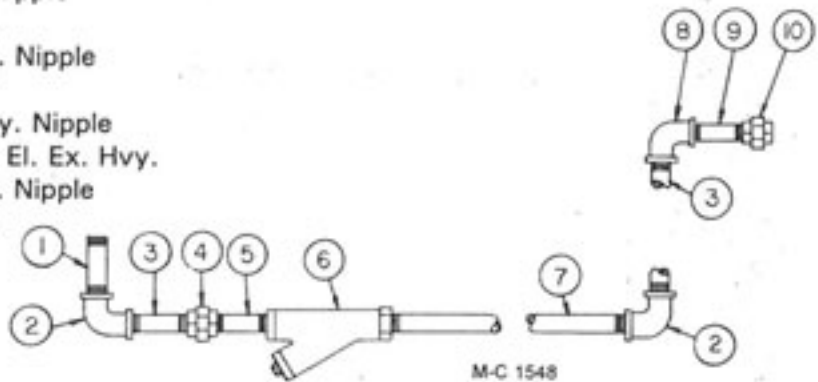

Ref. Part No. Qty. Description

1	121 8091	1	3/4" x 7 Ex. Hvy. Nipple
2	121 8027	2	3/4" x 90° Ex. Hvy. Elbow
3	121 8006	2	3/4" x 2" Ex. Hvy. Nipple
4	121 8072	1	3/4" Union Ex. Hvy.
5	121 8060	1	3/4" Dirt Strainer
6	128 5426	1	3/4" x 30 1/2" Ex. Hvy. Nipple
7	128 5427	1	3/4" x 14 1/2" Ex. Hvy. Nipple
8	121 8032	1	3/4" x 1/2" Red. 90° El. Ex. Hvy.
9	121 8094	1	1/2" x 1 1/2" Ex. Hvy. Nipple
10	121 8022	1	1/2" Union Ex. Hvy.

Lower Base Burner Assembly \ Upper Module Burner Assembly

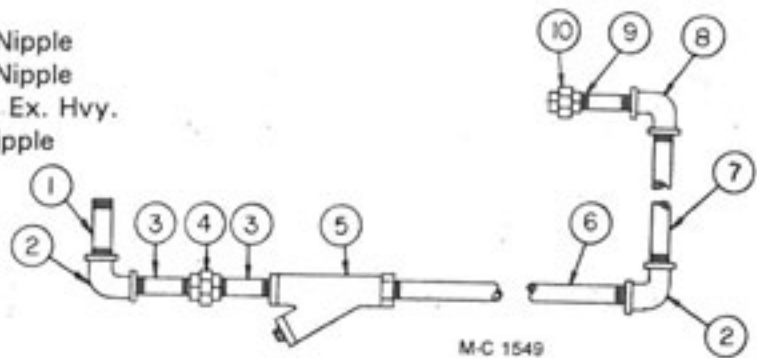

LP Gas Liquid Lines

Liquid Control Line

Ref. Part No. Description

1	121 8022	1/2" Extra Hvy. Union
2	128 8400	1/2" ID x 34" Hose w/Couplings
3	128 1820	3/8" Flexible Conduit
4	125 7082	1/2" Solenoid Valve
5	121 8094	1/2" x 1 1/2" Extra Hvy. Nipple
6	120 8035	1/2" Extra Hvy. Tee
7	121 7015	Hand Valve - 1/2"
8	121 8048	1/2" - 90° Std. Street Elbow
9	121 7014	Relief Valve Adapter
10	121 7013	Relief Valve

Solenoid Valve Repair Kit

The repair kit and coil for the 1/2" solenoid valve (ref. 4) is shown on page 31.

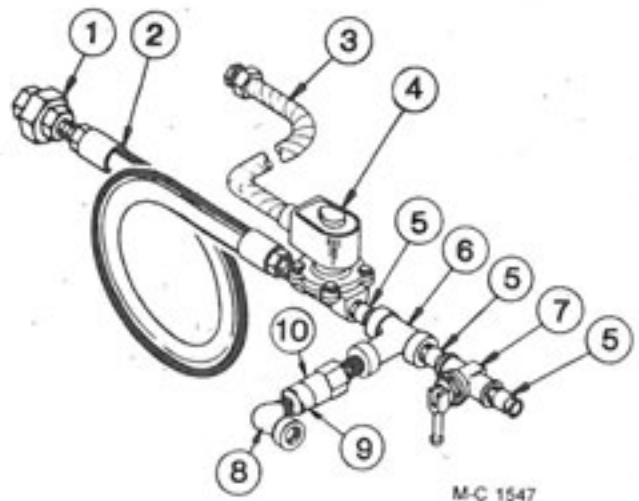

LP Gas Stand Pipe

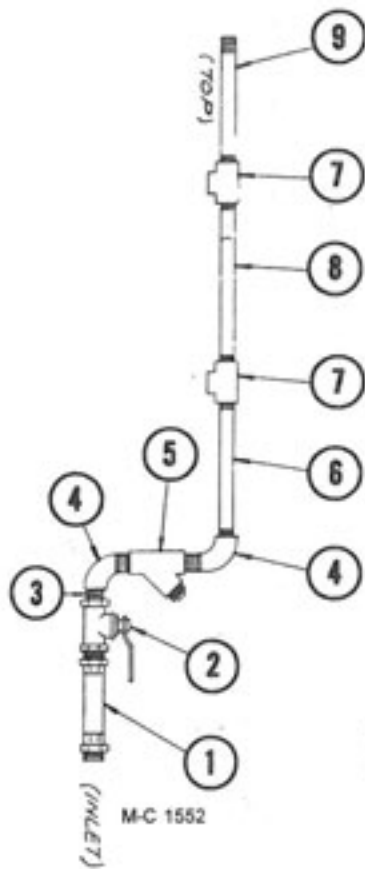

1080/1180 Base

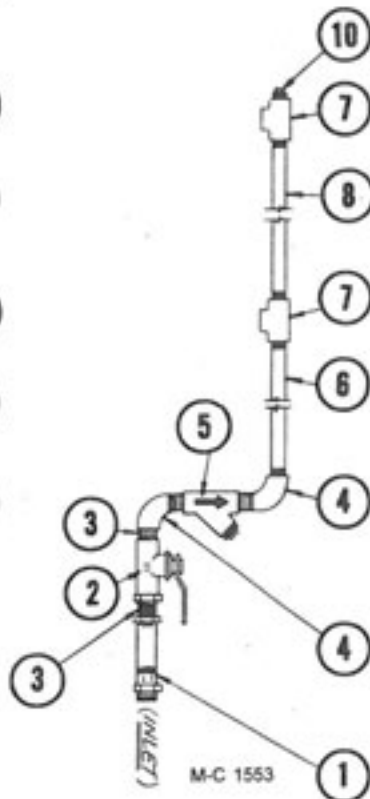

680/980

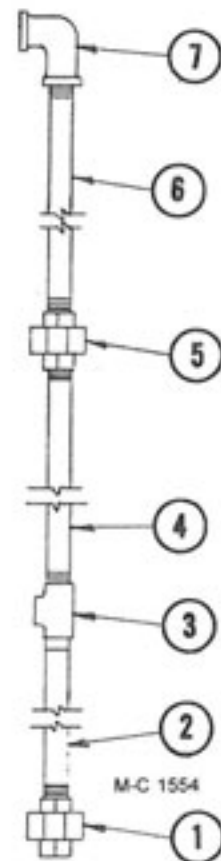

1080/1180 Upper Module

Ref.	Part No.	Qty.	Description
1	121 7026	1	1" Inlet Hose
2	128 8012	1	1" Hand Valve
3	125 8030	2	1" Close Nipple Ex. Hvy.
4	125 8028	2	1" Street El. 90° Ex. Hvy.
5	125 8095	1	1" Dirt Strainer
6	129 8003	1	1" x 28 3/4" Nipple Ex. Hvy.
7	125 8018	2	1" x 1" x 1/2" Tee Ex. Hvy.
8	128 5444	1	1" x 34" Nipple Ex. Hvy.
9	128 5445	1	1" x 38" Nipple Ex. Hvy.
10	128 8047	1	1" Pipe Plug

Ref.	Part No.	Qty.	Description
1	125 8031	1	1" Union Ex. Hvy.
2	128 5445	1	1" x 38" Nipple Ex. Hvy.
3	125 8018	1	1" x 1" x 1/2" Tee Ex. Hvy.
4	128 5447	1	1" x 54 1/2" Nipple Ex. Hvy.
5	125 8031	1	1" Union Ex. Hvy.
6	128 5447	1	1" x 54 1/2" Nipple Ex. Hvy.
7	121 8043	1	1" to 1/2" 90° El. Ex. Hvy.

Natural Gas Stand Pipe

680/980

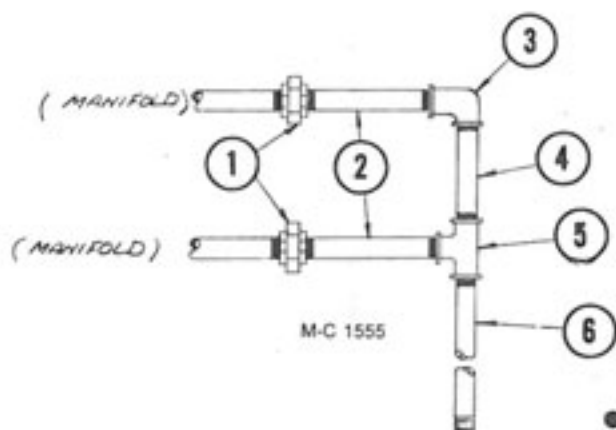

Ref. Part No.	Qty.	Description
1	2	1 1/4" Union Ex. Hvy.
2	2	1 1/4" x 2" Nipple Ex. Hvy.
3	1	1 1/4" 90° Elbow Ex. Hvy
4	1	1 1/4" x 9 1/2" Nipple Ex. Hvy.
5	1	1 1/4" Tee Ex. Hvy.
6	1	1 1/4" x 30" Nipple Ex. Hvy.

1080

Ref. Part No.	Qty.	Description
1	1	2" x 36 1/2" Nipple
2	3	2" x 2" x 1 1/4" Tee
3	1	2" x 10" Nipple
4	1	2" x 67 1/2" Nipple
5	1	2" x 46" Nipple
6	3	1 1/4" x 26" Nipple
7	3	1 1/4" Union
8	1	2" Pipe Plug
9	1	2" Union

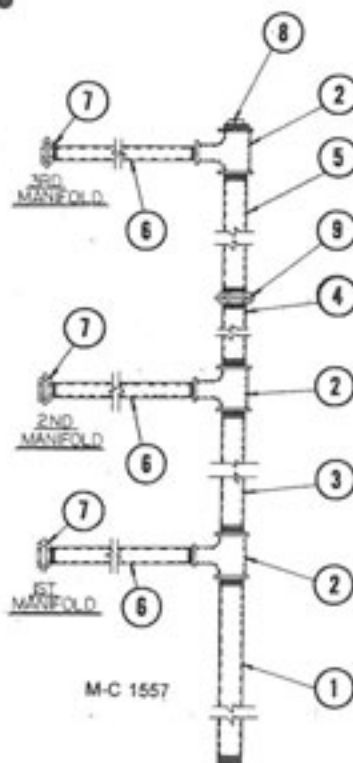

1180

Ref. Part No.	Qty.	Description
1	1	2" x 8" Nipple
2	3	2" Union
3	1	2" x 18" Nipple
4	1	2" 90° Elbow
5	1	2" x 36 1/2" Nipple
6	4	2" x 2" x 1 1/4" Tee
7	1	2" x 10" Nipple
8	1	2" x 67 1/2" Nipple
9	3	2" x 46" Nipple
10	4	1 1/4" x 26" Nipple
11	4	1 1/4" Union
12	1	2" Pipe Plug

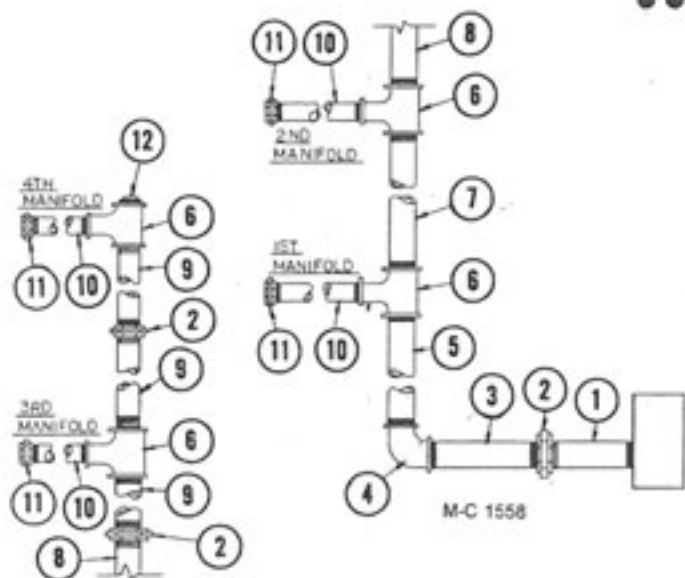

Moisture Control, Air Pressure and High Limit Switches

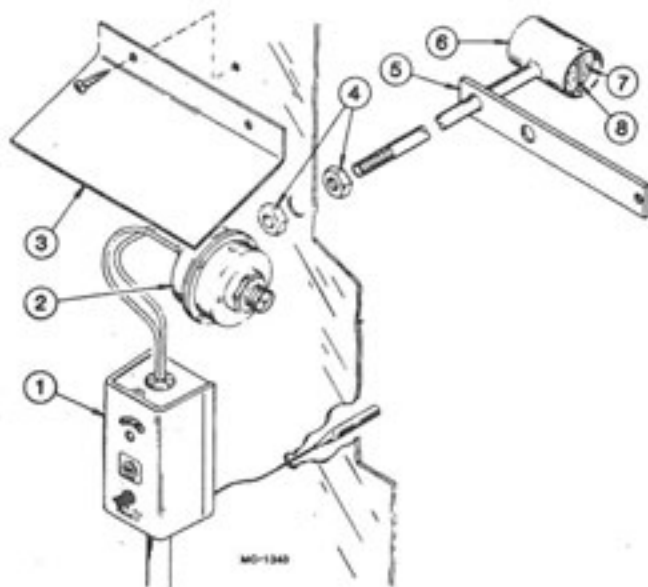

Air Pressure and High Limit Switches

Ref.	Part No.	Description
1	124 6934	High Limit Switch - Adjustable-Manual Reset
2	121 6849	Air Pressure Switch
3	121 2946	High Limit Switch Cover
4	121 8000	Pipe Locknut - 1/4"
5	121 2007	Air Pressure Tube Brkt.
6	121 0169	Air Pressure Tube
7	121 5716	Air Pressure Tube Filter
8	-----	Filter Retainer (Wire)

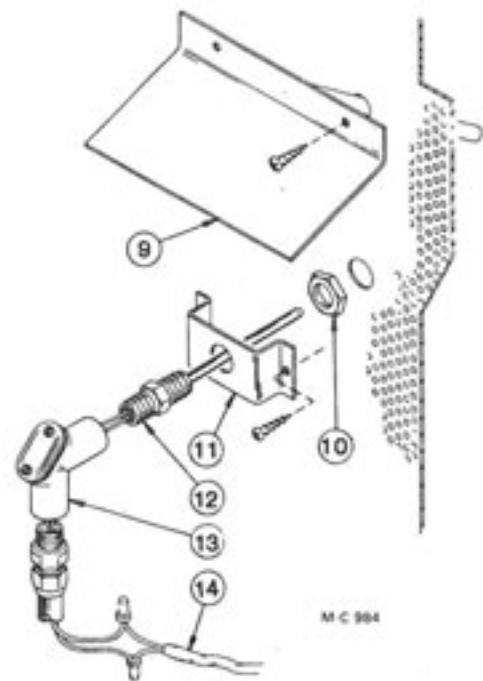

Moisture Control Probe

Ref.	Part No.	Description
9	121 0031	Moisture Control Shield
10	121 6915	Locknut - 1/2"
11	128 3007	Bracket
12	124 6893	Thermistor Sensor (Probe)
13	123 8089	1/2" Handy Ell
14	125 6908	18/2 PVC Cord w/Shield

Level Switch Assembly

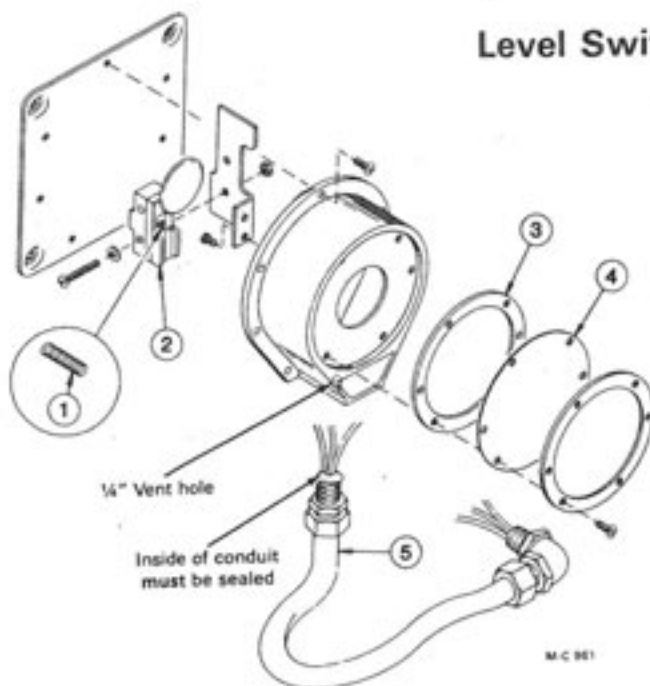

Ref.	Part No.	Qty.	Description
—	128 6992	1	Bin Level Indicator (Less ref. 5)
1	122 6847	1	Spring
2	122 6848	1	Microswitch Ass'y.
3	122 6850	1	Gasket
4	122 6849	1	Diaphragm (Teflon)
5	128 1995	1	Level Switch Wire Ass'y.

Motor Control Cabinet

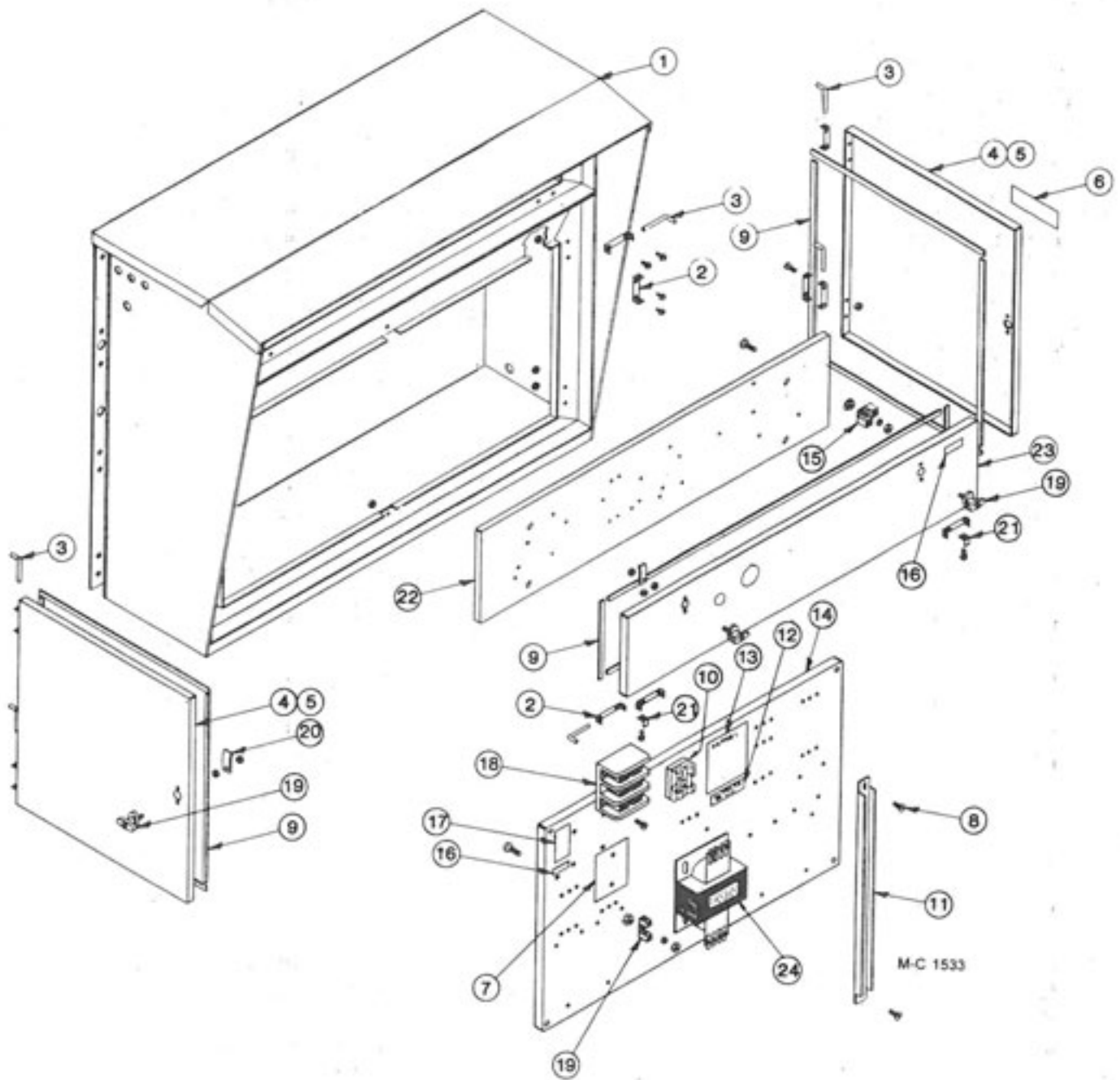

Motor Control Cabinet

Ref.	Part No.	Qty.	Description
1	128 0306	1	Motor Control Cabinet Weld.
2	128 2740	12	Door Hinge
3	128 5201	6	Hinge Pin
4	128 1329	2	Door Ass'y - Left & Right (Incl. ref. 2, 5 & 9)
5	128 4844	2	Door - Left & Right
6	121 8316	1	Dryer Warning Decal
7	128 5789	2	Insulator Sheet (460V - 575V)
8	000 8103	2	5/16-18 x 1/2" Truss Hd. Screw
	000 8169	2	5/16-18 Flanged Locknut
9	121 8966	-	Weather Stripping 1/4" x 3/4" (Specify ft. required)
10	121 6988	2	Fuse Holder - 460V & 575V
	203 6801	1	Double Fuse Block - 200/208V
11	128 4843	1	Door Jamb
12	123 8339	1	208 Volts Decal
	123 8336	1	230 Volts Decal
	123 8337	1	460 Volts Decal
	123 8338	1	575 Volts Decal
13	121 8315	1	Notice, Warranty Decal
14	124 4448	1	Component Mounting Panel
15	125 6918	2	Grounding Lug
16	128 8349	2	Ground Decal
17	128 8318	1	Splitter Block Voltage Decal
18	128 6957	1	Splitter Block - 1 & 3 Phase
19	124 1021	4	Door "T" Handle Ass'y (Incl. ref. 24 cam, keys and mtg. hdwe.) Lever type handle no longer available.
	128 8946	4	Door "T" Handle w/Keys (Less ref. 24 cam)
	122 8900	4	Door "T" Handle Key
20	128 3425	4	Door Latch Cam
21	128 2741	2	Stop Bracket
22	124 4806	1	Component Mounting Board
23	124 1130	1	Control Door Assembly
24	127 6829	1	Transformer (750VA)

Remote Cabinet Assembly

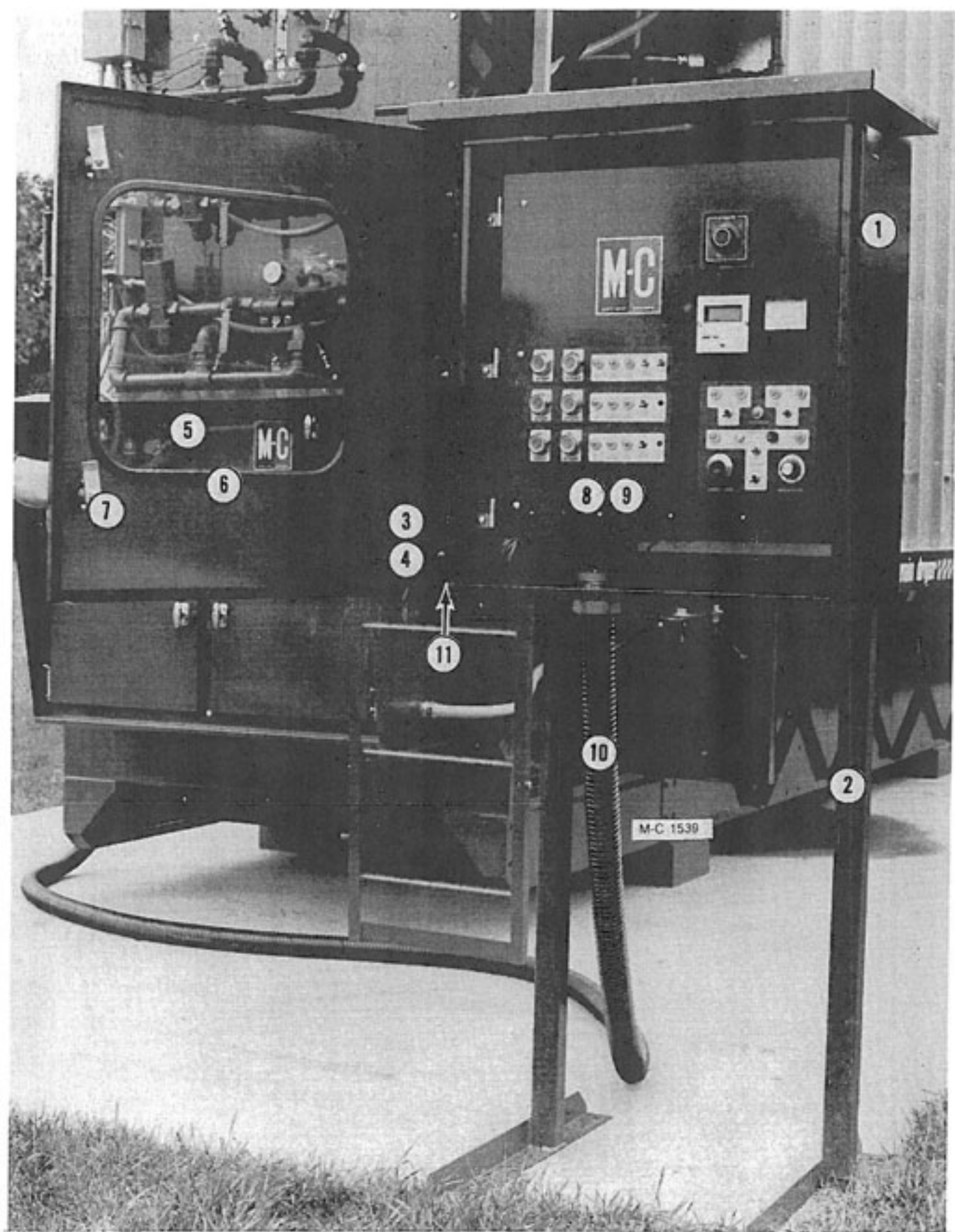

Remote Cabinet Assembly

Ref.	Part No.	Qty.	Description
1	128 0321	1	Cabinet Weldment
2	128 0323	2	Remote Cabinet Stands
3	124 1117	1	Remote Cabinet Door Assembly
4	124 4858	1	Cabinet Door Outer
5	128 4943	1	Control Cabinet Window
6	128 8603	7	Weather Strip
7	124 1021	2	Door "T" Handle Assembly
8	124 1118	1	2-Fan Inside Door Assembly
	124 1156	1	3-Fan Inside Door Assembly
	124 1168	1	4-Fan Inside Door Assembly
9	124 4854	1	2-Fan Control Door
	124 4859	1	3-Fan Control Door
	124 4860	1	4-Fan Control Door
10	124 1184	1	Standard Remote Cabinet Liquefite Assembly (without wire)
11	128 5829	1	Outer Door Hinge - 30"

Remote Cabinet Door Inside

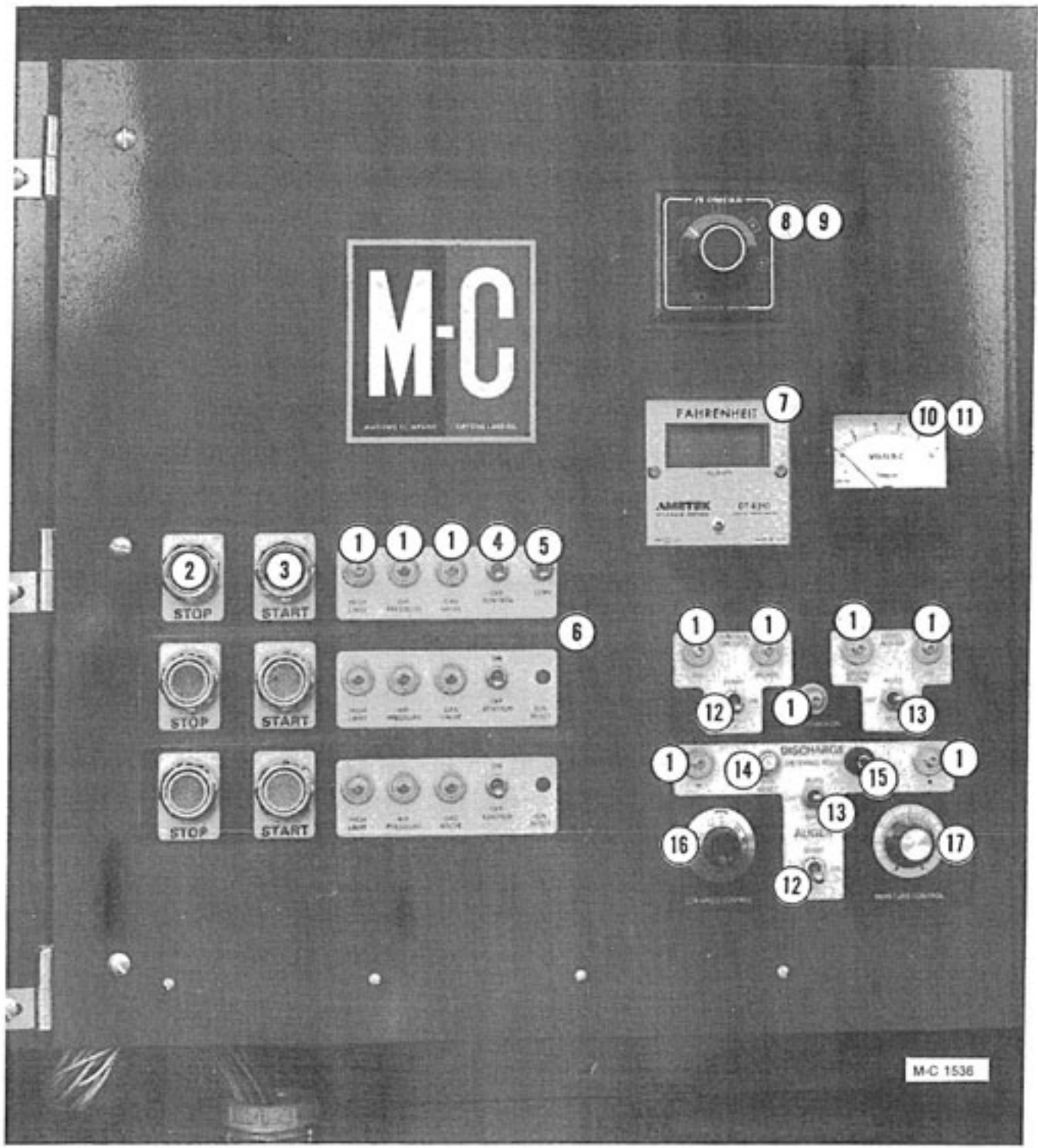

Remote Cabinet Door Inside

Ref.	Part No.	Qty.	Description
1	121 6808	-	125V Indicator Lamp Assembly
2	128 6845	-	Stop Button - Red
3	128 6844	-	Start Button - Black
4	121 6815	-	SPST On-Off Toggle Switch
5	124 6899	-	Hi/Low Toggle Switch
6	128 8358	-	Fan Control Bezel
7	124 6958	1	Digital Read-Out Meter
8	124 6959	1	Rotary Selector Switch-5
	124 6960	1	Rotary Selector Switch-8
9	124 6968	-	Extension Hook-Up Cable (not shown)
10	124 6936	1	Discharge Speed Meter
11	124 1081	1	Meter Resistor Assembly (not shown)
12	120 6827	2	Off-On-On Momentary Contact Toggle Switch
13	121 6807	2	On-Off-On Toggle Switch DPDT
14	124 6848	1	8 Amp Circuit Breaker (SCR Drive)
15	124 6938	1	Fuse Holder
	124 6937	1	1 Amp Fuse Slo-Blow
16	124 1089	1	SCR Drive Potentiometer (10 turn w/wire)
	124 6892	1	Multi Dial
17	124 6939	1	Moisture Control Potentiometer & Wire
	124 6941	1	Knob

Component Mounting Assembly

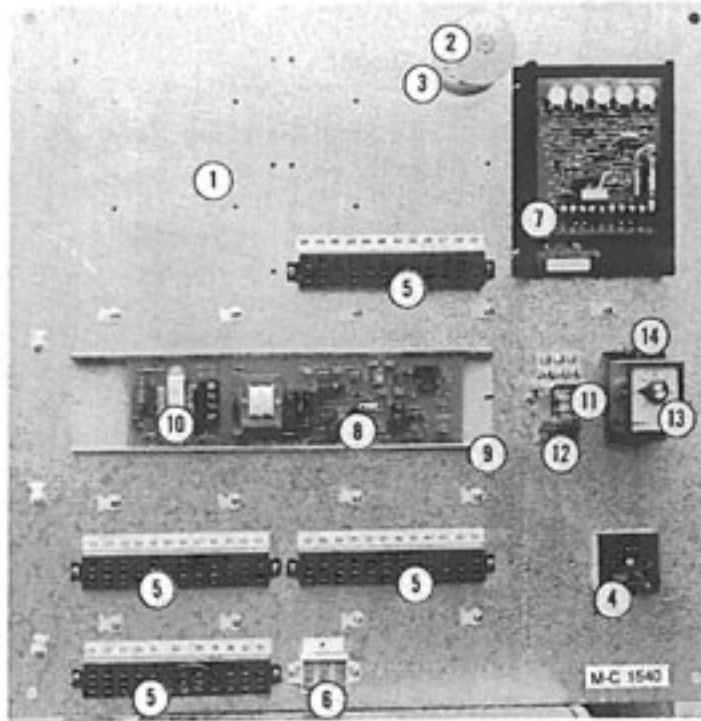

Ref.	Part No.	Description
1	124 2865	Component Mount Panel
2	124 6850	25 Watt Light Bulb
3	124 6841	Light Bulb Socket
4	124 6890	Adjustable Timer
5	124 6928	Terminal Block 12-Position
6	124 6929	Terminal Block 3-Position
7	124 6874	SCR Board (1/2 HP DC)
8	124 6957	Moisture Matic III (shown below)
9	128 5828	Snap Track
10	124 6966	8 DC Volt Power Supply
11	021 6809	Main Relay
12	021 6810	Relay Socket
13	021 6815	60 Minute Adjustable Timer
14	021 6816	Timer Socket
	125 6918	Ground Lug

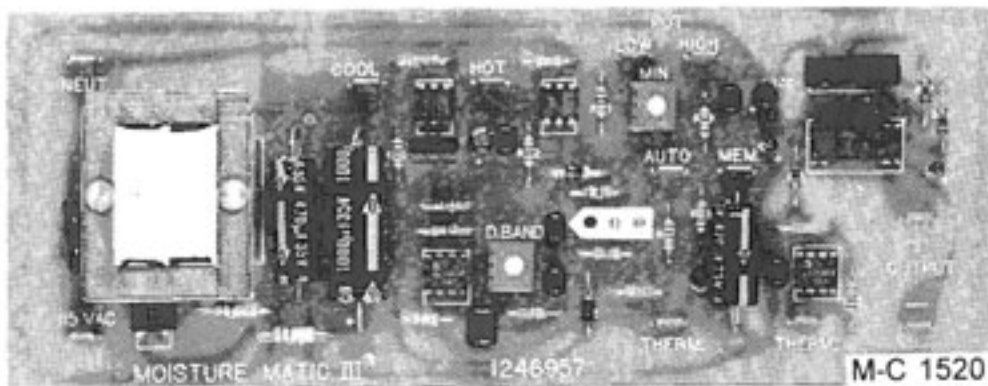

Electrical Components In 115V Control Cabinet

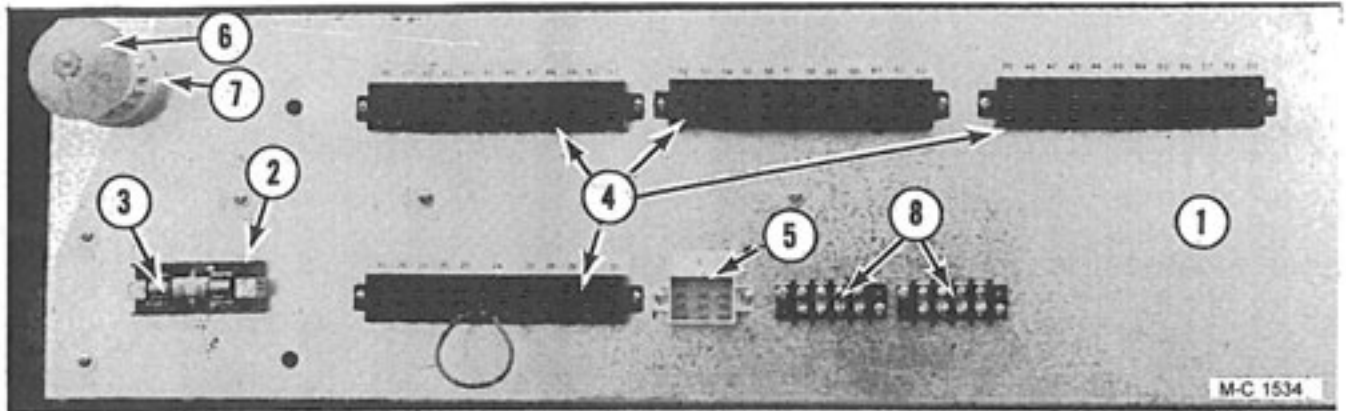

Ref.	Part No.	Description
1	124 4771	Component Mounting Board
2	128 6851	Fuse Holder
3	128 6967	10 Amp Fuse (NON-10)
4	124 6928	Terminal Block 12-Position
5	124 6929	Terminal Block 3-Position
6	124 6850	25 Watt Light
7	124 6841	Light Bulb Socket
8	124 6970	Terminal Block

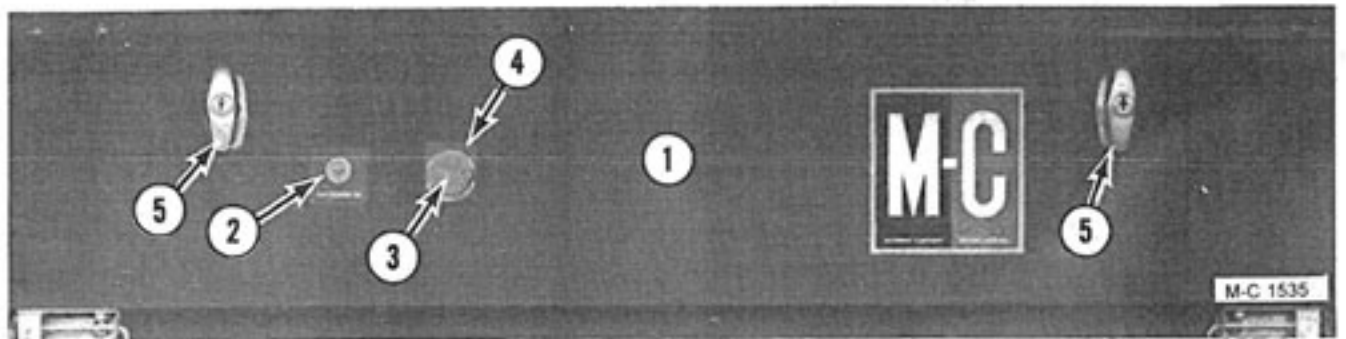

Ref.	Part No.	Description
1	124 4864	Control Door
2	121 6808	125V Indicator Lamp Assembly
3	124 6967	Palm Switch
4	128 8379	"Stop" Legend Plate
5	124 1021	Door "T" Handle Assembly

Ignition Board and Box

Ref.	Part No.	Qty.	Description
1	124 5705	1	Ignition Board
2	128 2938	1	Ignition Board Mt. Plate
3	124 6969	1	115V Ignition Board
4	124 1079	2	Low Voltage Wire Kit
5	122 9003	1	High Voltage Wire Kit
6	121 6815	1	SPST On-Off Toggle Switch
7	128 8377	1	Ignition Switch Decal

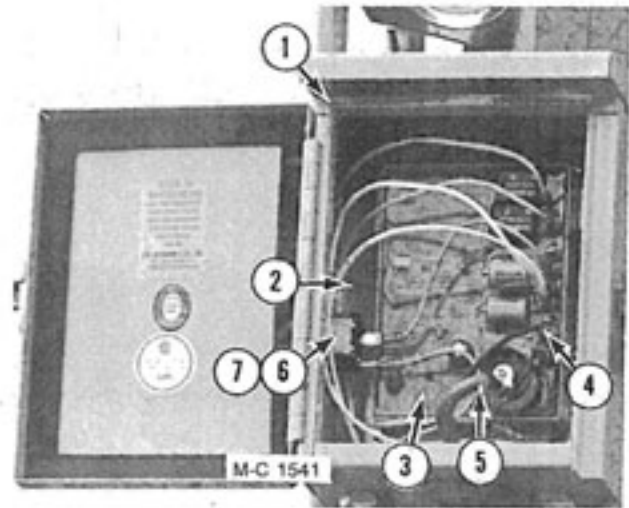

Ignition Board Wiring

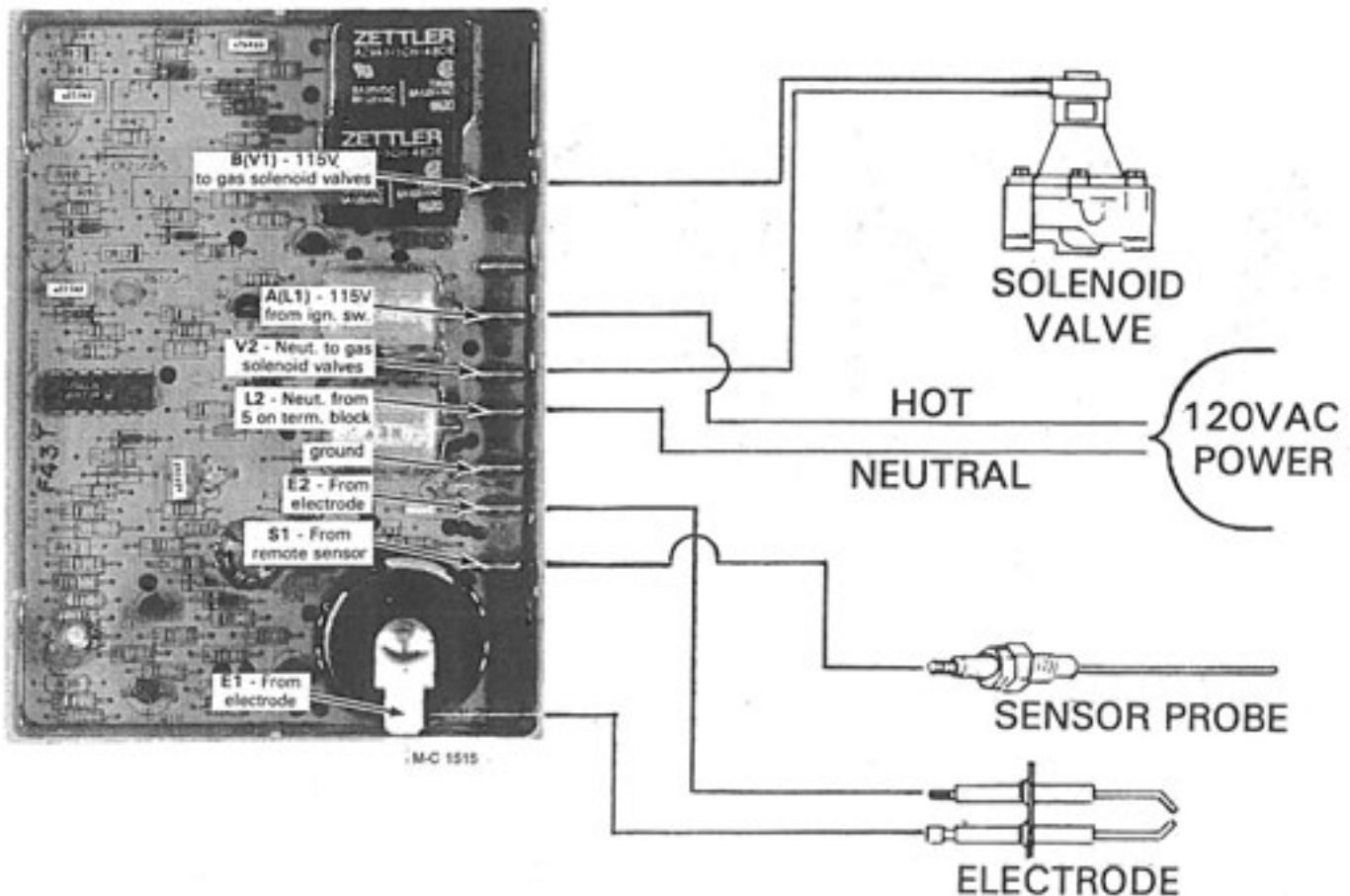

Peak

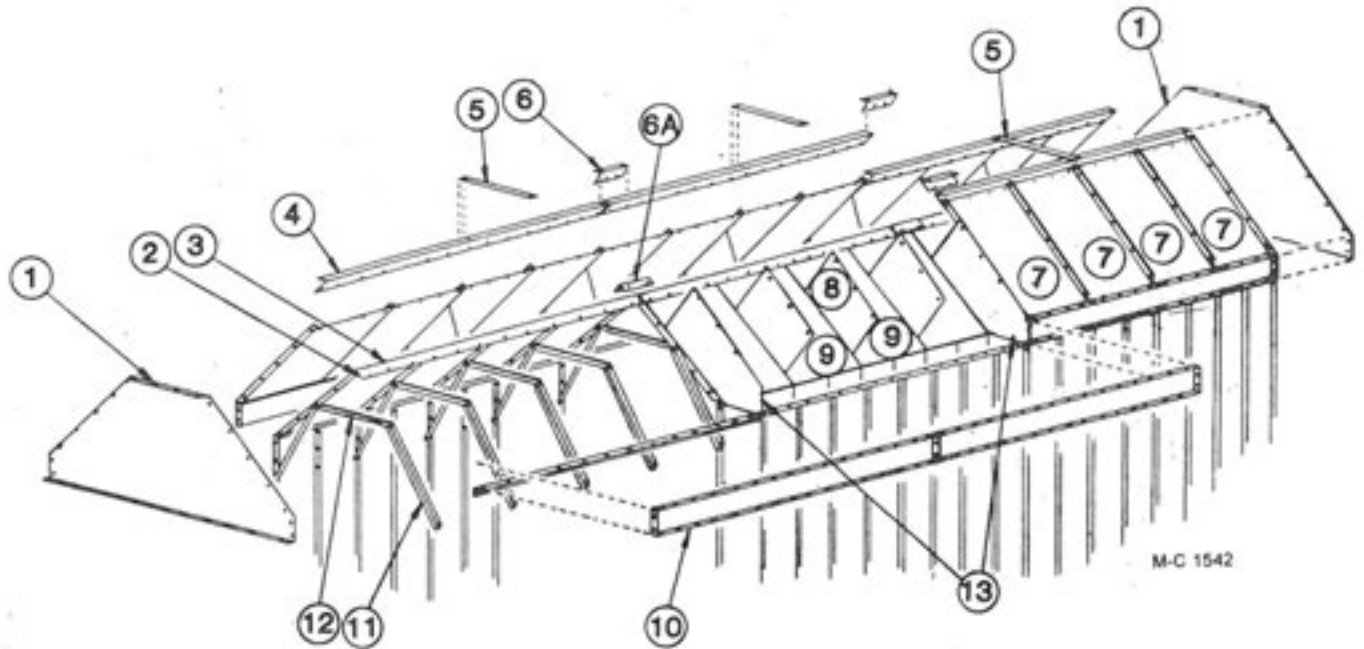

Ref.	Part No.	Qty (16')	Qty (24')	Description
1	129 2837	2	2	Peak Outer End Panel
2	128 2908	2	2	Peak Seal Angle - Early Production (Late Production, use ref. 6A)
3	128 2991	2	3	Peak Cap
4	128 2739	4	6	Hopper Mount Angle
5	129 2947	2	3	Stiffener Strap (28")
6	129 3070	2	4	Hopper Mount Angle Splice
6A	128 3075	1	2	Seal Angle
7	-----	-	-	Outer Peak Panel
	129 2002	16	24	Aluminum (Std.)
	129 2950	16	24	Small Seed Aluminum
8	129 2830	12	18	Stiffening Divider
9	-----	-	-	Inner Peak Panel
	129 2000	16	24	Galvanized (Std.)
	129 2949	16	24	Small Seed Solid (Galv.)
10	129 2833	4	6	Peak Channel
11	129 2001	14	22	Vertical Support Angle (29 1/2")
12	128 2012	7	11	Inner Peak Panel Cross Tie (31 1/4")
13	129 2840	2	4	Stiffening Divider

Hopper and Level Auger

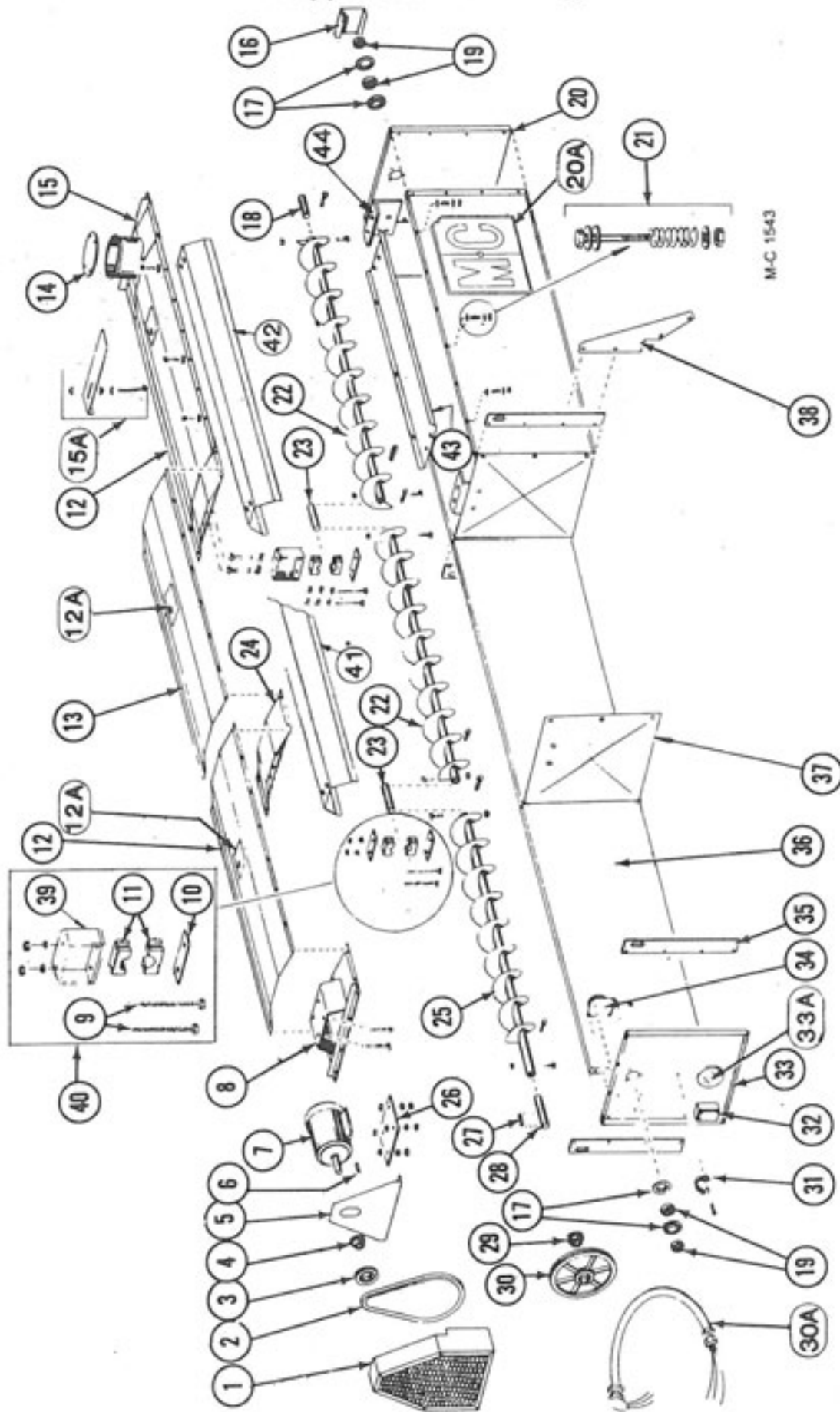

Hopper and Level Auger

Ref.	Part No.	Qty. (16')	Qty. (24')	Description
1	129 0003	1	1	Level Auger Guard
2	128 6103	1	1	2-3V/710 (banded belt) or 128 6104 in matched set of two
3	128 6207	1	1	3V/3.65 x 2 Grv.
4	128 6214	1	1	1-1/8" SH Bushing - For 3 HP & 5 HP motor (incl. capscrews & lock washers)
5	129 4944	1	1	Level Auger Guard Back
6	001 5112	1	-	Key-3/16" x 1 1/8" (1.5 HP motor)
	001 5114	1	1	Key-3/16" x 1 1/8" (2 HP motor)
	001 5119	-	1	Key-1/4" x 2" (3 HP motor)
7	128 6818	1	-	230/460V 3HP 3Ø Motor
	128 6815	-	1	230/460V 5HP 3Ø Motor
8	129 0001	1	1	Level Auger Motor Mt.
9	001 8287	2	4	3/8-16 x 3-3/4" Capscrew-Grd. 5
	001 8139	2	4	3/8" Lockwasher
	000 8162	8	16	3/8-16 Hex Nut
10	128,3415	2	4	Bearing Hanger Bar
11	128 6021	1	2	Wood Bearing - 1 1/4" (2 halves)

Ref.	Part No.	Qty. (16')	Qty. (24')	Description
12	129 2945	2	2	Hopper Cover - Front & Rear (76")
12A	128 8355	2	3	Warning Decal
13	129 2946	-	1	Hopper Cover - Center (83")
14	129 4204	1	1	Receiving Tube Cover
15	129 0002	1	1	Receiving Hopper
15A	129 4205	1	1	Flow Restrictor
	129 5703	1	1	Position & Locking Bolt
	000 8168	3	3	3/8-16 Flanged Locknut
16	129 4947	1	1	Stub Guard
17	001 6004	4	4	Bearing Flangette 1 1/4"
18	128 5052	1	1	Level Auger Rear Shaft (1 1/4" x 8")
19	001 6003	2	2	Bearing w/Lock Collar - 1 1/4"
20	129 2834	1	1	Upper End Panel - Rear
20A	121 8343	2	2	M-C Decal (26 1/2" x 23")
21	000 8101	12	18	1/4-20 x 2" Capscrew
	131 8708	12	18	Spring (5/8"OD x 1 3/4")
	000 8172	36	54	1/4" Flatwasher
	000 8210	12	18	1/4-20 Two-Way Locknut

Hopper and Level Auger

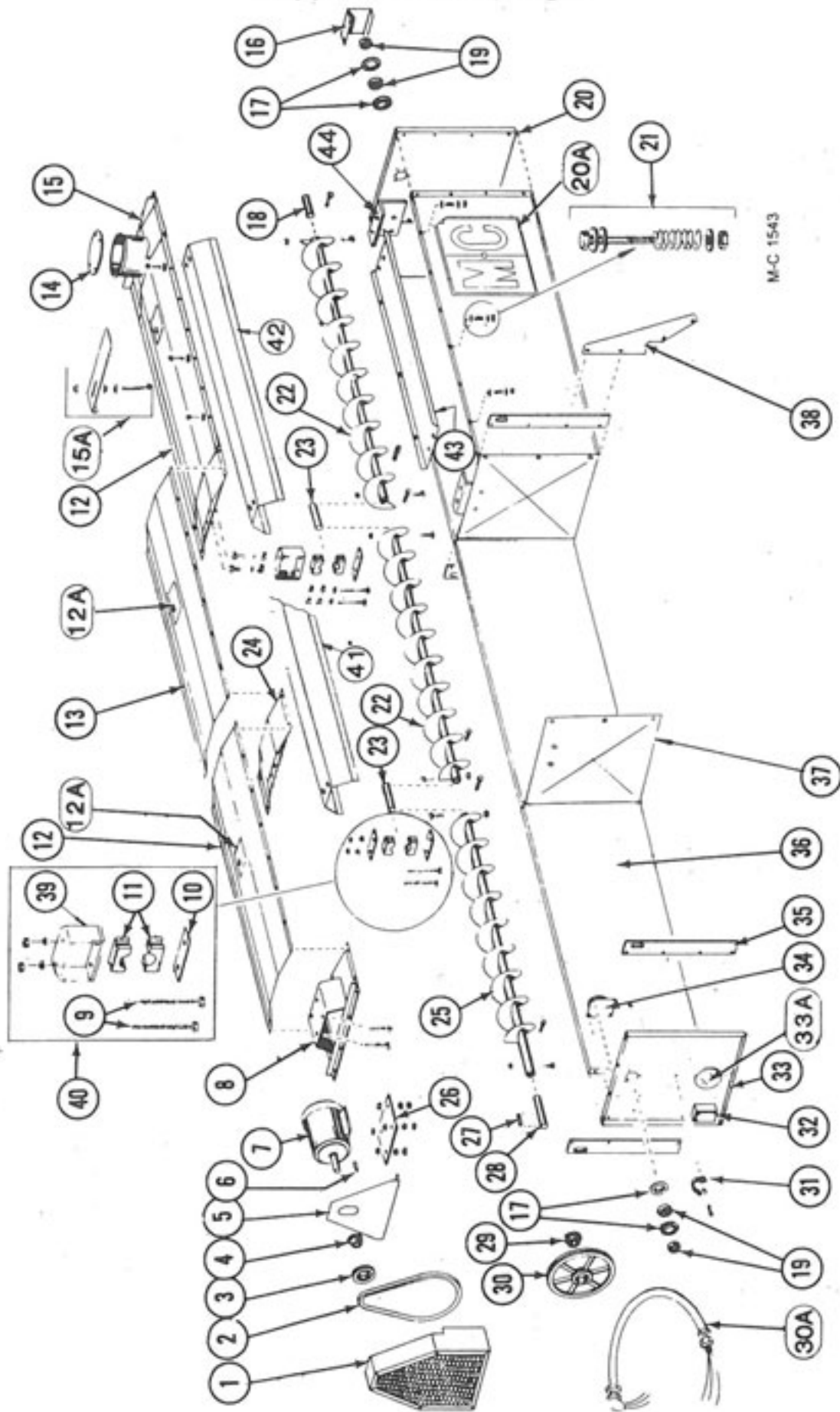

Hopper and Level Auger

Ref.	Part No.	Qty. (16')	Qty. (24')	Description
22	128 0122	1	2	Level Auger (93½" RH flighting)
23	128 5050	1	2	Level Auger Center Shaft (1¼" x 10¼")
24	129 0000	1	2	Level Auger Support
25	128 0317	1	1	Level Auger (82½" RH flighting)
	001 8137	8	12	¾-16 x 2" Capscrew - Grd. 5
	001 8149	8	12	¾-16 Two-Way Locknut
26	129 4202	1	1	Level Auger Motor Mt. Plate
	000 8161	4	4	½-13 x 3½" Capscrew (Full thread)
	000 8170	4	4	½-13 Flanged Locknut
	000 8163	8	8	½-13 Hex Nut
27	001 5120	1	1	Key-¼" x 1½"
28	128 5051	1	1	Level Auger Front Shaft (1¼" x 10")
29	121 6241	1	1	1½" SK Bushing (incl. capscrews & lockwashers)
30	128 6208	1	1	3V/19.0 x 2 Grv.
30A	128 1960	1	1	Flexible Conduit w/Wires
31	128 8951	1	1	Rubber Strap w/Hook
32	128 6922	1	1	Slatter Box (½")
33	129 2835	1	1	Upper End Panel - Front
33A	129 5702	1	1	Port View Lens
34	128 6992	1	1	Bin Level Indicator (See pg. 59)
35	129 3412	4	4	Lifting Bar
36	129 2836	4	6	Hopper Side
37	129 2715	1	2	Hopper Sectional Panel
38	129 2603	6	8	Hopper Brace
39	128 0292	1	2	Level Auger Brg. Support
	001 8135	2	4	¾-16 x 1" Capscrew - Grd. 5
	001 8139	2	4	¾" Lockwasher
	000 8162	2	4	¾-16 Hex Nut
40	122 1008	1	2	Level Auger Brg. Kit (Incl. ref. 10, 11, 39 & 40 in quantities reqd. for one brg.)
41	129 2839	—	1	Auger Cover Long
42	129 2838	1	1	Auger Cover Short
43	128 2761	1	1	Pan Under Auger
44	128 2760	2	2	Auger Pan Support Bracket

Walkway

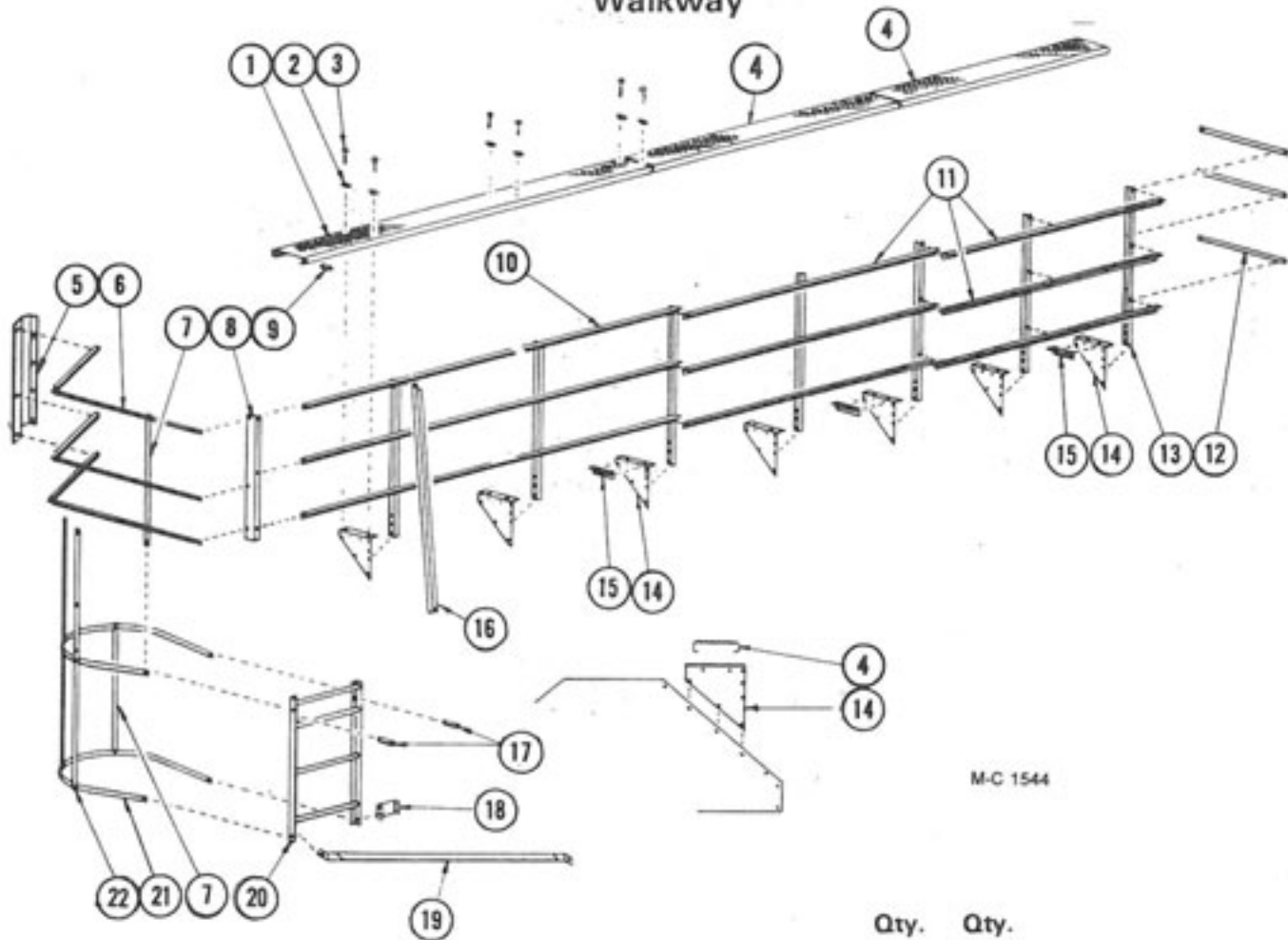

M-C 1544

Ref.	Part No.	Qty. (16')	Qty. (24')	Description
1	129 5701	1	1	Walkway Grating (10')
2	120 8994	12	18	Walkway Grating Anchor Clip
3	001 8276	12	18	5/16-18 x 3" Carriage Bolt
	000 8169	12	18	5/16-18 Flanged Locknut
4	129 8700	1	2	Walkway Grating (8') - See note
5	124 2600	1	1	Walkway Rail Brkt.
6	129 2003	3	3	Strengthening Rails (67¼")
7	129 2011	2	2	Ladder Cage Straps (35½")
8	129 2601	1	1	End Rail Support (39½")
9	129 5406	1	1	Walkway Stand-Off ¾" x 1¼"
10	129 2006	3	3	Guard Rail (122")
11	129 2004	3	6	Standard Guard Rail (97½")
12	129 2008	3	3	Short Guard Rail (23")
13	129 2015	5	7	Guard Rail Brace (49½")
14	129 2600	5	7	Bridge Support
15	129 2602	2	3	Walkway Grating Support
16	129 2007	1	1	Walkway Leg (60½")
17	129 5405	2	2	Ladder Mount Stand-Off ¾" x 3¼"
	000 8257	2	2	¾-16 x 5" Capscrew-Full Thread
	000 8168	2	2	¾-16 Flanged Locknut
18	128 2660	1	1	Ladder Mounting Brkt.
19	128 2661	1	1	Ladder Mounting Angle (33½")
20	129 0004	1	1	Ladder (3')
21	128 2015	2	2	Ladder Cage Hoop
22	129 2014	2	2	Walkway Cage Strap (67¼")

Service Platform Ladder(s)

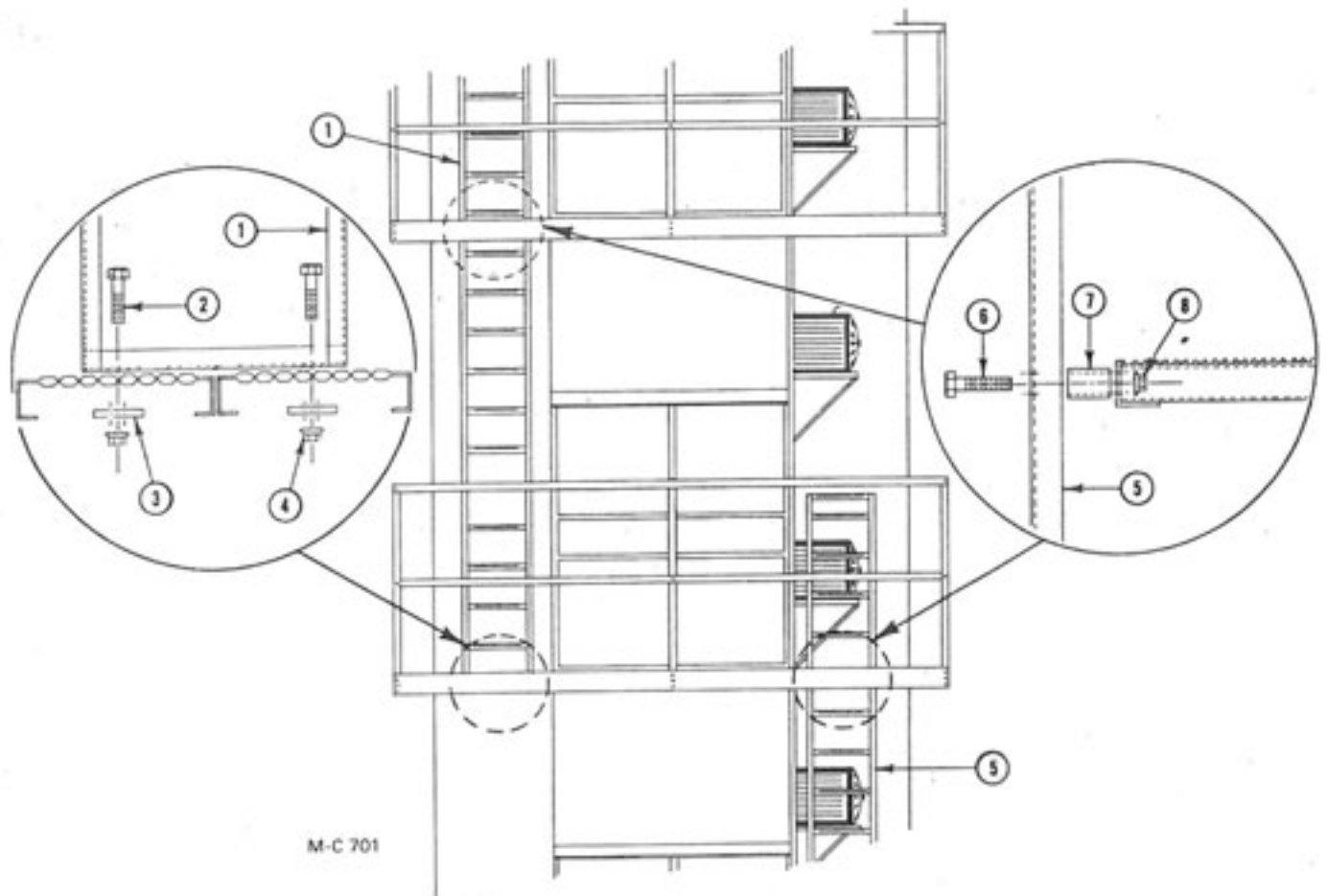

Ref.	Part No.	Qty.	Description
1	120 0045	1	Upper Platform Ladder - 11½' (Not on 875 or 1175)
2	000 8123	2	⅜-16 x 1¼" Capscrew
3	128 4525	2	Flatwasher ⅜ x 2" OD
4	000 8168	2	⅜-16 Flanged Locknut
5	120 0044	1	Lower Platform Ladder - 14½'
6	000 8226	2	⅜-16 x 2" Capscrew
7	091 5427	2	Spacer - 1" Long
8	000 8168	2	⅜-16 Flanged Locknut

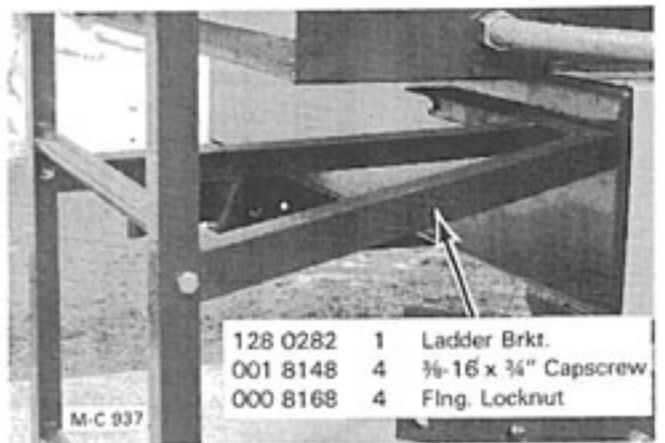

128 0282	1	Ladder Brkt.
001 8148	4	⅜-16 x ¾" Capscrew
000 8168	4	Flng. Locknut

Rear Ladders

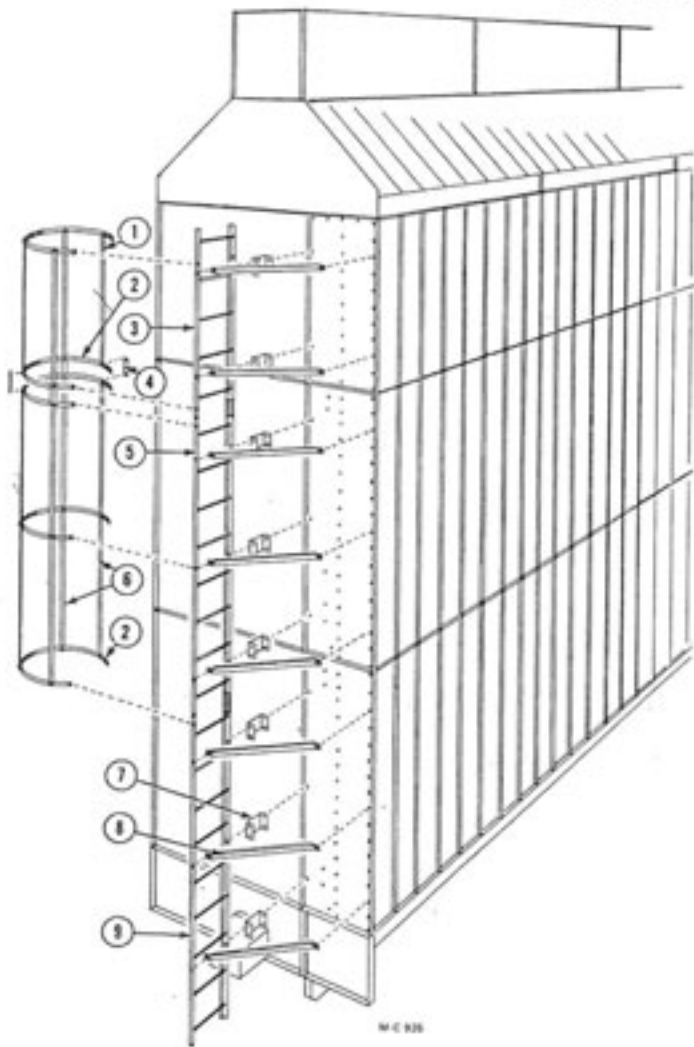

Ref.	Part No.	Description
1	129 2010	Ladder Cage Strap - 5 ft.
2	128 2015	Ladder Cage Hoop
3	129 0005	Ladder - 5 ft.
4	128 2019	Ladder Cage Tie
5	128 0161	Ladder - 8ft.
6	128 2016	Ladder Cage Strap - 8ft.
	128 2017	Ladder Cage Strap - 9ft.
7	128 2660	Ladder Mtg. Brkt.
8	128 2661	Ladder Mounting Angle
9	128 0163	Ladder 9 ft.
—	000 8121	3/8-16 x 1" Capscrew
—	000 8119	3/8-16 x 3/4" Capscrew
—	000 8168	3/8-16 Flanged Locknut

Service Platform

(Quantity is for Single Platform)



Ref.	Part No.	Qty.	Description	Ref.	Part No.	Qty.	Description
1	120 2614	2	"U" Bracket	17	120 8700	2	Long Floor Plank (81")
2	120 2607	1	Side Hand Rail - Left (104-11/16")	18	120 8994	32	Grating Anchor Clip
3	120 2611	5	Center and End Post (45 7/8")	19	120 4314	2	Support Gusset - Right
4	120 4315	2	Support Gusset - Left	20	120 2617	2	End Flange - Right
5	120 2610	2	Side Kick Rail	21	120 2608	1	Front Kick Rail (96")
6	120 2618	2	End Flange - Left	22	120 2615	1	Side Hand Rail - Right (104-11/16")
7	120 2601	2	Side, Toe Guard (81 1/4")	23	120 2612	1	Front Hand Rail (100")
8	120 2609	2	Corner Brace (44")		000 8104	77	5/16-18x3/4" Truss Hd. Screw
9	120 2605	2	Small Corner Clip		001 8276	32	5/16-18 x 3" Carriage Bolt
10	120 2602	2	Inside Support Angle (84 7/8")		000 8109	14	5/16-18 x 1 1/4" Capscrew
11	120 2603	1	Opening Flange (23 3/4")		000 8169	123	5/16-18 Flanged Locknut
12	120 2613	1	Center Angle (52 1/2")		000 8134	10	3/8-16 x 3/4" Truss Hd. Screw
13	120 2606	1	Front Toe Guard (96")		000 8289	6	3/8-16 x 1 1/2" Capscrew
14	120 4313	1	Support Angle (96")		000 8168	22	3/8-16 Flanged Locknut
15	120 8702	2	Medium Floor Plank (54")		133 8161	4	1/2-13 x 1 1/2" Capscrew
16	120 8704	4	Short Floor Plank (48")		000 8170	4	1/2-13 Flanged Locknut

Service Platform

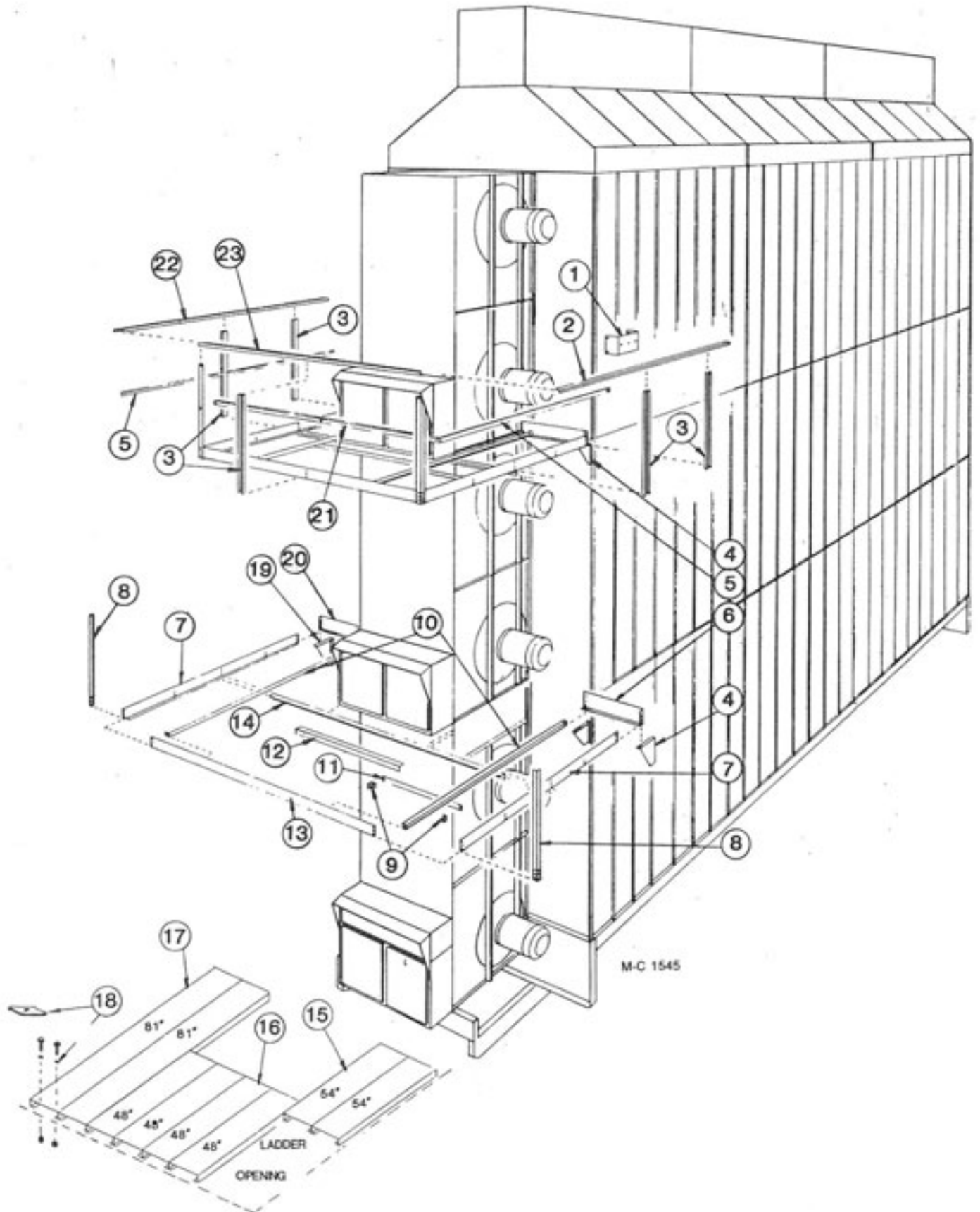

DRYER MOTORS, CIRCUIT BREAKERS AND MAGNETIC STARTERS

MOTOR			CIRCUIT BREAKER			MAGNETIC STARTER			
HP	*FLA	Part No.	Part No.	Amps	Sq."D" No.	Starter Part No.	Sq."D" No.	Thermal Unit Part No.	Thermal Unit Size

200/208V - 3 PHASE - 60 HZ

□ 1.5	5.98	127 6833	128 6882	15	QOU 315	124 6931	DPS033	128 6947	B 9.10
‡ 1.5	5.98	127 6861	128 6882	15	QOU 315	124 6931	DPS033	128 6947	B 9.10
2	7.82	127 6841	128 6882	15	QOU 315	124 6931	DPS033	128 6863	B 11.5
3	11.0	127 6832	124 6875	20	QOU 320	124 6931	DPS033	128 6823	B 17.5
5	17.5	127 6843	124 6876	35	QOU 335	124 6931	DPS033	120 6857	B 32
7.5	25.3	127 6858	124 6904	50	QOU 350	124 6930	DPS053	128 6979	B 40
10	32.2	203 6809	125 6912	60	QOU 360	124 6930	DPS053	128 6950	B 50
15	48.3	126 6854	128 6885	90	QOU 390	124 6930	DPS053	128 6953	B 79
20	62.1	127 6853	128 6966	100	QOU 3100	124 1082	DPA73	128 6827	CC 87.7
25	67.0	127 6852	128 6887	110	Q2L 3110	124 1082	DPA73	120 6844	CC 103
30	80.0	127 6859	124 6906	125	Q2L 3125	124 1083	DPA93	128 6954	CC 132

230V - 1 PHASE - 60 HZ

□ 1.5	8.3	121 6846	128 6878	20	QOU 220	124 6931	DPS033	128 6863	B 11.5
‡ 1.5	10.6	127 6863	128 6878	20	QOU 220	124 6931	DPS033	120 6850	B 15.5
2	12.3	121 6862	124 6903	25	QOU 225	124 6931	DPS033	128 6949	B 19.5
3	20.0	128 6829	124 6909	40	QOU 240	124 6931	DPS033	120 6857	B 32
5	28.0	201 6815	128 6880	60	QOU 260	124 6930	DPS053	128 6979	B 40
† 7.5	38.5	124 6816	124 6908	80	QOU 280	124 6930	DPS053	124 6910	B 66
† 7.5	38.5	124 6888	124 6908	80	QOU 280	124 6930	DPS053	124 6910	B 66
10	45.0	124 6818	128 6881	90	QOU 290	124 6930	DPS053	128 6953	B 79
20	92.0	124 6879	124 6881	125	Q2L 2125	124 1083	DPA93	128 6820	CC 156

230V - 3 PHASE - 60 HZ

□ 1.5	5.0	121 6845	128 6882	15	QOU 315	124 6931	DPS033	120 6851	B 7.70
‡ 1.5	5.0	127 6860	128 6882	15	QOU 315	124 6931	DPS033	120 6851	B 7.70
2	6.0	121 6861	128 6882	15	QOU 315	124 6931	DPS033	128 6947	B 9.10
3	9.0	128 6818	128 6882	15	QOU 315	124 6931	DPS033	125 6931	B 14.0
5	13.8	128 6815	124 6907	25	QOU 325	124 6931	DPS033	120 6855	B 25
7.5	20.6	121 6948	128 6968	40	QOU 340	124 6931	DPS033	128 6946	B 36
10	27.2	201 6818	125 6912	60	QOU 360	124 6930	DPS053	120 6853	B 45
15	39.2	201 6819	128 6891	80	QOU 380	124 6930	DPS053	128 6978	B 70
20	49.6	125 6934	128 6885	90	QOU 390	124 1082	DPA73	128 6972	CC 74.6
25	61.0	201 6842	128 6966	100	QOU 3100	124 1082	DPA73	128 6827	CC 87.7
30	73.0	128 6986	128 6887	110	QL2 3110	124 1083	DPA93	128 6820	CC 156

*IF FLA (Full Load Amps) shown does not match FLA imprinted on motor name plate, refer to Square D charts for correct thermal unit size.

□ - 5/8" shaft

‡ - 7/8" shaft

† - 124 6816 has 1 3/8" shaft. 124 6888 has 1 1/8" shaft.

DRYER MOTORS, CIRCUIT BREAKERS AND MAGNETIC STARTERS

MOTOR			CIRCUIT BREAKER			MAGNETIC STARTER			
HP	*FLA	Part No.	Part No.	Amps	Sq."D" No.	Starter Part No.	Sq."D" No.	Thermal Unit Part No.	Thermal Unit Size
380V - 3 PHASE - 50 HZ									
1.5	2.9	127 6860	128 6931	15	FAL 36015	124 6931	DPS033	128 6951	B 6.25
**1.5	2.9	123 6876	128 6931	15	FAL 36015	124 6931	DPS033	128 6951	B 6.25
2	3.7	121 6861	128 6931	15	FAL 36015	124 6931	DPS033	120 6845	B 6.90
**2	3.7	124 6867	128 6931	15	FAL 36015	124 6931	DPS033	120 6845	B 6.90
3	5.2	128 6818	128 6931	15	FAL 36015	124 6931	DPS033	128 6947	B 9.10
15	23.0	201 6819	128 6937	60	FAL 36060	124 6930	DPS053	120 6853	B 45
20	30.5	125 6842	124 6905	70	FAL 36070	124 6930	DPS053	128 6950	B 50
25	35.9	128 6986	125 6929	80	FAL 36080	124 6930	DPS053	128 6983	B 56

460V - 3 PHASE - 60 HZ

□ 1.5	2.5	121 6845	128 6931	15	FAL 36015	124 6931	DPS033	128 6984	B 3.00
‡ 1.5	2.5	127 6860	128 6931	15	FAL 36015	124 6931	DPS033	128 6984	B 3.00
2	3.0	121 6861	128 6931	15	FAL 36015	124 6931	DPS033	128 6948	B 4.15
3	4.5	128 6818	128 6931	15	FAL 36015	124 6931	DPS033	120 6845	B 6.9
5	6.9	128 6815	128 6931	15	FAL 36015	124 6931	DPS033	128 6952	B 10.2
7.5	10.3	121 6948	128 6933	20	FAL 36020	124 6931	DPS033	128 6823	B 17.5
10	13.6	201 6818	125 6928	30	FAL 36030	124 6931	DPS033	120 6855	B 25.0
15	19.6	201 6819	128 6930	40	FAL 36040	124 6930	DPS053	128 6946	B 36
20	24.8	125 6934	128 6937	60	FAL 36060	124 6930	DPS053	120 6853	B 45
25	31	201 6842	124 6905	70	FAL 36070	124 6930	DPS053	128 6983	B 56
30	37	128 6986	125 6929	80	FAL 36080	124 6930	DPS053	128 6978	B 70

575V - 3 PHASE - 60 HZ

□ 1.5	2	127 6815	128 6931	15	FAL 36015	124 6931	DPS033	128 6984	B 3.00
‡ 1.5	2	127 6862	128 6931	15	FAL 36015	124 6931	DPS033	128 6984	B 3.00
2	2.4	127 6816	128 6931	15	FAL 36015	124 6931	DPS033	120 6848	B 3.70
3	3.6	127 6814	128 6931	15	FAL 36015	124 6931	DPS033	120 6829	B 5.50
5	5.5	127 6847	128 6931	15	FAL 36015	124 6931	DPS033	128 6985	B 8.20
7.5	8.2	127 6828	128 6931	15	FAL 36015	124 6931	DPS033	128 6863	B 11.5
10	10.8	127 6857	128 6933	20	FAL 36020	124 6931	DPS033	128 6823	B 17.5
15	15.6	127 6845	125 6928	30	FAL 36030	124 6931	DPS033	128 6971	B 28
20	19.8	127 6844	128 6930	40	FAL 36040	124 6931	DPS033	128 6946	B 36
25	25	127 6846	128 6937	60	FAL 36060	124 6930	DPS053	120 6853	B 45
30	30	124 6902	128 6937	60	FAL 36060	124 6930	DPS053	128 6983	B 56

*If FLA (Full Load Amps) shown does not match FLA imprinted on motor name plate, refer to Square D charts for correct thermal unit size.

**"C" Face

□ - 5/8" shaft

‡ - 7/8" shaft

115V COILS AND INTERLOCKS

STARTER		COIL		INTERLOCK	
Sq. "D" No.	M-C No.	M-C No.	Sq. "D" No.	M-C No.	Sq. "D" No.
DPA73	124 1082	122 6861	9998-DA3V02	124 6933	9999-D-20
DPA93	124 1083	122 6861	9998-DA3V02	124 6933	9999-D-20
DPS053 (50) HZ	124 6930	122 6860	9998-DA1V02	124 6933	9999-D-20
DPS033 (50) HZ	124 6931	122 6860	9998-DA1V02	124 6933	9999-D-20
DPS033 (60) HZ	124 6931	122 6860	9998-DA1V02	124 6933	9999-D-20
DPS053 (60) HZ	124 6930	122 6860	9998-DA1V02	124 6933	9999-D-20

JUMPER STRAP KITS AND CONTACT KITS

STARTER		JUMPER STRAP KIT (2 straps per kit)		CONTACT KIT	
Sq. "D" No.	M-C No.	M-C No.	Sq. "D" No.	M-C No.	Sq. "D" No.
DPA73	124 1082	124 6885	9998-S032	122 6863	9998-DRC7
DPA93	124 1083	124 6885	9998-S032	122 6864	9998-DRC9
DPS033 (50) HZ	124 6931	120 6841	9998-S031		
DPS053 (50) HZ	124 6930	120 6841	9998-S031	122 6862	9998-DRC5
DPS033 (60) HZ	124 6931	120 6841	9998-S031		
DPS053 (60) HZ	124 6930	120 6841	9998-S031	122 6862	9998-DRC5

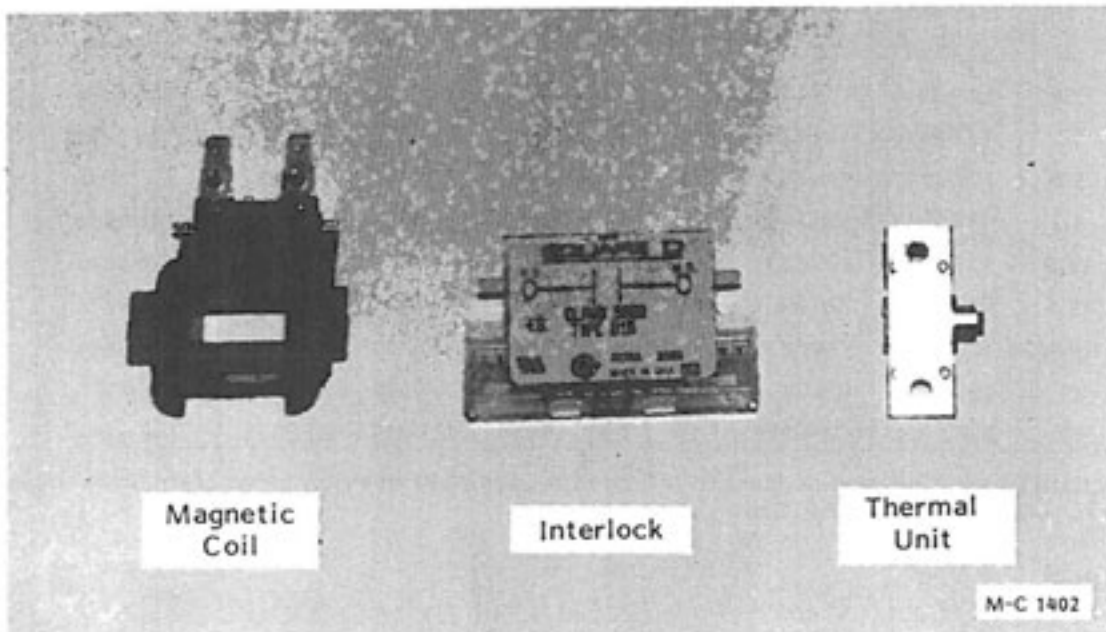

10" Unloading Auger Extension Kit (2') - 127 1229

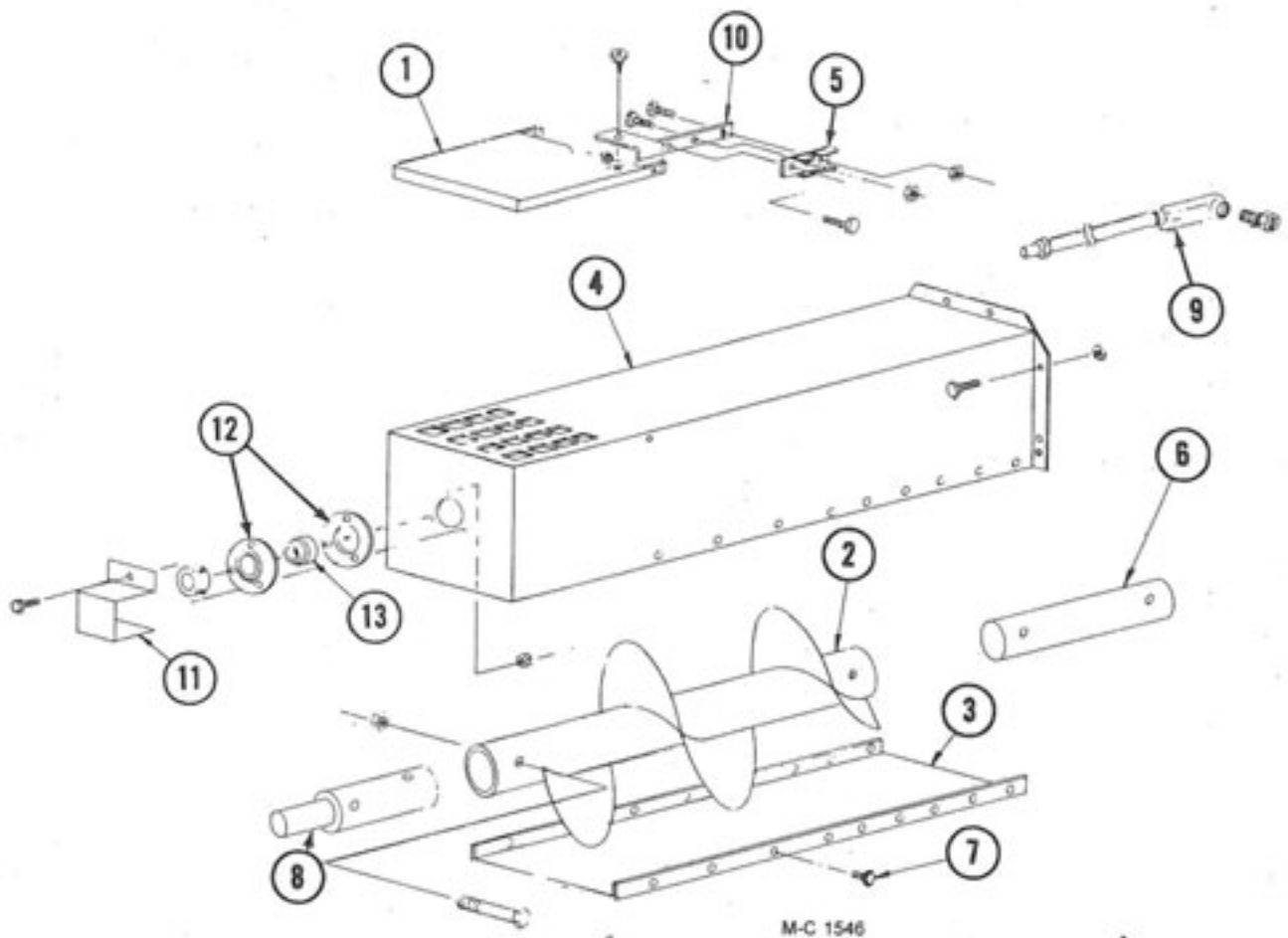

Ref.	Part No.	Qty.	Description
1	128 4712	1	Over Load Door
2	128 0310	1	2' Extension Auger
3	124 4465	1	2' Bottom Cover
4	128 0311	1	2' Discharge Housing
5	120 6801	1	Bulb Mount
6	128 5618	1	Unload Auger Link
7	001 8284	8	5/16-12 x 1/2" Tapping Bolt
8	124 5611	1	U.A. Output Shaft
9	127 1231	1	2' Extension Liquatite Assembly
10	128 2937	1	U.A. Bulb Bracket
11	128 3011	1	Stub Shaft Guard
12	001 6004	2	1 1/4" Bearing Flangettes
13	001 6003	1	1 1/4" Bearing w/Collar

Portabilities

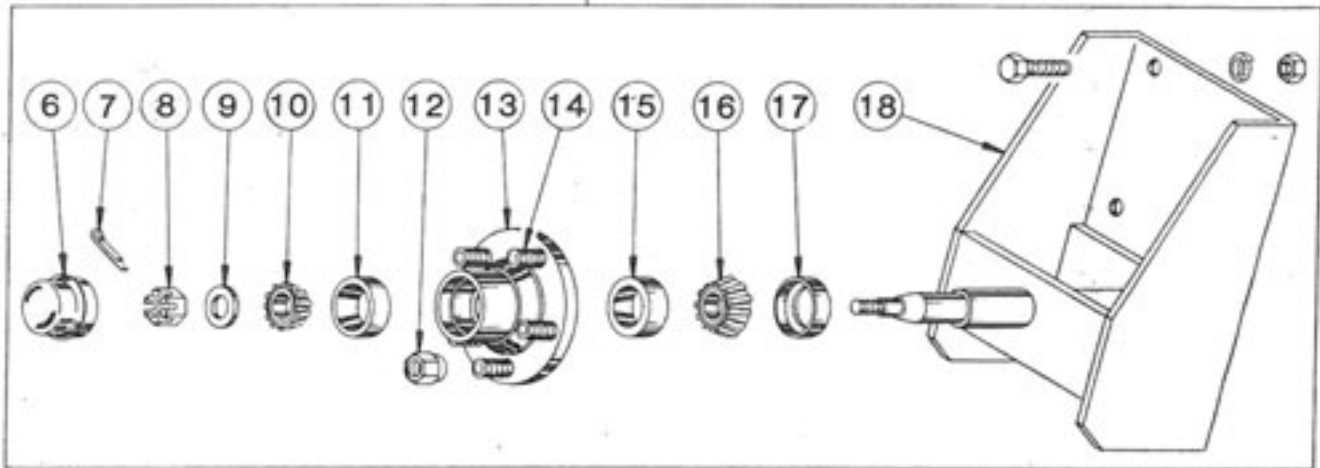
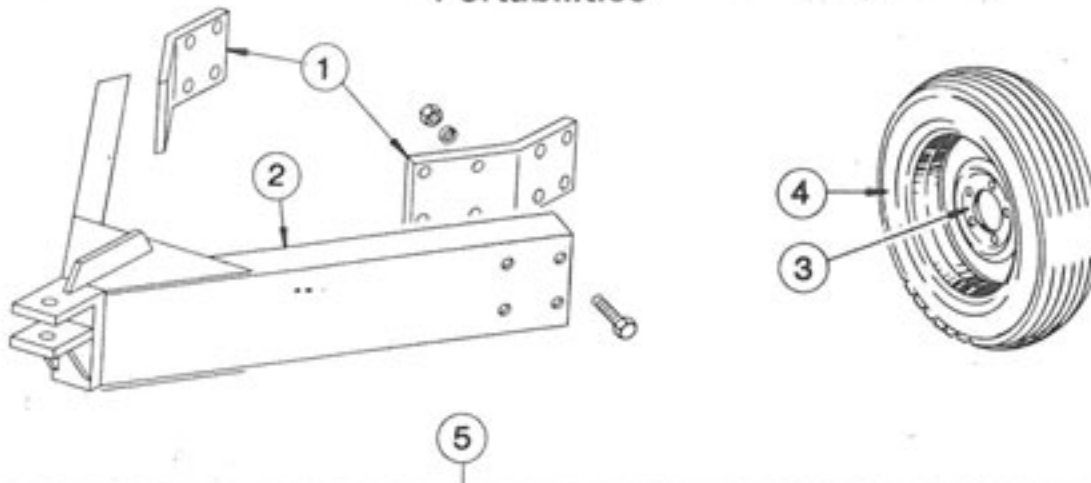

M-C 980

120 1030 - 4 Wheel Portabilities (Incl. ref. 1 & 2 and four of ref. 3 & 5 - less tires)

120 1031 - 6 Wheel Portabilities (Incl. ref. 1 & 2 and six of ref. 3 & 5 - less tires)

120 1043 - 8 Wheel Portabilities (Incl. ref. 1 & 2 and eight of ref. 3 & 5 - less tires)

120 1040 - Additional Portabilities (Incl. two of ref. 3 & 5 - less tires)

Ref.	Part No.	Qty.	Description	Ref.	Part No.	Qty.	Description
1	128 3671	2	Pole Mount Brkt.	6	001 8996	1	Hub Cap
	128 8196	8	3/4 - 10 x 2 1/2" Capscrew - Grd. 5	7	001 8252	1	Cotter Pin - 1/8" x 1"
	000 8182	8	3/4" Lockwasher	8	001 8253	1	Spindle Nut
	000 8165	8	3/4 - 10 Hex Nut	9	001 8254	1	Spindle Washer
2	120 0047	1	Dryer Pole	10	001 6000	1	Bearing Cone - Outer
	128 8195	8	3/4 - 10 x 2" Capscrew - Grd. 5	11	002 6000	1	Bearing Cup - Outer
	000 8182	8	3/4" Lockwasher	12	001 8989	5	1/2 - 20 Lug Nut - 45°
	000 8165	8	3/4 - 10 Hex Nut	13	001 8992	1	Wheel Hub Ass'y. - 5 Bolt (incl. ref. 11, 14 & 15)
3	001 8993	1	5 Bolt Wheel - 15"	14	002 8152	5	1/2 - 20 x 1 1/2" Stud
4	127 8990	1	7.60 x 15 - 6 Ply Tubeless Tire	15	002 6001	1	Bearing Cup - Inner
5	120 1028	1	Wheel Spindle & Hub Ass'y. (inc ref. 6 thru 18)	16	001 6001	1	Bearing Cone - Inner
	000 8146	6	5/8 - 11 x 1 1/2" Capscrew - Grd. 5	17	001 8991	1	Seal
	000 8181	6	5/8" Lockwasher	18	120 0031	1	Wheel Mount
	000 8164	6	5/8 - 11 Hex Nut				



Iron Horse Quality