

\$5.00

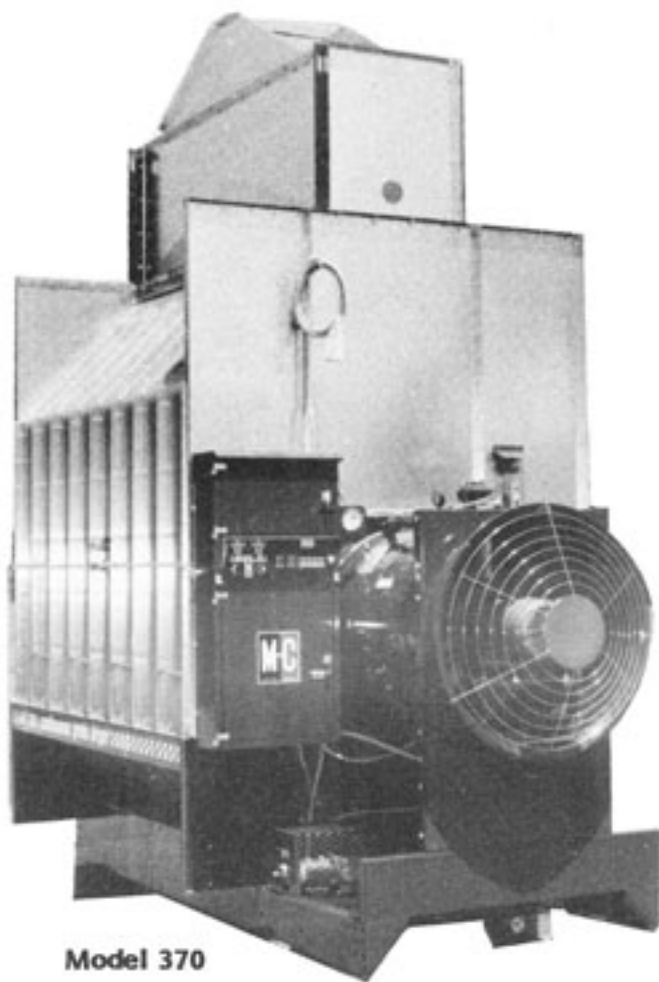

Model 370 & 570 Continuous Flow Grain Dryers

(Starting w/Serial No. 52698)



Model 370

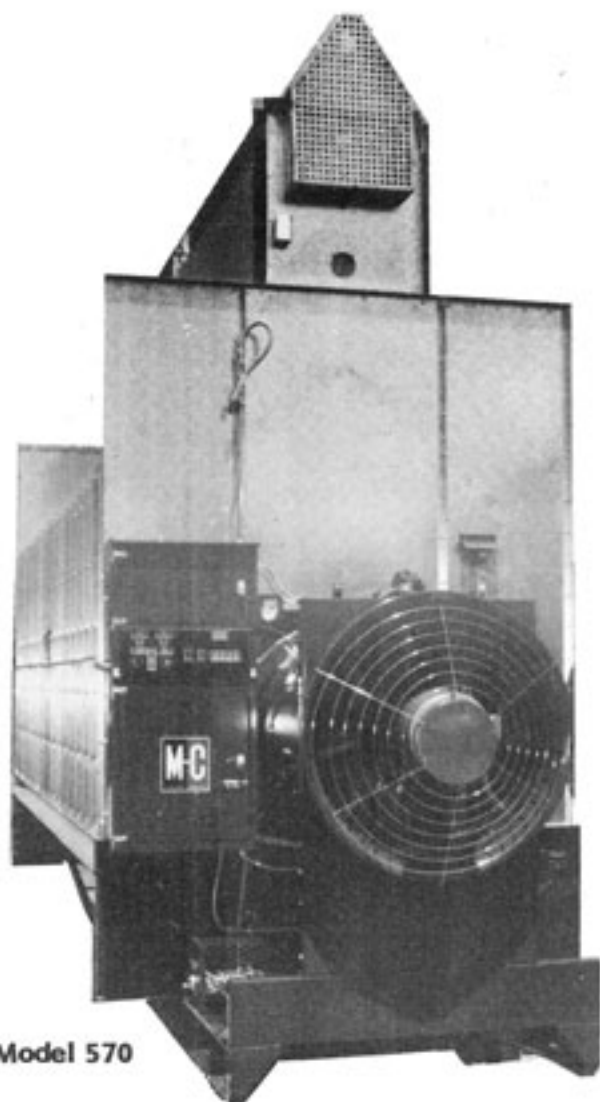

Model 570

PARTS MANUAL

Form No. D 309 October 1993

Mathews Company / 500 Industrial Ave., Crystal Lake, IL 60012, U.S.A.
815/459-2210 FAX 815/459-5889

CONTENTS

	Page
Introduction	
Parts Ordering Instructions	1
Model and Serial Number Location	1
Capscrew Grade Identification	1
 Parts	
Air Pressure Switch	31
Augers	
Level	28
Unload	2-7
Belts	
Level Auger	28
Unload Auger	14
Bin Level Indicator	31
Burner	17
Cabinets	
115V Control Cabinet	24-26
Circuit Breakers - Level Auger, Unload Auger & Fan Motor	32-33
Coils	
Magnetic Starter - 115V	32-33
$\frac{3}{4}$ " Solenoid Valve	21
$1\frac{1}{4}$ " Solenoid Valve	23
$\frac{1}{2}$ " Solenoid Valve	22
Contacts - For Magnetic Starters	34
Control Panel Lights, Switches and Controls	27
Decal Kit - All Models	13
Electrical Components in 115V Control Cabinet	26
Electrode	19
End Panels	
370 and 570	12
Fan	18
Fan Motor	18
Fan Motor Mount	18
Fan Orifice	16
Fan Orifice Supports	16
Flame Sensing Probe	19
Floor Panels - 370 and 570	12
Guards	
Fan	16
Level Auger Motor	30
SCR Drive	15

Continued on next page

	Page
High Limit Switch	31
Hopper	
370	30
570	28
Ignition Board	26
Ignition Wires	19
Interlocks - For Magnetic Starters	34
Jumper Straps - For Magnetic Starters	34
Level Auger	
Belts	28
Motor	28
Motor Mount	28
Switch Assembly	31
Lights, Control Panel	27
LP Gas Liquid Line Piping	22
LP Gas Manifold and Piping	20-21
Magnetic Starters	32-33
Manifolds	
LP Gas	20-22
Natural Gas	23
Mercury Switch	2, 4, 6
Metering Rolls	2-7
370	2-3
570	4-7
Modulating Valves	21, 23
Modulating Valve Power Elements	21, 23
Moisture Control	
Moisture Control	27, 31
Moisture-Matic II	26
Potentiometer	27
Thermistor Sensor	31
Motors	32-33
Natural Gas Manifold and Piping	23
Orifice Liner	16
Portabilities	35
Pressure Gauge (Gas)	21, 23
Pressure Regulator (LP Gas)	21

Continued on next page

	Page
Relays	26
Relief Valve - LP Gas	22
SCR Drive Unload System	
Control Board	26
Motor and Gear Box	14
Potentiometer	27
Screens	
Base Screens	9
Upper Screens	10
Solenoid Valves	
1 ¼" - Natural Gas	23
½" - LP Gas	22
¾" - LP Gas	20-21
Switches, Control Panel	27
Terminal Tracks	26
Thermistor	31
Thermometer	25
Timers	
10 Second - Ignition	26
.1 to 8 Minute Adjustable - Level Auger	26
60 Minute Adjustable - Low Grain Level	26
Transformers	24
Unload Auger	
Auger	2-7
Belts	14
Motor	14
Pans	8
Vaporizer Coil - LP Gas	17

NOTES

INTRODUCTION

Parts Ordering Instructions

1. Order parts from your local M-C Dealer or distributor.
2. Always furnish the Grain Dryer model and serial number. This information is stamped on the serial number plate.
3. When ordering parts be sure to furnish the part number, description and quantity required.

NOTE: Attaching hardware is listed (but not included) with the main part. It must be ordered separately.

4. Inspect all shipments upon receipt. If any packages and/or boxes are missing, or parts are damaged, file a claim with the carrier immediately. Failure to do so may void a claim. Check the shipment against the packing list carefully. Report any shortages to the shipper immediately.
5. Do not return any parts to the Mathews Company without a "Return Goods Authorization" from the factory. All return parts shipments must be shipped prepaid (COD shipments will not be accepted). Shipments must also include the following:
 - A. A letter of explanation including the "Return Goods Authorization Number," your name and address.
 - B. A list of all parts being returned. List must include part numbers, description, quantity, and original invoice number.

Model and Serial Number Location

The model and serial number of your Grain Dryer are stamped on a plate located on the left front base panel, see Figure 1. On earlier production dryers, the plate is on the dryer front end panel

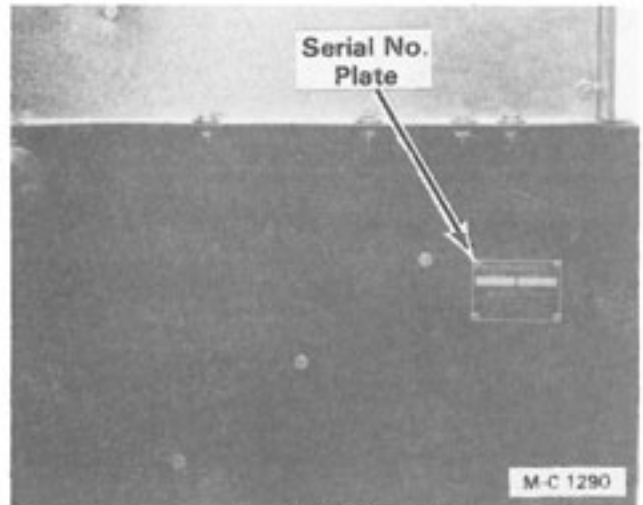

Figure 1

M-C FARM EQUIPMENT	
MODEL NO.	SERIAL NO.

Figure 2

just above the location shown in Figure 1. Record the model and serial number in the blank spaces in Figure 2.

Capscrew Grade Identification

There are four grades of hex-head capscrews. Grade 1 and 2 are common capscrews, grade 5 and 8 are used when greater strength is required. Each grade can be identified by the marking on the head of the capscrew, see chart below.

When replacing capscrews, be sure to use the correct size and grade. If a specific grade is not shown as part of the description, the capscrew is a grade 1 or 2.

CAPSCREW GRADE IDENTIFICATION CHART

S.A.E. Grade	Description	Capscrew Head Marking*
1	WILL HAVE A PLAIN HEAD - NO RADIAL LINES	
2	Low or Medium Carbon Steel Not Heat Treated	
5	WILL HAVE 3 RADIAL LINES Quenched and Tempered Medium Carbon Steel	
8	WILL HAVE 6 RADIAL LINES Quenched and Tempered Special Carbon or Alloy Steel	

*The center marking identifies the capscrew manufacturer.

370 METERING ROLLS AND UNLOAD AUGER

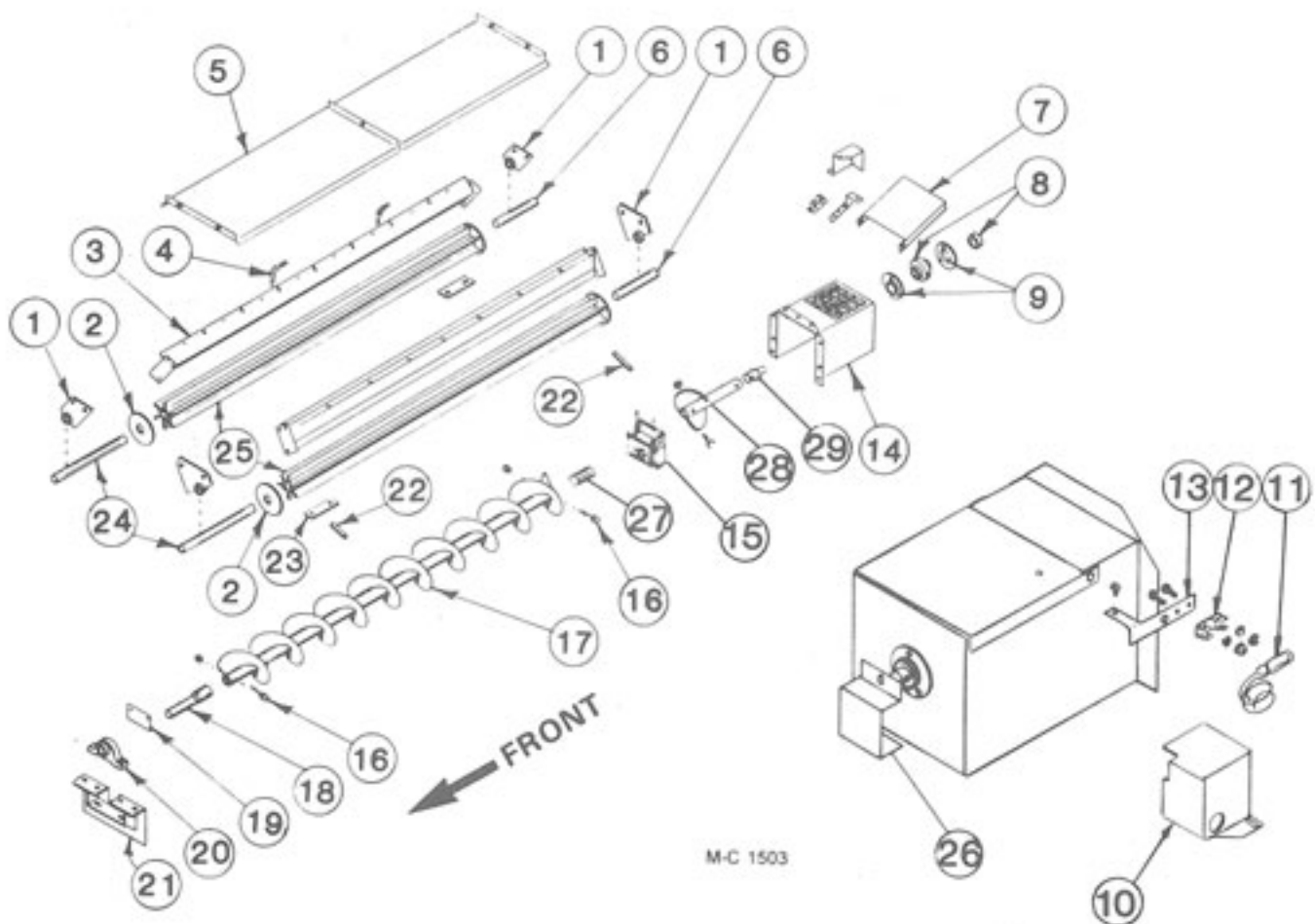

M-C 1503

Ref.	Part No.	Qty.	Description
1	128 1063	4	Metering Roll Brg. w/Bronze Bushing
	000 8106	8	5/16-18 x 3/4" Capscrew
	000 8169	8	5/16-18 Flanged Locknut
2	121 4438	AR	Metering Roll Washer - 11 Gauge
	128 4970	AR	Metering Roll Washer - 16 Gauge
3	128 0225	2	Inner Perf. Mt. Weld
	000 8106	12	5/16-18 x 3/4" Capscrew
	000 8169	12	5/16-18 Flanged Locknut
4	128 8958	4	Support Rod (3/8"x4 3/8")
	000 8173	4	5/16" Flatwasher
	000 8168	12	5/16-18 Flanged Locknut
5	128 2890	2	Unload Auger Cover
	001 8111	4	5/16-18 Clip Nut
	000 8106	5	5/16-18 x 3/4" Capscrew
	000 8173	5	5/16" Flatwasher
	000 8169	1	5/16-18 Flanged Locknut

Ref.	Part No.	Qty.	Description
6	121 5042	2	Metering Roll Stub Shaft (Rear) 1 1/4" x 5" (press fit in metering roll)
7	128 4712	1	Over Load Door
	000 8119	2	5/16-18 x 3/4" Capscrew
	000 8205	2	5/16-18 Top Lock Flanged Nut
8	001 6003	1	1 1/4" Bearing w/Lock Collar
9	001 6004	2	1 1/4" Bearing Flangette
	000 8119	3	5/16-18 x 3/4" Capscrew
	000 8168	3	5/16-18 Flanged Locknut
10	128 4896	1	Shut-Off Switch Cover
	001 8284	2	5/16-12 x 1/2" Self-Tapping Screw
11	120 6800	1	Mercury Switch
12	120 6801	1	Mercury Switch Mt. Clip
	000 8282	2	6-32 x 1/4" Machine Screw
	000 8185	2	6-32 Flanged Locknut

370 METERING ROLLS AND UNLOAD AUGER

Ref.	Part No.	Qty.	Description
13	128 2937	1	Bulb Mount
14	128 0242	1	Unload Auger Discharge
	000 8106	9	5/16-18 x 3/4" Capscrew
	000 8169	9	5/16-18 Flanged Locknut
15	122 1007	1	Unload Hanger Brg. Kit
16	000 8229	8	3/8-16 x 2 3/4" Capscrew - Grd. 5
	000 8205	8	Top-Lock Flange Nut
17	128 0244	1	Unload Auger (10")
18	124 5610	1	Unload Auger Input Shaft
19	128 3008	1	Front Seal Plate
	000 8184	4	8-18 x 1/2" Sheet Metal Screw
20	001 6011	1	1-7/16" Bore Pillow Block Brg.
	001 8299	2	1/2"-13 x 1 3/4" Capscrew - Grd. 8 w/Nylock
	001 8257	2	1 1/2" SAE Flatwasher
	000 8163	2	1/2-13 Hex Nut
21	128 0247	1	Unload Auger Front Plate
	000 8119	4	3/8-16 x 3/4" Capscrew
	000 8168	4	3/8-16 Flanged Locknut
22	000 8259	2	Roll Pin 5/16 x 1 3/4"
23	121 2637	2	Clean-Out Cover
	000 8168	4	3/8-16 Flanged Locknut
24	128 5042	2	Metering Roll Shaft (Front) 1 1/4" x 13 1/4" (press fit in metering roll)
25	128 1186	2	Metering Roll Ass'y (Incl. shafts)
26	128 3011	1	Stub Shaft Guard
27	128 5618	1	Unload Auger Link
28	128 0309	1	Standard Auger Weld
29	124 5611	1	Unload Auger O/P Shaft

570 METERING ROLLS AND UNLOAD AUGER

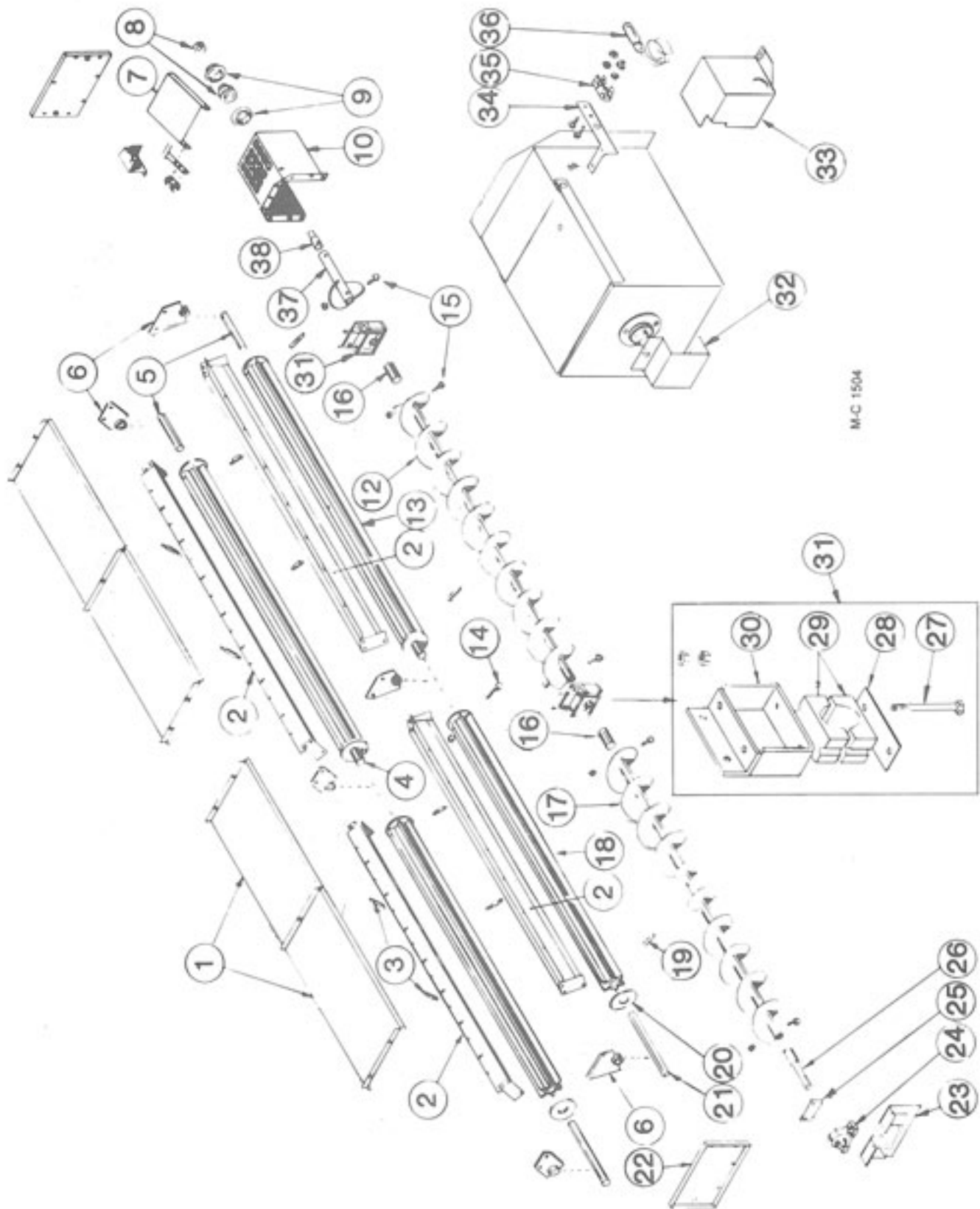

M-C 1504

570 METERING ROLLS AND UNLOAD AUGER

Ref.	Part No.	Qty.	Description	Ref.	Part No.	Qty.	Description
1	128 2890	4	Unload Auger Cover	12	128 0244	1	Rear Unload Auger (10")
	001 8111	8	5/16-18 Clip Nut	13	121 1082	2	Rear Metering Roll Ass'y (Incl. shafts)
	000 8106	12	5/16-18 x 3/4" Capscrew	14	000 8114	2	5/16-18 x 2 1/2" Capscrew
	000 8173	12	5/16" Flatwasher		000 8222	2	5/16" Lockwasher
	000 8169	4	5/16-18 Flanged Locknut		000 8159	2	5/16-18 Hex Nut
2	128 0225	4	Inner Perf. Mt. Weld	15	000 8229	8	3/8-16 x 2 3/4" Capscrew-Grd. 5
	000 8106	18	5/16-18 x 3/4" Capscrew		000 8205	8	Top-Lock Flange Nut
	000 8169	18	5/16-18 Flanged Locknut	16	128 5618	1	Unload Auger Link
3	128 8958	8	Support Rod (3/8" x 4-3/8")	17	128 0244	1	Front Unload Auger (10")
	000 8173	8	5/16" Flatwasher	18	128 1254	2	Front Metering Roll Ass'y (Incl. shaft)
	000 8168	24	3/8-16 Flanged Locknut	19	000 8259	3	Roll Pin 5/16" x 1 3/4"
4	121 5043	2	Center Metering Roll Shaft - 1 1/4" x 7" (press fit in metering roll)	20	121 4438	4	Metering Roll Washer-11 Gauge
5	121 5042	2	Rear Metering Roll Stub Shaft - 1 1/4" x 5" (press fit in metering roll)		128 4970	4	Metering Roll Washer-16 Gauge
6	128 1063	6	Metering Roll Brg. w/Bronze Bushing	21	128 5042	2	Front Metering Roll Shaft - 1 1/4" x 13 1/4" (press fit in metering roll)
	000 8106	12	5/16-18 x 3/4" Capscrew	22	128 2894	2	Base Panel Access Door (17 1/2" x 10 1/2")
	000 8169	12	5/16-18 Flanged Locknut		001 8284	14	5/16-12 x 1/2" Self Tapping Screw
7	128 4712	1	Over Load Door	23	128 0247	1	Unload Auger Front Plate
	000 8119	2	3/8-16 x 3/4" Capscrew		000 8119	4	3/8-16 x 3/4" Capscrew
	000 8205	2	3/8-16 Top Lock Flanged Nut		000 8168	4	3/8-16 Flanged Locknut
8	001 6003	1	1 1/4" Bearing w/Lock Collar	24	001 6011	1	1-7/16" Bore Pillow Block Bearing
9	001 6004	2	1 1/4" Bearing Flangette		001 8299	2	3/8-13 x 1 3/4" Capscrew-Grd. 8 w/Nylock
	000 8121	3	3/8-16 x 1" Capscrew		001 8257	2	1/2" SAE Flatwasher
	000 8168	3	3/8-16 Flanged Locknut		000 8163	2	1/2-13 Hex Nut
10	128 0242	1	Unload Auger Discharge (Front Unload - See Note 1)				
	000 8106	9	5/16-18 x 3/4" Capscrew				
	000 8169	9	5/16-18 Flanged Locknut				
11	128 5998	1	Unload Auger Output Shaft (Front Unload - See Note 1)				

NOTE 1: Dryers w/Front Unload - Ref. 10, use 127 4431 rear cover plate; Ref. 11, use 127 5999 output shaft and Ref. 12, use 128 0243 auger.

Continued on next page

570 METERING ROLLS AND UNLOAD AUGER

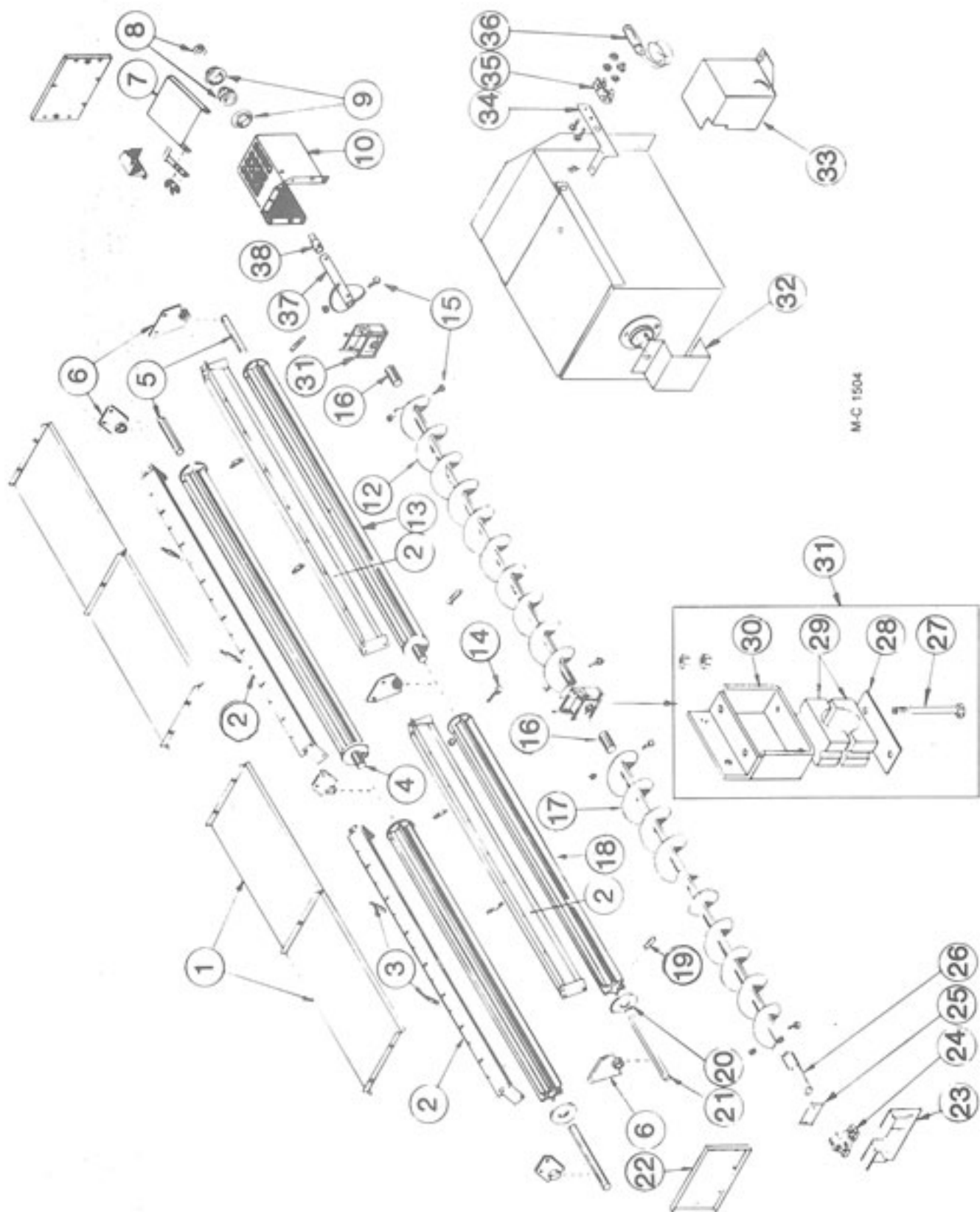

M-C 1504

570 METERING ROLLS AND UNLOAD AUGER

Ref.	Part No.	Qty.	Description
25	128 3008	1	Front Seal Plate
	000 8184	4	8-18 x 1/2" Sheet Metal Screw
26	124 5610	1	Unload Auger Input Shaft
27	001 8168	2	1/2-13 x 4 1/2" Capscrew - Grd. 5
	000 8180	2	1/2" Lockwasher
	000 8163	4	1/2-13 Hex Nut
28	128 4250	1	Unload Auger Mid Brg. Support
29	128 6020	1	Wood Brg. 1-5/16" (2 Halves)
30	128 0287	1	Unload Auger Brg. Brkt.
	000 8137	2	1/2-13 x 1 1/4" Capscrew - Grd. 5
	000 8180	2	1/2" Lockwasher
	000 8163	2	1/2-13 Hex Nut
31	122 1007	2	Unload Auger Brg. Kit (Incl. Ref. 27 thru 30 in quantities reqd. for one brg.)
32	128 3011	1	Stub Shaft Guard
33	128 4896	1	Shut-Off Switch Cover
	001 8284	2	5/16-12 x 1/2" Self-Tapping Screw
34	128 2937	1	Bulb Mount
35	120 6801	1	Mercury Switch Mt. Clip
	000 8282	2	6-32 x 1/4" Machine Screw
	000 8185	2	6-32 Flanged Locknut
36	120 6800	1	Mercury Switch
37	1280309	1	Standard Auger Weld
38	124 5611	1	Unload Auger Output Shaft

UNLOAD AUGER PANS

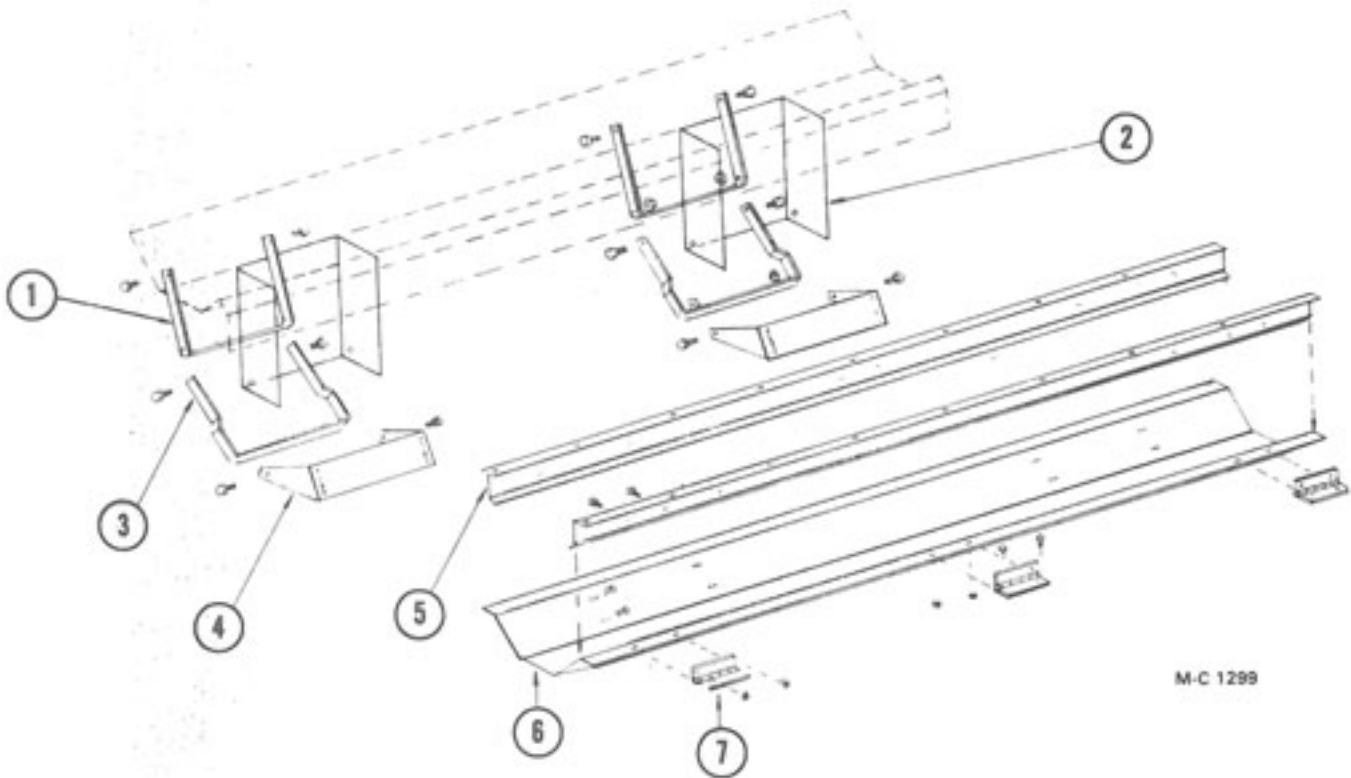

M-C 1289

Ref.	Part No.	370 Qty	570 Qty.	Description
1	128 2029	2	4	Auger Dump Arm - Upper
2	128 8355	2	4	Warning Decal (not shown)
3	128 2030	2	4	Auger Dump Arm - Lower
4	128 2751	2	4	Bottom Link Pivot Base
5	128 2673	2	4	Pan Hinge Angle
6	128 2752	1	2	Auger Dump Pan
7	128 8957	3	6	Hinge

BASE SCREENS

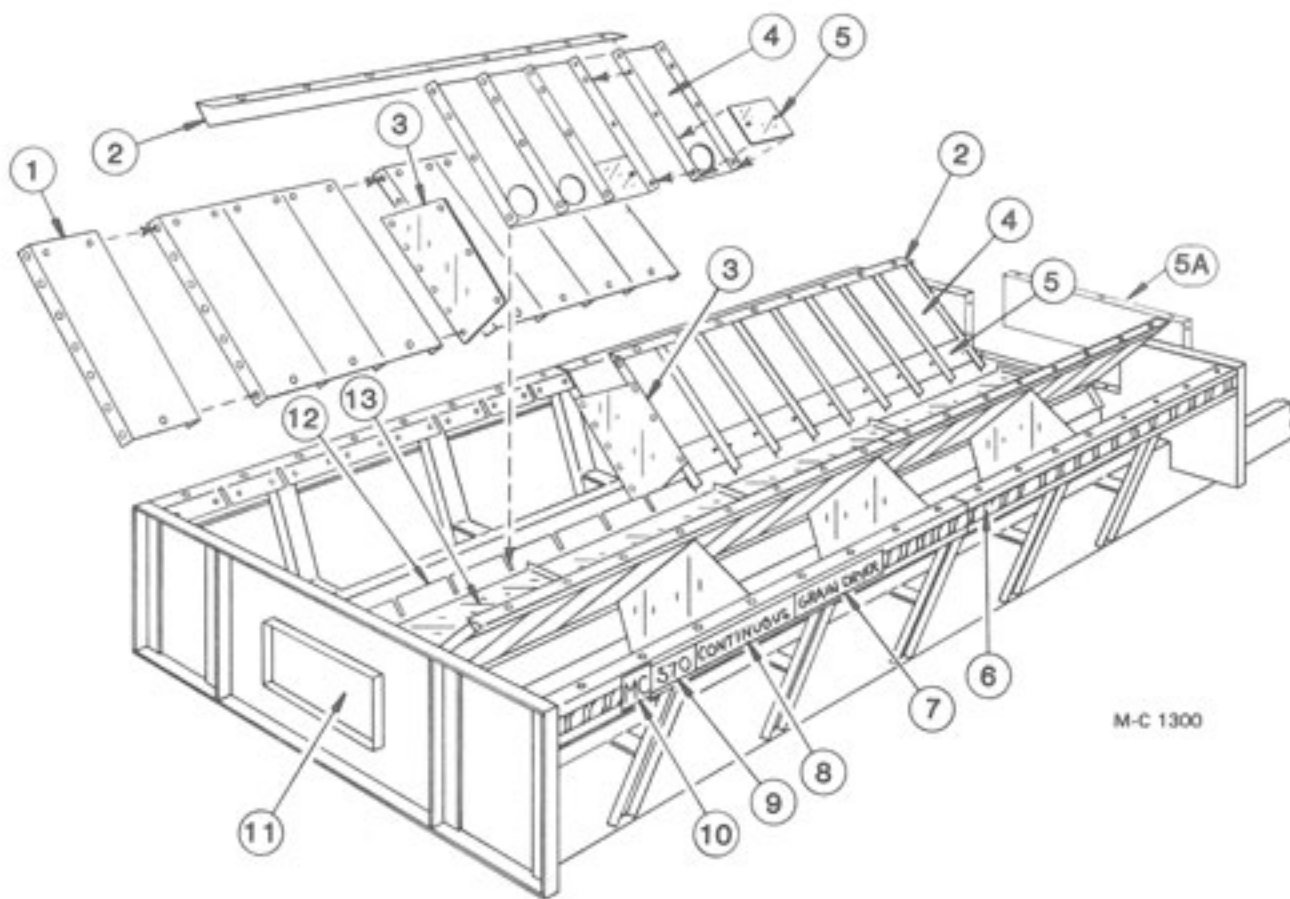

M-C 1300

Ref. Part No.	370 Qty	570 Qty	Description	Ref. Part No.	370 Qty	570 Qty	Description
1	---	---	Lower Outer Screen	7	128 8309	2	"Grain Dryer" Decal
	127 2945	16	32 Small Seed (Galv.)	8	128 8308	2	"Continuous" Decal
2	128 2739	2	4 Lower Screen Mt. Angle	9	128 8374	2	"370" Base Decal
3	128 2855	2	6 Lower Screen Stiffener		128 8376	-	"570" Base Decal
4	---	---	Lower Inner Screen	10	128 8300	2	M-C Decal -
			w/Clean-Out See Note 1)				5" x 4-9/16"
	128 2994	16	32 Galvanized (Std.)	11	128 2894	1	Base Panel Access Door
	127 2960	16	32 Small Seed (Galv.)		001 8284	7	5/16-12 x 1/2" Self-Tapping
5	128 2995	16	32 Lower Inner Screen Cover				Screw
5A	128 4570	1	0 Base Filler Panel	12	128 0225	2	4 Inner Perf. Mt. Weld
			(37" x 13 1/2")		000 8106	12	18 5/16-18 x 3/4" Capscrew
	001 8135	12	12 5/16 x 1" Capscrew -		000 8169	12	18 5/16-18 Flanged Locknut
			Grd. 5	13	128 2890	2	4 Unload Auger Cover
	000 8168	12	12 5/16 Flanged Locknut		001 8111	4	8 5/16-18 Clip Nut
6	128 8310	16'	32' Red & Yellow Stripe		000 8106	5	12 5/16-18 x 3/4" Capscrew
			Decal - 2 1/2"		000 8173	5	12 5/16" Flatwasher
					000 8169	1	4 5/16-18 Flanged Locknut

NOTE 1: Screen without clean-out is no longer available. Order Galvanized (Std.) Screen Assembly, 124 1032 or Small Screen (Galv.) Screen Assembly, 124 1033. Assemblies include Ref. 4 Screen, Ref. 5 Cover and Cover Attaching Hardware.

UPPER SCREENS

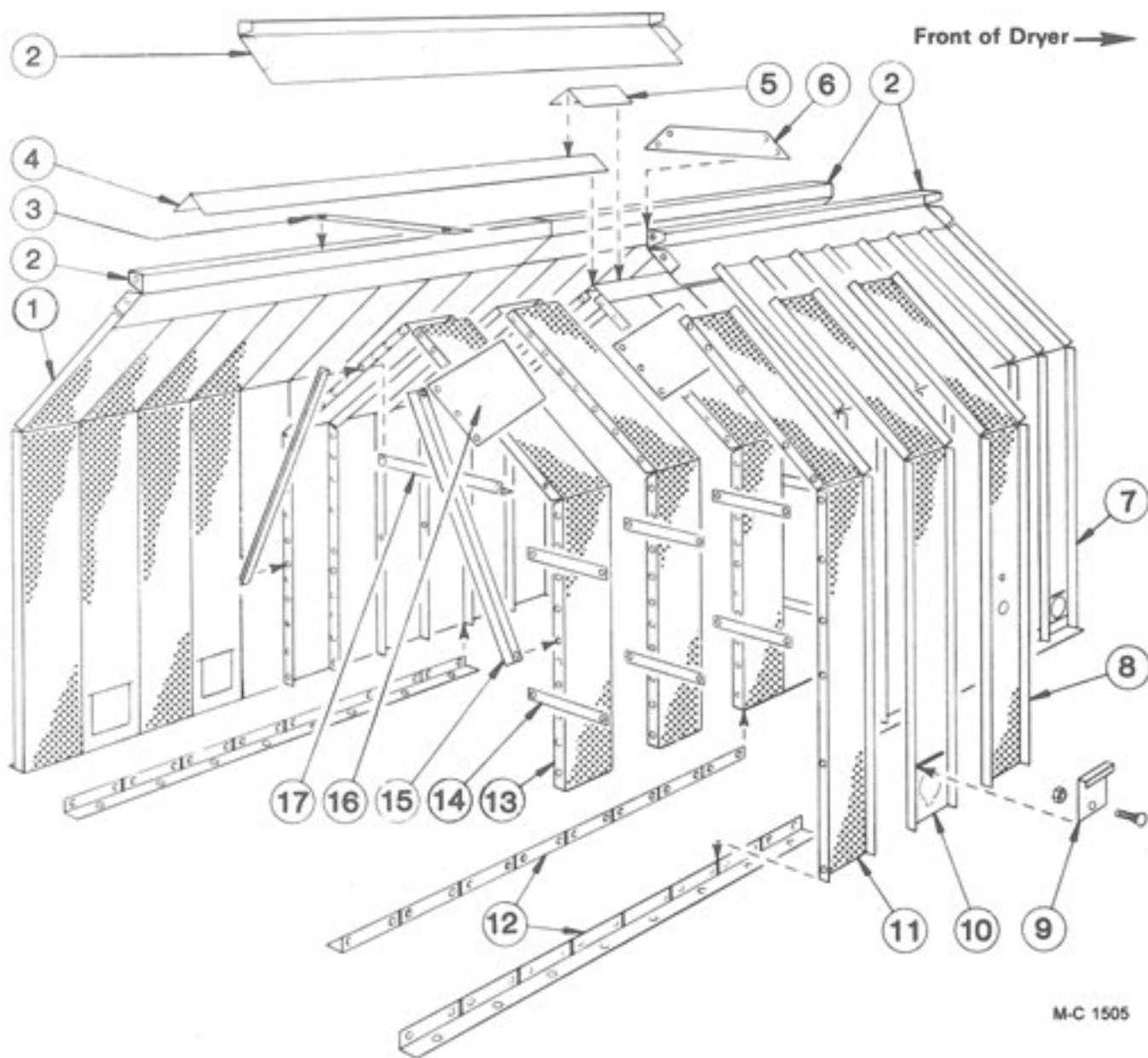

M-C 1505

UPPER SCREENS

Ref.	Part No.	370 570		Description
		Qty	Qty.	
1	----	-	-	Outer End Screen w/o Quick Drain
	021 2946	2	2	Galvanized (Std.)
	127 2967	2	-	Small Screen (Galv.)
	123 5213	2	2	Aluminum
2	129 2832	2	4	Hopper Joiner Angle
3	129 2947	2	2	Stiffener Strap
4	021 2950	1	2	Hopper Cap
5	128 3075	-	1	Seal Angle
6	129 2831	-	1	Joiner Plate
7	----	-	-	Outer End Screen w/Quick Drain
	128 3002	2	2	Galvanized (Std.)
	127 2963	-	-	Small Seed (Galv.)
	123 5210	2	2	Aluminum
8	----	-	-	Moisture Control Screen
	021 2947	1	1	Galvanized (Std.)
	127 2966	-	-	Small Seed (Galv.)
	123 5214	1	1	Aluminum
9	----	-	-	Quick Drain Door
	127 2950	8	16	Galvanized (Std.)
	127 2974	-	16	Small Seed (Galv.)
	001 8269	8,	16	3/8-16 x 3/4" Carriage Bolt
	000 8168	8	16	3/8-16 Flanged Locknut
10	----	-	-	Outer Screen w/Quick Drain
	128 3001	6	14	Galvanized (Std.)
	127 2965	-	14	Small Screen (Galv.)
	123 5212	6	14	Aluminum
11	----	-	-	Outer Screen w/o Quick Drain
	021 2945	5	13	Galvanized (Std.)
	127 2964	-	14	Small Screen (Galv.)
	123 5211	5	13	Aluminum
12	125 2732	4	8	Screen Mount Angle
13	----	-	-	Inner Screen
	021 2949	16	32	Galvanized (Std.)
	127 2968	-	32	Small Seed (Galv.)
14	121 3007	28	60	Stiffener Strap
15	128 2663	6	14	Inner Brace
16	128 3072	6	14	Peak Screen Stiffener
17	021 2600	3	7	Inner Cross Tie

END PANELS AND FLOOR PANELS

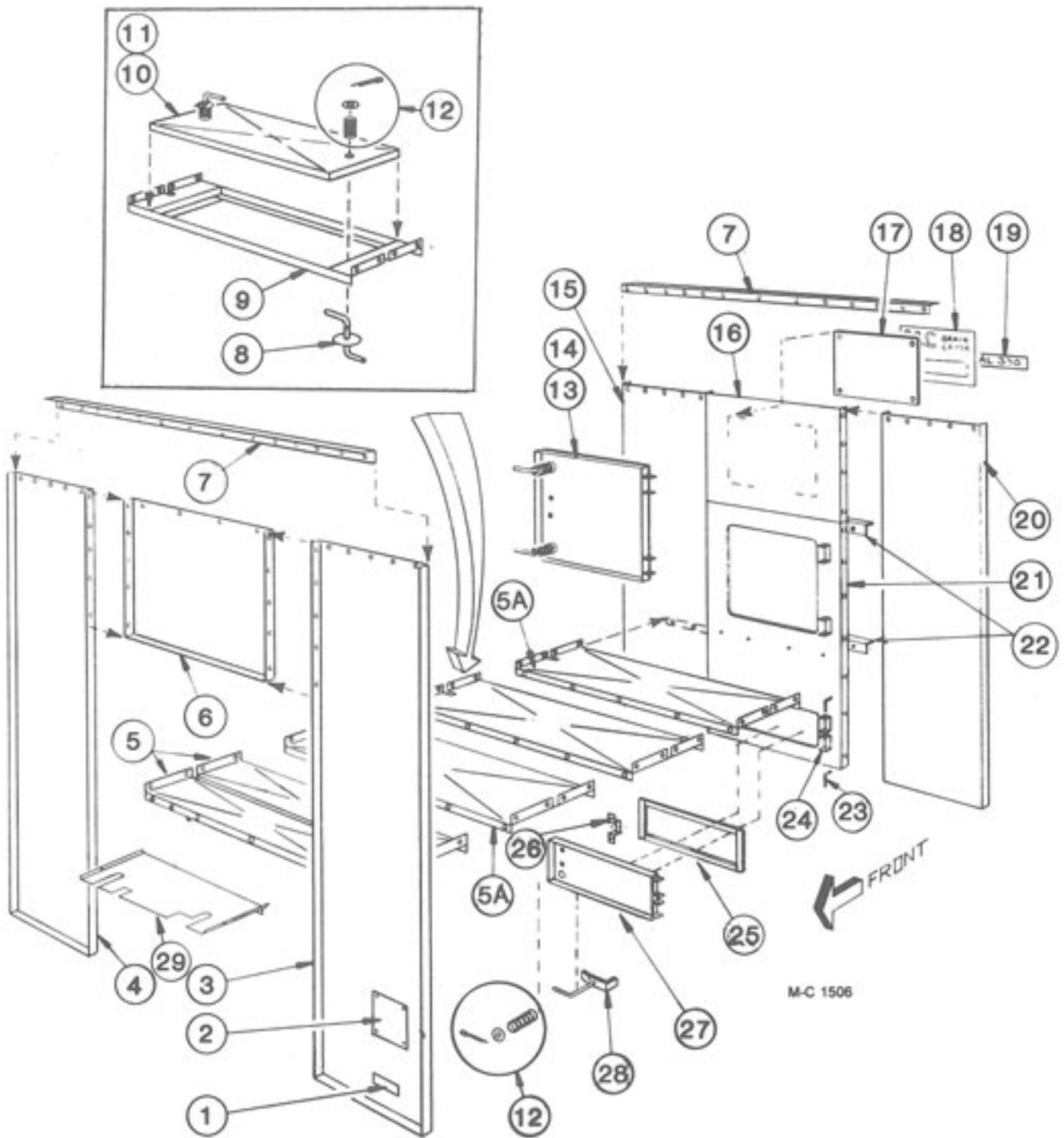

END PANELS AND FLOOR PANELS

Ref.	Part No.	370 570		Description
		Qty	Qty.	
1	121 8310	1	1	"Made in USA" - Decal
2	127 8300	1	1	"CGA" Dryer Plate (Canada Only)
3	124 2836	1	1	Left Front Panel
4	124 2835	1	1	Right Front Panel
5	124 2848	2	2	12" Unit Floor Panel
5A	121 2928	2	6	Unit Floor Panel
6	124 2847	1	1	Panel Above Orifice
7	021 2602	2	2	End Panel to Hopper Joiner Angle
8	121 0302	2	2	Latch and Handle
9	121 0299	1	1	Heat Chamber Door Frame
10	121 1113	1	1	Heat Chamber Door Ass'y (Incl. Ref. 8, 11 & 12)
11	121 2970	1	1	Heat Chamber Door Panel
12	001 8256	-	-	Spring - 5/8" ID x 2"
	000 8174	-	-	3/8" Flatwasher
	000 8199	-	-	1/8" x 1" Cotter Pin
13	128 1183	1	1	Upper Rear Door Ass'y (Incl. Ref. 12, 14, 24, 25, 26 & 28)
14	128 2957	1	1	Upper Rear Door Panel
15	021 2832	1	1	Right Rear End Panel
16	128 2919	1	1	Panel Above Door
17	128 2999	1	1	Decal Mount Plate
18	128 8331	1	1	Large Decal - See note
19	128 8373	1	-	"370" Model Decal
	128 8375	-	1	"570" Model Decal
20	021 2833	1	1	Left Rear End Panel
21	128 2755	1	1	Dryer, Rear Door Frame
22	124 4463	2	2	Brace, Rear Door Frame
23	128 5201	4	4	Hinge Pin
24	128 2740	4	4	Door Hinge
	000 8212	16	16	1/4-20 X 1/2" Truss Hd. Screw
	000 8167	16	16	1/4-20 Flanged Locknut
25	121 8966	10'	10'	Weather Stripping (Order ft. required)
26	121 2887	1	1	Door Handle
27	128 3009	1	1	Lower Door Rear Panel
28	121 0414	3	3	Latch and Handle
29	124 2846	1	1	Burner Unit Floor

NOTE: This decal is imprinted "Model 975." Order one of Ref. 19 to be placed over "Model 975."

SCR DRIVE MOTOR AND GEAR BOX

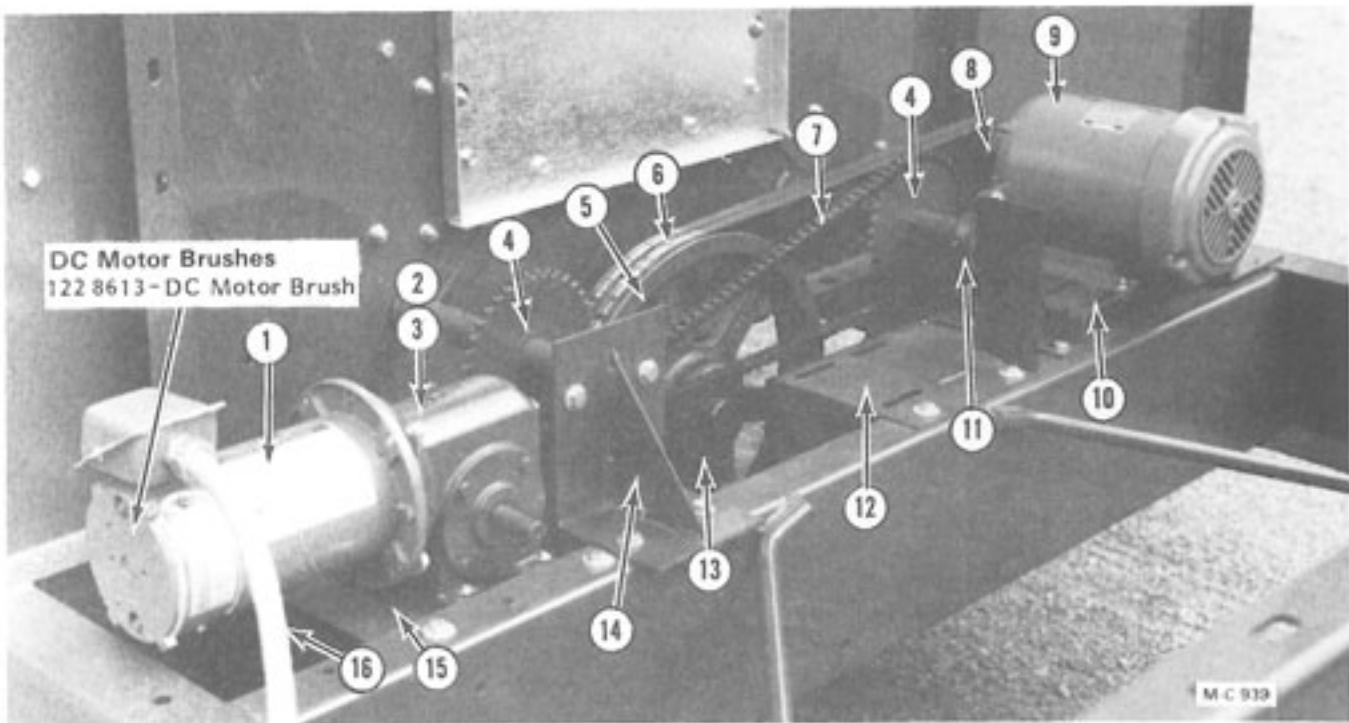

Ref.	Part No.	Qty.	Description
1	124 6837	1	DC Motor - 1/3 HP
	122 8613	-	DC Motor Brush
2	124 6624	1	SCR Gear Box (Incl. 3/16" x 1" Key - 001 5110)
	128 8947	1	Pint of Mobil SHC 634 Oil
	000 8123	5	5/16-16 x 1 1/4" Capscrew
	000 8174	5	5/8" Flatwasher
	000 8168	5	5/8" Flanged Locknut
3	128 6422	1	SCR Gear Box Sprocket (not shown) RC40-12T-3/4" Bore
4	128 6423	2	Sprocket-RC40-36T-1 1/4" Bore
	000 8298	2	Woodruff Key - 1/4" x 3/4"
5	021 6201	1	Pulley-2B x 13.6 SK
	001 5130	1	Key - 3/8" x 1"
6	021 6100	1	B-65 Belts (Matched Set of 2)
7	128 6315	1	Chain - RC-40 x 130 Pitch
	002 6309	-	Connecting Link
8	121 6210	1	Pulley - 2B - 3-3/16" OD - 5/8" Bore
	121 6203	1	Pulley - 2B - 3-3/16" OD - 7/8" Bore

Ref.	Part No.	Qty.	Description
9	127 6860	-	230/460V 1.5HP 3Ø Motor
	121 6861	-	230/460V 2HP 3Ø Motor
	001 5112	1	Key - 3/16" x 1 1/8" (For 1 1/2 HP motor)
	001 5114	1	Key - 3/16" x 1 1/8" (For 2 HP motor)
	128 1810	1	Motor to Cabinet Wire Ass'y
	000 8110	4	5/16-18 x 1 1/2" Capscrew
	000 8108	3	5/16-18 x 1" Capscrew
	000 8173	4	5/16" Flatwasher
	000 8169	4	5/16-18 Flanged Locknut
10	124 4214	1	Unload Auger Motor Mt.
	000 8121	4	5/16-16 x 1" Capscrew
	001 8132	2	5/16-16 x 4" "J" Bolt
	000 8174	5	5/8" Flatwasher
	000 8168	5	5/8" Flanged Locknut
11	121 6022	2	1 1/4" Outboard Brg.
	000 8121	4	5/16-16 x 1" Capscrew
	000 8174	4	5/8" Flatwasher
	000 8168	4	5/8" Flanged Locknut
12	128 0257	1	Gear Mt. Motor Weld.
	000 8119	4	5/16-16 x 3/4" Capscrew
	000 8174	4	5/8" Flatwasher
	000 8168	4	5/8" Flanged Locknut

Continued on next page

SCR DRIVE MOTOR AND GEAR BOX

Ref.	Part No.	Qty.	Description
13	001 6202	1	SK Bushing - 1-7/16" Bore (Incl. capscrews)
14	128 0191	1	Outboard Bearing Mount
15	124 4456	1	Gear Box Mount
	000 8119	4	3/8-16 x 3/4" Capscrew
	000 8174	4	3/8" Flatwasher
	000 8168	4	3/8-16 Flanged Locknut
16	128 1999	1	SCR Motor to Cabinet Flexible Conduit (40")
17	128 0268	1	Drive Guard
	128 8951	2	Rubber Strap w/Hook
	001 3302	2	Angle Clip
	000 8121	4	3/8-16 x 1" Capscrew
	000 8174	6	3/8" Flatwasher
	001 8149	4	3/8-16 Two-Way Locknut

Not Shown:

18	000 8301	2	Safety Shield Warning Decal
-	120 6914	2	Chase Nipple - 1/2"
-	121 6906	2	Pipe Clamp
	000 8212	2	1/4-20 x 1/2" Truss Hd. Screw
	000 8167	2	1/4-20 Flanged Locknut

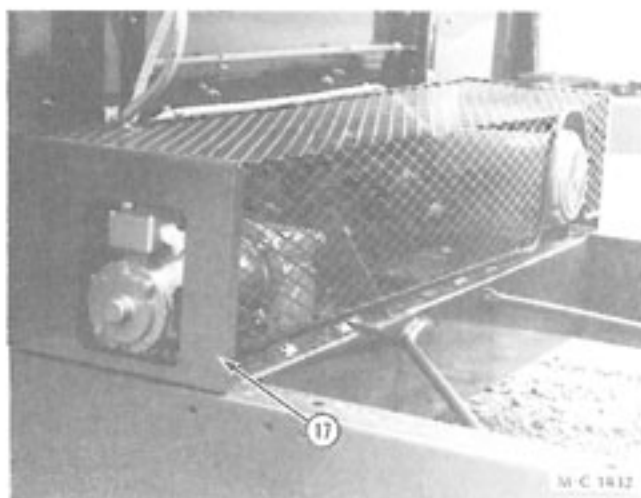

FAN ORIFICE AND ORIFICE LINER

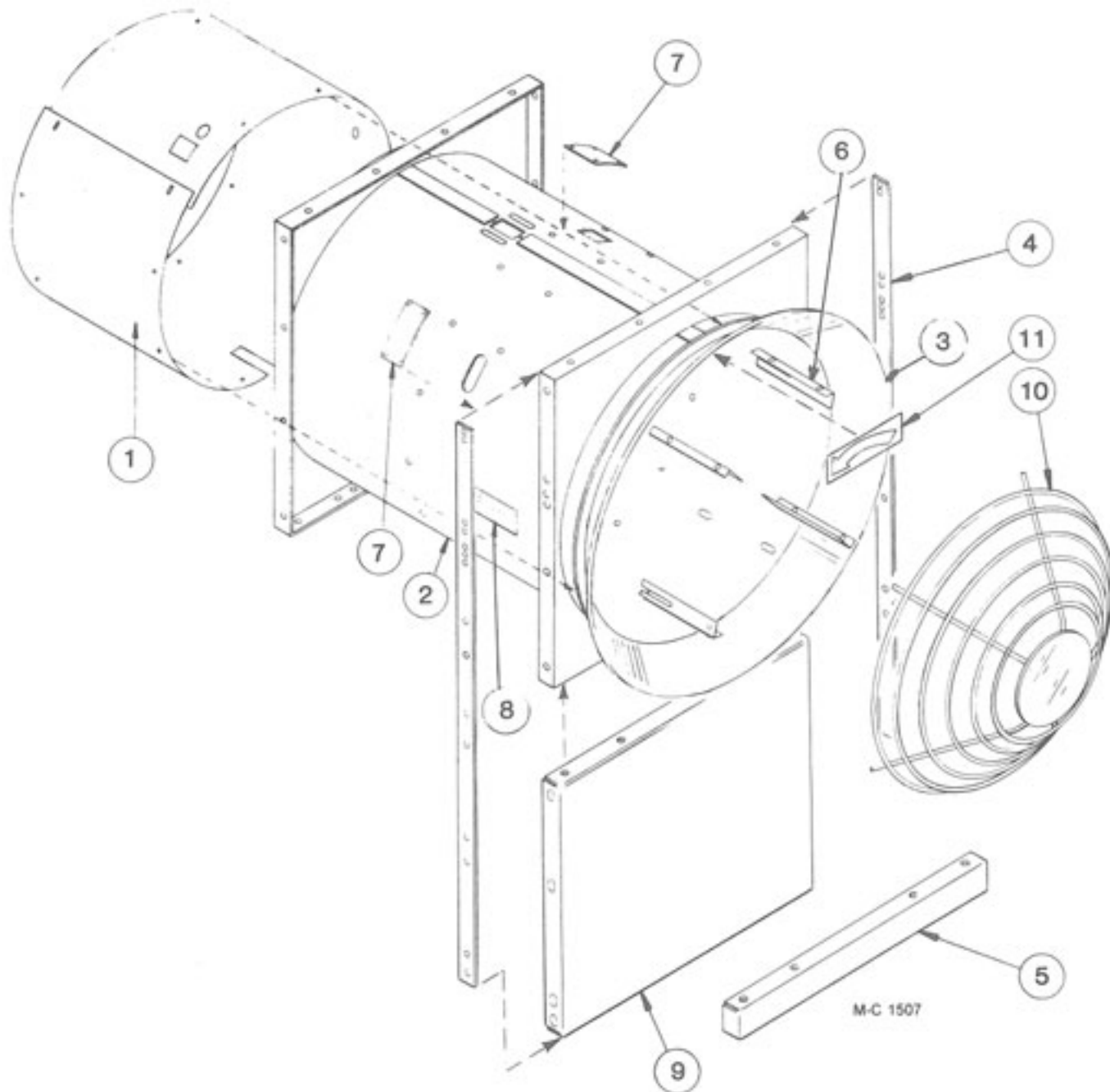

FAN ORIFICE, ORIFICE LINER AND GUARD

Ref. Part No.	Qty.	Description	Ref. Part No.	Qty.	Description		
1	128 4725	1	Orifice Liner	6	128 2756	4	Air Flow Straightener
2	128 0267	1	Fan Orifice Weldment	7	121 2978	2	Orifice Cover Plate
3	121 8998	1	Intake Flange Spinning	8	128 8363	1	Vaporizer Adj. Decal (LP Gas)
4	128 3465	2	Fan Housing Brace	9	128 4570	1	Spacer Panel
5	128 0272	1	Orifice Support Weldment	10	121 8956	1	Fan Guard
				11	121 8301	1	Counterclockwise Arrow

BURNER ASSEMBLY

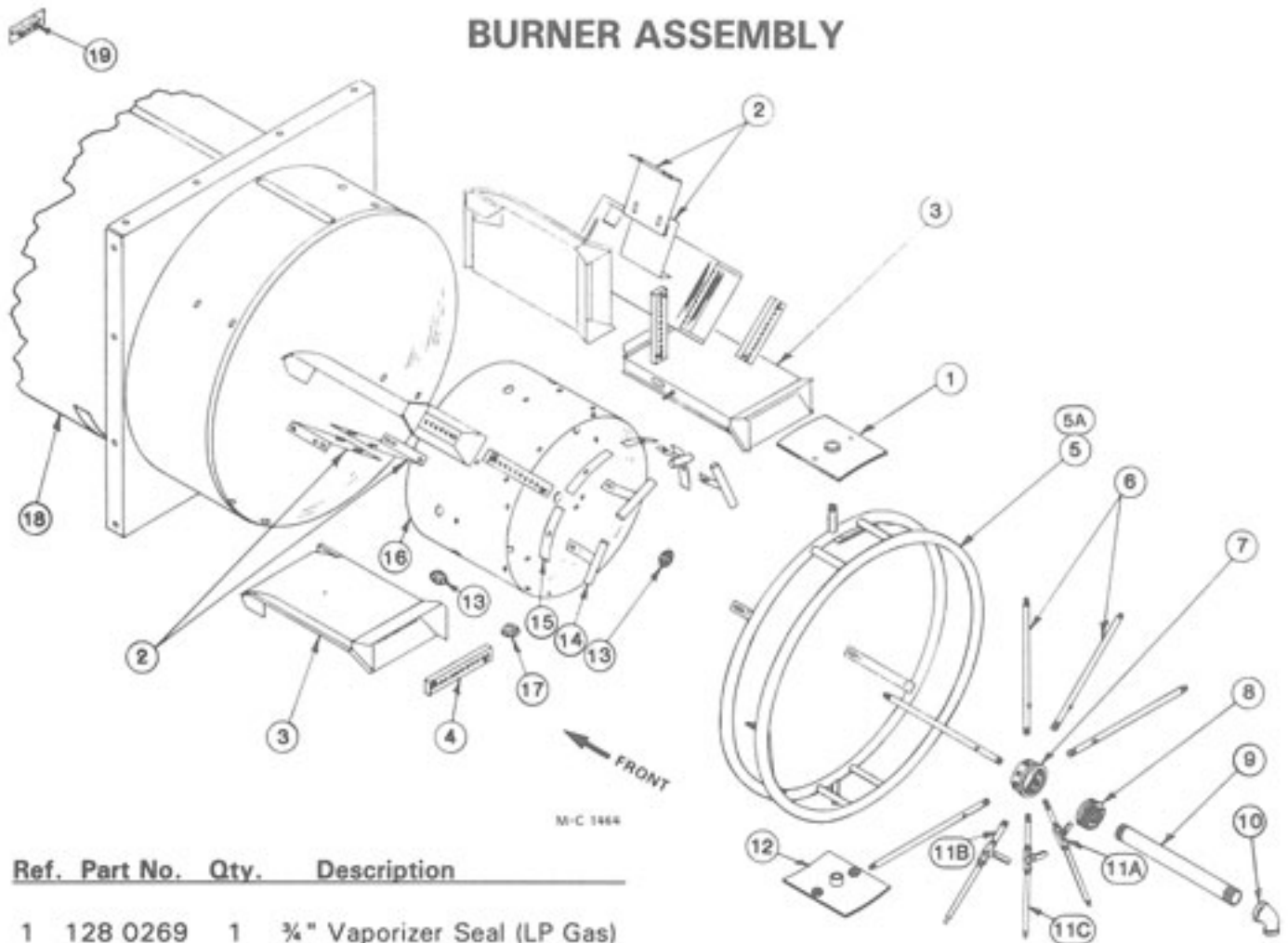

Ref.	Part No.	Qty.	Description
------	----------	------	-------------

1	128 0269	1	3/4" Vaporizer Seal (LP Gas)
2	121 4867	8	Air Chamber Mtg. Brkt.
	000 8106	8	5/16"-18 x 3/4" Capscrew
	000 8103	16	5/16"-18 x 1/2" Truss Hd. Screw
	000 8173	8	5/16" Flatwasher
	000 8169	24	5/16-18 Flanged Locknut
3	121 1241	8	Burner Unit (Incl. Ref. 4)
	000 8169	8	5/16-18 Flanged Locknut
4	121 5988	8	Burner Insert
	000 8261	16	1/4 x 1" Sheet Metal Screw
5	128 0304	1	Vaporizer Ring (570)
5A	128 0294	1	Vaporizer Ring (370) (Not Shown)
	000 8104	4	5/16"-18 x 3/4" Truss Hd.
	000 8169	4	5/16-18 Flanged Locknut
6	-----	-	Burner Lead Tube
	124 5701	5	1/8" Orifice - LP Gas (370)
	121 5987	5	3/16" Orifice - Nat. Gas (570)
	128 5926	5	5/32" Orifice - Nat. Gas (370)
	128 5926	5	5/32" Orifice - LP Gas (570)
7	121 5501	1	Burner Head
8	121 5738	1	3" to 1 1/4" Reducing Bushing
9	123 8073	1	1 1/4" x 6 1/2" Std. Nipple
10	123 8049	1	1 1/4" to 3/4" - 90° Std. Reducing Elbow (LP Gas)

Ref.	Part No.	Qty.	Description
------	----------	------	-------------

11A	127 8044	3	3/8" Valve Cock w/Handle
11B	128 7512	3	3/8" Std. Blk. Pipe 4 1/2"
11C	128 5920	3	1/8" Orifice - LP Gas (370)
	128 5925	3	3/16" Orifice - Nat. Gas (570)
	128 5924	3	5/32" Orifice - Nat. Gas (370)
	128 5924	3	5/32" Orifice - LP Gas (570)
12	128 0270	1	1/2" Vaporizer Seal
13	128 6858	3	3/4" Steel Knock-Out Plug
14	121 0316	4	Ignition Tube
	000 8104	4	5/16"-18 x 3/4" Truss Hd. Screw
	000 8169	4	5/16-18 Flanged Locknut
15	121 4468	8	Burner Locator Strip
16	121 0322	1	Burner Center Tube
17	121 6917	1	1/2" Steel Knock-Out Plug
18	128 0267	1	Fan Orifice Weld.
19	121 8301	1	Counterclockwise Arrow Decal

FAN AND FAN MOTOR MOUNT

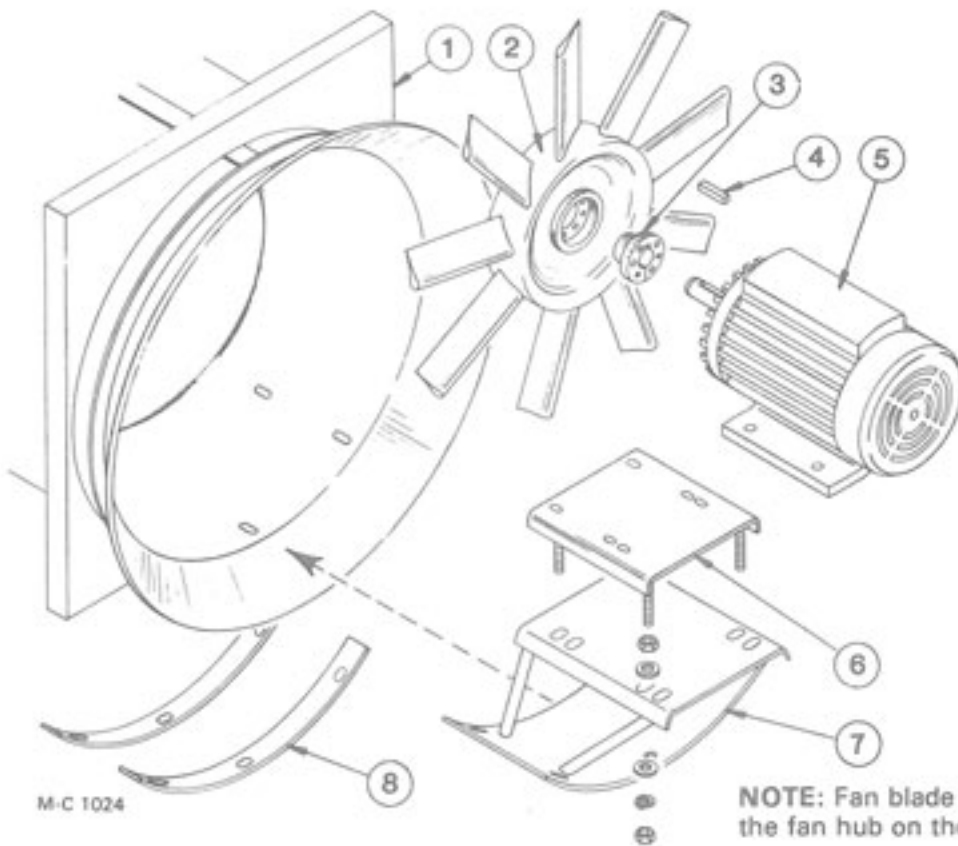

M-C 1024

NOTE: Fan blade pitch in degrees is stamped on the fan hub on the side opposite the bushing.

Ref.	Part No.	Qty.	Description
1	128 0267	1	Fan Orifice Weld
2	-----	-	Fan
	121 0337	1	370 (9 blade 18°)
	121 0272	1	570 (9 blade 27°)
3	121 6239	-	"SK" Bushing - 1 1/8" Bore (10HP motors)
	121 6229	-	"SK" Bushing - 1 1/8" Bore (20HP motors)
	121 8117	3	5/16-18 x 2" Socket Hd. Capscrew - Grd. 5
4	001 5124	1	Key - 5/16" x 2 3/8" (10HP motor)
	001 5139	1	Key - 3/8" x 3" (20HP motor)
5	-----	-	Fan Motor
	124 6818	1	10HP 1Ø 230V Motor (370)
	201 6818	1	10HP 3Ø 230/460V Motor (370)

Ref.	Part No.	Qty.	Description
	124 6879	1	20HP 1Ø 230V Motor (570)
	125 6934	1	20HP 3Ø 230/460V Motor (570)
	000 8293	4	3/8"-16 x 1 1/2" Capscrew Full Thread (10HP motor)
	000 8168	4	3/8"-16 Flanged Locknut
	000 8139	4	1/2"-13 x 1 1/4" Capscrew (20HP motor)
	000 8170	4	1/2"-13 Flanged Locknut
6	121 0343	1	Motor Mt. (20HP motor)
	000 8165	8	3/4"-10 Hex Nut
	000 8177	8	3/4" Flatwasher
	000 8182	4	3/4" Lockwasher
7	121 0258	1	Motor Mt. Base
	000 8139	4	1/2"-13 x 1" Carriage Bolt
	000 8170	4	1/2"-13 Flanged Locknut
8	121 3356	2	Orifice Reinforcement

ELECTRODE AND FLAME SENSING PROBE

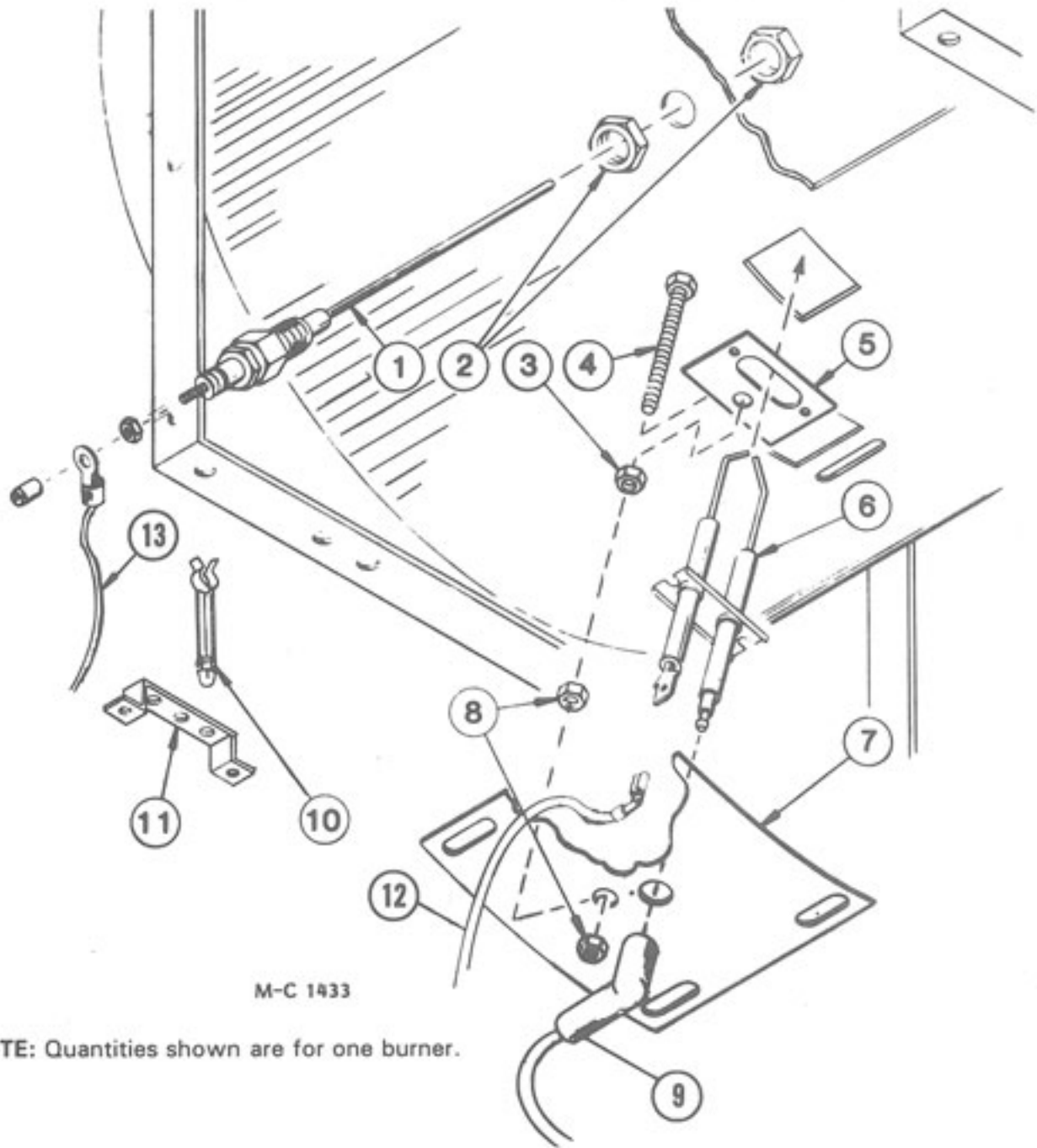

M-C 1433

NOTE: Quantities shown are for one burner.

Ref. Part No.	Qty.	Description	Ref. Part No.	Qty.	Description		
1	124 6872	1	Flame Sensing Probe	7	128 2747	1	Electrode Mt. Seal
2	121 6915	2	Locknut - 1/2"	001 8104	4	1/4-20 x 1/2" Self-Tapping Screw	
3	000 8162	1	3/8-16 Hex Nut	8	000 8168	2	3/8-16 Flanged Locknut
4	000 8227	1	3/8-16 X 2 3/4" Capscrew - Full Thread	9	128 1910	1	Ignition Wire 36" w/Boot
5	128 2746	1	Electrode Mt. Plate	10	128 6989	3	Stand-Off Clip
6	128 6995	1	Style 2 Electrode	11	128 4941	1	Wire Support Brkt. (On bottom burner)
	000 8186	2	6-32 x 1/2" Machine Screw	12	124 1078	1	Low Voltage Wire Ass'y 36"
	000 8245	2	No. 6 Lockwasher	13	124 1077	1	Low Voltage Wire Ass'y 48"
	000 8185	2	6-32 Flanged Locknut				

LP GAS MANIFOLD

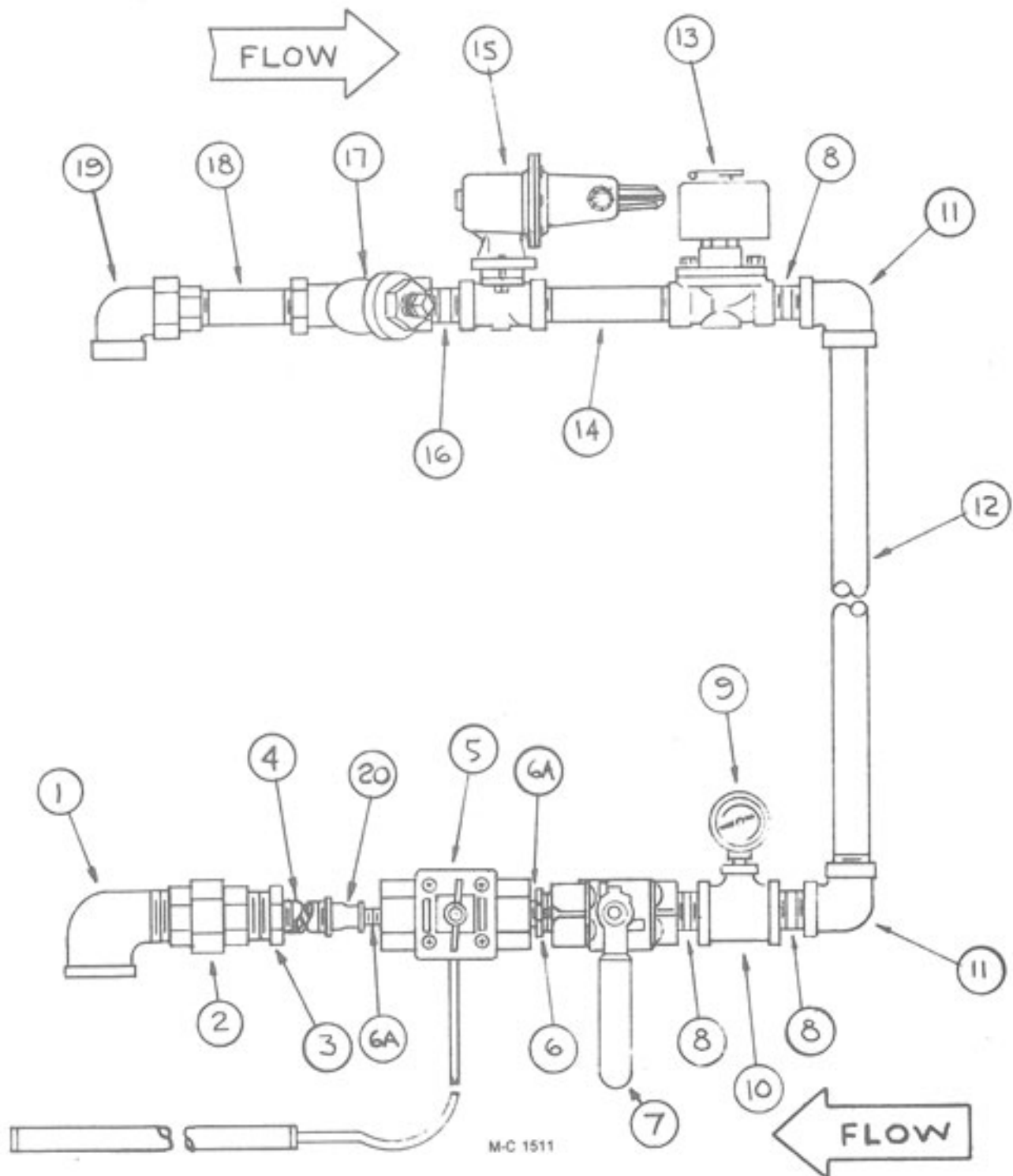

LP GAS MANIFOLD

Ref.	Part No.	Qty.	Description
1	123 8062	1	1 ¼" - 90° Street Elbow
2	123 8053	1	1 ¼" Standard Union
3	123 8078	1	1 ¼" x ¾" Reducer Bushing
4	121 8008	1	¾" x 3" Extra Heavy Nipple
5	121 7024	1	½" Modulating Valve 140°-250° P.E.
6	121 8029	1	¾" x ½" Reducer Bushing
6A	121 8013	2	½" Close Nipple
7	121 7011	1	¾" Hand Valve
8	121 8007	3	¾" Close Nipple
9	120 7002	1	Pressure Gauge
10	123 8092	1	¾" x ¾" x ¾" Standard Tee
11	121 8074	2	¾" - 90° Standard Elbow
12	129 8037	1	¾" x 10" Standard Nipple
13	121 7002	1	¾" Solenoid Valve 115V
14	127 8008	1	¾" x 6" Standard Nipple
15	128 7005	1	LP Gas Pressure Regulator
16	121 8005	1	¾" x 1 ½" Extra Heavy Nipple
17	121 8060	1	¾" Strainer
18	125 8058	1	¾" x 2 ½" Extra Heavy Nipple
19	128 8019	1	¾" Extra Heavy Union Elbow
20	128 8041	1	¾" x ½" Red. Coupling Extra Heavy

LP LIQUID LINE

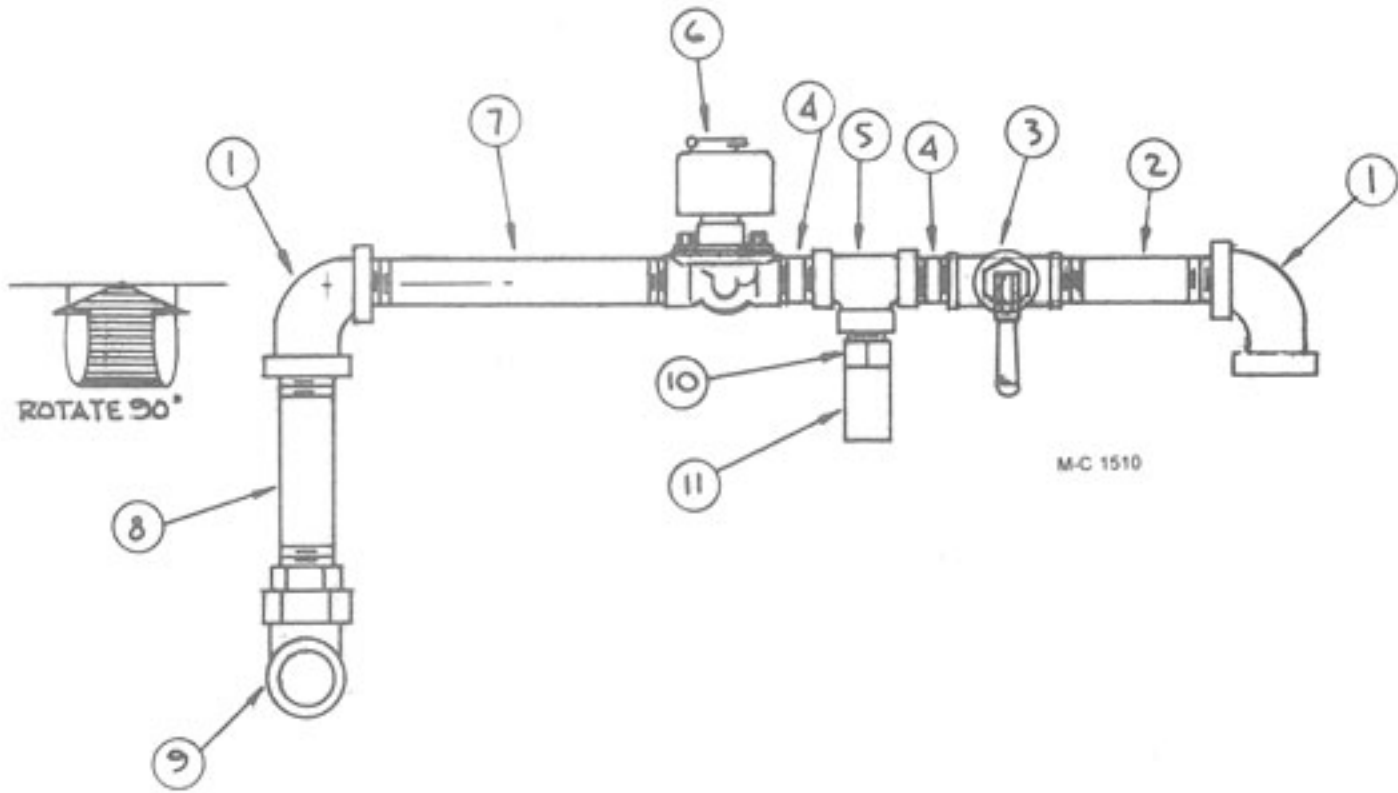

Ref.	Part No.	Qty.	Description
1	121 8036	2	½" X 90° Elbow Extra Heavy
2	121 8014	1	½" x 5" Extra Heavy Nipple
3	121 7015	1	Flip Valve
4	121 8094	2	½" x 1 ½" Extra Heavy Nipple
5	120 8035	1	½" Tee Extra Heavy
6	125 7082	1	½" Solenoid Valve
7	125 8010	1	½" Extra Heavy x 10" Nipple
8	121 8064	1	½" x 7" Extra Heavy Nipple
9	128 8010	1	½" Extra Heavy Union Elbow
10	121 7014	1	Relief Valve Adapter
11	121 7013	1	Relief Valve

NATURAL GAS MANIFOLD

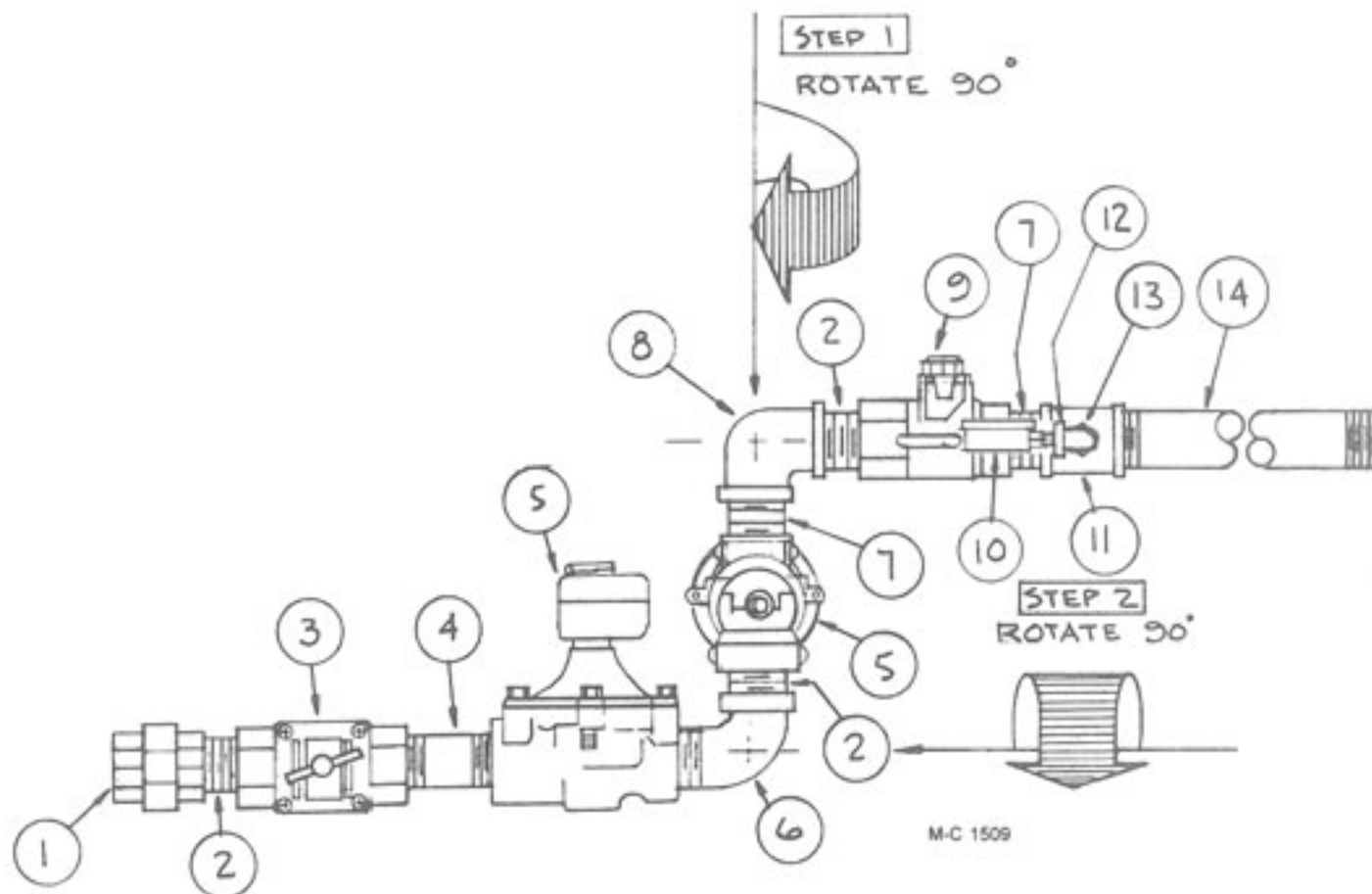

Ref.	Part No.	Qty.	Description
1	123 8053	1	1 1/4" Standard Union
2	123 8069	3	1 1/4" Standard Close Nipple
3	123 7024	1	1 1/4" Modulating Valve 140°-250°
4	128 8003	1	1 1/4" x 3 1/2" Standard Nipple
5	128 7001	2	1 1/4" Solenoid Valve
6	123 8062	1	1 1/4" Street Elbow
7	125 8013	2	1 1/4" X 2" Standard Nipple
8	123 8051	1	1 1/4" - 90° Standard Elbow
9	123 7003	1	1 1/4" Hand Valve
10	120 7002	1	Gas Pressure Gauge
11	127 8131	1	1 1/4" x 1 1/4" x 3/8" Standard Tee
12	121 8039	1	1/4" 90° Street Elbow
13	127 8132	1	3/8" to 1/4" Reducer
14	127 8025	1	1 1/4" x 36" Standard Nipple

115 V AND MOTOR CONTROL CABINET

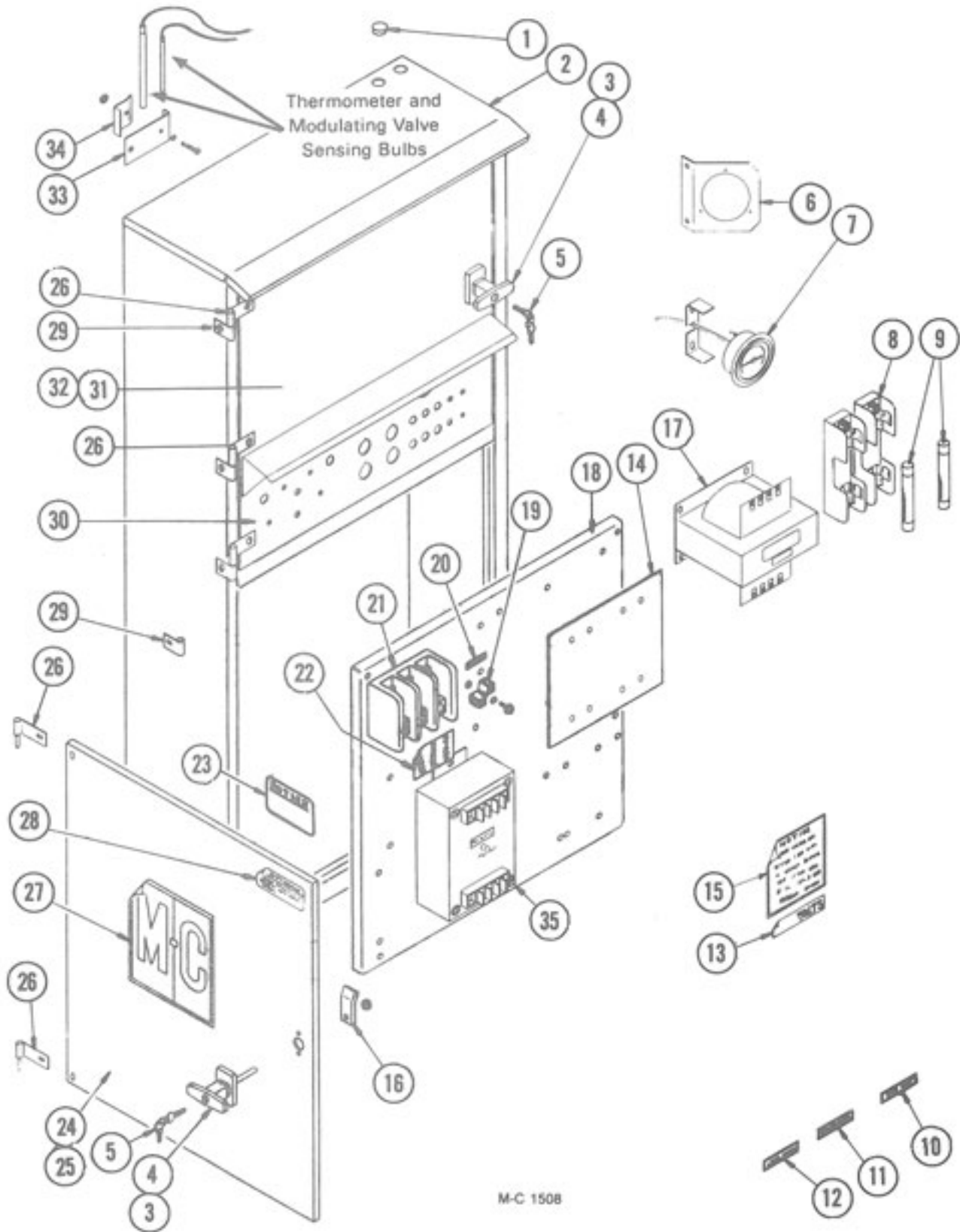

115 V AND MOTOR CONTROL CABINET

Ref. Part No.	Qty.	Description	Ref. Part No.	Qty.	Description		
1	121 8600	1	Hole Plug	15	121 8315	1	Notice, Warranty Decal
2	128 0307	1	Control Cabinet Weld	16	128 3425	2	Door Handle Cam
	128 8600	-	Weather Stripping - ¼" x ½" (Specify ft. reqd.)	17	127 6855	1	200/208V Transformer (750VA)
					127 6827	1	230/460V Transformer (750VA)
3	124 1021	2	Door "T" Handle Ass'y (Incl. Ref. 5 keys, Ref. 16 cam and mtg. hdwe.) Lever type handle no longer available.		127 6829	1	230/460/575V Trans- former (750VA)
4	128 8946	2	Door "T" Handle w/keys (Less Ref. 16 cam)	18	124 4453	1	Component Mtg. Panel
5	122 8900	2	Door "T" Handle Key	19	125 6918	2	Grounding Lug
6	124 4824	1	Thermometer Mt. Plate	20	128 8349	1	Ground Decal
7	128 8983	1	Thermometer - 15' Capillary (Mtg. brkt. incl.)	21	128 6957	1	Splitter Block-1 & 3 Phase
8	121 6988	2	Fuse Holder (208V, 460V & 575V)	22	128 8318	1	Splitter Block Voltage Decal
9	124 6835	2	208V Fuse - FRN9	23	001 8310	1	Machine Warranty Decal
	124 6829	2	460V Fuse - FRS4	24	128 1930	1	Lower Door Ass'y (Incl. Ref. 3, 16 & 25 thru 28)
	127 6839	2	575V Fuse - FRS3.2	25	124 4816	1	Door - Lower
10	121 8313	1	Heat Fan Decal	26	021 0012	4	Door Hinge w/Pin
11	128 8335	1	Unload Auger Decal	27	001 8302	1	M-C Decal - 8-3/16" x 9"
12	121 8351	1	Level Auger Decal	28	121 8316	1	Dryer Warning Decal
13	123 8339	1	208 Volts Decal	29	121 4656	6	Door Hinge w/o Pin
	123 8336	1	230 Volts Decal	30	128 0278	1	Hinged Light Door
	123 8335	1	460 Volts Decal	31	128 1908	1	Upper Door Ass'y (Incl. Ref. 3, 16, 26 & 32)
	123 8338	1	575 Volts Decal	32	021 4769	1	Door - Upper
14	128 5789	2	Insulator Sheet (460V & 575V)	33	121 2883	-	Sensing Bulb Brkt.
				34	121 2882	-	Sensing Bulb Clip
				35	124 6947	1	Motor Saver (20HP 1Ø only)

Not Shown:

128 2676 2 Cabinet Extension

ELECTRICAL COMPONENTS IN 115V CONTROL CABINET

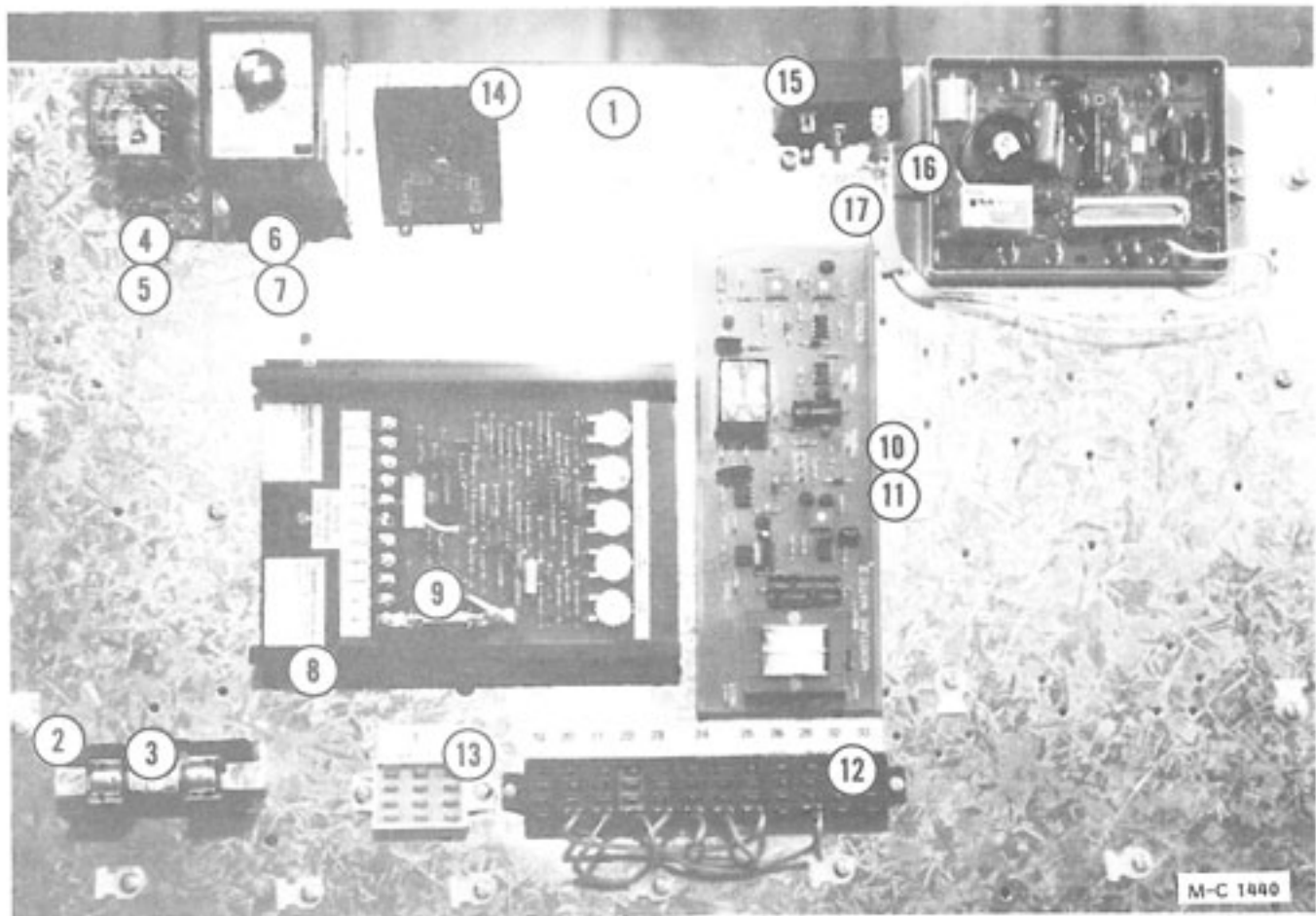

Ref.	Part No.	Description
1	021 4770	Component Mounting Board
2	128 6851	Fuse Holder
3	128 6967	10 Amp Fuse (NON-10)
4	021 6810	Relay Socket
5	021 6809	Relay
6	021 6816	Timer Socket
7	021 6815	60 Minute Adjustable Timer
8	124 6874	SCR Board (Dart)
9	121 6805	10 Amp - GLH Fuse
10	124 6940	Moisture-Matic II
11	128 5916	Snap Track 8 1/2"
12	124 6928	Terminal Block 12-Position
13	124 6929	Terminal Block 3-Position
14	124 6890	Adjustable .01-8 Min. Timer
15	124 6831	10 Second Timer
16	121 6925	Ignition Board
17	127 6812	10W 3K Resistor

CONTROL PANEL LIGHTS, SWITCHES AND CONTROLS

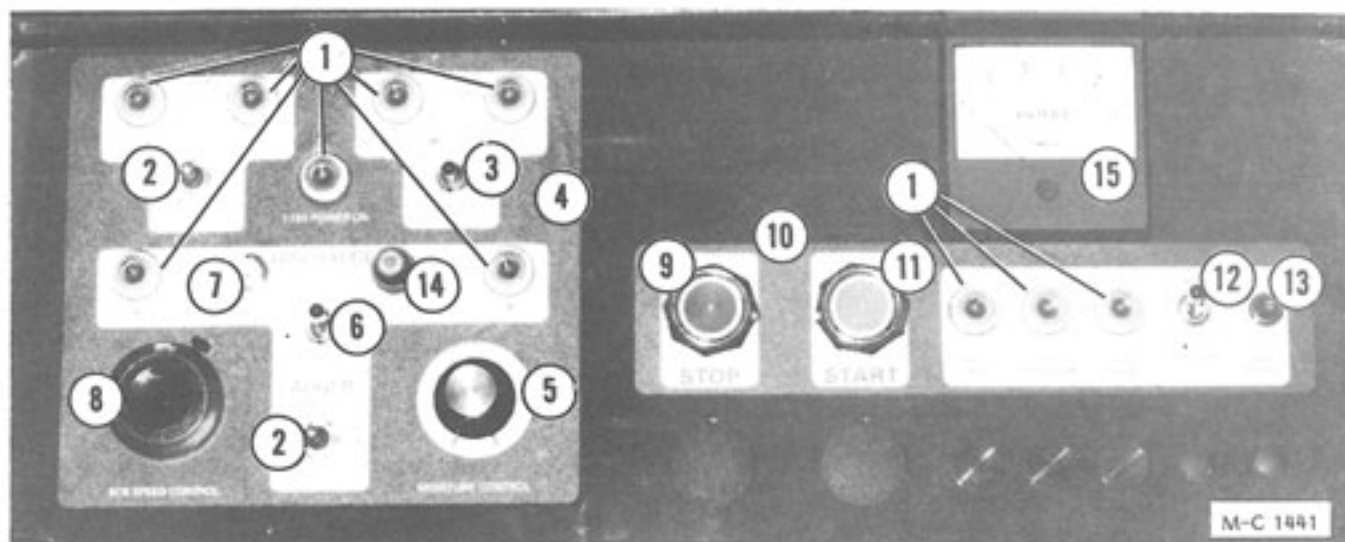

Ref.	Part No.	Description
1	121 6808	125V Indicator Lamp Ass'y (Inc. lamp & lens)
	122 6810	125V Indicator Lamp
	122 6800	Indicator Lamp Lens (Clear)
2	120 6827	OFF-ON-ON Momentary Contact Toggle Switch
3	121 6807	ON-OFF-ON Toggle Switch (DPDT)
4	128 8365	115V Control Bezel
5	124 6939	Moisture Control Potentiometer w/Knob & Wire
	124 6941	Knob
6	121 6807	ON-OFF-ON Toggle Switch (DPDT)
7	124 6848	8 Amp Circuit Breaker (SCR Drive)
8	124 1089	SCR Drive Potentiometer (10 turn w/wire)
	124 6892	Multi-Dial
9	128 6845	Stop Button - Red
10	128 8358	Fan Control Bezel
11	128 6844	Start Button - Black
12	121 6815	ON-OFF Toggle Switch (SPST)
13	122 6814	Ignition Reset (0.1 Amp)
14	124 6938	Fuse Holder
	124 6937	1 Amp Fuse Slo-Blow
15	124 6936	Discharge Meter
	124 1081	Resistor Assembly

570 HOPPER AND LEVEL AUGER

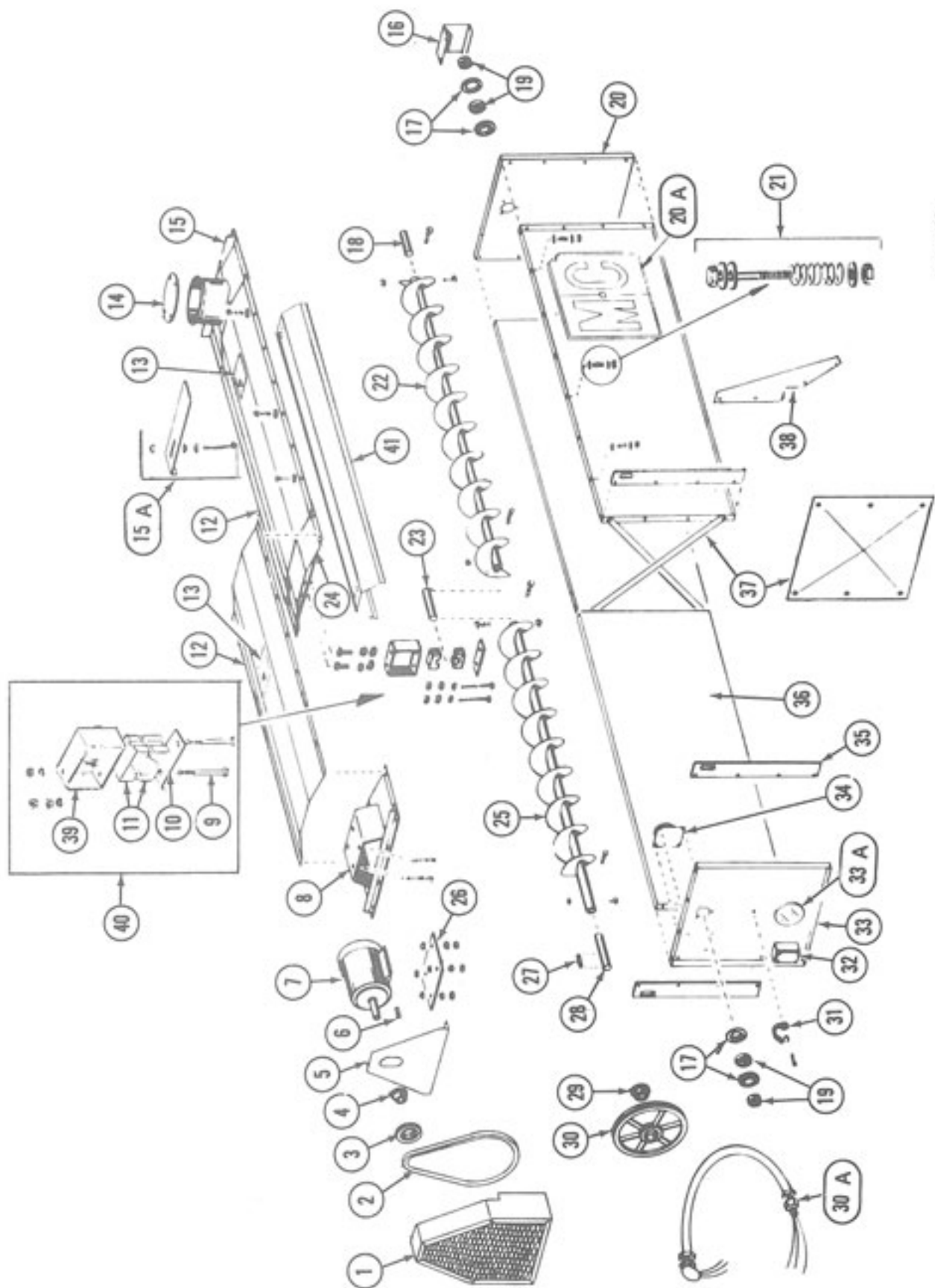

M-C 1502

570 HOPPER AND LEVEL AUGER

Ref.	Part No.	Qty.	Description	Ref.	Part No.	Qty.	Description
1	129 0003	1	Level Auger Guard	22	128 0122	1	Level Auger (93 1/2" RH flighting)
2	128 6103	1	Level Auger Belt 2/3V/710 (banded belt) or 128 6104 in matched set of two	23	128 5050	1	Level Auger Center Shaft (1 1/4" x 10 1/4")
3	128 6207	1	Level Auger Motor Sheave "SH" 3V/3.65 x 2 Grv.	24	129 0000	1	Level Auger Support
4	128 6214	1	Level Auger Motor Bushing - 1 1/8" SH Bushing for 3HP & 5HP motor (Incl. capscrews & lockwashers)	25	128 0317	1	Level Auger (82 3/8" RH flighting)
5	129 4944	1	Level Auger Guard Back	26	129 4202	1	Level Auger Motor Mt. Plate
6	001 5112	1	Key - 3/16" x 1 1/8" (1.5HP motor)	000 8161	4	1/2-13 x 3 1/2" Capscrew (Full thread)	
001 5114	1	Key - 3/16" x 1 1/8" (2HP motor)	000 8170	4	1/2-13 Flanged Locknut		
001 5119	-	-	Key - 1/4" x 2" (3HP motor)	000 8163	8	1/2-13 Hex Nut	
7	128 6818	1	230/460V 3HP 3Ø Motor	27	001 5120	1	Key - 1/4" x 1 1/2"
8	129 0001	1	Level Auger Motor Mt.	28	128 5051	1	Level Auger Front Shaft (1 1/4" x 10")
9	001 8287	2	3/8-16 x 3 3/4" Capscrew - Grd. 5	29	121 6241	1	1 1/4" SK Bushing (Incl. capscrews & lockwashers)
001 8139	2	3/8" Lockwasher	30	128 6208	-	Level Auger Sheave "SK" 3V/19.0 x 2 Grv.	
000 8162	8	3/8-16 Hex Nut	30A	128 1960	1	Flexible Conduit w/Wires	
10	128 3415	2	Bearing Hanger Bar	31	128 8951	1	Rubber Strap w/Hook
11	128 6021	1	Wood Bearing - 1 1/4" (2 halves)	32	128 6922	1	Slatter Box (1/2")
12	129 2945	2	Hopper Cover - Front & Rear (76")	33	129 2835	1	Upper End Panel - Front
13	128 8355	2	Warning Decal	33A	129 5702	1	Port View Lens
14	129 4204	1	Receiving Tube Cover	34	128 6992	1	Bin Level Indicator (See pg. 31)
15	129 0002	1	Receiving Hopper	35	129 3412	4	Lifting Bar
15A	129 4205	1	Flow Restrictor	36	129 2836	4	Hopper Side
129 5703	1	Position & Locking Bolt	37	129 2948	2	Cross Strap (37")	
000 8168	3	3/8-16 Flanged Locknut	38	129 2715	2	Hopper Panel Brace	
129 4947	1	Stub Guard	39	129 2603	6	Hopper Brace	
001 6004	4	Bearing Flangette 1 1/4"	001 8135	2	Level Auger Brg. Support		
128 5052	1	Level Auger Rear Shaft (1 1/4" x 8")	001 8139	2	3/8-16 x 1" Capscrew - Grd. 5		
001 6003	2	Bearing w/Lock Collar - 1 1/4"	000 8162	2	3/8" Lockwasher		
129 2834	1	Upper End Panel - Rear	000 8162	2	3/8-16 Hex Nut		
121 8343	2	M-C Decal (26 1/2" x 23")	40	122 1008	1	Level Auger Brg. Kit (Incl. Ref. 10, 11, 39 & 40 in quantities reqd. for one brg.)	
000 8101	12	1/4-20 x 2" Capscrew	41	129 2838	1	Auger Cover Short	
131 8708	12	Spring (5/8" OD x 1 3/4")					
000 8172	36	1/4" Flatwasher					
000 8210	12	1/4-20 Two-Way Locknut					

370 HOPPER AND HOPPER EXTENSION

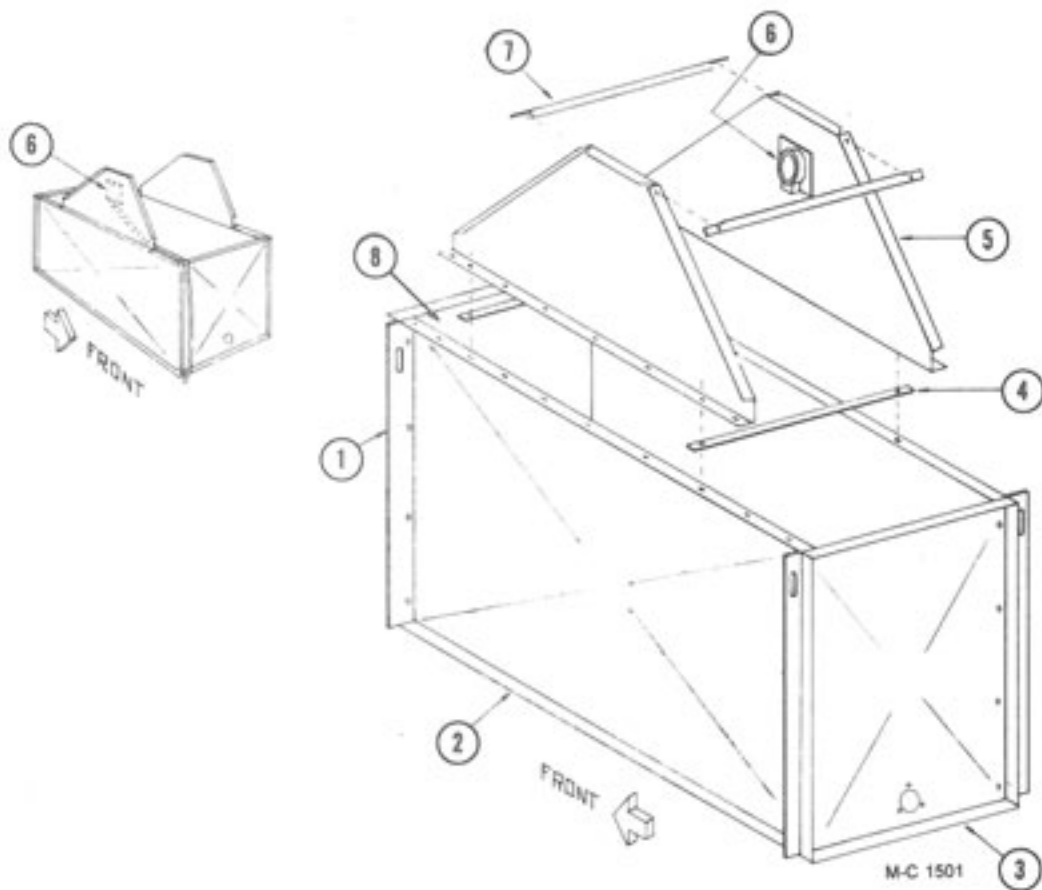

Ref.	Part No.	Qty.	Description
1	129 3412	4	Lifting Bar
2	129 2836	2	Hopper Side
3	129 4950	1	Rear Hopper End Panel
4	129 2948	2	Cross Strap
5	128 4973	2	Hopper Extension Angle
6	128 6992	1	Bin Level Indicator
7	124 4458	2	Hopper Extension Angle
8	129 4951	1	Front Hopper End Panel

MOISTURE CONTROL, AIR PRESSURE AND HIGH LIMIT SWITCHES

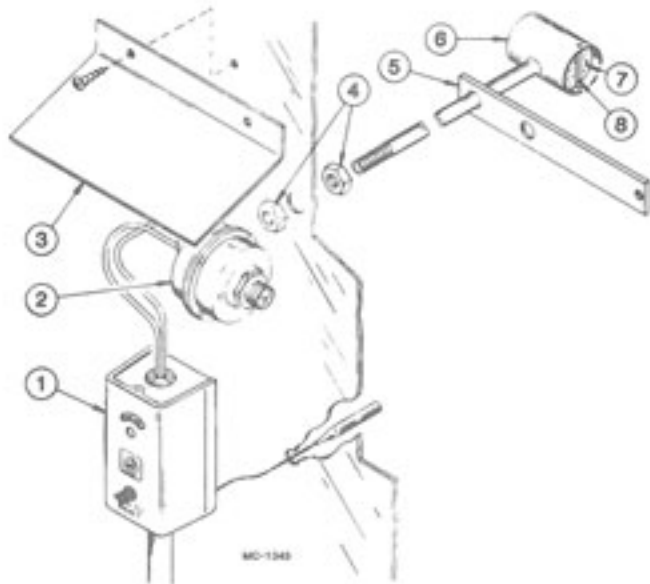

Air Pressure and High Limit Switches

Ref.	Part No.	Description
1	124 6934	High Limit Switch - Adjustable-Manual Reset
2	121 6849	Air Pressure Switch
3	121 2946	High Limit Switch Cover
4	121 8000	Pipe Locknut - 1/4"
5	121 2007	Air Pressure Tube Brkt.
6	121 0169	Air Pressure Tube
7	121 5716	Air Pressure Tube Filter
8	-----	Filter Retainer (Wire)

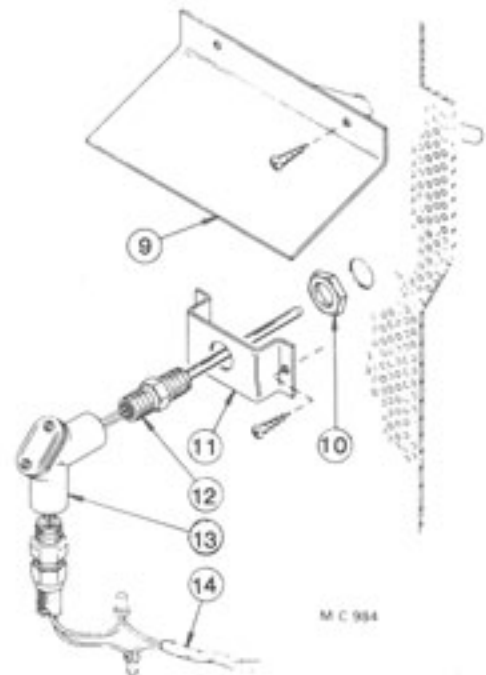

Moisture Control Probe

Ref.	Part No.	Description
9	121 0031	Moisture Control Shield
10	121 6915	Locknut - 1/2"
11	128 3007	Bracket
12	124 6893	Thermistor Sensor (Probe)
13	123 8089	1/2" Handy Ell
14	125 6908	18/2 PVC Cord w/Shield

LEVEL SWITCH ASSEMBLY

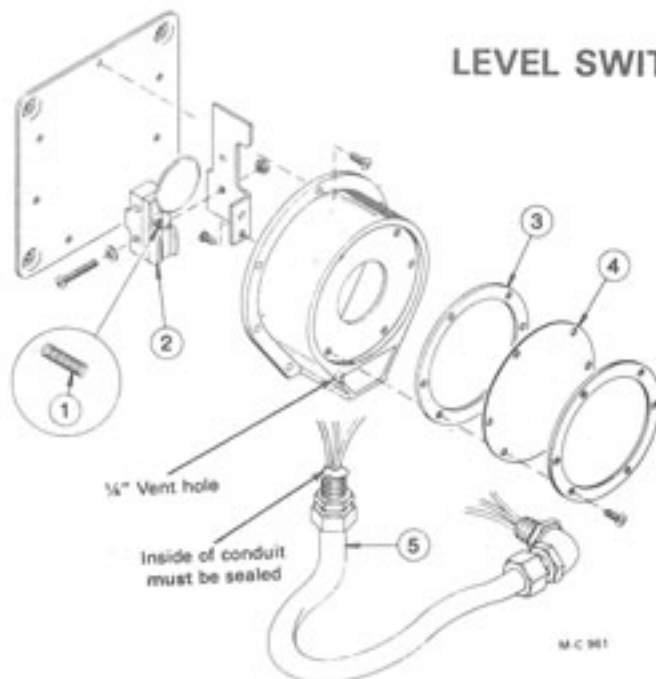

Ref.	Part No.	Qty.	Description
-	128 6992	1	Bin Level Indicator (Less Ref. 5)
1	122 6847	1	Spring
2	122 6848	1	Microswitch Ass'y
3	122 6850	1	Gasket
4	122 6849	1	Diaphragm (Teflon)
5	128 1995	1	Level Switch Wire Ass'y

DRYER MOTORS, CIRCUIT BREAKERS AND MAGNETIC STARTERS

MOTOR			CIRCUIT BREAKER			MAGNETIC STARTER			
HP	*FLA	Part No.	Part No.	Amps	Square "D" No.	Starter Part No.	Square "D" No.	Thermal Unit Part No.	Thermal Unit Size

200/208V - 3 PHASE - 60 HZ

□1.5	5.98	127 6833	128 6882	15	QOU 315	124 6931	DPS033	128 6947	B 9.10
†1.5	5.98	127 6861	128 6882	15	QOU 315	124 6931	DPS033	128 6947	B 9.10
2	7.82	127 6841	128 6882	15	QUO 315	124 6931	DPS033	128 6863	B 11.5
3	11.0	127 6832	124 6875	20	QOU 320	124 6931	DPS033	128 6823	B 17.5
5	17.5	127 6843	124 6876	35	QOU 335	124 6931	DPS033	120 6857	B 32
7.5	25.3	127 6858	124 6904	50	QOU 350	124 6930	DPS053	128 6979	B 40
10	32.2	203 6809	125 6912	60	QOU 360	124 6930	DPS053	128 6950	B 50
15	48.3	126 6854	128 6885	90	QOU 390	124 6930	DPS053	128 6953	B 79
20	62.1	127 6853	128 6966	100	QOU 3100	124 1082	DPA73	128 6827	CC 87.7
25	67.0	127 6852	128 6887	110	Q2L 3110	124 1082	DPA73	120 6844	CC 103
30	80.0	127 6859	124 6906	125	Q2L 3125	124 1083	DPA93	128 6954	CC 132

230V - 1 PHASE - 60 HZ

□1.5	8.3	121 6846	128 6878	20	QOU 220	124 6931	DPS033	128 6863	B 11.5
†1.5	10.6	127 6863	128 6878	20	QOU 220	124 6931	DPS033	120 6850	B 15.5
2	12.3	121 6862	124 6903	25	QOU 225	124 6931	DPS033	128 6949	B 19.5
3	20.0	128 6829	124 6909	40	QOU 240	124 6931	DPS033	120 6857	B 32
5	28.0	201 6815	128 6880	60	QOU 260	124 6930	DPS053	128 6979	B 40
†7.5	38.5	124 6816	124 6908	80	QOU 280	124 6930	DPS053	124 6910	B 66
†7.5	38.5	124 6888	124 6908	80	QOU 280	124 6930	DPS053	124 6910	B 66
10	45.0	124 6818	128 6881	90	QOU 290	124 6930	DPS053	128 6953	B 79
20	92.0	124 6879	124 6881	125	Q2L 2125	124 1083	DPA93	128 6820	CC 156

230V - 3 PHASE - 60 HZ

□1.5	5.0	121 6845	128 6882	15	QOU 315	124 6931	DPS033	120 6851	B 7.70
†1.5	5.0	127 6860	128 6882	15	QOU 315	124 6931	DPS033	120 6851	B 7.70
2	6.0	121 6861	128 6882	15	QOU 315	124 6931	DPS033	128 6947	B 9.10
3	9.0	128 6818	128 6882	15	QOU 315	124 6931	DPS033	125 6931	B 14.0
5	13.8	128 6815	124 6907	25	QOU 325	124 6931	DPS033	120 6855	B 25
7.5	20.6	121 6948	128 6968	40	QOU 340	124 6931	DPS033	128 6946	B 36
10	27.2	201 6818	125 6912	60	QOU 360	124 6930	DPS053	120 6853	B 45
15	39.2	201 6819	128 6891	80	QOU 380	124 6930	DPS053	128 6978	B 70
20	49.6	125 6934	128 6885	90	QOU 390	124 1082	DPA73	128 6972	CC 74.6
25	61.0	201 6842	128 6966	100	QOU 3100	124 1082	DPA73	128 6827	CC 87.7
30	73.0	128 6986	128 6887	110	QL2 3110	124 1083	DPA93	128 6820	CC 156

*If FLA (Full Load Amps) shown does not match FLA imprinted on motor name plate, refer to Square D charts for correct thermal unit size.

□ - 5/8" shaft

† - 3/4" shaft

† - 124 6816 has 1 1/8" shaft. 124 6888 has 1 1/4" shaft.

DRYER MOTORS, CIRCUIT BREAKERS AND MAGNETIC STARTERS

MOTOR			CIRCUIT BREAKER			MAGNETIC STARTER			
HP	*FLA	Part No.	Part No.	Amps	Square "D" No.	Starter Part No.	Square "D" No.	Thermal Unit Part No.	Thermal Unit Size

380V - 3 PHASE - 50 HZ

1.5	2.9	127 6860	128 6931	15	FAL 36015	124 6931	DPS033	128 6951	B 6.25
**1.5	2.9	123 6876	128 6931	15	FAL 36015	124 6931	DPS033	128 6951	B 6.25
2	3.7	121 6861	128 6931	15	FAL 36015	124 6931	DPS033	120 6845	B 6.90
**2	3.7	124 6867	128 6931	15	FAL 36015	124 6931	DPS033	120 6845	B 6.90
3	5.2	128 6818	128 6931	15	FAL 36015	124 6931	DPS033	128 6947	B 9.10
15	23.0	201 6819	128 6937	60	FAL 36060	124 6930	DPS053	120 6853	B 45
20	30.5	125 6842	124 6905	70	FAL 36070	124 6930	DPS053	128 6950	B 50
25	35.9	128 6986	125 6929	80	FAL 36080	124 6930	DPS053	128 6983	B 56

460V - 3 PHASE - 60 HZ

□1.5	2.5	121 6845	128 6931	15	FAL 36015	124 6931	DPS033	128 6984	B 3.00
†1.5	2.5	127 6860	128 6931	15	FAL 36015	124 6931	DPS033	128 6984	B 3.00
2	3.0	121 6861	128 6931	15	FAL 36015	124 6931	DPS033	128 6948	B 4.15
3	4.5	128 6818	128 6931	15	FAL 36015	124 6931	DPS033	120 6845	B 6.9
5	6.9	128 6815	128 6931	15	FAL 36015	124 6931	DPS033	128 6952	B 10.2
7.5	10.3	121 6948	128 6933	20	FAL 36020	124 6931	DPS033	128 6823	B 17.5
10	13.6	201 6818	125 6928	30	FAL 36030	124 6931	DPS033	120 6855	B 25.0
15	19.6	201 6819	128 6930	40	FAL 36040	124 6930	DPS053	128 6946	B 36
20	24.8	125 6934	128 6937	60	FAL 36060	124 6930	DPS053	120 6853	B 45
25	31	201 6842	124 6905	70	FAL 36070	124 6930	DPS053	128 6983	B 56
30	37	128 6986	125 6929	80	FAL 36080	124 6930	DPS053	128 6978	B 70

575V - 3 PHASE - 60 HZ

□1.5	2	127 6815	128 6931	15	FAL 36015	124 6931	DPS033	128 6984	B 3.00
†1.5	2	127 6862	128 6931	15	FAL 36015	124 6931	DPS033	128 6984	B 3.00
2	2.4	127 6816	128 6931	15	FAL 36015	124 6931	DPS033	120 6848	B 3.70
3	3.6	127 6814	128 6931	15	FAL 36015	124 6931	DPS033	120 6829	B 5.50
5	5.5	127 6847	128 6931	15	FAL 36015	124 6931	DPS033	128 6985	B 8.20
7.5	8.2	127 6828	128 6931	15	FAL 36015	124 6931	DPS033	128 6863	B 11.5
10	10.8	127 6857	128 6933	20	FAL 36020	124 6931	DPS033	128 6823	B 17.5
15	15.6	127 6845	125 6928	30	FAL 36030	124 6931	DPS033	128 6971	B 28
20	19.8	127 6844	128 6930	40	FAL 36040	124 6931	DPS033	128 6946	B 36
25	25	127 6846	128 6937	60	FAL 36060	124 6930	DPS053	120 6853	B 45
30	30	124 6902	128 6937	60	FAL 36060	124 6930	DPS053	128 6983	B 56

*If FLA (Full Load Amps) shown does not match FLA imprinted on motor name plate, refer to Square D charts for correct thermal unit size.

- ** - "C" Face
- - 5/8" shaft
- † - 7/8" shaft

115V COILS AND INTERLOCKS

STARTER		COIL		INTERLOCK	
SQUARE "D" NO.	M-C NO.	M-C NO.	SQUARE "D" NO.	M-C NO.	SQUARE "D" NO.
DPA73	124 1082	122 6861	9998-DA3V02	124 6933	9999-D-20
DPA93	124 1083	122 6861	9998-DA3V02	124 6933	9999-D-20
DPS053 (50) HZ	124 6930	122 6860	9998-DA1V02	124 6933	9999-D-20
DPS033 (50) HZ	124 6931	122 6860	9998-DA1V02	124 6933	9999-D-20
DPS033 (60) HZ	124 6931	122 6860	9998-DA1V02	124 6933	9999-D-20
DPS053 (60) HZ	124 6930	122 6860	9998-DA1V02	124 6933	9999-D-20

JUMPER STRAP KITS AND CONTACT KITS

STARTER		JUMPER STRAP KIT (2 STRAPS PER KIT)		CONTACT KIT	
SQUARE "D" NO.	M-C NO.	M-C NO.	SQUARE "D" NO.	M-C NO.	SQUARE "D" NO.
DPA73	124 1082	124 6885	9998-S032	122 6863	9998-DRC7
DPA93	124 1083	124 6885	9998-S032	122 6864	9998-DRC9
DPS033 (50) HZ	124 6931	120 6841	9998-S031		
DPS053 (50) HZ	124 6930	120 6841	9998-S031	122 6862	9998-DRC5
DPS033 (60) HZ	124 6931	120 6841	9998-S031		
DPS053 (60) HZ	124 6930	120 6841	9998-S031	122 6862	9998-DRC5

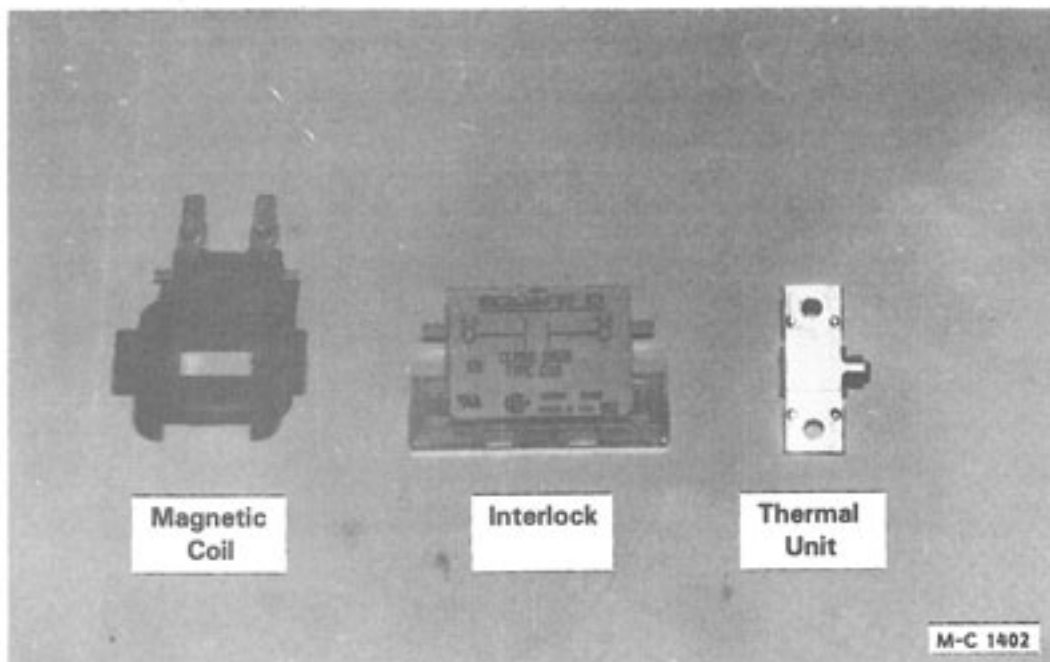

PORTABILITIES (Optional)

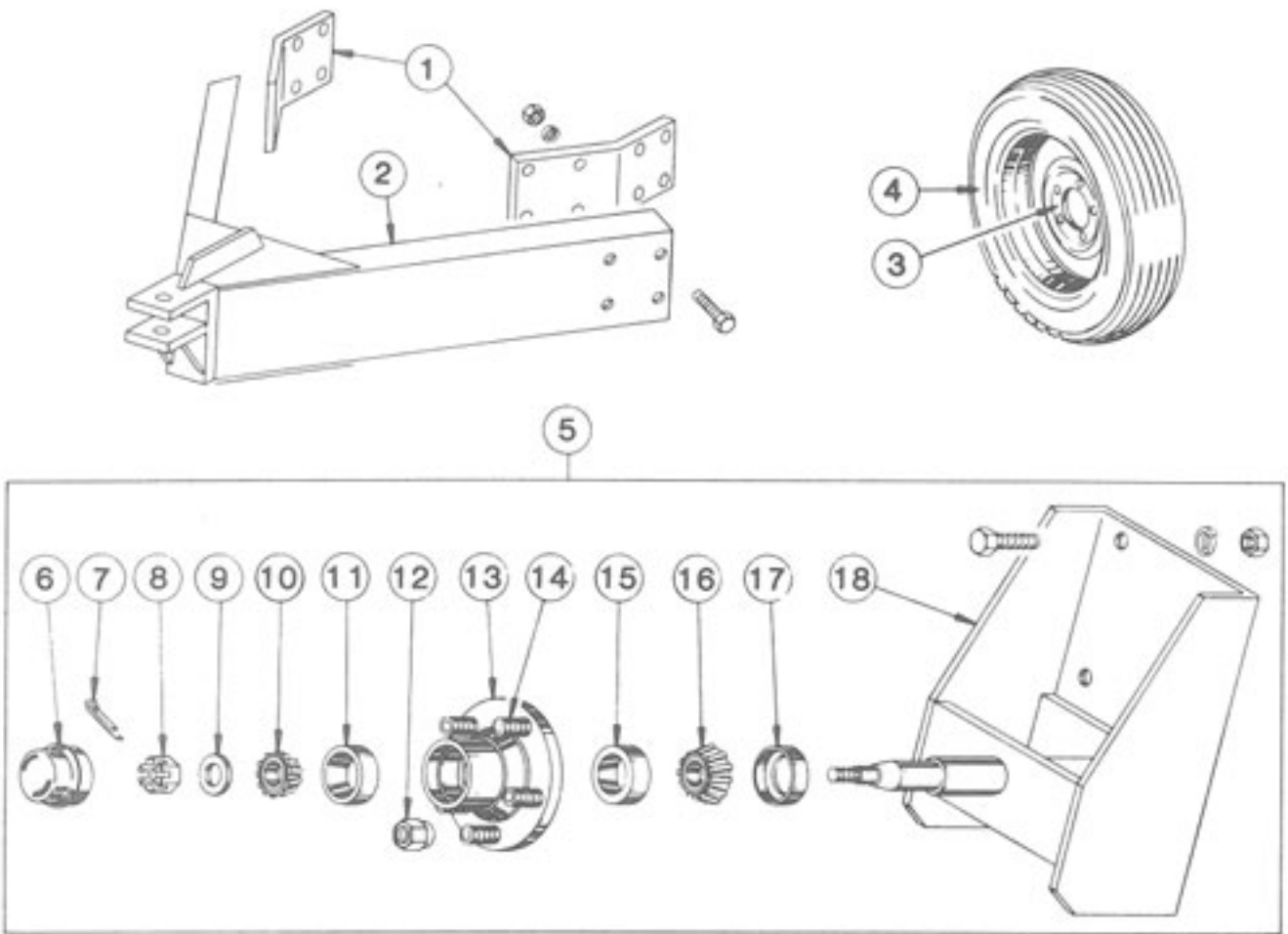

120 1030 - 4 Wheel Portabilities (Incl. Ref. 1 & 2 and four of Ref. 3 & 5 less tires)

M-C 980

Ref.	Part No.	Qty.	Description	Ref.	Part No.	Qty.	Description
1	128 3671	2	Pole Mount Brkt.	6	001 8996	1	Hub Cap
	128 8196	8	3/4-10 x 2 1/2" Capscrew - Grd.5	7	001 8252	1	Cotter Pin - 1/8" x 1"
	000 8182	8	3/4" Lockwasher	8	001 8253	1	Spindle Nut
	000 8165	8	3/4-10 Hex Nut	9	001 8254	1	Spindle Washer
2	120 0047	1	Dryer Pole	10	001 6000	1	Bearing Cone - Outer
	128 8195	8	3/4-10 x 2" Capscrew - Grd. 5	11	002 6000	1	Bearing Cup - Outer
	000 8182	8	3/4" Lockwasher	12	001 8989	5	1/2-20 Lug Nut - 45°
	000 8165	8	3/4-10 Hex Nut	13	001 8992	1	Wheel Hub Ass'y - 5 Bolt (Incl. Ref. 11, 14 & 15)
3	001 8993	1	5 Bolt Wheel - 15"	14	002 8152	5	1/2-20 x 1 1/2" Stud
4	127 8990	1	7.60 x 15-6 Ply Tubeless Tire	15	002 6001	1	Bearing Cup - Inner
5	120 1028	1	Wheel Spindle & Hub Ass'y (Incl. Ref. 6 thru 18)	16	001 6001	1	Bearing Cone - Inner
	000 8146	6	5/8-11 x 1 1/2" Capscrew - Grd.5	17	001 8991	1	Seal
	000 8181	6	5/8" Lockwasher	18	120 0031	1	Wheel Mount
	000 8164	6	5/8-11 Hex Nut				



Iron Horse Quality