

DISTRIBUTOR SPECIFICATIONS

4-Port

Top View

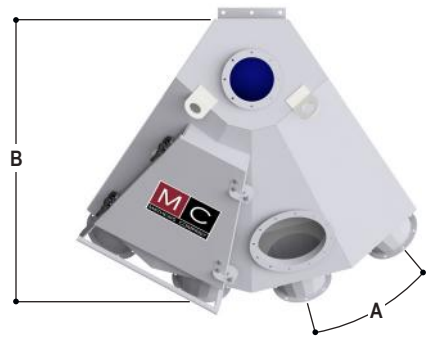

Front View

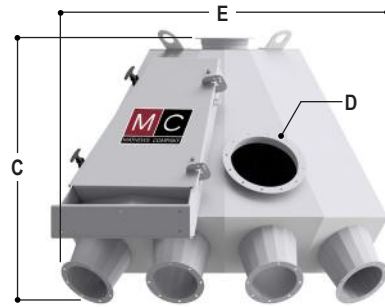

Dimensions

Size	6"	8"-10"	12"-14"	16"
A	28°			
B	44"	52"	62"	72"
C	38"	48"	58"	64"
D	10"	12"	12"	12"
E	49"	61"	71"	79"
Weight	243 lb	367 lb	531 lb	649 lb

6-Port

Top View

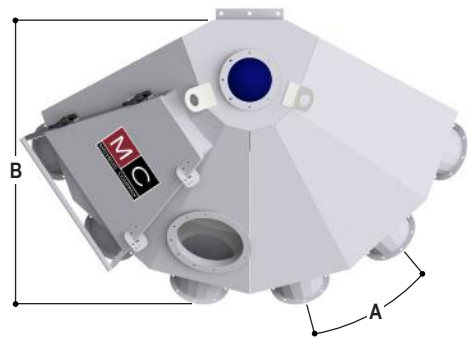

Front View

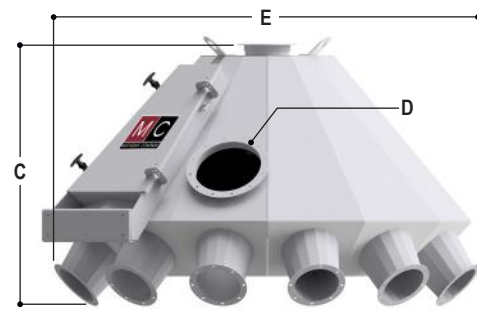

Dimensions

Size	6"	8"-10"	12"-14"	16"
A	28°			
B	44"	52"	62"	72"
C	38"	48"	58"	64"
D	10"	12"	12"	12"
E	61"	78"	94"	104"
Weight	279 lb	434 lb	640 lb	776 lb

8-Port

Top View

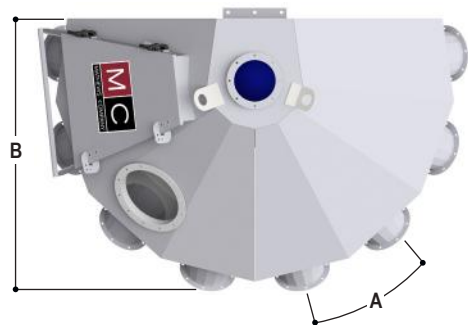

Front View

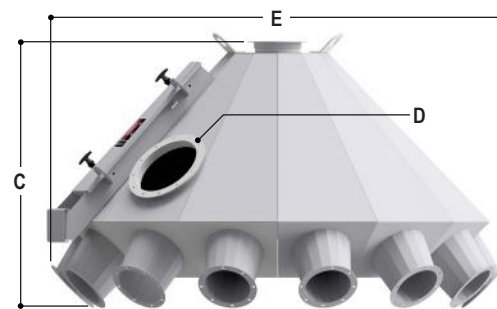

Dimensions

Size	6"	8"-10"	12"-14"	16"
A	28°			
B	44"	52"	62"	72"
C	38"	48"	58"	64"
D	10"	12"	12"	12"
E	61"	81"	97"	108"
Weight	304 lb	490 lb	715 lb	871 lb

At Mathews Company, we continuously strive to improve our products. Accordingly, changes may occur that are not reflected in the specifications and capacities contained in this brochure.

Your Authorized M-C Dealer is:



Mathews Company
www.MathewsCompany.com
 500 Industrial Ave
 Crystal Lake, IL 60012
 815-459-2210
mcsales@mathewscompany.com

BRO-MH01-0224



70 CELEBRATING
 YEARS
 1954 - 2024



SCAN ME TO
 LEARN MORE

Grain Site Specialists



MATERIAL HANDLING BUCKET ELEVATORS

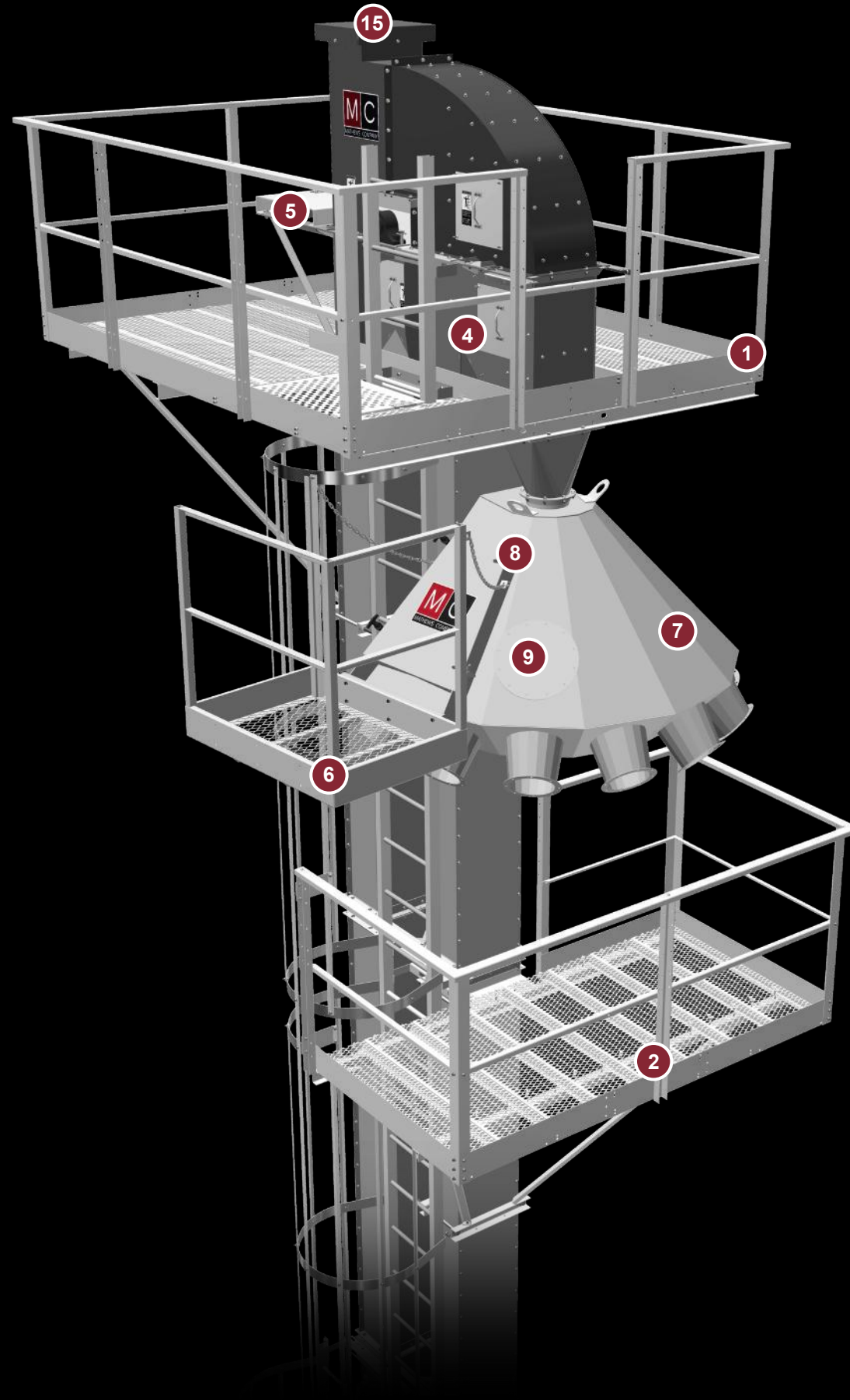

SPECIFICATIONS & FEATURES

Model Number	Pulley Diameter	Bucket Size	Bucket Spacing	Trunk Size	Discharge Capacity	Spout Size
18-75-075	18"	7" x 5"	7.5"	11" x 9"	1,300 bu/hr	6"
18-75-065			6.5"		1,600 bu/hr	
24-106-105	24"	10" x 6"	10.5"	14" x 10"	2,500 bu/hr	8"
24-106-085			8.5"		3,100 bu/hr	
24-106-075			7.5"		3,600 bu/hr	
30-117-100	30"	11" x 7"	10"	15" x 12"	4,900 bu/hr	10"
30-117-085			8.5"		5,700 bu/hr	
36-147-095	36"	14" x 7"	9.5"	18" x 12"	7,300 bu/hr	12"
36-147-085			8.5"		8,200 bu/hr	
42-148-095	42"	14" x 8"	9.5"	18" x 14"	10,400 bu/hr	14"
42-188-095			9.5"		22" x 14"	

- 1 **Head Service Platform** provides safe and easy access to head section, motor and drive components.
- 2 **Distributor Platform** provides access to optional distributor.
- 3 **Heavy-Duty Trunking** available in 14 ga or 11 ga galvanized steel with welded flanges.
- 4 **Solid Head Section** with fully welded construction and hot-dipped galvanized finish.
- 5 **Premium Drive** components utilizing Dodge TA-II gearbox reducers for heavy duty operation.
- 6 **Distributor Maintenance Platform** is optional and fully welded to provide easy access for distributor maintenance and cleanout.
- 7 **Solid Welded Construction** is standard on all M-C grain distributors to ensure many years of trouble-free operation.
- 8 **Large Access Door** provides for convenient reach to internal components of distributor for cleaning and servicing.
- 9 **Blower Mount** for installation of a blower to pressurize the distributor and control dust accumulation.
- 10 **Various Inlet Hoppers** available to accommodate site-specific requirements.
- 11 **Winged Boot Pulley** is an option for quieter operation while minimizing excess material build up behind belt.
- 12 **Inspection Sections** available in 5'-0" or 10'-0" height to provide access for maintenance.
- 13 **Trunking Alignment** specifically designed to stack true alleviating the need for shims and ensuring a trouble-free installation.
- 14 **Modular Ladder & Cage** arrangements available with rest platforms as needed to accommodate any site conditions for safe and easy access.
- 15 **Vented Head Section** to decrease hazards caused by excess grain dust accumulation.

The **MISSION** of Mathews Company is to design and build innovative, high-quality equipment by way of engineering excellence and world class manufacturing. Our goal is building relationships that last with our dealers, customers, and employees.

