



Model 375

(EM, EMS, B115 and B12)

Continuous Flow Grain Dryer



PARTS CATALOG

Form No. 260, January 1989

Mathews Company / 500 Industrial Ave., Crystal Lake, IL 60012, U.S.A.
815/459-2210 Telex: 72-2488

Revision No. 1

To

Model 375 Grain Dryer

PARTS CATALOG

Form No. D260, January 1989

Replace and add pages as instructed below

Replace Contents and Replace Pages

1 thru 8

23 thru 26 (Add 26A)

31 thru 38

Add Page

39

Mathews Company
P.O. Box 70, Crystal Lake, IL 60014

CONTENTS

Page

Introduction

Parts Ordering Instructions	1
Model and Serial Number Location	1
Capscrew Grade Identification	1

Parts

Air Pressure Switch	21
Auger (Unload)	2
Belts	
Fan Drive - 375 B12 and B115	18
Variable Speed Pulley	11, 12 & 13
Bin Level Indicator	33
Burner	15
Cabinets	
Control	27
Transformer	32
Coils	
Magnetic Starter - 115V	34
Solenoid Valve	36 & 37
Contacts for Magnetic Starters	34
Control Panel Lights and Switches	30
Electrical Components in Control Cabinet	28 & 29
Electrode	16
End Panels	6
Fan	17 & 18
Fan Drive	
Electric - 375 EM and EMS	17
PTO - 375 B12 and B115	18
Fan Housing	15
Fan Motor	34
Flame Sensing Probe	16
Floor Panels	6
Guards	20
High Limit Switch	21
Hopper	31
Ignition Board	28 & 29
Ignition Wires	16
Interlock - For Magnetic Starter	34
Jumper Straps for Magnetic Starters	34
Kits - Field Installed	39
Ladder - Rear	31
Level Switch Assembly	33
LP Gas Piping	22
Magnetic Starter - 375 EM and EMS	34
Manifolds	
LP Gas	25, 26 & 26A
Natural Gas	24

Continued on next page

Mercury Switch	2
Metering Rolls	2
Modulating Valves	24, 25 & 26
Modulating Valve Power Elements	24, 25 & 26
Modulating Valve Repair Kits	36 & 37
Moisture Control	21
Natural Gas Piping - Manifold to Burner	23
Peak	32
Portabilities	35
Pressure Gauge (Gas)	24, 25 & 26
Pressure Regulator (LP Gas)	24 & 25
Pressure Regulator (LP Gas) Repair Kit	36 & 37
PTO Shaft - 375 B12 and B115	19
Ratchet Unload System	
Belts - Variable Speed Pulley	11, 12 & 13
Complete System	8
Drive Reduction Base - Below S/N 39490	11
Drive Reduction Base - Above S/N 39489	12
Ratchet Arm Assemblies	10
Ratchet Stop Mount Plate Assembly	9
Solenoid	10
Variable Speed Pulley	14
Relay - 375 B12	29
Relief Valve - LP Gas	22
Roof - Optional	31
Screens	
Base Screens	4
Upper Screens	5
Shear Bolts - PTO Drive	18
Solenoid Valves	
1/2" - LP Gas	22
3/4" - LP Gas	24 & 25
1 1/4" - Natural Gas	26
Solenoid Valve Repair Kit	36 & 37
Tank Valve - LP Gas	22
Terminal Track	28 & 29
Thermometer - 6' Capillary	21
Timer - 10 Second Ignition	28
Transformer	32
Unload Auger	
Auger	2
Covers	2
Extension Kit (2 ft.)	38
Pans	3
Vaporizer Ring - LP Gas	15 & 22
Vaporizer to Manifold Pipe - LP Gas	22
Variable Speed Pulley	14
Variable Speed Pulley Belts	11, 12 & 13
Variable Speed Pulley Mount and Crank	13

INTRODUCTION

Parts Ordering Instructions

1. Order parts from your local M-C Dealer or distributor.
2. Always furnish the Grain Dryer model and serial number. This information is stamped on the serial number plate.
3. When ordering parts be sure to furnish the part number, description and quantity required.

NOTE: Attaching hardware is listed, but not included with, the main part. It must be ordered separately.

4. Inspect all shipments upon receipt. If any packages and/or boxes are missing, or parts are damaged, file a claim with the carrier immediately. Failure to do so may void a claim. Check the shipment against the packing list carefully. Report any shortages to the shipper immediately.

5. Do not return any parts to the Mathews Company without a "Return Goods Authorization" from the factory. All return parts shipments must be shipped prepaid (COD shipments will not be accepted). Shipments must also include the following:

- A. A letter of explanation including the "Return Goods Authorization Number," your name and address.
- B. A list of all parts being returned. List must include part numbers, description, quantity, and original invoice number.

Model and Serial Number Location

The model and serial number of your Grain Dryer are stamped on a plate located on the right base panel, see Figure 1. Record the model and serial number in the blank spaces in Figure 2.



Figure 1



Figure 2

Capscrew Grade Identification

There are four grades of hex-head capscrews. Grade 1 and 2 are common capscrews, grade 5 and 8 are used when greater strength is required. Each grade can be identified by the marking on the head of the capscrew, see chart below.

When replacing capscrews, be sure to use the correct size and grade. If a specific grade is not shown as part of the description, the capscrew is a grade 1 or 2.

CAPSCREW GRADE IDENTIFICATION CHART

S.A.E. Grade	Description	Capscrew Head Marking*
1	WILL HAVE A PLAIN HEAD - NO RADIAL LINES	
2	Low or Medium Carbon Steel Not Heat Treated	
5	WILL HAVE 3 RADIAL LINES Quenched and Tempered Medium Carbon Steel	
8	WILL HAVE 6 RADIAL LINES Quenched and Tempered Special Carbon or Alloy Steel	

*The center marking identifies the capscrew manufacturer.

Metering Rolls and Unload Auger

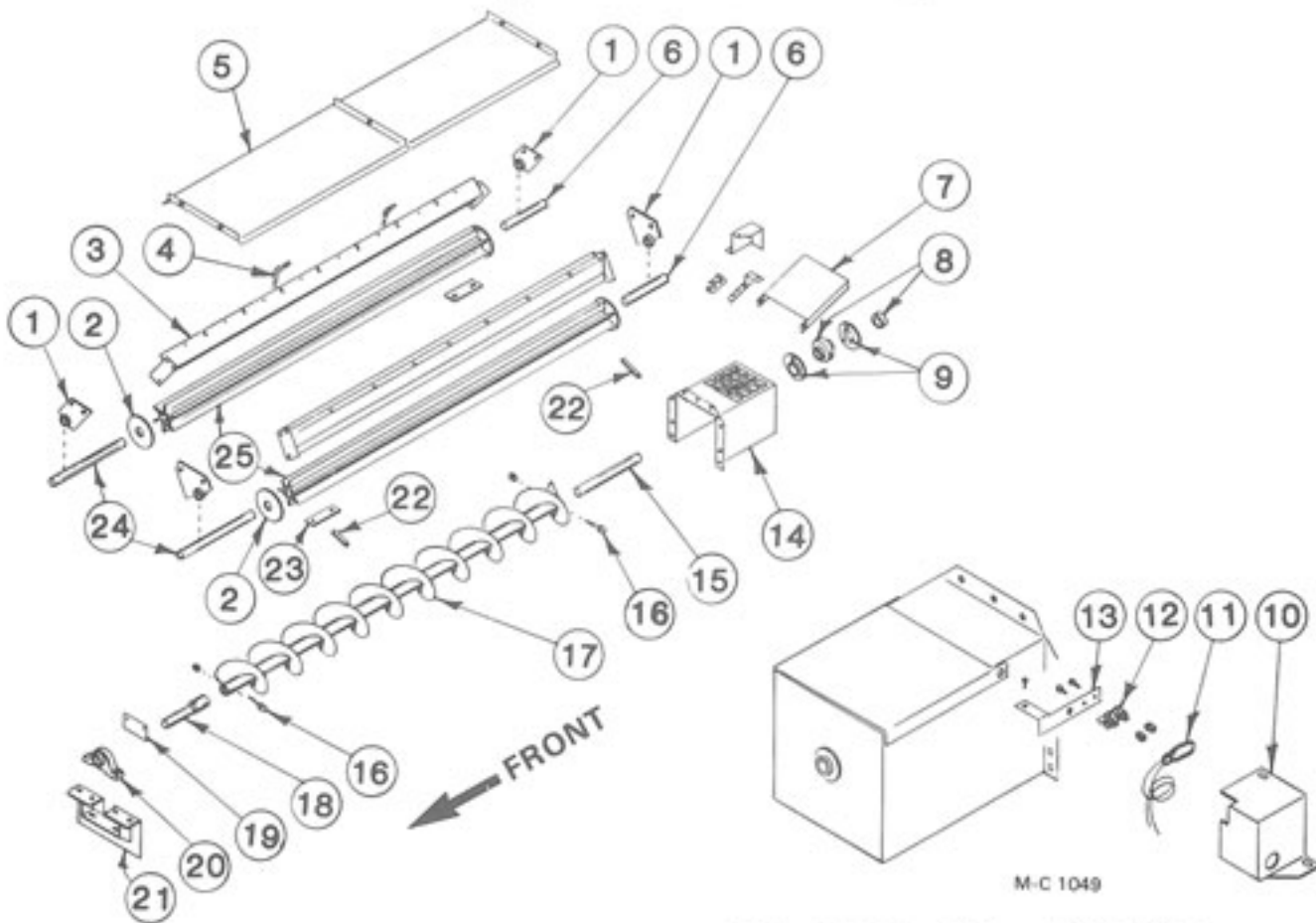

M-C 1049

Ref.	Part No.	Qty.	Description
1	128 1063	4	Metering Roll Brg. w/ Bronze Bushing
	000 8106	8	5/16 - 18 x 3/4" Capscrew
	000 8169	8	5/16 - 18 Flanged Locknut
2	121 4438	AR	Metering Roll Washer - 11 Gauge
	128 4970	AR	Metering Roll Washer - 16 Gauge
3	128 0225	2	Inner Perf. Mt. Weld
	000 8106	12	5/16 - 18 x 3/4" Capscrew
	000 8169	12	5/16 - 18 Flanged Locknut
4	128 8958	4	Support Rod (3/8" x 4 3/8")
	000 8173	4	5/16" Flatwasher
	000 8168	12	3/8 - 16 Flanged Locknut
5	128 2890	2	Unload Auger Cover
	001 8111	4	5/16 - 18 Clip Nut
	000 8106	5	5/16 - 18 x 3/4" Capscrew
	000 8173	5	5/16" Flatwasher
	000 8169	1	5/16 - 18 Flanged Locknut
6	121 5042	2	Metering Roll Stub Shaft (Rear) 1 1/4" x 5" (press fit in metering roll)
7	128 4712	1	Over Load Door
	000 8119	2	3/8 - 16 x 3/4" Capscrew
	000 8205	2	3/8 - 16 Top Lock Flanged Nut
8	001 6003	1	1 1/4" Bearing w/ Lock Collar
9	001 6004	2	1 1/4" Bearing Flangette
	000 8121	3	3/8 - 16 x 1" Capscrew
	000 8168	3	3/8 - 16 Flanged Locknut
10	128 4896	1	Shut-Off Switch Cover
	001 8284	2	5/16 - 12 x 1/2" Self- Tapping Screw
11	120 6800	1	Mercury Switch
12	120 6801	1	Mercury Switch Mt. Clip
	000 8282	2	6 - 32 x 1/4" Machine Screw
	000 8185	2	6 - 32 Flanged Locknut
13	128 2937	1	Bulb Mount
14	128 0096	1	Unload Auger Discharge Below S/N 47164
	128 0242	1	Unload Auger Discharge Above S/N 47163
	000 8106	9	5/16 - 18 x 3/4" Capscrew
	000 8169	9	5/16 - 18 Flanged Locknut

D260 Rev. 1, December 1990

Metering Rolls and Unload Auger

Ref.	Part No.	Qty.	Description	Ref.	Part No.	Qty.	Description
15	128 5998	1	Unload Auger Output Shaft	21	128 0075	1	Unload Auger Front Plate - Below S/N 47164
16	000 8229	4	3/8 - 16 x 2 3/4" Capscrew - Grd. 5		128 0247	1	Unload Auger Front Plate - Above S/N 47163
	000 8205	4	Top-Lock Flange Nut		000 8119	4	3/8 - 16 x 3/4" Capscrew
17	128 0079	1	Unload Auger (8") Below S/N 47164		000 8168	4	3/8 - 16 Flanged Locknut
	128 0276	1	Unload Auger (10") Above S/N 47163	22	000 8259	2	Roll Pin 5/16 x 1 3/4"
18	128 5996	1	Unload Auger Input Shaft	23	121 2637	2	Clean-Out Cover
19	128 3008	1	Front Seal Plate		000 8168	4	3/8 - 16 Flanged Locknut
	000 8184	4	8 - 18 x 1/2" Sheet Metal Screw	24	128 5042	2	Metering Roll Shaft (Front) 1 1/4" x 1 3/4" - (press fit in metering roll)
20	001 6011	1	1-7/16" Bore Pillow Block Brg.	25	128 1186	2	Metering Roll Ass'y. (incl. shafts)
	001 8299	2	1/2 - 13 x 1 3/4" Capscrew - Grd. 8 w/Nylock				
	001 8257	2	1/2" SAE Flatwasher				
	000 8163	2	1/2 - 13 Hex Nut				

Unload Auger Pan

Quick Clean Unload Auger Pan - Above S/N 47163

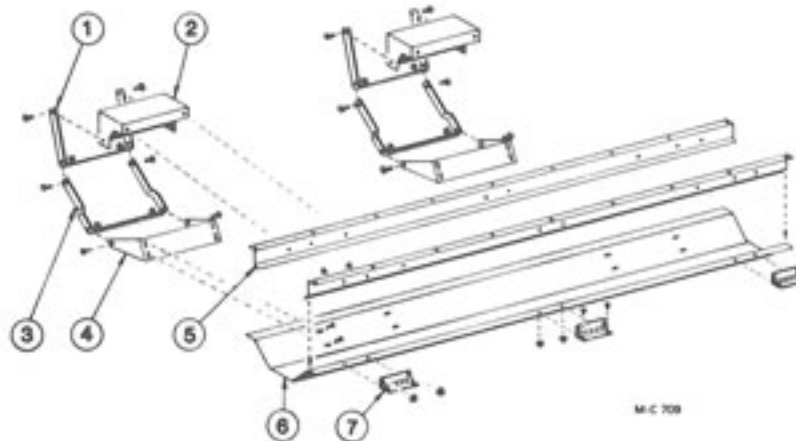

Unload Auger Pan - Below S/N 47164



Ref.	Part No.	Qty.	Description	Ref.	Part No.	Qty.	Description
1	128 2029	2	Auger Dump Arm Upper	6	128 2752	1	Auger Dump Pan
2	128 2750	2	Upper Link Pivot Base	7	128 8957	3	Hinge
3	128 2030	2	Auger Dump Arm Lower	7A	128 8355	2	Warning Decal (not shown)
4	128 2751	2	Bottom Link Pivot Base	8	128 2733	1	Unload Auger Pan
5	128 2673	2	Pan Hinge Angle				

Base Screens

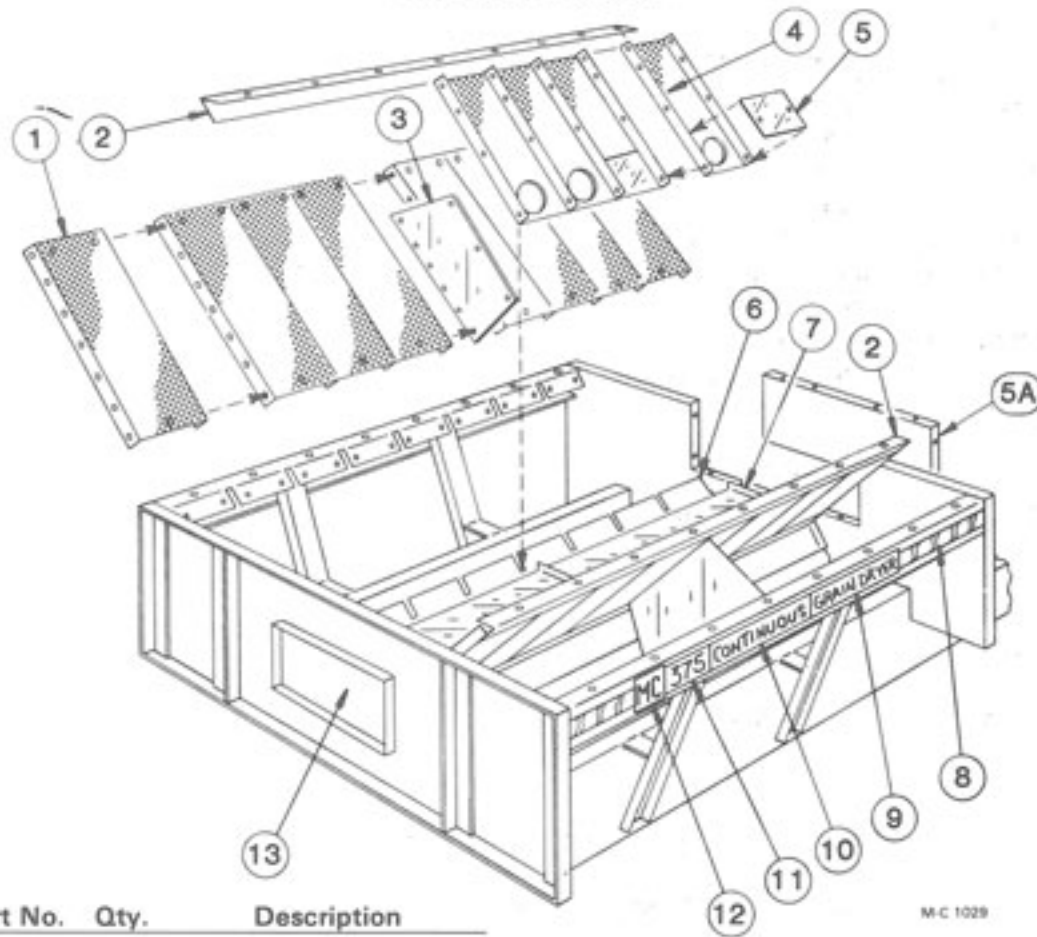

M-C 1029

Ref.	Part No.	Qty.	Description
1	---	---	Lower Outer Screen
	128 2951	16	Galvanized (Std.)
	127 2945	16	Small Seed (Galv.)
2	128 2739	2	Lower Screen Mt. Angle
3	128 2855	2	Lower Screen Stiffener
4	---	---	Lower Inner Screen
			w/Clean Out (See note 1)
	128 2994	16	Galvanized (Std.)
	127 2960	16	Small Seed (Galv.)
5	128 2995	16	Lower Inner Screen
			Cover
5A	128 4570	1	Base Filler Panel
			(37" x 13½")
	001 8135	12	⅜ - 16 x 1" Capscrew -
			Grd. 5
	000 8168	12	⅜-16 Flanged Locknut
6	128 0225	2	Inner Perf. Mt. Weld
	000 8106	12	5/16 - 18 x ¾" Capscrew
	000 8169	12	5/16 - 18 Flanged
			Locknut

Ref.	Part No.	Qty.	Description
7	128 2890	2	Unload Auger Cover
	001 8111	4	5/16 - 18 Clip Nut
	000 8106	5	5/16 - 18 x ¾" Capscrew
	000 8173	5	5/16" Flatwasher
	000 8169	1	5/16 - 18 Flanged
			Locknut
8	128 8310	7 ft.	Red & Yellow Stripe
			Decal - 2½"
9	128 8309	2	"Grain Dryer" Decal
10	128 8308	2	"Continuous" Decal
11	128 8307	2	"375" Decal
12	128 8300	2	M-C Decal -
			5" x 4-9/16"
13	128 2894	2	Base Panel Access Door -
			17½" x 10½" (See note 2)
	001 8284	14	5/16 - 12 x ½" Self
			Tapping Screw

NOTE 1: Screen w/o clean-out is no longer available. Order Galvanized (Std.) Screen Ass'y. 124 1032 or Small Seed (Galv.) Screen Ass'y. 124 1033. Assemblies include ref. 4 screen, ref. 5 cover and cover attaching hardware.

NOTE 2: Starting in 1989, the dryer front panel was changed. Base Filler Panel (ref. 5A) is now used at the front of the dryer in place of the Base Panel Access Door 128 2894.

Upper Screens

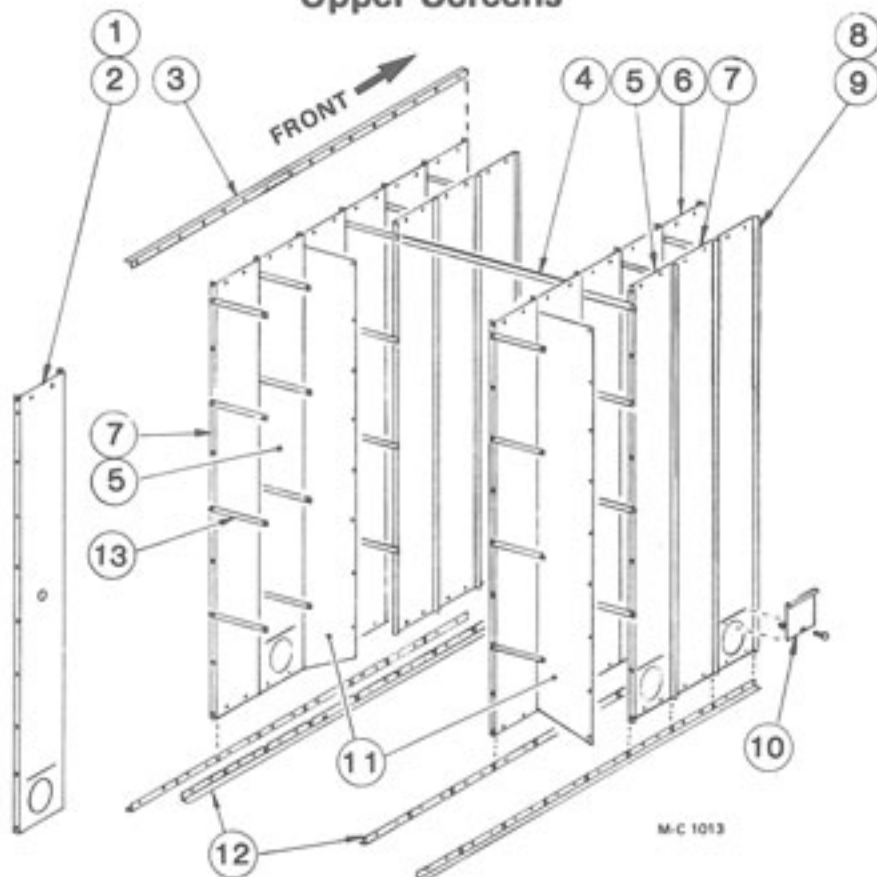

Ref.	Part No.	Qty.	Description	Ref.	Part No.	Qty.	Description
1	---	---	Moisture Control Screen	7	---	---	Outer Screen w/o Quick Drain Hole
	128 2971	2	Galvanized (Std.)		128 2945	4	Galvanized (Std.)
	127 2955	2	Small Seed (Galv.)		127 2948	4	Small Seed (Galv.)
	123 5209	2	Aluminum		123 2955	4	Aluminum
2	---	---	Moisture Control Screen w/Quick Drain Hole (See note 1)	8	---	---	Outer End Screen w/o Quick Drain Hole
	127 2989	2	Galvanized (Std.)		128 2965	2	Galvanized (Std.)
	127 2988	2	Small Seed (Galv.)		127 2952	2	Small Seed (Galv.)
3	128 2380	2	Side Joiner Angle		123 5208	2	Aluminum
4	128 2014	1	Inner Screen Cross Tie	98	---	---	Outer End Screen w/Quick Drain Hole
5	---	---	Outer Screen w/Quick Drain Hole (See note 2)		128 3000	2	Galvanized (Std.)
	127 2949	6	Galvanized (Std.)		127 2961	2	Small Seed (Galv.)
	127 2962	6	Small Seed (Galv.)		123 2348	2	Aluminum
	123 2349	6	Aluminum	10	---	---	Quick Drain Door
6	---	---	Inner Screen		127 2950	8	Galvanized (Std.)
	128 2974	16	Galvanized (Std.)		127 2974	8	Small Seed (Galv.)
	127 2954	16	Small Seed (Galv.)		001 8269	8	3/8 - 16 x 3/4" Carriage Bolt
					000 8168	8	3/8 - 16 Flanged Locknut
				11	128 2871	2	Divider Panel
				12	125 2732	4	Screen Mount Angle
				13	121 3007	48	Column Stiffener Strap

NOTE 1: Used on dryers with quick drain in every column.

NOTE 2: Outer Screen 127 2949 with quick drain door 127 2950 installed is available. Order 127 1010.

End Panels and Floor Panels

Rear Door Detail

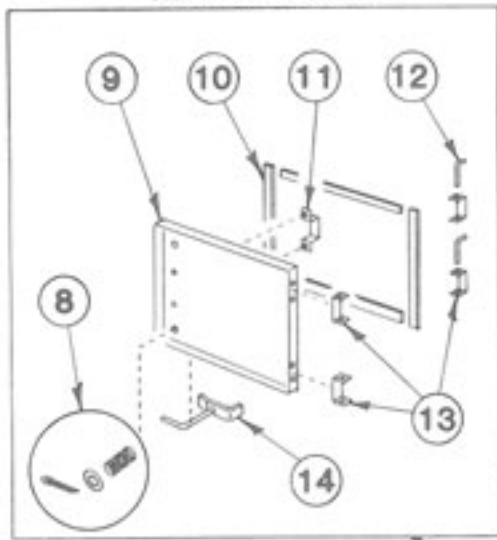

Heat Chamber Door Detail

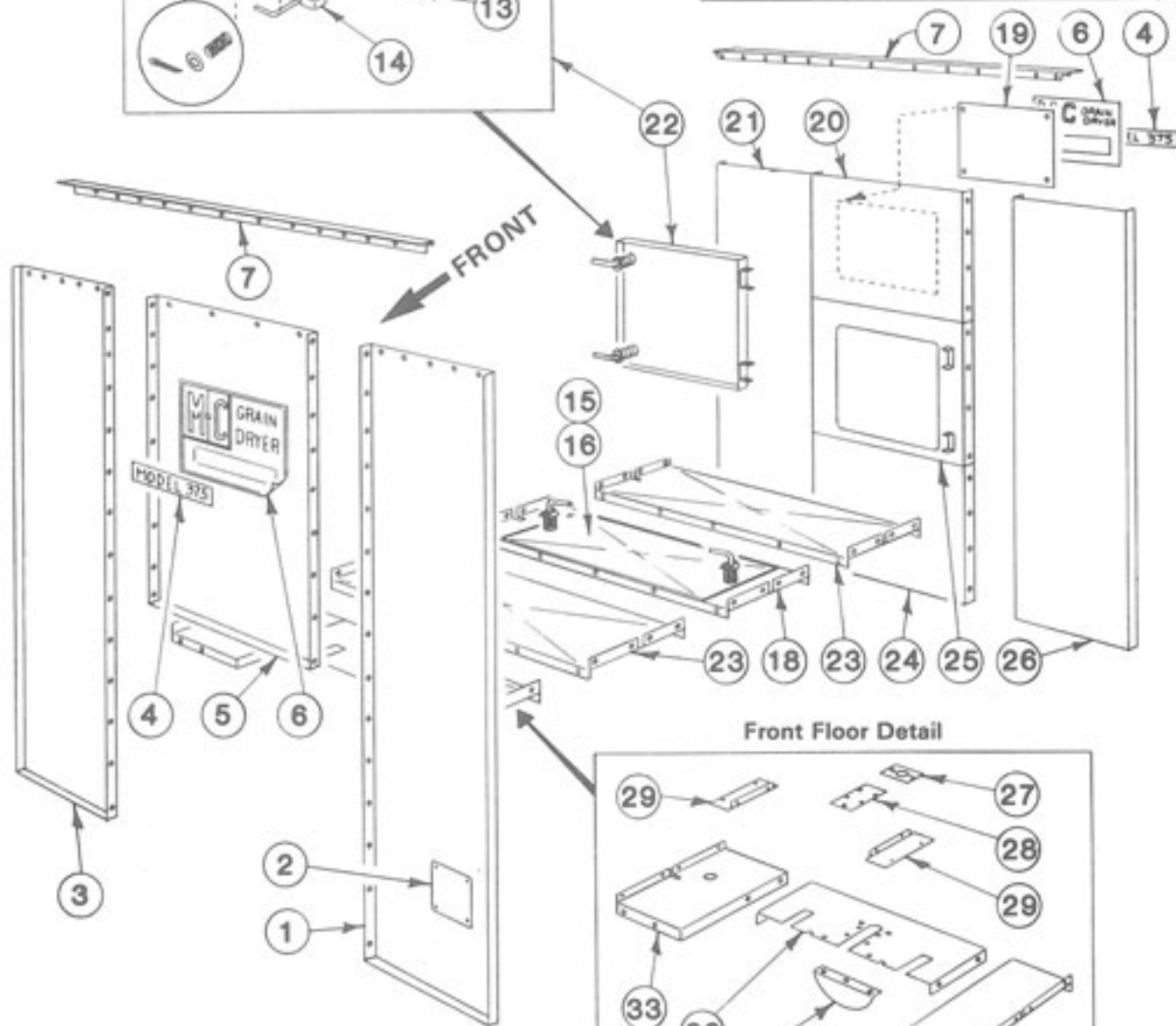
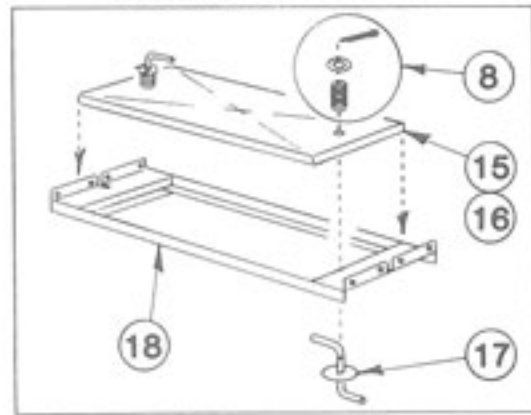

Front Floor Detail

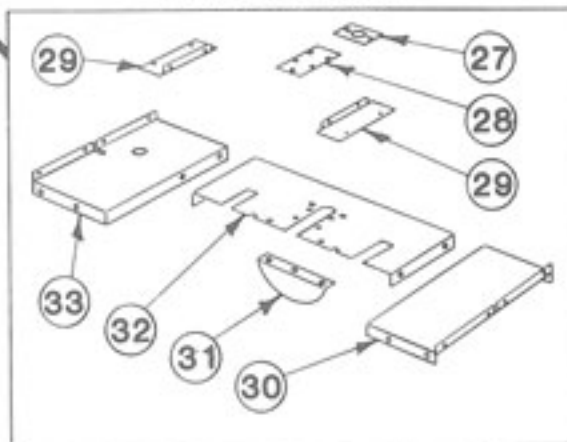

M-C 1050

End Panels and Floor Panels

Ref.	Part No.	Qty.	Description	Ref.	Part No.	Qty.	Description
1	128 2831	1	Front End Panel - Left	15	121 1113	1	Heat Chamber Door Ass'y. (Incl. ref. 8, 16 & 17)
2	127 8300	1	"CGA" Dryer Plate (Canada only)	16	121 2970	1	Heat Chamber Door Panel
3	128 2833	1	Front End Panel - Right	17	121 0302	2	Latch and Handle
4	128 8323	2	Model 375 Decal (Use w/ref. 6)	18	121 0299	1	Heat Chamber Door Frame
5	128 2839	1	Panel Above Fan	19	128 2999	1	Decal Mt. Plate
6	128 8331	2	Large Decal - See note		000 8238	4	5/16 - 18 x 1/2" Capscrew
7	128 2650	2	End Panel Joiner Angle	20	128 2876	1	Panel Above Door
8	001 8256	4	Spring - 3/8" ID x 2"	21	128 2867	1	Rear End Panel - Right
	000 8174	8	3/8" Flatwasher	22	128 1183	1	Rear Door Ass'y. (Incl. ref. 8 thru 14)
	000 8199	4	1/8" x 1" Cotter Pin	23	121 2928	2	Unit Floor Panel
9	128 2957	1	Rear Door Panel	24	128 2888	1	Panel Below Door
10	121 8966	10 ft.	Weather Stripping	25	128 2715	1	Door Frame
11	121 2887	1	Door Handle	26	128 2866	1	Rear End Panel - Left
	128 8251	2	8 - 18 x 1/2" Sheet Metal Screw	27	121 4818	1	Seal Plate - 3/4" Hole (LP Gas)
12	128 5201	2	Hinge Pin		123 2834	1	Seal Plate - 1 1/4" Hole (Natural Gas)
13	128 2740	4	Door Hinge	28	128 2835	1	Floor Panel Slot Cover
	000 8212	8	1/4 - 20 x 1/2" Truss Hd. Screw	29	121 2980	2	Orifice Seal Plate
	000 8167	8	1/4 - 20 Flanged Locknut	30	125 2870	1	Front Floor Panel - Left
14	121 0414	1	Latch and Handle	31	128 2880	1	Burner Tube Baffle
				32	128 2881	1	Front Floor Panel - Center
				33	125 2871	1	Front Floor Panel - Right

NOTE: This decal is imprinted "Model 975." Order one of ref. 4 to be placed over "Model 975."

Ratchet Unload System

NOTE: Starting in 1989, the dryer base front panel was changed. Base Filler Panel 128 4570 (37" x 13 1/2") is now used at the front of the dryer in place of the Base Panel Access Door 128 2894.

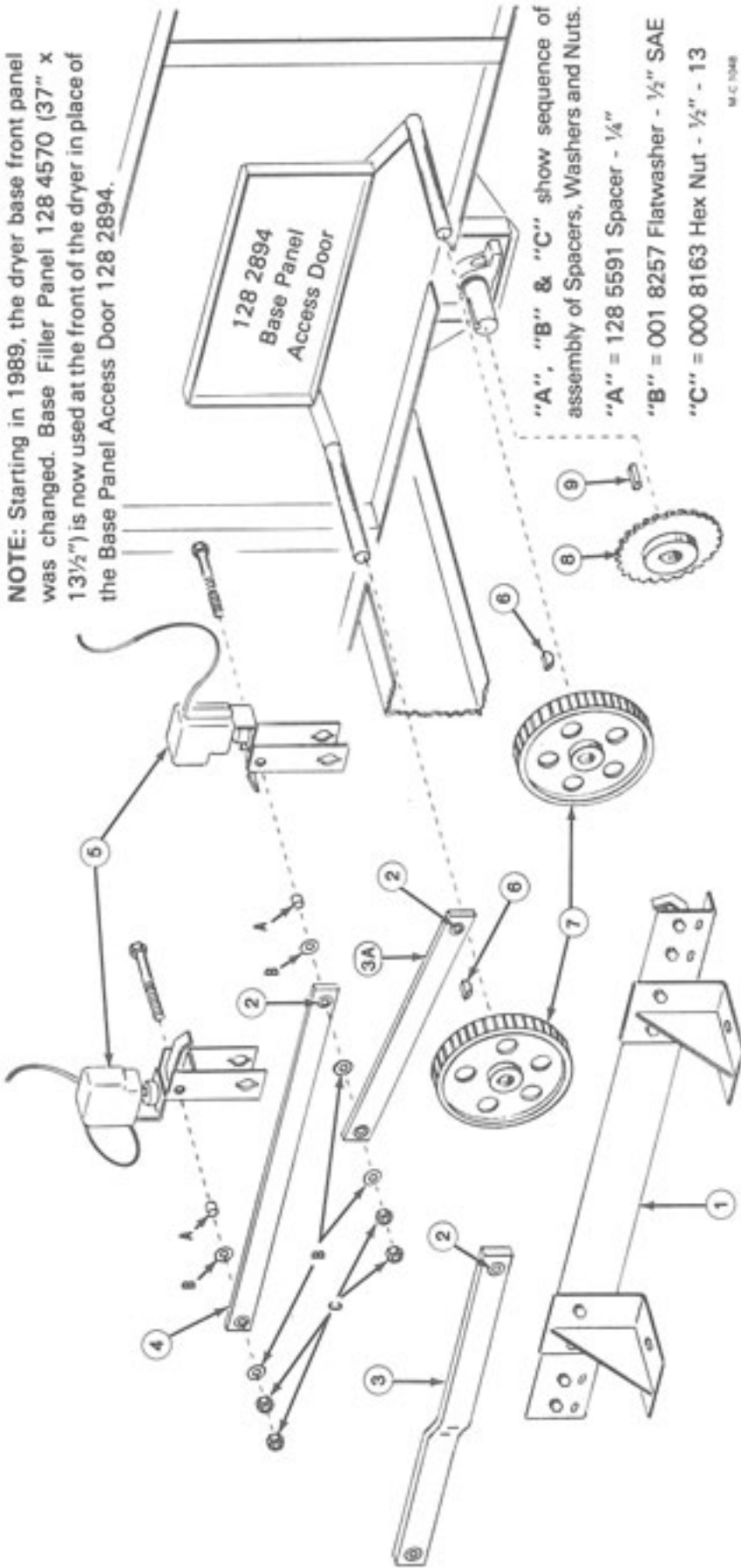

"A", "B" & "C" show sequence of assembly of Spacers, Washers and Nuts.
 "A" = 128 5591 Spacer - 1/4"
 "B" = 001 8257 Flatwasher - 1/2" SAE
 "C" = 000 8163 Hex Nut - 1/2" - 13

M.C. 1048

Ref.	Part No.	Qty.	Description
1	---	1	Ratchet Stop Mt. Plate Ass'y. (See page 9)
2	121 6001	4	Bearing - 1 1/4" OD x 1/2" Bore
3	128 1411	1	Transfer Arm w/Two Brgs. (Early production)
3A	128 1029	1	Transfer Arm w/Two Brgs.-24 1/4" (Late production)
	001 8164	1	1/2 - 13 x 2" Carriage Bolt
	000 8299	1	5/8" SAE Flatwasher
	001 8257	2	1/2" SAE Flatwasher

Ref.	Part No.	Qty.	Description
	000 8175	1	1/2" Flatwasher
	000 8170	1	1/2 - 13 Flanged Locknut
4	128 1261	1	Connecting Arm w/Two Brgs. - 22"
5	---	1	Ratchet Arm Ass'y. (See page 10)
6	000 8298	2	Woodruff Key - 1/4" x 3/8"
7	121 6404	2	Ratchet Wheel
8	128 6418	1	Sprocket-RC-40-B (45 Teeth)
9	001 5130	1	Square Key - 3/8" x 1"

Ratchet Stop Mount Plate Assembly

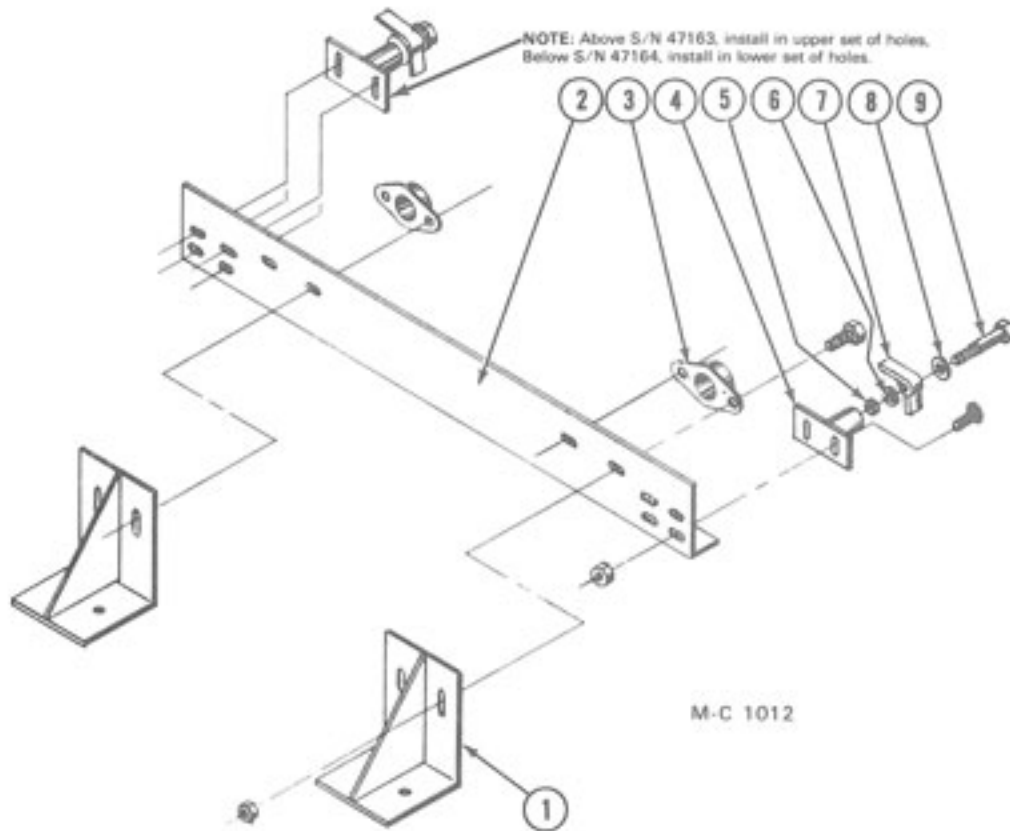

Ref.	Part No.	Qty.	Description
1	128 0191	2	Outboard Bearing Mt.
	000 8121	4	$\frac{3}{8}$ - 16 x 1" Hex - Hd. Capscrew
	000 8174	4	$\frac{3}{8}$ " Flatwasher
	000 8168	4	$\frac{3}{8}$ - 16 Flanged Locknut
2	128 2652	1	Ratchet Stop Dog Mt. Plate
3	121 6022	2	Outboard Bearing - 1 $\frac{1}{4}$ "
	000 8121	4	$\frac{3}{8}$ - 16 x 1" Hex - Hd. Capscrew
	000 8174	4	$\frac{3}{8}$ " Flatwasher
	000 8168	4	$\frac{3}{8}$ - 16 Flanged Locknut
4	121 0355	2	Ratchet Stop Mt.
	000 8104	4	$\frac{5}{16}$ - 18 x $\frac{3}{4}$ " Truss Hd. Screw
	000 8169	4	$\frac{5}{16}$ - 18 Flanged Locknut
5	001 8139	2	$\frac{3}{8}$ " Lockwasher
6	000 8173	2	$\frac{5}{16}$ " Flatwasher
7	121 0354	2	Ratchet Stop Dog
8	001 8257	2	$\frac{1}{2}$ " SAE Flatwasher
9	121 8162	2	$\frac{3}{8}$ - 16 x 1 $\frac{1}{2}$ " Hex - Hd. 1" Shoulder Bolt

Ratchet Arm Assembly

(Quantities shown are for one assembly)

Ref.	Part No.	Qty.	Description
1	121 6856	1	Solenoid - 115V
	125 6883	1	Solenoid - 12V (DC)
2	000 8249	1	Cotter Pin - 1/8" x 3/4"
3	121 0029	1	Solenoid Weight
4	121 0030	1	Ratchet Dog
5	121 0036	1	Ratchet Guide Arm (Late production)
6	000 8163	2	1/2 - 13 Hex Nut
7	001 8257	2	1/2" SAE Flatwasher (3 on right side)
8	128 5591	1	1/4" Spacer
9	001 8298	1	1/4 - 20 x 1 3/4" Hex - Hd. Capscrew
10	000 8167	1	1/4 - 20 Locknut
11	000 8144	1	1/2 - 13 x 3 1/2" Hex - Hd. Capscrew - Grd. 5 (Left side)
	001 8168	1	1/2 - 13 x 4 1/2" Hex - Hd. Capscrew - Grd. 5 (Right side)
12	000 8186	2	6 - 32 x 1/2" Machine Screw
13	000 8185	2	6 - 32 Flanged Locknut
14	121 6859	1	Jiffy Clip
15	124 6820	1	Solenoid Boot
16	128 1095	1	Ratchet Cord - Left (50")
	128 1088	1	Ratchet Cord - Right (29")
17	128 6011	2	Nylon Bushing (Early production)
18	128 0223	1	Ratchet Arm Guide (Early production)

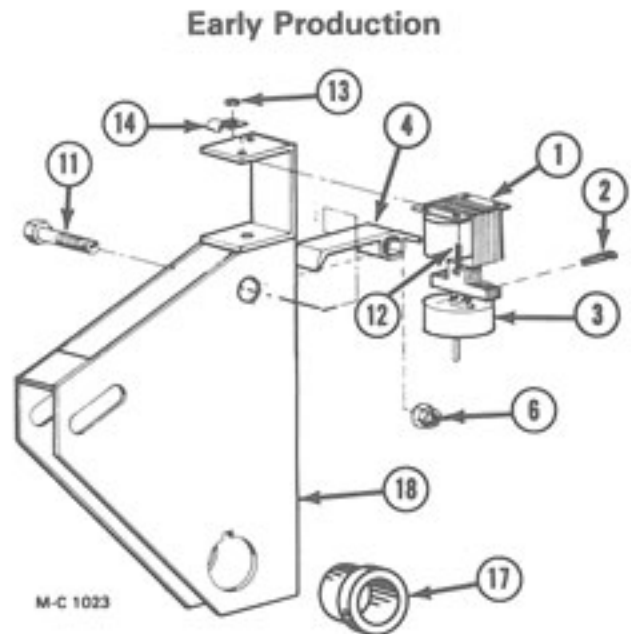
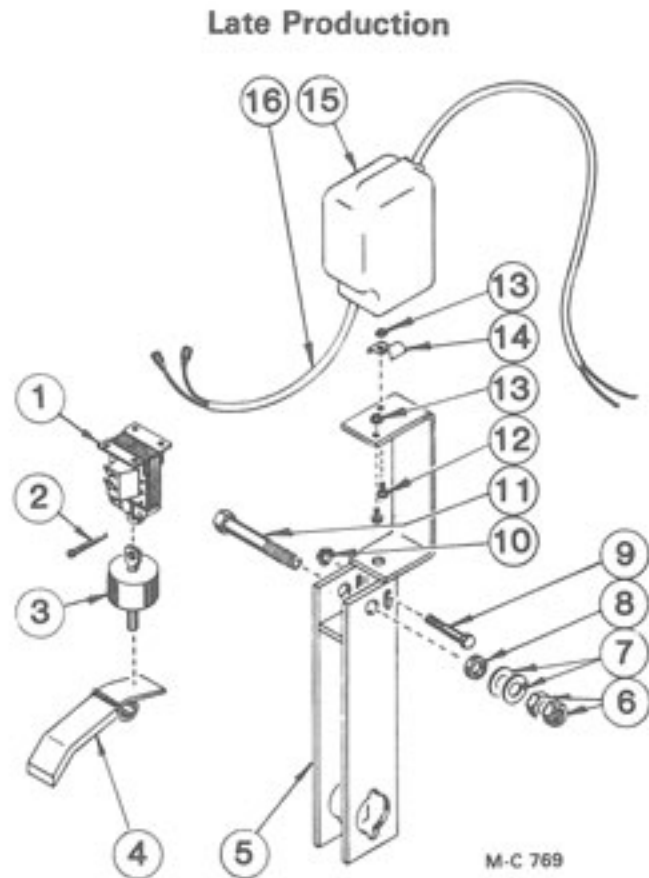

Drive Reduction Base (Below S/N 39490)

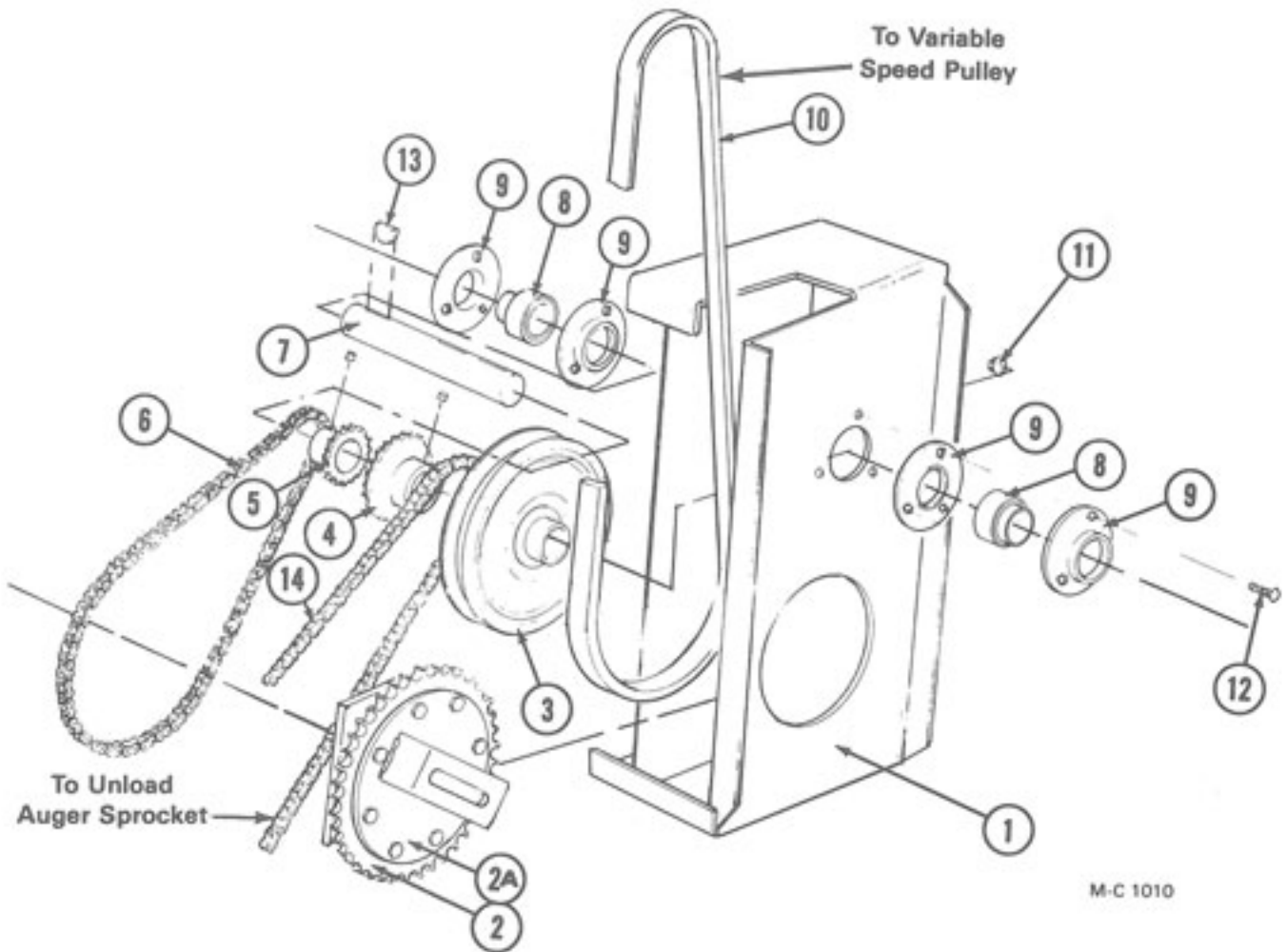

M-C 1010

Ref.	Part No.	Qty.	Description	Ref.	Part No.	Qty.	Description
1	128 0155	1	Jackshaft Bracket	8	001 6008	2	1" Bearing w/Collar
2	128 1236	1	Eccentric Sprocket w/Mt. & Brgs.	9	001 6014	4	1" 3 Bolt Brg. Stamping
2A	128 0103	1	Eccentric Slide Brkt.	10	001 6100	1	BX56 V-Belt
	000 8106	8	5/16 x 18 x 3/4" Capscrew	11	000 8168	6	3/8 - 16 Flanged Locknut
	000 8173	8	5/16" Flatwasher	12	000 8122	6	3/8 - 16 x 1" Carriage Bolt - Grd. 5
	000 8169	8	5/16 - 18 Locknut	13	000 8298	3	1/4" x 3/4" Woodruff Key
3	128 6213	1	Pulley - 12" OD x 1" Bore	14	128 6306	1	RC-40 x 194 Pitch Chain
4	128 6419	1	Sprocket (RC-40B x 18T x 1" Bore)	Not Shown			
5	128 6416	1	Sprocket (RC-35 x 16T x 1" Bore)	—	128 0224	1	Idler Mount Brkt.
6	128 6305	1	RC-35 x 112 Pitch Chain	—	128 4492	1	Idler Take-Up Brkt.
7	128 5023	1	Jackshaft	—	128 6414	2	Idler Sprocket RC-40 x 18T x 1/2" Bore

Drive Reduction Base

(Above S/N 39489)

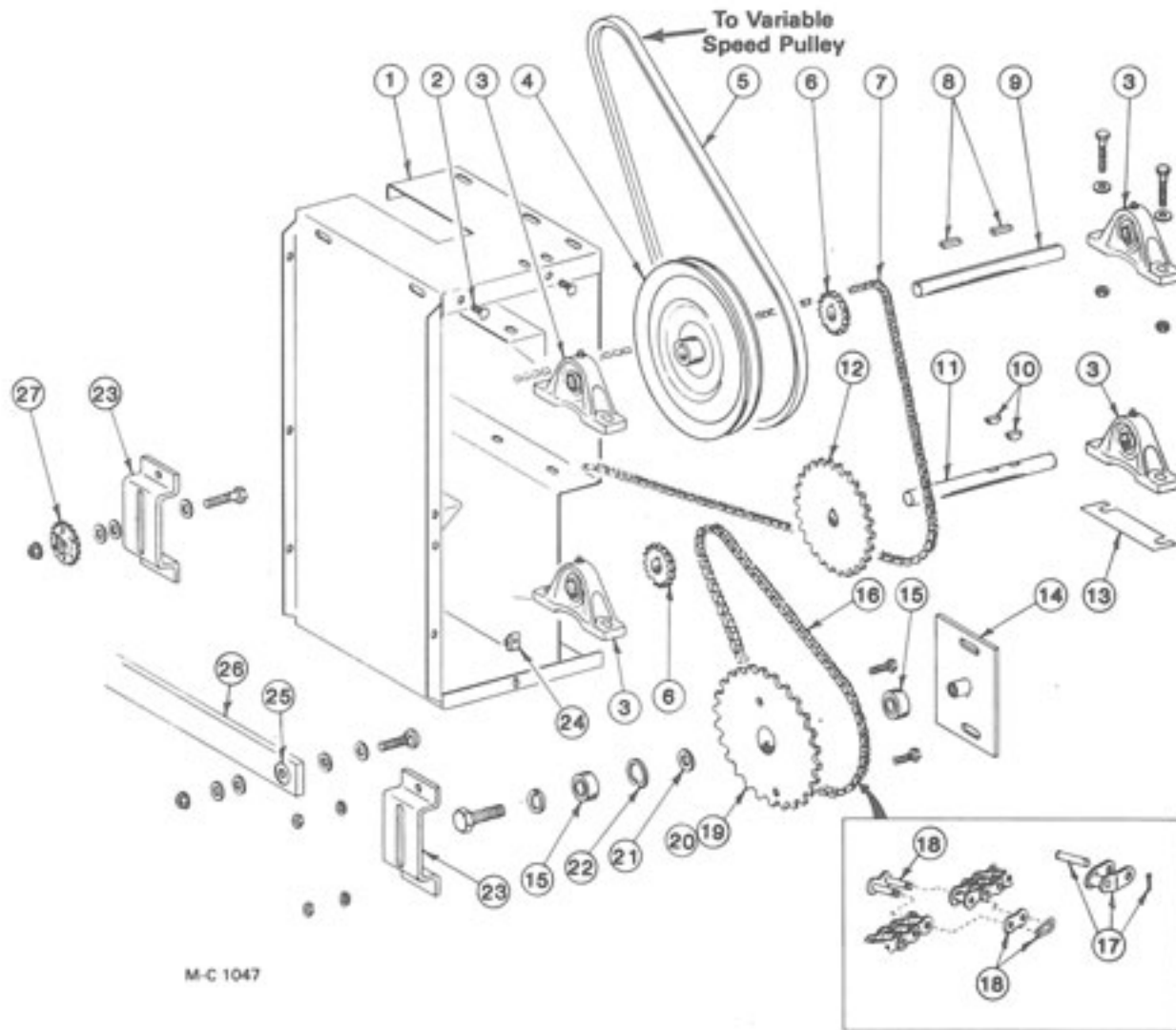

M-C 1047

Ref.	Part No.	Qty.	Description
1	128 0239	1	Reduction Base Weld
2	000 8122	2	3/8 - 16 x 1" Carriage Bolts - Grd. 5
	000 8168	2	3/8 - 16 Flanged Locknut
3	127 6000	4	Pillow Block Brg. w/ Zerk - 1" Bore
	000 8123	8	3/8 - 16 x 1 1/4" Capscrew
	000 8168	8	3/8 - 16 Flanged Locknut
4	128 6213	1	Pulley - 12" OD x 1" Bore
5	128 6121	1	BX54 Belt
6	121 6405	2	Sprocket (RC-40B x 16T x 1" Bore)
7	128 6313	1	RC - 40 x 210 Pitch Unloading Auger Drive Chain
8	001 5118	2	1/4" x 1 1/4" Key
9	128 5026	1	Upper Jackshaft
10	000 8298	2	1/4" x 3/4" Woodruff Key
11	128 5027	1	Lower Jackshaft

Ref.	Part No.	Qty.	Description
12	128 6421	1	Sprocket (RC-40B x 48T x 1" Bore)
13	128 2896	AR	Shim - 16 Gauge
	128 3070	AR	Shim - 20 Gauge
14	128 0187	1	Eccentric Sprocket Mtg. Plate
	000 8136	2	1/2 - 13 x 1" Carriage Bolt
	000 8170	2	1/2 - 13 Flanged Locknut
15	001 6006	2	Double Seal Brg. - 3/4"
16	128 6309	1	RC-40 x 74 Pitch Primary Reduction Chain
17	122 6305	—	RC-40 Off-Set Link
18	002 6309	—	RC-40 Connecting Link
19	--- ---	1	Sprocket (NA - order ref. 20)
20	128 1026	1	Eccentric Sprocket Ass'y. (Incl. ref. 15, 19, 21 & 22)

Continued on next page

Drive Reduction Base (Above S/N 39489)

Ref.	Part No.	Qty.	Description	Ref.	Part No.	Qty.	Description
	128 8196	1	3/4 - 10 x 2 1/2" Capscrew - Grd. 5	26	128 1411	1	Transfer Arm w/Two Brgs. (ref. 25)
	000 8182	1	3/4" Lockwasher	001 8164	1	1/2 - 13 x 2" Carriage Bolt	
21	128 8253	1	Washer	000 8299	1	3/8" SAE Flatwasher	
22	128 8101	1	Snap Ring	001 8257	2	1/2" SAE Flatwasher	
23	128 3414	2	Sprocket Slide	000 8175	1	1/2" Std. Flatwasher	
	000 8121	4	3/8 - 16 x 1" Capscrew	000 8170	1	1/2 - 13 Flanged Locknut	
	000 8179	2	3/8" Lockwasher	27	128 6414	1	Idler Sprocket (RC-40 x 18T x 1/2" bore)
	000 8162	2	3/8 - 16 Hex Nut	000 8140	1	1/2 - 13 x 2" Capscrew - Grd. 5	
	000 8168	2	3/8 - 16 Flanged Locknut	001 8257	3	1/2" SAE Flatwasher	
24	001 8111	1	5/16 - 18 Clip Nut	000 8170	1	1/2 - 13 Flanged Locknut	
25	121 6001	2	Bearing - 1 1/4" OD x 1/2" Bore				

Variable Speed Pulley Mount and Crank

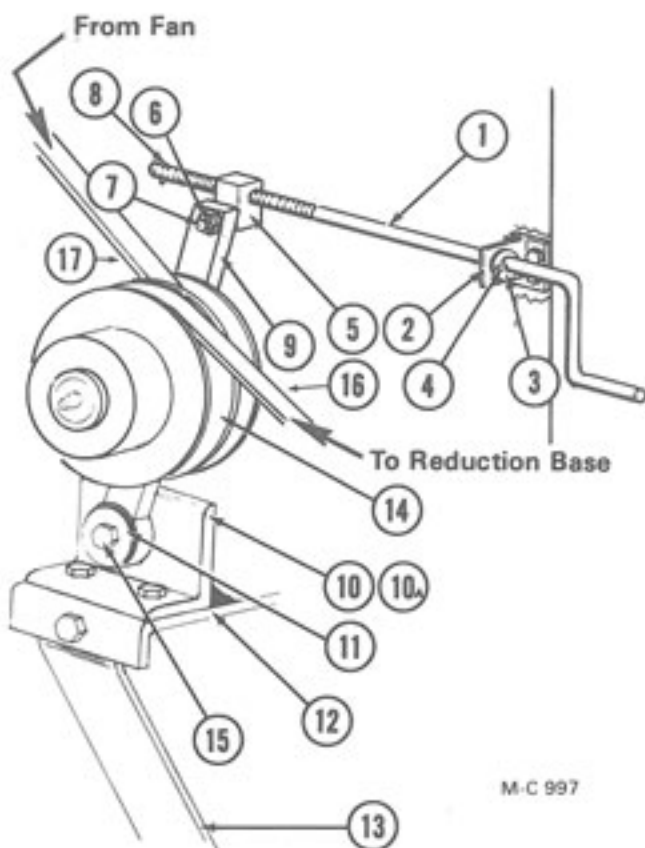

Ref.	Part No.	Qty.	Description
7	000 8141	1	1/2 - 13 x 2 1/2" Capscrew - Grd. 5
8	000 8199	1	1/8" x 1" Cotter Pin
9	128 1066	1	Variable Speed Arm w/Bushing
	128 6017	1	Bronze Bushing - 1 1/4" Bore
10	128 4060	1	Variable Speed Base
	000 8290	2	3/8 - 16 x 1 1/2" Capscrew
	000 8168	2	3/8 - 16 Flanged Locknut
10A	128 5053	1	Variable Arm Pivot
11	128 8165	2	Fender Washer - 1/2"
12	128 3444	1	Base Mount Bracket
	000 8121	2	3/8 - 16 x 1" Capscrew
	000 8168	2	3/8 - 16 Flanged Locknut
13	128 3445	1	Base Mt. Brkt. Support
	000 8121	2	3/8 - 16 x 1" Capscrew
	000 8168	2	3/8 - 16 Flanged Locknut
14	---	1	Variable Speed Pulley (See page 14)
	128 8130	1	3/8 - 16 x 1" Sq. Hd. Cup Pt. Set Screw
	000 8168	1	3/8 - 16 Flanged Locknut
15	128 8166	1	1/2 - 13 x 2 1/2" Capscrew - Grd. 5
16	001 6100	1	BX-56 Belt (Below S/N 39490)
	128 6121	1	BX-54 Belt (Above S/N 39489)
17	128 6105	1	B-63 Belt (Below S/N 39490)
	121 6104	1	BX-61 Belt (Above S/N 39489)

Ref.	Part No.	Qty.	Description
1	128 5192	1	Variable Speed Crank
2	125 3425	1	Variable Speed Brkt. Arm
3	000 8260	2	1/4" x 1 1/2" Roll Pin
4	000 8176	4	3/8" Flatwasher
5	121 5190	1	Variable Crank Nut
6	000 8163	1	1/2 - 13 Hex Nut

Variable Speed Pulley 128 6217

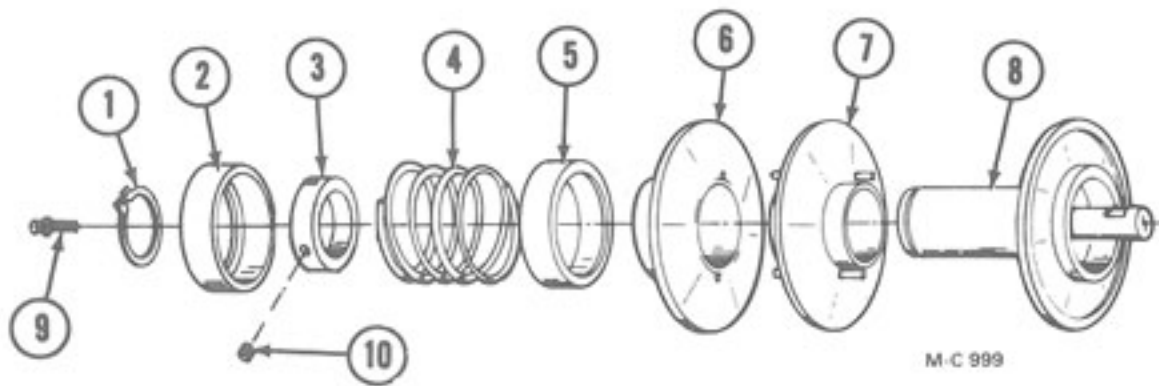

M-C 999

Ref.	Part No.	Qty.	Description	Ref.	Part No.	Qty.	Description
1	122 8919	1	Snap Ring	8	122 8914	1	Inner Sheave & Spindle Ass'y.
2	122 8918	1	Outer Spring Cover	9	000 8996	1	¼ - 28 NPT Straight Zerk
3	122 8906	1	Set Collar 1½" I.D.	10	000 8201	1	5/16 - 18 x 5/16" Knurled Cup Point Set Screw
4	122 8917	1	Spring				
5	122 8916	1	Inner Spring Cover				
6	122 8915	1	Outer Sheave w/Bushing				
7	122 8910	1	Center Sheave w/Bushing				

Variable Speed Pulley 128 6236

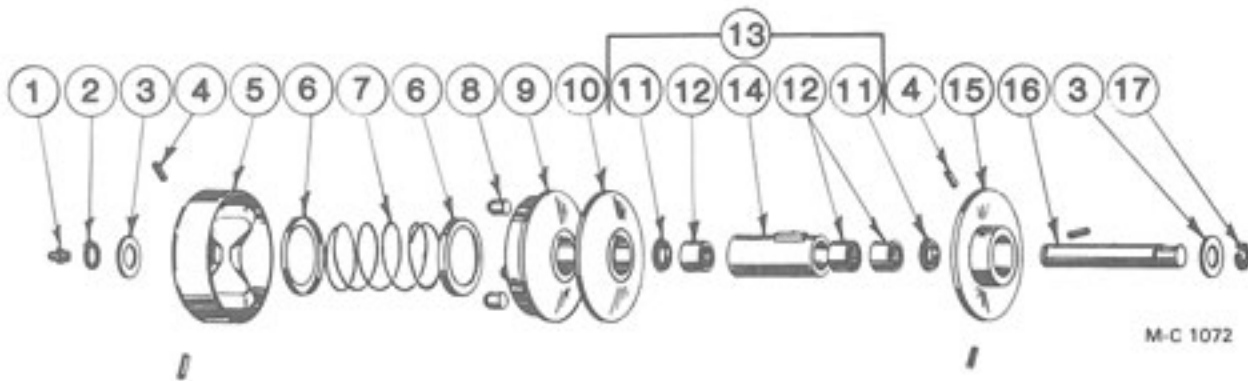

M-C 1072

Ref.	Part No.	Qty.	Description	Ref.	Part No.	Qty.	Description
1	122 6213	1	Straight 3/16 Drive Zerk	10	122 6215	1	Center Face Assembly
2	122 6200	1	Outer Retaining Ring	11	122 6209	2	Lube Seal
3	122 6201	2	Retaining Washer	12	122 6210	3	Sleeve Bearing
4	122 6203	6	Spring Pin	13	122 6211	1	Sleeve Assembly (Incl. ref. 11, 12 & 14)
5	122 6202	1	End Bell Assembly	14	122 6212	1	Slide Face Key
6	122 6204	2	Spring Retainer	15	122 6216	1	Fixed Face
7	122 6205	1	Spring	16	122 6214	1	Shaft Assembly (Incl. ref. 1, 2, 3 & 17)
8	122 6207	3	Cam Follower	17	122 6217	1	Inner Retaining Ring
9	122 6208	1	Slide Face Assembly (Incl. ref. 8)				

Fan Orifice and Burner

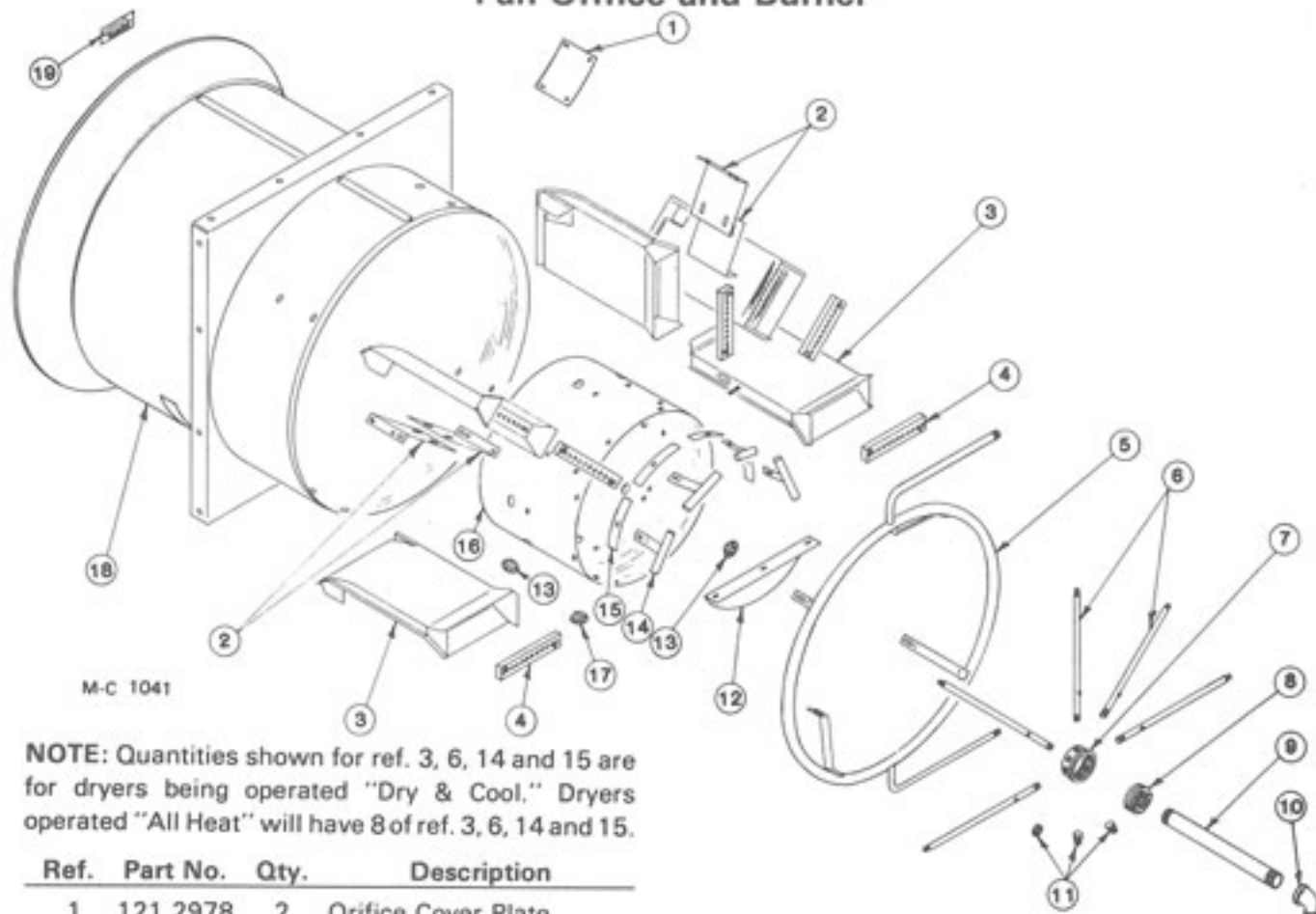

M-C 1041

NOTE: Quantities shown for ref. 3, 6, 14 and 15 are for dryers being operated "Dry & Cool." Dryers operated "All Heat" will have 8 of ref. 3, 6, 14 and 15.

Ref.	Part No.	Qty.	Description
1	121 2978	2	Orifice Cover Plate
	000 8212	8	1/4 - 20 x 1/2" Truss Hd. Screw
	000 8167	8	1/4 - 20 Flanged Locknut
2	121 4867	8	Air Chamber Mtg. Brkt.
	000 8106	8	5/16 - 18 x 3/4" Capscrew
	000 8103	16	5/16 - 18 x 1/2" Truss Hd. Screw
	000 8173	8	5/16" Flatwasher
	000 8169	24	5/16 - 18 Flanged Locknut
3	121 1241	5	Burner Unit (Incl. ref. 4)
	000 8169	5	5/16 - 18 Flanged Locknut
4	121 5988	5	Burner Insert
	000 8261	10	1/4" x 1" Sheet Metal Screw
5	121 0336	1	Vaporizer Ring (LP Gas)
	000 8104	4	5/16 - 18 x 3/4" Truss Hd. Screw
	000 8169	4	5/16 - 18 Flanged Locknut
6	---	---	Burner Lead Tube
	124 5701	5	1/8" Orifice - LP Gas (Above S/N 50308)
	123 5999	5	1/4" Orifice - Nat. Gas (Below S/N 50309)
	121 5987	5	3/16" Orifice LP Gas - Below S/N 50309 Nat. Gas - Above S/N 50308

Ref.	Part No.	Qty.	Description
7	121 5501	1	Burner Head
8	121 5738	1	3" to 1 1/4" Reducing Bushing
9	123 8065	1	1 1/4" x 1 1/4" Std. Nipple
10	123 8049	1	1 1/4" to 3/4" - 90° Std. Reducing Elbow (LP Gas)
	123 8051	1	1 1/4" - 90° Std. Elbow (Natural Gas)
11	001 8001	3	3/8" Std. Pipe Plug
12	128 2880	1	Burner Tube Baffle
	000 8103	3	5/16 - 18 x 1/2" Truss Hd. Screw
	000 8169	3	5/16 - 18 Flanged Locknut
13	128 6858	3	3/4" Steel Knock-Out Plug
14	121 0316	4	Ignition Tube
	000 8104	4	5/16 - 18 x 3/4" Truss Hd. Screw
	000 8169	4	5/16 - 18 Flanged Locknut
15	121 4468	4	Burner Locator Strip
16	121 0322	1	Burner Center Tube
17	121 6917	1	1/2" Steel Knock-Out Plug
18	128 0178	1	Fan Orifice Weld
19	121 8301	1	Counterclockwise Arrow Decal

Electrode and Flame Sensing Probe

Ref.	Part No.	Qty.	Description
1	124 6883	1	Style 1 Electrode - Below S/N 43657 (See note)
	000 8186	2	6 - 32 x 1/2" Std. Mach. Screw
	000 8185	2	6 - 32 Flanged Locknut
2	121 2640	1	Style 1 Electrode Mt. Plate - Below S/N 43657 (See note)
	000 8103	2	5/16 - 18 x 1/2" Truss Hd. Screw
	000 8169	2	5/16 - 18 Flanged Locknut
3	122 9004	1	Style 1 Electrode Ignition Wire Kit (For EM, EMS and B115 models below S/N 43657)
4	128 1461	1	Ignition Wire - Model B-12 (33")
5	128 1462	1	Ignition Wire (Ground) - Model B12 (75")
6	128 1463	1	Ignition Wire (Low Voltage) Model B12 (75")
7	122 9003	3	Style 2 Electrode Ignition and Remote Sensing Wire
8	124 6872	1	Flame Sensing Probe (Not on B12)
	121 6915	2	1/2" Locknut
9	128 6995	1	Style 2 Electrode - Above S/N 43656 (Not on B12)
	000 8186	2	6 - 32 x 1/2" Std. Mach. Screw
	000 8185	2	6 - 32 Flanged Locknut
10	128 2962	1	Style 2 Electrode Mt. Brkt. - Above S/N 43656
	000 8186	2	6 - 32 x 1/2" Std. Mach. Screw
	000 8185	2	6 - 32 Flanged Locknut
11	128 2936	1	Style 2 Electrode Mt. Plate - Above S/N 43656
	000 8103	2	5/16 - 18 x 1/2" Truss Hd. Screw
	000 8169	2	5/16 - 18 Flanged Locknut

NOTE: Two used on Model B12.

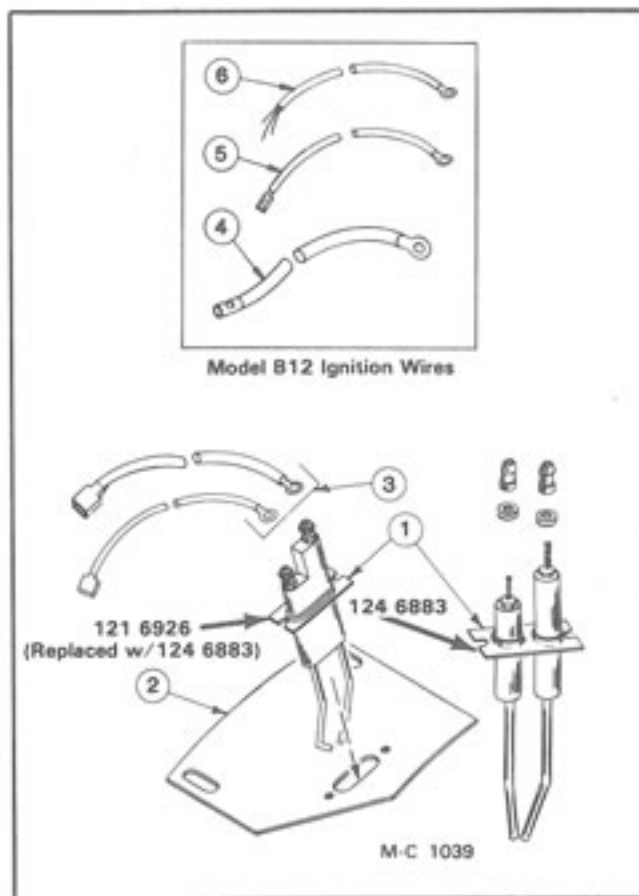

Style 1 Electrode - Below S/N 43657

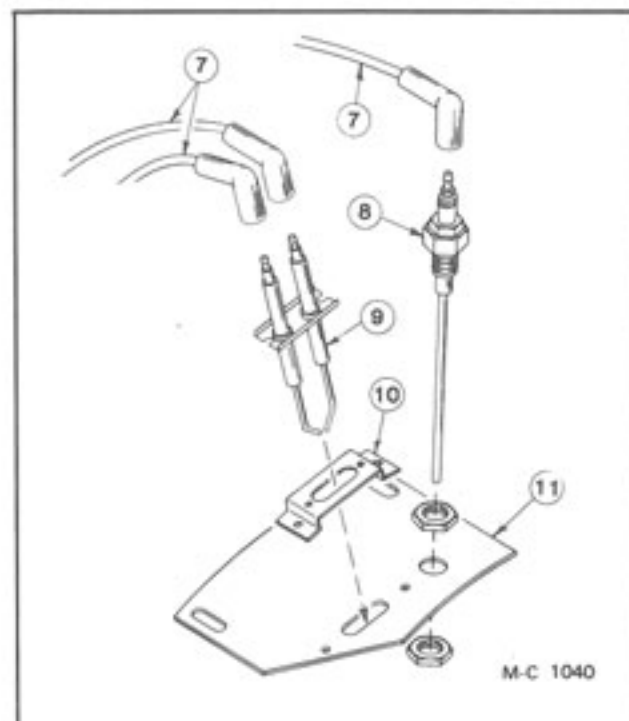

Style 2 Electrode - Above S/N 43656

Fan Drive - Electric (Model 375 EM & EMS)

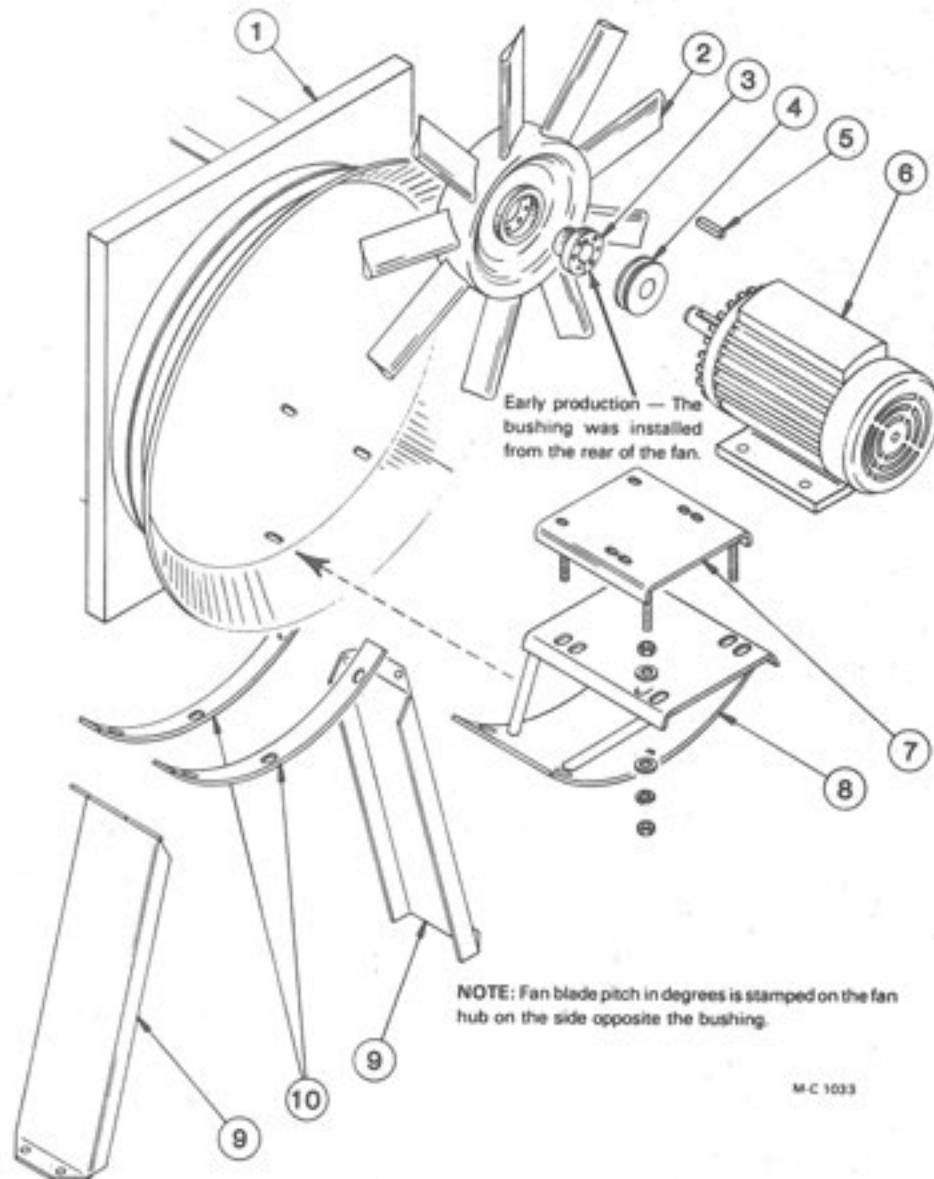

Ref.	Part No.	Qty.	Description
1	128 0178	1	Fan Orifice Weld.
2	121 0337	1	9 Blade - 18° Fan
3	121 6239	1	"SK" Bushing - 1 3/8" Bore
	121 8117	3	5/16" - 18 x 2" Socket Hd. Capscrew - Grd. 5
4	121 6233	1	"V" Pulley (4" OD x 1 3/8" bore)
5	001 5124	1	Key - 5/16" x 2 3/8"
6	--- ----	1	Fan Motor - 10HP (See page 34)
	000 8293	4	3/8 - 16 x 1 1/2" Capscrew - Full Thread
	000 8168	4	3/8 - 16 Flanged Locknut

Ref.	Part No.	Qty.	Description
7	128 0167	1	Motor Mount
	000 8182	4	3/4" Lockwasher
	000 8177	8	3/4" Flatwasher
	000 8165	8	3/4 - 10 Hex Nut
8	121 0258	1	Motor Mt. Base Weld.
9	128 4284	2	Mount Frame Strut
	000 8135	8	1/2 - 13 x 1" Capscrew - Grd .5
	000 8175	4	1/2" Flatwasher
	000 8170	8	1/2 - 13 Flanged Locknut
10	121 3356	2	Orifice Reinforcing Flange
	000 8136	5	1/2 - 13 x 1" Carriage Bolt
	000 8170	5	1/2 - 13 Flanged Locknut

Fan Drive - PTO (Model 375 B12 & B115)

NOTE: Fan blade pitch in degrees is stamped on the fan hub on the side opposite the bushing.

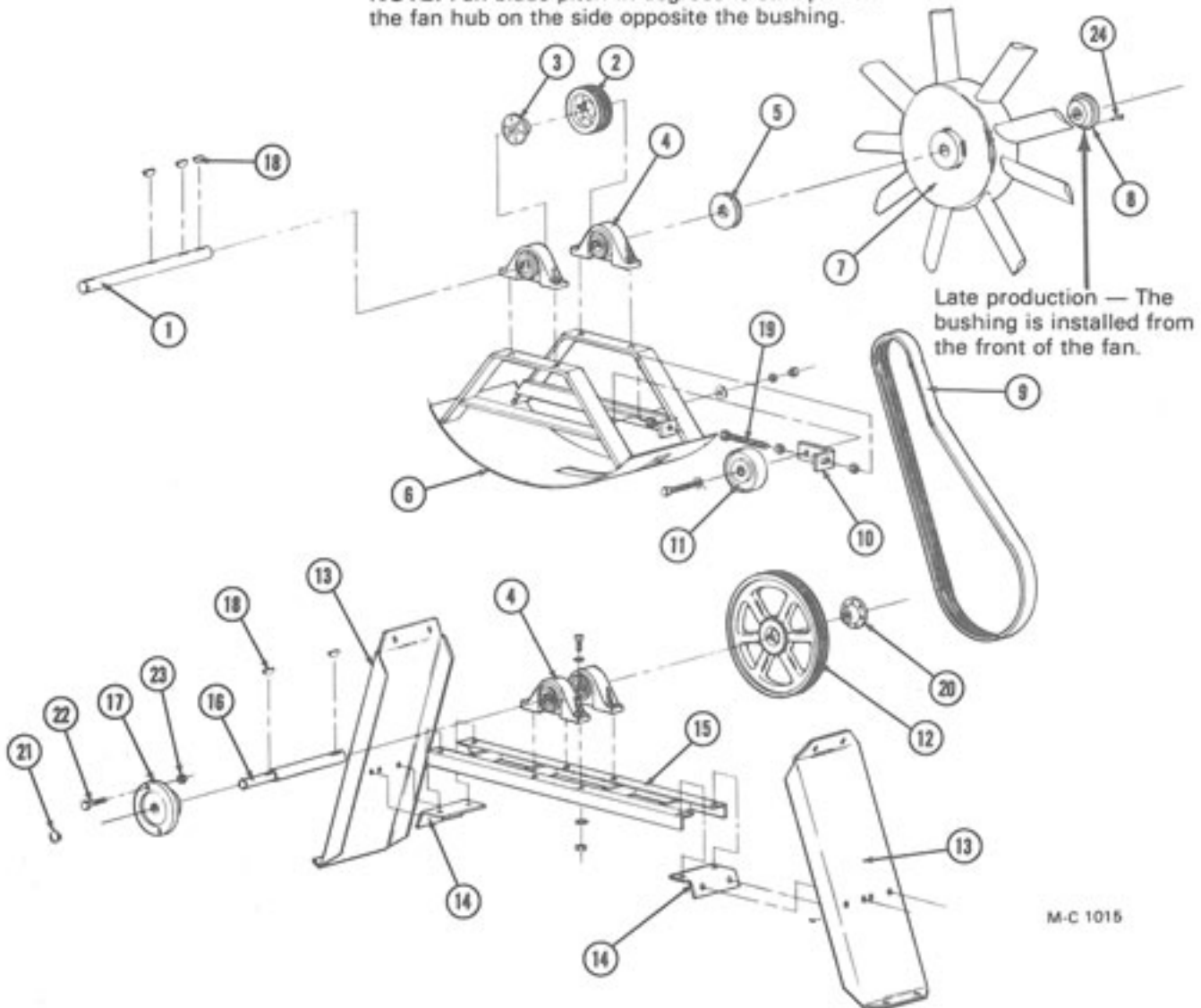

M-C 1015

Ref.	Part No.	Qty.	Description	Ref.	Part No.	Qty.	Description
1	121 5078	1	Fan Shaft	7	121 0337	1	9 Blade - 18° Fan
2	001 6203	1	4/3V/6.0 SK Sheave	8	121 6229	1	SK Bushing - 1 1/8" Bore (Incl. capscrews & lockwashers)
3	121 6229	1	SK Bushing - 1 1/8" Bore (Incl. capscrews & lockwashers)	9	128 6100	1	4/3V - 1000 Belt
4	121 6003	4	Pillow Block Brg. - 1 1/8" Bore	10	128 3402	1	Tensioner Bracket
	128 8166	8	1/2 - 13 x 2 1/2" Capscrew - Grd. 5	11	001 6201	1	Flat Idler w/Brgs.
	001 8257	16	1/2" SAE Flatwasher		001 6018	2	Bearing For 001 6201
	000 8180	8	1/2" Lockwasher		002 5600	1	Spacer For 001 6201
	000 8163	8	1/2 - 13 Hex Nut		000 8151	1	1/2 - 11 x 3 1/2" Capscrew - Grd. 5
5	120 6218	1	V-Pulley (1B x 4.4" OD x 1 1/8" Bore)		000 8299	4	3/8" SAE Lockwasher
6	128 0049	1	Fan Pedestal		000 8181	1	3/8" Lockwasher
					000 8164	1	1/2 - 11 Hex Nut
				12	121 6235	1	4/3V - 19" Pulley

Continued on next page

Fan Drive - PTO (Model 375 B12 & B115)

Ref.	Part No.	Qty.	Description	Ref.	Part No.	Qty.	Description
13	128 4284	2	Mount Frame Strut	17	001 7650	1	Shear Flange - 1 1/4" Bore
	000 8135	8	1/2 - 13 x 1" Capscrew - Grd. 5	18	001 8998	5	3/8" x 1 1/4" Woodruff Key
	000 8175	4	1/2" Flatwasher	19	123 8160	1	1/2 - 13 x 6" Capscrew - Full Thread
	000 8170	8	1/2 - 13 Flanged Nut		000 8175	1	1/2" Flatwasher
14	128 3940	2	Mount Frame Adj. Angle		000 8170	3	1/2 - 13 Flanged Locknut
	000 8138	4	1/2 - 13 x 1 1/2" Capscrew	20	121 6236	1	SF Bushing - 1 3/8" Bore
	000 8135	4	1/2 - 13 x 1" Capscrew - Grd. 5	21	001 8250	1	Snap Ring - 1 1/4"
	000 8175	4	1/2" Flatwasher	22	001 8133	4	Special Shear Bolts - 3/8 - 16 x 2 1/4"
	000 8170	8	1/2 - 13 Flanged Locknut	23	001 8149	4	3/8 - 16 Two-Way Locknut
15	128 0177	1	Mount Frame Base	24	121 8117	3	5/16 - 18 x 2" Socket Hd. Capscrew - Grd. 5
16	128 5065	1	Jackshaft				

Power Take-Off Shaft (Model 375 B12 & B115)

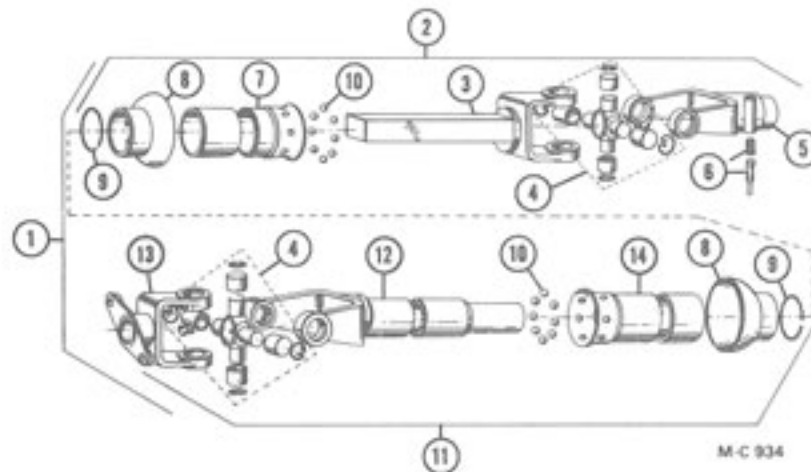

Ref.	Part No.	Qty.	Description	Ref.	Part No.	Qty.	Description
1	001 6600	1	PTO Shaft Complete	9	002 6625	2	External Snap Ring
2	002 6620	1	PTO Shaft (Tractor Half)	10	002 6606	16	3/8" Diameter Ball
3	002 6627	1	Male Shaft and Yoke	11	002 6621	1	PTO Shaft (Machine Half)
4	002 6628	2	Universal Joint Repair Kit	12	002 6622	1	Yoke and Tube
5	002 7651	1	QD Yoke w/Pin & Spring	13	002 7652	1	Flange Yoke - 1 1/4" Bore
6	002 6629	1	Saf-T-Pin & Spring Kit	14	002 6623	1	Male Guard Tube
7	002 6624	1	Female Guard Tube	—	001 8317	1	Danger - Rotating Drive Line - Decal
8	002 6626	3	Bell Shield				

Guards (Below S/N 46045)

Ref.	Part No.	Qty.	Description
1	128 4866	1	Front Guard Mt. Angle
2	128 4887	1	Front Guard Top
3	128 0083	1	PTO Shaft Guard ("B" Models)
4	128 5761	1	Front Guard Screen
	128 4890	1	Front Guard Hole Cover
5	121 8956	1	Fan Guard
6	121 8255	1	5/16 - 18 x 1 1/2" "J" Bolt
7	000 8173	1	5/16" Flatwasher
8	000 8166	1	5/16 - 18 Wing Nut

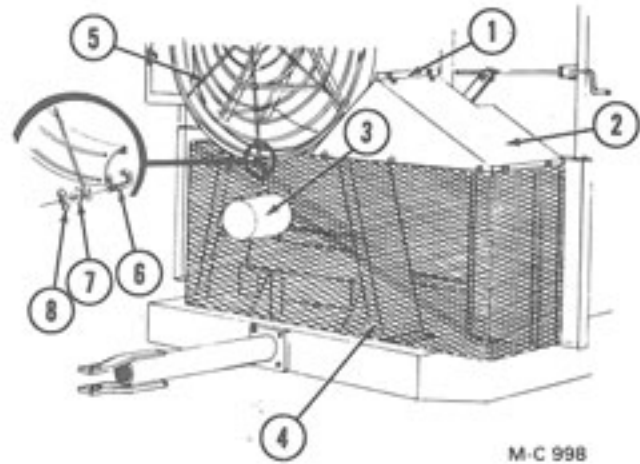

Guards (Above S/N 46044)

Ref.	Part No.	Qty.	Description
1	128 4897	1	Ratchet Guard - Right Side
	000 8106	2	5/16 - 18 x 3/4" Capscrew
	000 8173	2	5/16" Flatwasher
	000 8169	2	5/16 - 18 Flanged Locknut
2	128 5820	1	Front Guard Screen
	000 8106	4	5/16 - 18 x 3/4" Capscrew
	000 8173	4	5/16" Flatwasher
	000 8174	4	3/8" Flatwasher
	000 8169	4	5/16 - 18 Flanged Locknut
3	121 8957	6 ft.	Rubber Guard Edge
4	128 4899	1	Front Guard Mt. Angle
	001 8111	2	5/16 - 18 Clip Nut
	000 8184	1	8 - 18 x 1/2" Sheet Metal Screw
5	128 4900	1	Variable Speed Pulley Guard
	000 8106	3	5/16 - 18 x 3/4" Capscrew
	000 8173	3	5/16" Flatwasher
	000 8122	2	3/8 - 16 x 1" Carriage Bolt - Grd. 5
	000 8168	2	3/8 - 16 Flanged Locknut
6	001 8314	1	"Caution" Safety Decal
7	128 4891	1	Reduction Base Guard
	001 8111	1	5/16 - 18 Clip Nut
	121 8115	1	5/16" Push Nut
	000 8173	1	5/16" Flatwasher
	001 8114	1	5/16 - 18" x 3/4" Wing Nut
8	128 4898	1	Chain Guard - Left Side
	001 3302	1	Universal Angle Clip
	001 8111	2	5/16 - 18 Clip Nut
	000 8106	4	5/16 - 18 x 3/4" Capscrew
	000 8173	3	5/16" Flatwasher
	000 8169	3	5/16 - 18 Flanged Locknut

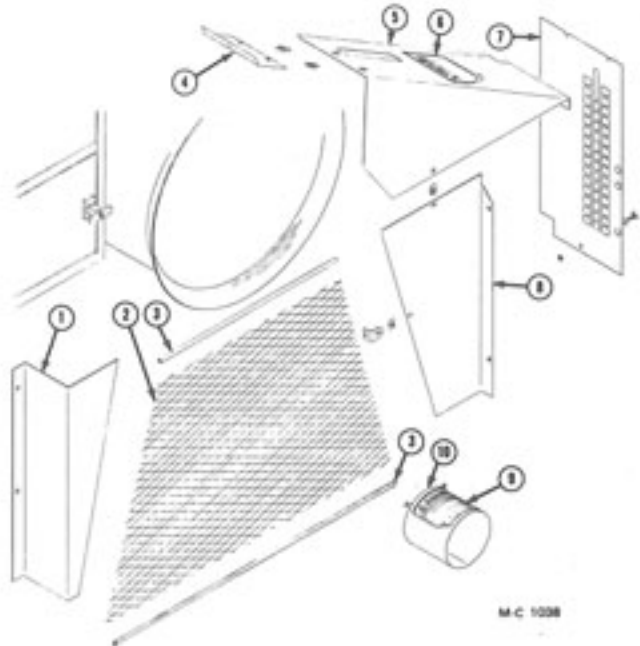

Ref.	Part No.	Qty.	Description
9	128 0083	1	PTO Shaft Guard ("B" Models)
10	001 8316	1	"Dryer" Safety Decal
11	121 8956	1	Fan Guard

Air Pressure, High Limit and Moisture Control Switches

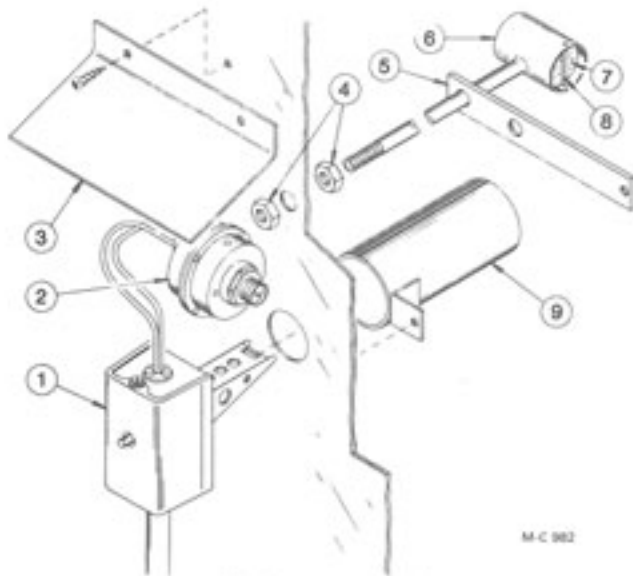

**Air Pressure and
High Limit Switches**

Ref.	Part No.	Qty.	Description
1	121 7018	1	High Limit Switch
2	121 6849	1	Air Pressure Switch
3	121 2946	1	High Limit Switch Cover (Above S/N 46798)
	128 0160	1	High Limit Switch Cover (Below S/N 46799)
4	121 8000	1	Pipe Locknut - 1/4"
5	121 2007	1	Air Pressure Tube Brkt.
6	121 0169	1	Air Pressure Tube

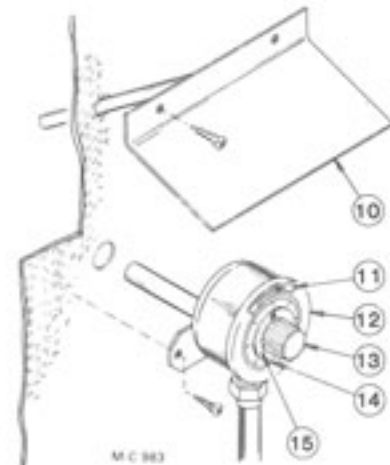

Moisture Control

Ref.	Part No.	Qty.	Description
7	121 5716	1	Air Pressure Tube Filter
8	---	1	Filter Retainer (Wire)
9	121 0081	1	High Limit Switch Shield
10	121 0031	1	Moisture Control Shield
11	121 8319	2	"Dry" Decal
12	121 6851	2	Moisture Control (Single range)
13	122 8986	2	Knob
14	122 7000	2	Dial Plate
15	122 6801	2	Moisture Control Switch

Thermometer

Ref.	Part No.	Qty.	Description
1	121 8973	1	Thermometer - 6' Capillary
—	121 2883	1	Sensing Bulb Brkt.
—	121 2882	1	Sensing Bulb Clip

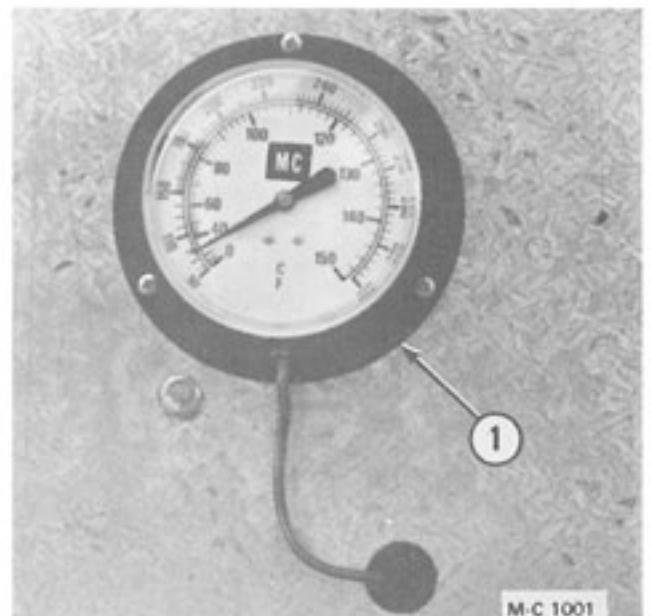

LP Gas Piping

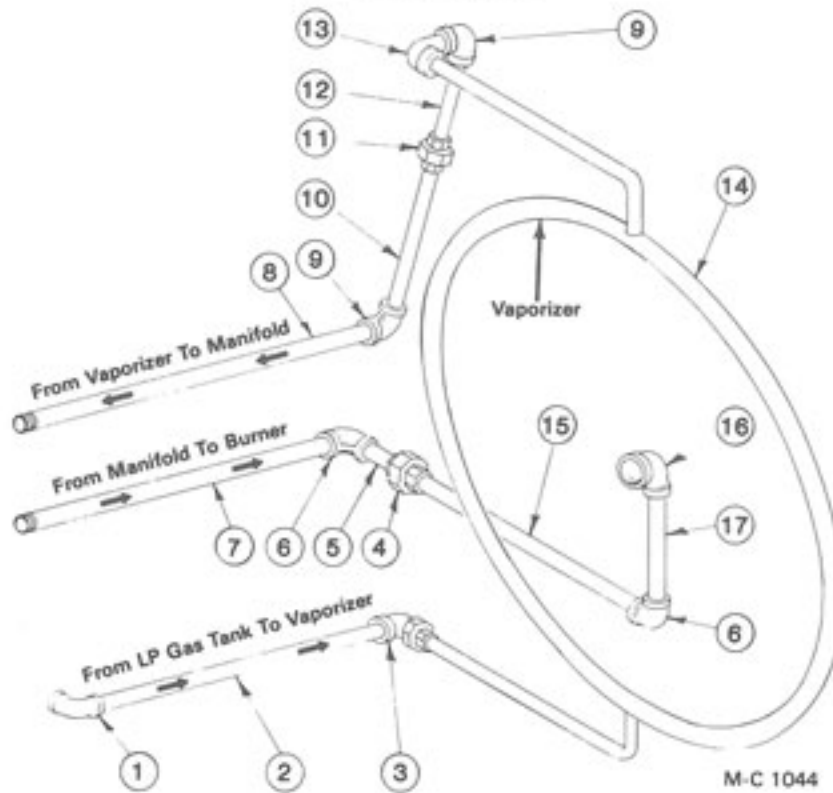

Ref.	Part No.	Qty.	Description
1	121 8036	1	½" - 90° Extra Hvy. Elbow
2	128 8045	1	½" x 17½" Extra Hvy. Nipple
3	128 8010	1	½" Extra Hvy. Union Elbow
4	121 8028	1	¾" Std. Union
5	121 8067	1	¾" x 1½" Std. Nipple
6	121 8074	2	¾" - 90° Std. Elbow
7	121 8019	1	¾" x 20" Std. Nipple
8	125 8064	1	¾" x 19½" Extra Hvy. Nipple
9	121 8027	2	¾" - 90° Extra Hvy. Elbow
10	121 8083	1	¾" x 9" Extra Hvy. Nipple
11	121 8072	1	¾" Extra Hvy. Union
12	121 8098	1	¾" x 5" Extra Hvy. Nipple
13	125 8063	1	¾" - 90° Extra Hvy. Street Elbow
14	121 0336	1	Vaporizer Ring
15	128 8038	1	¾" x 18½" Std. Nipple
16	123 8049	1	1¼" to ¾" - 90° Std. Reducing Elbow
17	121 8049	1	¾" x 6½" Std. Nipple
18	121 7005	1	Inlet Hose - ½" ID x 12"

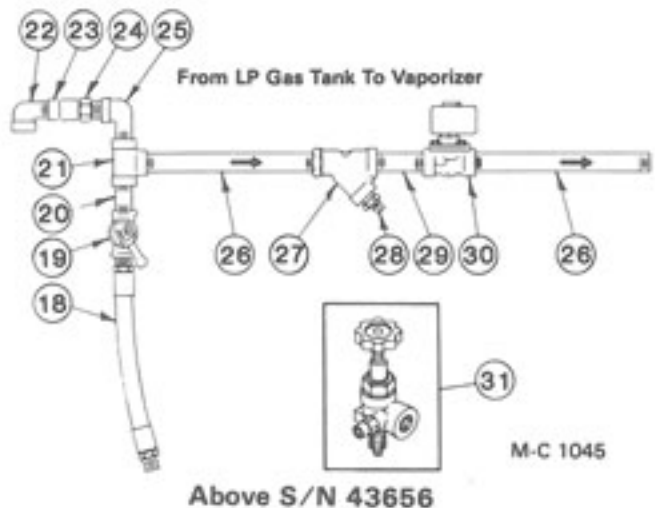
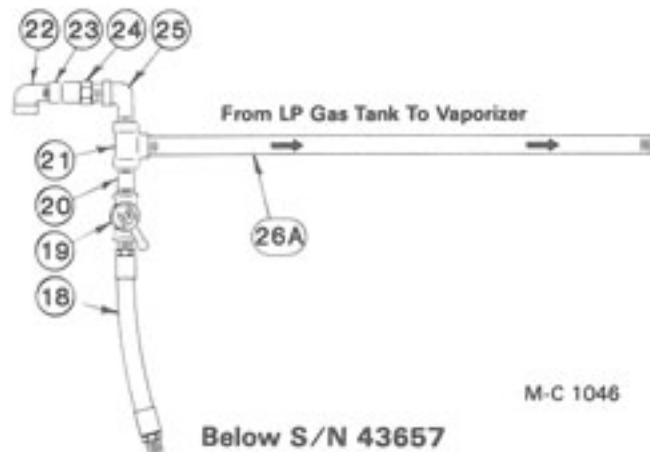

Continued on next page

LP Gas Piping

Ref.	Part No.	Qty.	Description	Ref.	Part No.	Qty.	Description
19	121 7015	1	Hand Valve - ½"	26A	128 8036	1	½" x 28½" Extra Hvy. Nipple
20	120 8047	1	½" x 2" Extra Hvy. Nipple	27	123 7007	1	½" Strainer
21	120 8035	1	½" Extra Hvy. Tee	28	001 8001	1	⅜" Std. Pipe Plug
22	121 8048	1	½" - 90° Std. Street Elbow	29	125 8007	1	½" x 4½" Extra Hvy. Nipple
23	121 7014	1	Relief Valve Adapter	30	125 7082	1	½" Solenoid Valve - 115V
24	121 7013	1	Relief Valve		123 6890	1	½" Solenoid Valve - 12V-DC
25	121 8071	1	½" - 90° Extra Hvy. Street Elbow	31	121 7021	1	LP Gas Tank Valve
26	125 8010	2	½" x 10" Extra Hvy. Nipple				

Solenoid Valve Repair Kit

The repair kit and coil for the ½" solenoid valve (ref. 30) is shown on page 36.

Natural Gas Piping (Manifold to Burner)

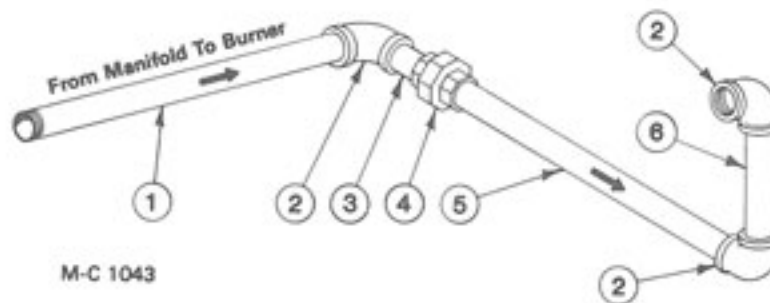

Ref.	Part No.	Qty.	Description
1	123 8058	1	1¼" x 19½" Std. Nipple
2	123 8051	3	1¼" - 90° Std. Elbow
3	128 8001	1	1¼" x 4½" Std. Nipple
4	123 8053	1	1¼" Std. Union
5	123 8065	1	1¼" x 14" Std. Nipple
6	123 8073	1	1¼" x 6½" Std. Nipple

Natural Gas Manifold

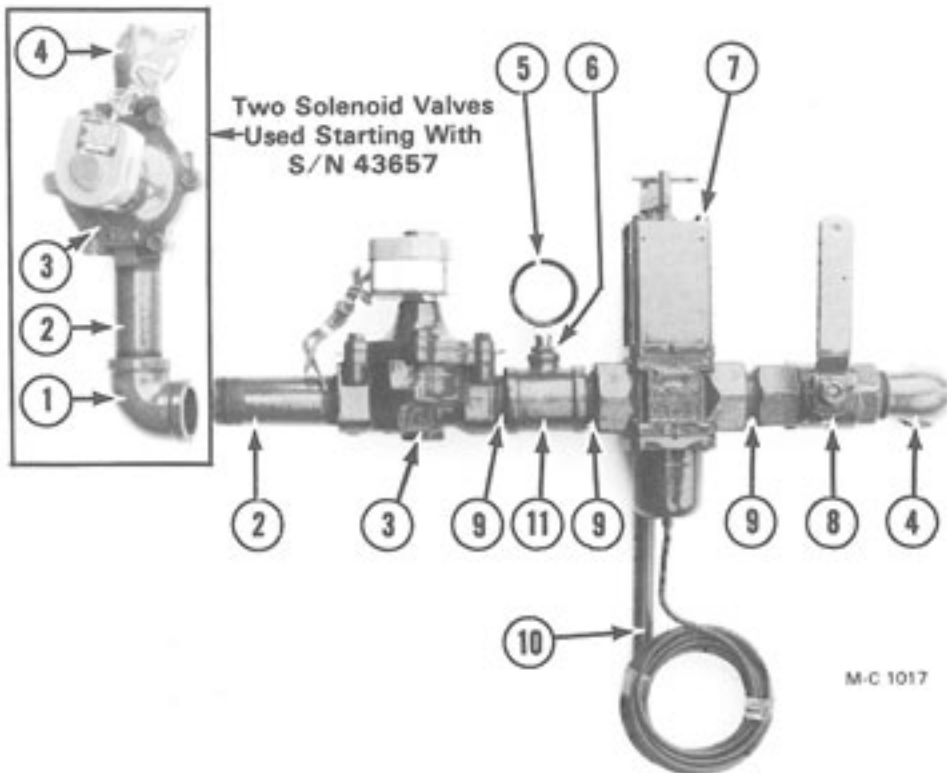

M-C 1017

Ref.	Part No.	Qty.	Description
1	123 8051	1	1 1/4" - 90° Elbow
2	128 8001	2	1 1/4" x 4 1/2" Std. Nipple
3	128 7001	2	1 1/4" Solenoid Valve - 115V
	127 7001	2	1 1/4" Solenoid Valve - 12V
4	123 8062	2	1 1/4" - 90° Street Elbow
5	120 7002	1	Pressure Gauge
6	127 8132	1	3/8" to 1/4" Reducing Bushing
7	123 7002	1	1 1/4" Modulating Valve w/ 90°-210°F Power Element - Below S/N 46799
	123 7024	1	1 1/4" Modulating Valve w/ 140°-250°F Power Element - Above S/N 46798
8	123 7003	1	1 1/4" Hand Valve
9	123 8069	3	1 1/4" Close Nipple
10	122 7023	1	Power Element 90°-210°F - Code "B" (15' Capillary)
	122 7022	1	Power Element 140°-250°F - Code "D" (10' Capillary)
	122 7036	1	Power Element 140°-250°F - Code "D" (15' Capillary)
11	127 8131	1	1 1/4" x 1 1/4" x 3/8" Tee

Repair Kits

Repair kits for modulating valves and solenoid valves are shown on pages 36 and 37.

D260 Rev. 1, December 1990

LP Gas Manifold (Before 1978)

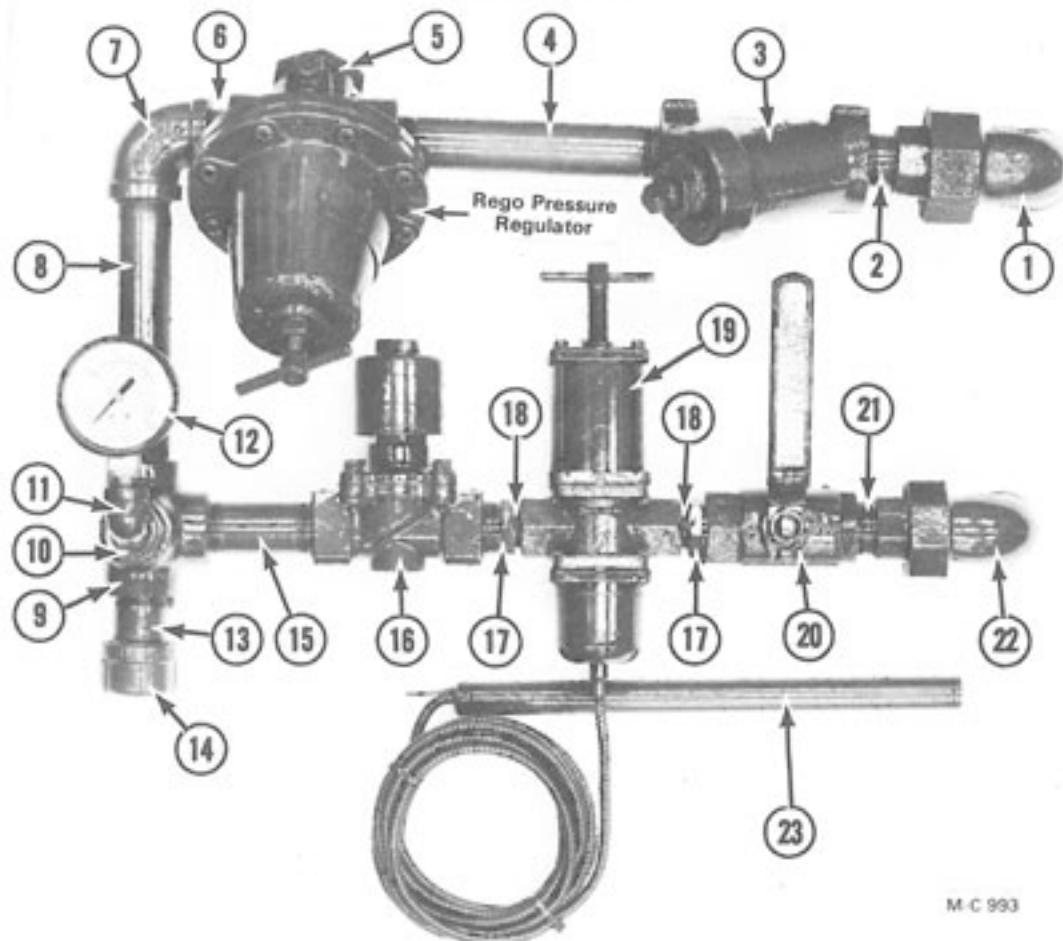

M-C 993

Ref.	Part No.	Qty.	Description	Ref.	Part No.	Qty.	Description
1	128 8019	1	3/4" Extra Hvy. Union Elbow	12	120 7002	1	Pressure Gauge
2	121 8005	1	3/4" x 1 1/2" Extra Hvy. Nipple	13	121 8007	1	3/4" Close Nipple
3	121 8060	1	3/4" Strainer	14	121 8050	1	3/4" Std. Pipe Cap
4	128 8006	1	3/4" x 6" Extra Hvy. Nipple	15	121 8069	1	3/4" x 3" Std. Nipple
5	121 7006	1	LP Gas Pressure Regulator (See note)	16	121 7002	1	3/4" Solenoid Valve - 115V
6	121 8067	1	3/4" x 1 1/2" Std. Nipple		121 7025	1	3/4" Solenoid Valve - 12V
7	121 8074	1	3/4" - 90° Std. Elbow	17	121 8029	2	3/4" to 1/2" Reducing Bushing
8	127 8008	1	3/4" x 6" Std. Nipple	18	121 8013	2	1/2" Close Nipple
9	128 8035	1	3/4" Side Outlet Tee	19	121 7012	1	1/2" Modulating Valve w/ 90°-210°F Power Element
10	121 8030	1	3/4" to 1/4" Reducing Bushing	20	121 7011	1	3/4" Hand Valve
11	121 8039	1	1/4" - 90° Street Elbow	21	121 8007	1	3/4" Close Nipple
				22	128 8039	1	3/4" Std. Union Elbow
				23	122 7002	1	Power Element 90°-210°F Code "B" (10' Capillary)
					122 7014	1	Power Element 140°-250°F Code "D" (10' Capillary)

NOTE: The Rego Gas Pressure Regulator 121 7006 has been replaced with the Fisher Gas Pressure Regulator 128 7005 shown on page 26A.

Repair Kits

Repair kits for modulating valves, solenoid valves and LP gas pressure regulators are shown on pages 36 and 37.

LP Gas Manifold (1978 thru 1989)

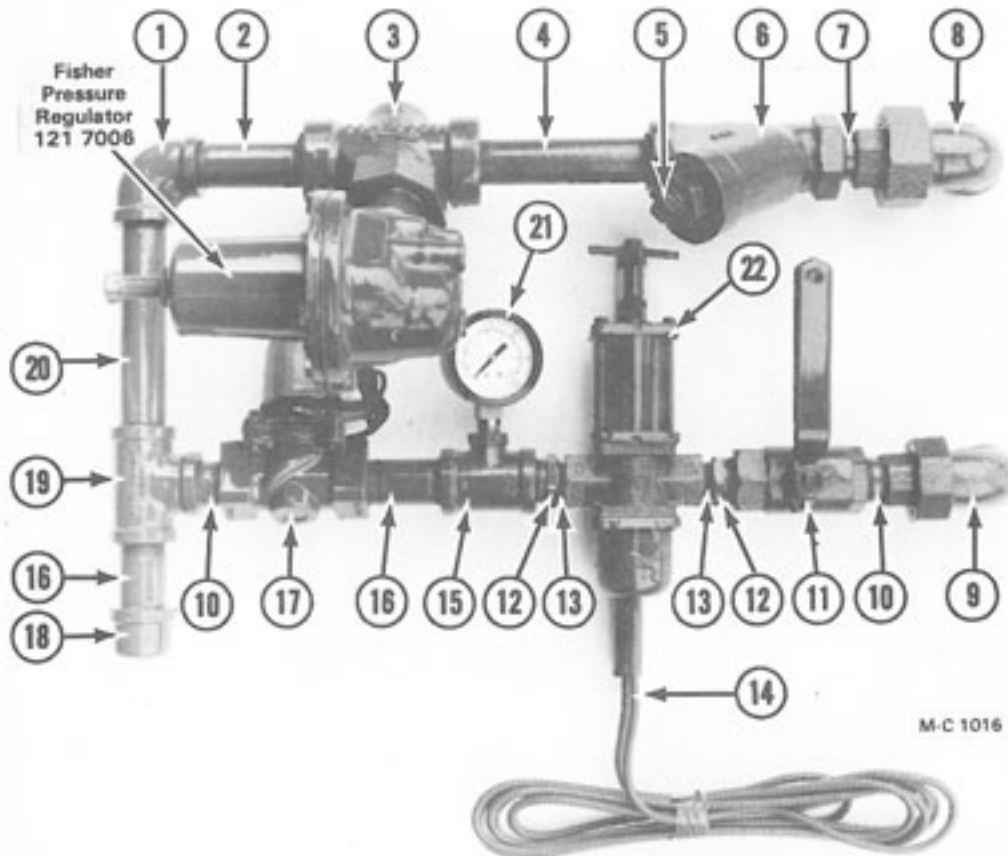

Ref.	Part No.	Qty.	Description
1	121 8074	1	3/4" - 90° Std. Elbow
2	128 8031	1	3/4" x 3 1/2" Std. Nipple
3	121 7006	1	LP Gas Pressure Regulator (See note)
4	121 8098	1	3/4" x 5" Extra Hvy. Nipple
5	001 8001	1	3/8" Pipe Plug
6	121 8060	1	3/4" Strainer
7	121 8005	1	3/4" x 1 1/2" Extra Hvy. Nipple
8	128 8019	1	3/4" Extra Hvy. Union Elbow
9	128 8039	1	3/4" Std. Union Elbow
10	121 8067	2	3/4" x 1 1/2" Std. Nipple
11	121 7011	1	3/4" Hand Valve
12	121 8029	2	3/4" to 1/2" Reducing Bushing
13	121 8013	2	1/2" Close Nipple

Ref.	Part No.	Qty.	Description
14	122 7002	1	Power Element 90°-210°F Code "B" (10' Capillary)
	122 7014	1	Power Element 140°-250°F Code "D" (10' Capillary)
15	123 8092	1	3/4" x 3/4" x 1/4" Std. Tee
16	121 8002	2	3/4" x 2 1/2" Std. Nipple
17	121 7002	1	3/4" Solenoid Valve - 115V
	121 7025	1	3/4" Solenoid Valve - 12V
18	121 8050	1	3/4" Pipe Cap
19	121 8070	1	3/4" Std. Tee
20	127 8008	1	3/4" x 6" Std. Nipple
21	120 7002	1	Pressure Gauge
22	121 7012	1	1/2" Modulating Valve w/ 90°-210°F Power Element Below S/N 46799
	121 7024	1	1/2" Modulating Valve w/ 140°-250°F Power Element Above S/N 46798

NOTE: Gas Pressure Regulator 121 7006 has been replaced with Gas Pressure Regulator 128 7005 shown on page 26A.

Repair Kits

Repair kits for modulating valves, solenoid valves and LP gas pressure regulators are shown on pages 36 and 37.

LP Gas Manifold (Starting in 1990)

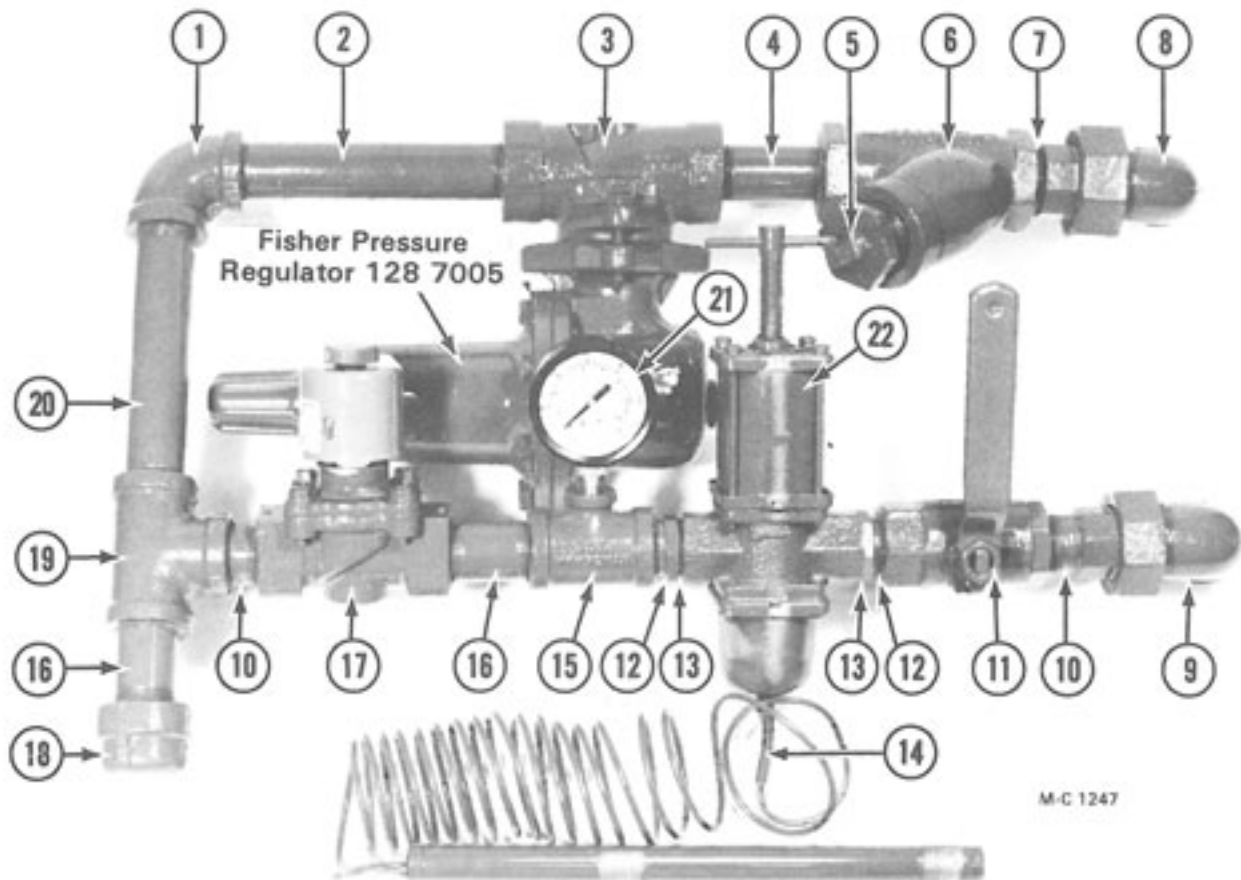

Ref.	Part No.	Qty.	Description	Ref.	Part No.	Qty.	Description
1	121 8074	1	3/4" - 90° Std. Elbow	14	122 7014	1	Power Element 140°-250°F Code "D" (10' Capillary)
2	121 8089	1	3/4" x 5" Std. Nipple		122 7002	1	Power Element 90°-210°F Code "B" (10' Capillary)
3	128 7005	1	LP Gas Pressure Regulator	15	123 8092	1	3/4" x 3/4" x 1/4" Std. Tee
4	121 8092	1	3/4" x 4" Extra Hvy. Nipple	16	121 8002	2	3/4" x 2 1/2" Std. Nipple
5	001 8001	1	3/8" Pipe Plug	17	121 7002	1	3/4" Solenoid Valve - 115V
6	121 8060	1	3/4" Strainer		121 7025	1	3/4" Solenoid Valve - 12V
7	121 8005	1	3/4" x 1 1/2" Extra Hvy. Nipple	18	121 8050	1	3/4" Pipe Cap
8	128 8019	1	3/4" Extra Hvy. Union Elbow	19	121 8070	1	3/4" Std. Tee
9	128 8039	1	3/4" Std. Union Elbow	20	127 8008	1	3/4" x 6" Std. Nipple
10	121 8067	2	3/4" x 1 1/2" Std. Nipple	21	120 7002	1	Pressure Gauge
11	121 7011	1	3/4" Hand Valve	22	121 7024	1	1/2" Modulating Valve w/ 140°-250°F Power Element
12	121 8029	2	3/4" to 1/2" Reducing Bushing				
13	121 8013	2	1/2" Close Nipple				

Repair Kits

Repair kits for modulating valves, solenoid valves and LP gas pressure regulators are shown on pages 36 and 37.

This page intentionally blank.

Control Cabinet

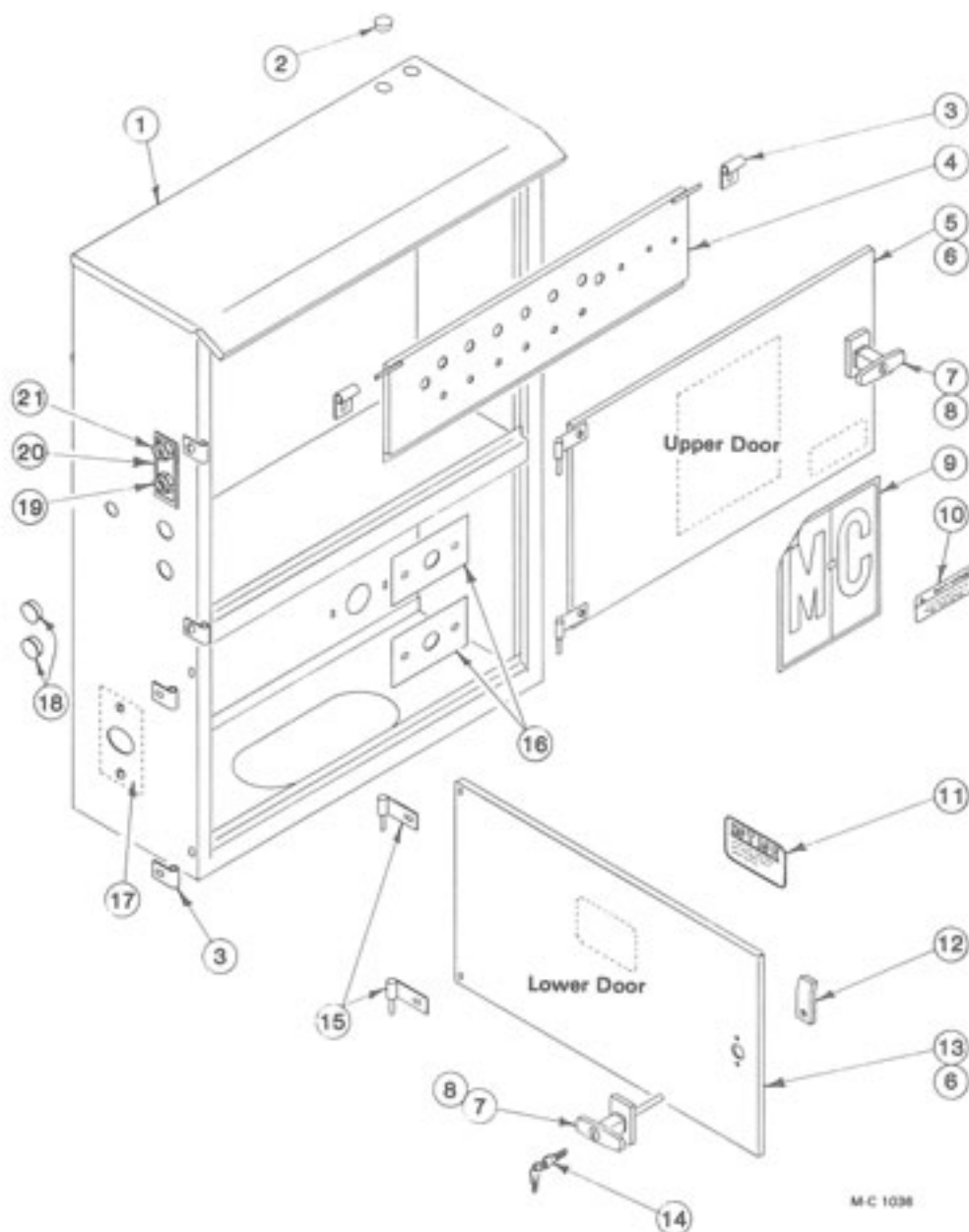

M-C 1038

Ref.	Part No.	Qty.	Description	Ref.	Part No.	Qty.	Description
1	128 0240	1	Control Cabinet Weld.	9	001 8302	1	M-C Decal - 8-3/16" x 9"
2	121 8600	1	1/2" Hole Plug	10	121 8316	1	Dryer Warning Decal
3	121 4656	6	Door Hinge w/o Pin	11	001 8310	1	Machine Warranty Decal
4	021 0013	1	Hinged Light Door	12	128 3425	2	Door Handle Cam
5	021 1044	1	Upper Door Ass'y. (Incl. ref. 6, 7, 9, 10 & 15)	13	021 1037	1	Lower Door Ass'y. (Incl. ref. 6, 7, 11 & 15)
6	021 4769	2	Door - Upper and Lower	14	122 8900	1	Door "T" Handle Key
7	124 1021	2	Door "T" Handle Ass'y. (Incl. ref. 12 cam, ref. 14 keys and mtg. hdwe.) Lever type handle no longer available.	15	021 0012	4	Door Hinge w/Pin
8	128 8946	2	Door "T" Handle w/Keys (Less ref. 12 cam)	16	121 4818	2	3/4" LP Gas Pipe Seal
				17	128 4848	1	Hole Cover
				18	120 6928	2	1-3/16" Hole Plug
				19	128 6844	1	Start Button - Black
				20	128 8315	1	Start & Stop Plate - Fan 1
				21	128 6845	1	Stop Button - Red

Electrical Components In Control Cabinet

(Model 375 EM, EMS & B115)

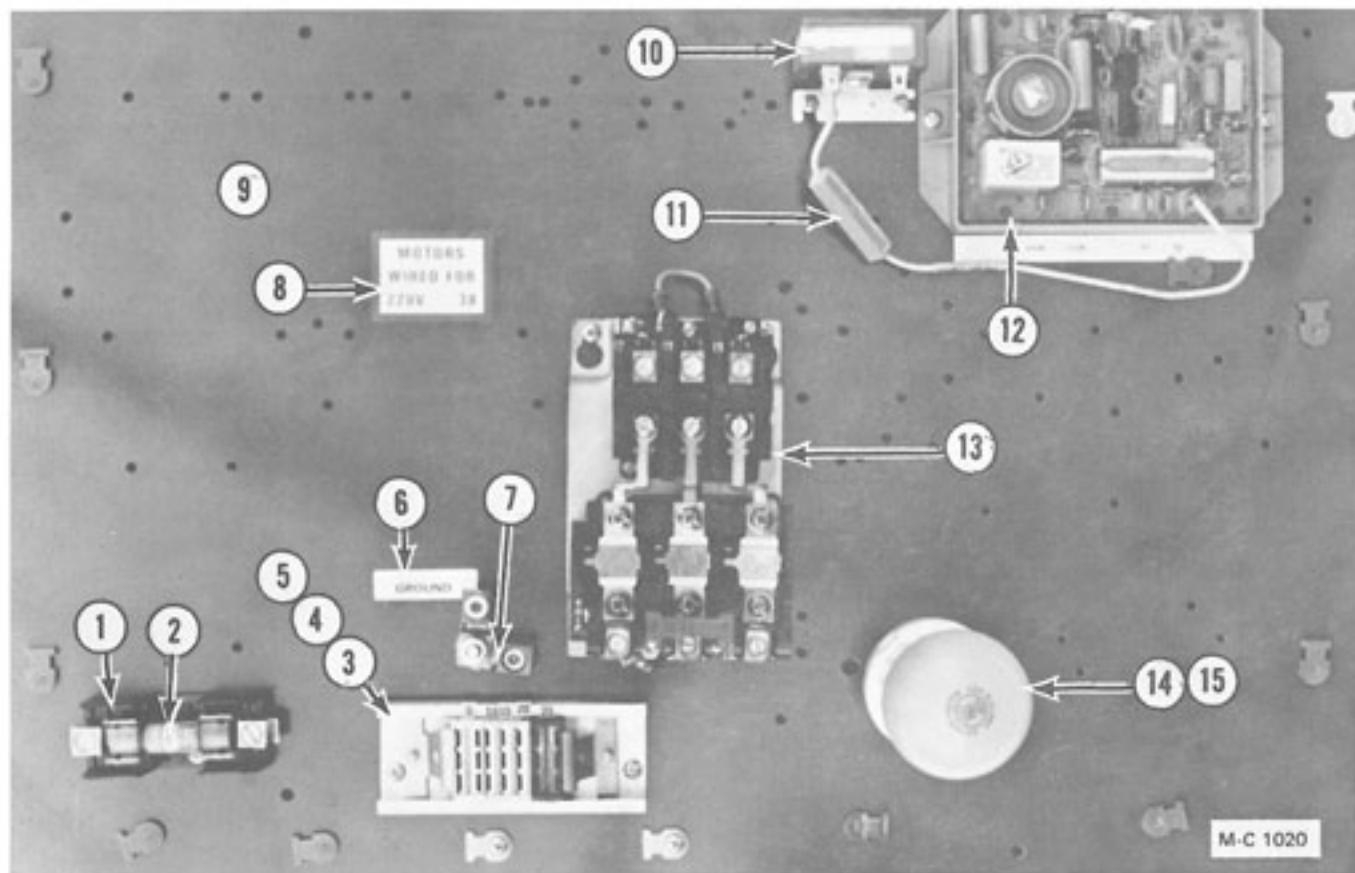

Ref.	Part No.	Qty.	Description
1	128 6851	1	Fuse Holder - Not on B115
2	128 6967	1	Fuse - NON - 10 Amp (or EON) - Not on B115
3	128 1429	1	Terminal Track Ass'y. (Incl. cages & end locks)
4	203 5200	1	Track - 1 7/8" x 4 1/2"
	121 6818	2	End Lock Ass'y.
5	121 6839	1	6 Way Cage Ass'y. - White
	121 6824	3	3 Way Cage Ass'y. - Yellow
	121 6830	1	6 Way Cage Ass'y. - Black
6	128 8349	1	"Ground" Decal
7	125 6918	1	Grounding Lug
8	121 8327	1	220V Single Phase Decal
	121 8329	1	220V Three Phase Decal
	121 8328	1	440V Three Phase Decal
9	021 4770	1	Component Mt. Board
10	124 6831	1	10 Second Ignition Timer - Above S/N 47163

Ref.	Part No.	Qty.	Description
11	127 6812	1	Resistor (10W-3K OHM) - Above S/N 47163
12	121 6925	1	115V Ignition Board (Incl. ign. reset - 0.1 amp)
13	---	1	Fan Motor Magnetic Starter, see page 34 (Not on B115)
14	124 6850	1	25W Rough Service Bulb
	124 6842	1	50W Rough Service Bulb
15	124 6841	1	Light Bulb Socket

B115 Parts Not Shown

—	121 1176	1	Pig Tail Ass'y. (Incl. Wire, Plug & Fuse)
—	121 6803	1	Male 3 Wire Plug w/o 10 Amp. Fuse
—	121 6805	1	10 Amp. GLH Fuse

Electrical Components In Control Cabinet (Model 375 B12)

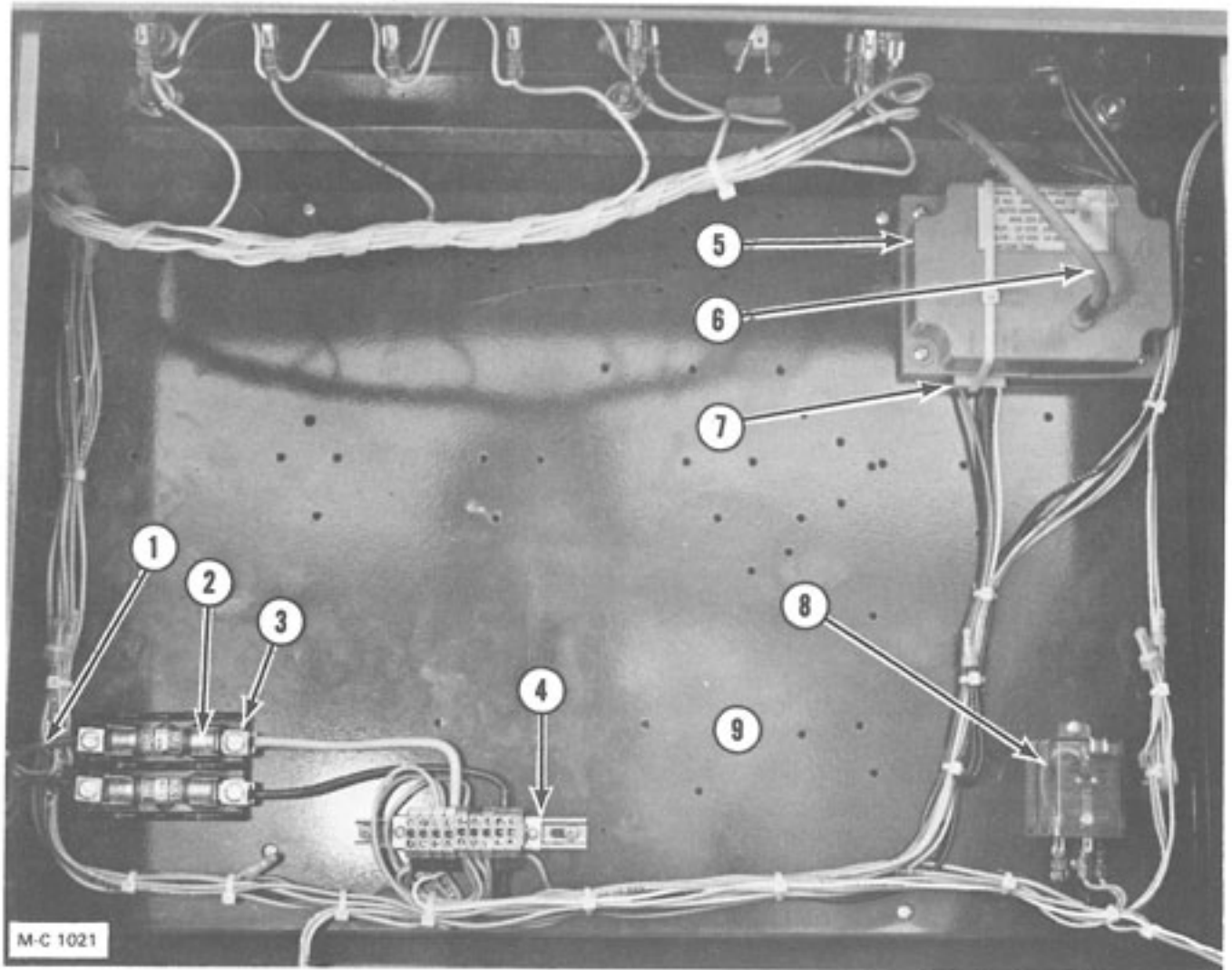

Ref.	Part No.	Qty.	Description
1	128 1216	1	Battery Cable Ass'y.
2	128 6967	2	Fuse - NON - 10 Amp. (or EON)
3	203 6801	1	Double Fuse Block
4	128 1402	1	Terminal Track Ass'y.
5	121 6962	1	12V Ignition Board
6	128 1461	1	Ignition Wire (33")
7	121 6964	1	Low Voltage Wire Ass'y.
8	121 6990	1	12V Relay
9	021 4770	1	Component Mt. Board

Control Panel Lights and Switches

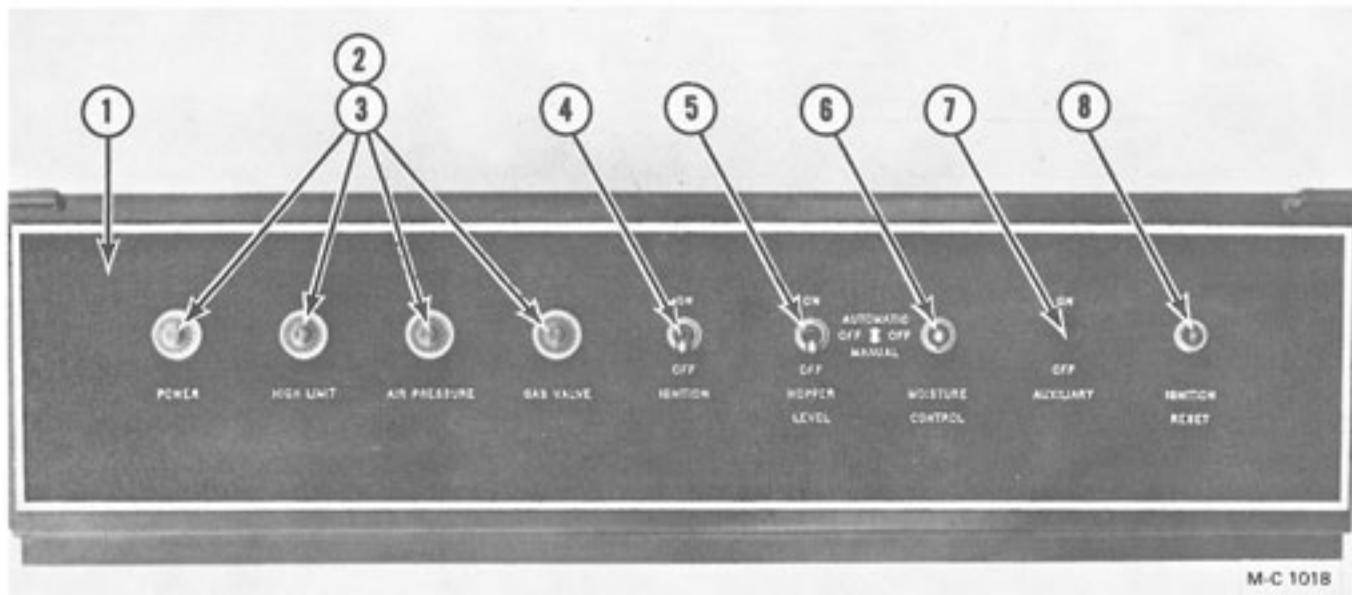

M-C 1018

Ref.	Part No.	Qty.	Description
1	128 8346	1	Light Bezel
2	121 6808	4	125V Indicator Lamp Ass'y. (Incl. lamp & lens)
	122 6810	4	125V Indicator Lamp
	122 6800	4	Indicator Lamp Lens (Clear)
3	128 6860	4	12V Indicator Lamp Ass'y. (Incl. lamp & lens)
	121 6978	4	12V Indicator Lamp
	122 6800	4	Indicator Lamp Lens (Clear)
4	121 6815	1	ON-OFF Toggle Switch (SPST)
5	121 6806	1	ON-OFF-ON Toggle Switch (SPDT)
6	121 6807	1	ON-OFF-ON Toggle Switch (DPDT)
7	121 6850	—	Hole Plug - 1/2"
8	122 6814	1	Ignition Reset (0.1 Amp.) - Not used on B12 model
9	128 6845	1	Stop Button - Red
10	128 8315	1	Start & Stop Plate - Fan 1
11	128 6844	1	Start Button - Black
12	120 6928	2	1-3/16" Hole Plug



M-C 1019

Hopper

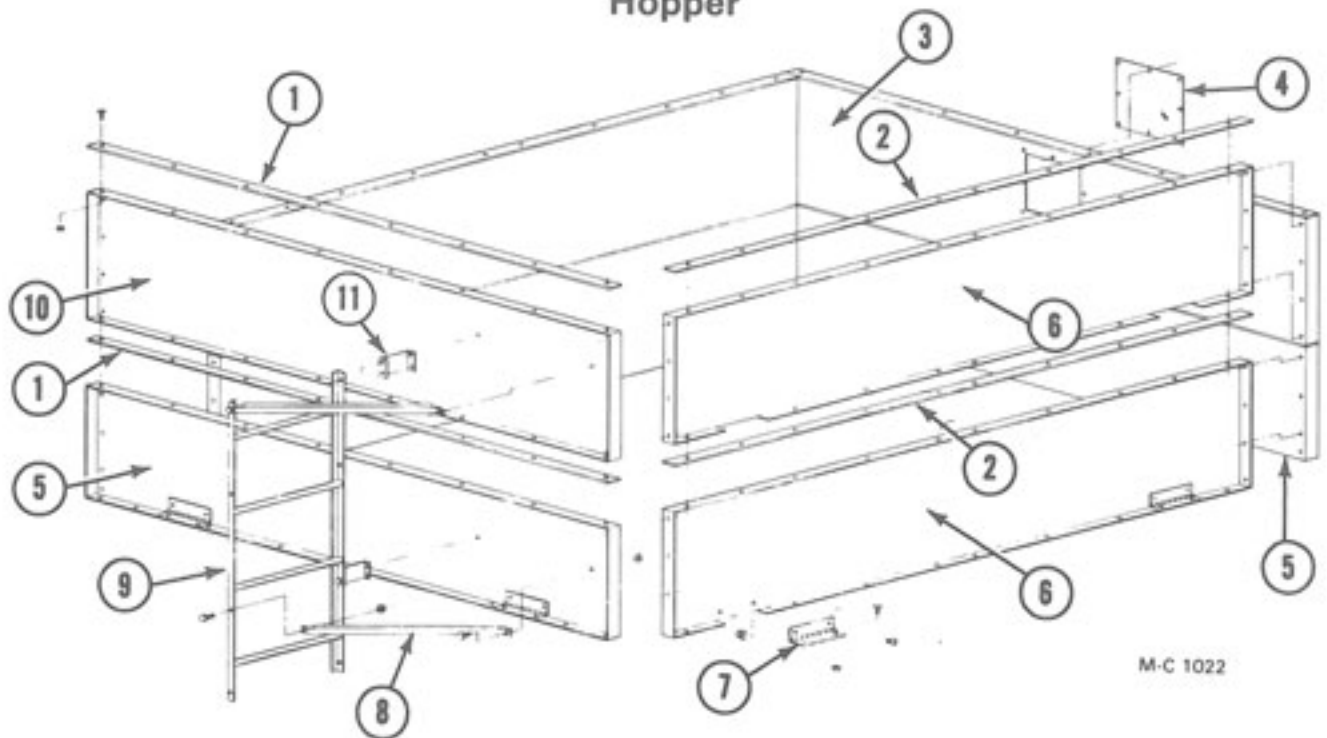

M-C 1022

Ref.	Part No.	Qty.	Description
1	128 2052	4	Hopper End Panel Stiffener
2	128 2051	4	Hopper Side Panel Stiffener
3	128 4808	1	Load Switch Hopper Panel - Below S/N 46799
	124 4805	1	Load Switch Hopper Panel - Above S/N 46798
4	128 2996	1	Cover Plate - Below S/N 46799
5	128 4823	2	Hopper End Panel - Lower (Front & Rear)
6	128 4824	4	Hopper Side Panel
7	128 8957	8	Hopper Hinge

Ref.	Part No.	Qty.	Description
8	128 2661	5	Ladder Mtg. Angle
9	128 0162	1	Ladder - 4'
	128 0163	1	Ladder - 9'
10	128 4822	1	Hopper End Panel - Rear
11	128 2660	5	Ladder Mtg. Brkt.
—	000 8121	11	3/8 - 16 x 1" Capscrew
—	000 8119	79	3/8 - 16 x 3/4" Capscrew
—	000 8134	24	3/8 - 16 x 3/4" Truss Hd. Screw
—	000 8174	27	3/8" Flatwasher
—	000 8168	114	3/8 - 16 Flanged Locknut
—	000 8103	10	5/16 - 18 x 1/2" Truss Hd. Screw
—	000 8169	10	5/16 - 18 Flanged Locknut

Dryer Roof (Optional)

Ref.	Part No.	Qty.	Description
1	128 2940	8	Roof Half Panel
2	128 2944	2	Side Top Hopper Panel
3	128 2748	4	Roof Side Gusset
4	128 4568	2	Level Auger Support
5	128 2941	4	Roof Panel Filler Half
6	128 2749	3	Roof Peak Gusset
—	000 8238	125	5/16 - 18 x 1/2" Capscrew
—	000 8169	125	5/16 x 18 Flanged Locknut

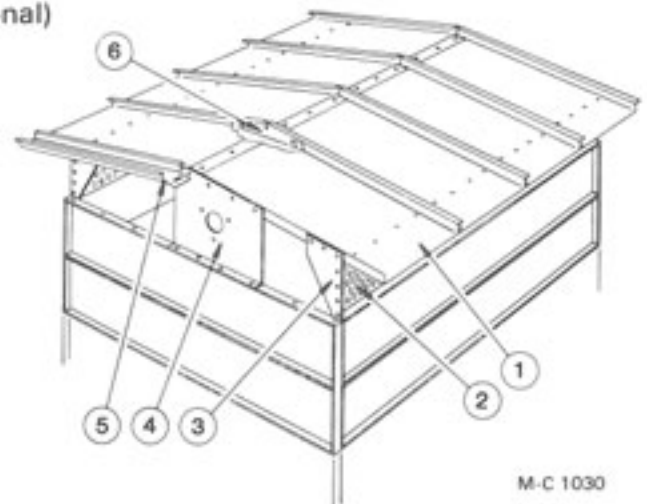

M-C 1030

Peak

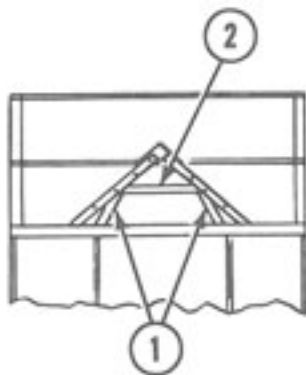
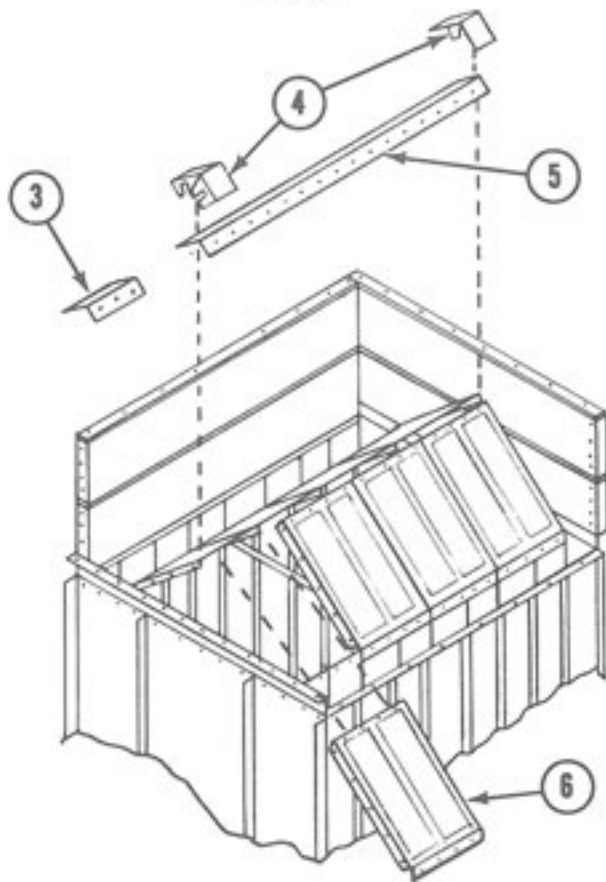

M-C 1031

Ref.	Part No.	Qty.	Description
1	128 2003	6	Support Angle - 29¼"
2	128 2012	3	Cross Tie - 31¼"
3	128 3075	1	Seal Angle
4	128 2908	2	Peak Seal Angle - Early Production (late production use ref. 3)
5	128 2991	1	Peak Cap
6	128 2891	8	Peak Panel - Perforated
	127 2834	8	Peak Panel - Solid
—	000 8104	64	5/16 - 18 x ¾" Truss Hd. Screw
	000 8106	50	5/16 - 18 x ¾" Capscrew
	000 8109	6	5/16 - 18 x 1¼" Capscrew
	000 8169	120	5/16 - 18 Flanged Locknut

Transformer and Cabinet (Used on 200V, 208V, 460V & 575V Dryers)

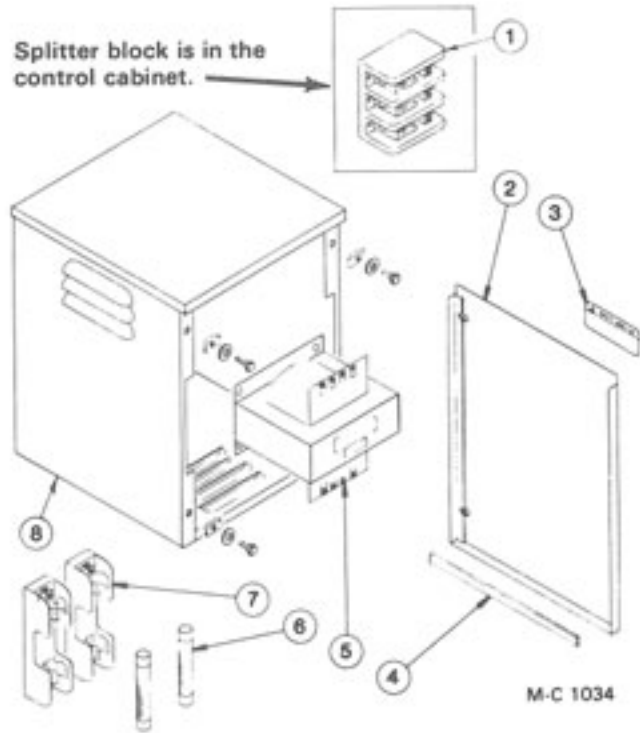

M-C 1034

Ref.	Part No.	Qty.	Description
1	128 6957	1	Splitter Block - 1 & 3 Phase
2	127 4881	1	Transformer Cabinet Door
	001 8111	4	5/16 - 18 Clip Nut
	128 8112	4	5/16" Flatwasher w/ Rubber Seal
	000 8108	4	5/16 - 18 x 1" Capscrew - Grd. 5
3	121 8316	1	Dryer Warning Decal
4	121 8966	—	Weather Stripping (Specify ft. reqd.)
5	127 6855	1	200/208V Transformer (750VA)
	127 6827	1	230/460V Transformer (750VA)
	127 6829	1	230/460/575V Transformer (750VA)
	001 8135	4	¾ - 16 x 1" Capscrew - Grd. 5
	000 8174	4	¾" Flatwasher
	000 8168	4	¾ - 16 Flanged Locknut
6	124 6835	2	208V Fuse - FRN9
	124 6829	2	460V Fuse - FRS4
	127 6839	2	575V Fuse - FRS3.2
7	121 6988	2	Fuse Holder (208, 460 & 575V)
8	127 0028	1	Transformer Cabinet

D260 Rev. 1, December 1990

Level Switch Assembly (Above S/N 46798)

Ref.	Part No.	Qty.	Description
—	128 6992	1	Bin Level Indicator Complete (Less ref. 3 thru 10)
	001 8201	4	¼ - 20 x 3" Capscrew
	000 8167	4	¼ - 20 Flanged Locknut
1	122 6850	1	Gasket
2	122 6849	1	Diaphragm (Teflon)
3	121 6969	1	Squeeze Connector - Straight
4	121 6920	12 ft.	Neoprene Cord - 18/2
5	121 6864	1	Female Terminal
6	125 6944	1	Piggy-Back Terminal
7	121 6915	1	Locknut - ½"
8	124 6887	1	Seal Ring - ½"
9	127 6849	1	Strain Relief - ½"
10	121 6866	2	Spade Terminal
11	122 6847	1	Spring
12	122 6848	1	Microswitch Ass'y.

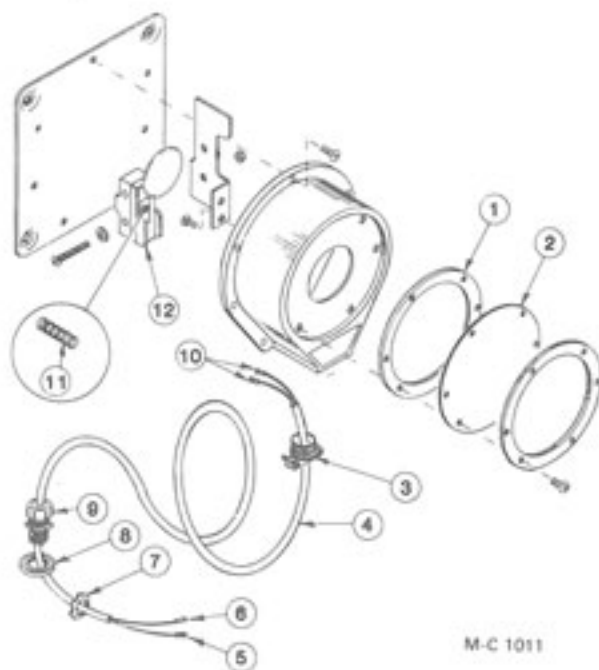

M-C 1011

Level Switch Assembly (Below S/N 46799 - see note)

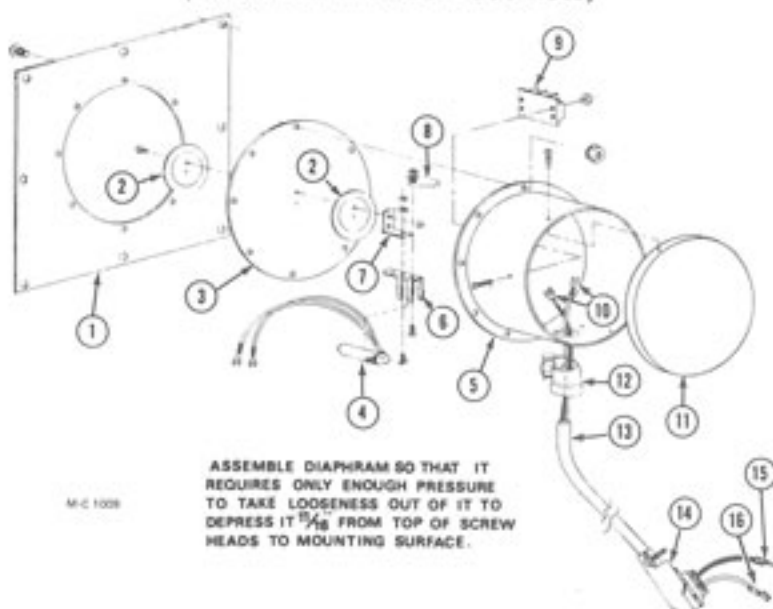

ASSEMBLE DIAPHRAM SO THAT IT
REQUIRES ONLY ENOUGH PRESSURE
TO TAKE LOOSENESS OUT OF IT TO
DEPRESS IT 1/8" FROM TOP OF SCREW
HEADS TO MOUNTING SURFACE.

M-C 1008

NOTE: The complete load switch is no longer available. It has been replaced with the level switch assembly shown above. Order kit 128 9029.

Ref.	Part No.	Qty.	Description
1	120 2833	1	Back Plate
2	120 5200	2	Mercury Switch Brkt. Washer
3	120 8996	1	Diaphragm
4	120 6800	1	Mercury Switch
5	120 5201	1	Housing
6	120 6801	1	Mercury Switch Clip

Ref.	Part No.	Qty.	Description
7	120 2946	1	Mount Bracket
8	125 4486	1	Level Switch Weight
9	120 6802	1	Terminal Strip
10	121 6866	2	Spade Terminal
11	120 7981	1	Cover
12	125 6901	1	Strain Relief
13	121 6920	12 ft.	18/2 Neoprene Cord
14	128 6833	1	½" - 90° Squeeze Connector
15	121 6864	1	Female Terminal
16	125 6944	1	Piggy-Back Terminal

Fan Motor and Magnetic Starter

MOTOR			MAGNETIC STARTER			
HP	*FLA	Part No.	Starter Part No.	Sq. "D" No.	Thermal Unit Part No.	Thermal Unit Size
200/208 V - 3 Phase - 60 HZ						
10	32.3	203 6809	128 6976	MO 33	128 6950	B 50
230 V - 1 Phase - 60 HZ						
10	45.0	124 6818	128 6976	MO 33	128 6953	B 79
230 V - 3 Phase - 60 HZ						
10	27.2	201 6818	128 6976	MO 33	120 6853	B 45
460 V - 3 Phase - 60 HZ						
10	13.6	201 6818	124 6880	KO 43	120 6855	B 25.0
575 V - 3 Phase - 60 HZ						
10	10.8	127 6857	124 6880	KO 43	128 6823	B 17.5

*If FLA (Full Load Amps) shown does not match FLA imprinted on motor name plate, refer to Square D charts for correct thermal unit size.

115V Coils and Interlocks

Starter		Coil		Interlock	
Sq. "D" No.	M-C No.	M-C No.	Sq. "D" No.	M-C No.	Sq. "D" No.
KO 43	124 6880	122 6832	C65108-400-40	128 6980	9999-R-20
MO 33	128 6976	122 6832	C65108-400-40	128 6980	9999-R-20

Jumper Strap Kits and Contact Kits

Starter		Jumper Strap Kit (2 straps per kit)		Contact Kit	
Sq. D No.	M-C No.	M-C No.	Sq. "D" No.	M-C No.	Sq. "D" No.
KO33	124 6880	120 6841	9998-SO31	122 6859	9998-LA37
KO43	124 6880	120 6841	9998-SO31	122 6855	9998-LA38
MO33	128 6976	120 6841	9998-SO31	122 6854	9998-LA57



Interlock
128 6980
(Type R-20)

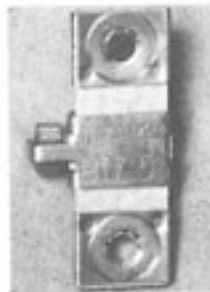

Thermal
Unit

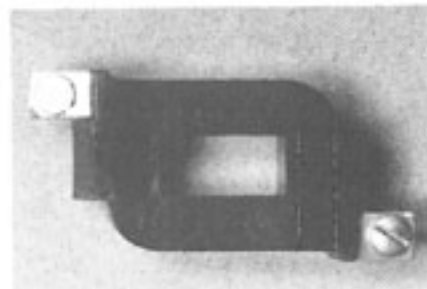

Magnetic Starter Coil

M.C. 1000

Portabilities

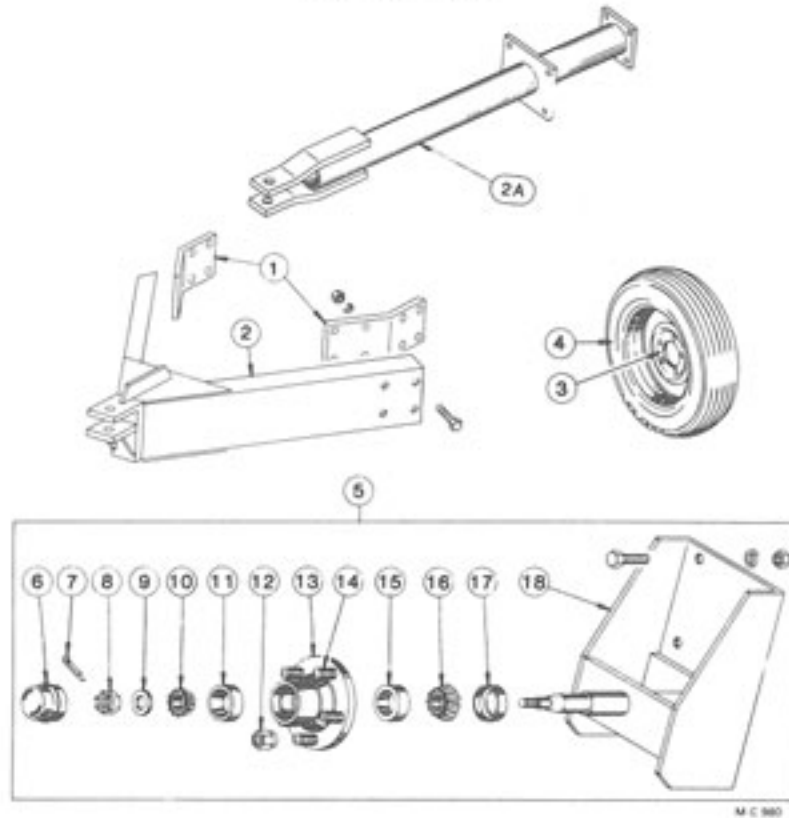

120 1037 - 2 Wheel Portabilities - Below S/N 43657 (Incl. ref. 2A and 2 of ref. 3 & 5 less tires)

120 1029 - 2 Wheel Portabilities - Above S/N 43656 (Incl. ref. 1 & 2 and 2 of ref. 3 & 5 less tires)

120 1040 - Additional Portabilities (Incl. two of ref. 3 & 5 less tires)

Ref.	Part No.	Qty.	Description	Ref.	Part No.	Qty.	Description
1	128 3671	2	Pole Mount Brkt. (Above S/N 43656)	5	120 1028	1	Wheel Spindle & Hub Ass'y. (Incl. ref. 6 thru 18)
	128 8196	8	3/4 - 10 x 2 1/2" Capscrew - Grd. 5		000 8146	6	5/8 - 11 x 1 1/2" Capscrew - Grd. 5
	000 8182	8	3/4" Lockwasher		000 8181	6	5/8" Lockwasher
	000 8165	8	3/4 - 10 Hex Nut		000 8164	6	5/8 - 11 Hex Nut
2	120 0047	1	Dryer Pole (Above S/N 43656)	6	001 8996	1	Hub Cap
	128 8195	8	3/4 - 10 x 2" Capscrew - Grd. 5	7	001 8252	1	Cotter Pin - 1/8" x 1"
	000 8182	8	3/4" Lockwasher	8	001 8253	1	Spindle Nut
	000 8165	8	3/4 - 10 Hex Nut	9	001 8254	1	Spindle Washer
2A	128 0128	1	Dryer Pole (Below S/N 43657)	10	001 6000	1	Bearing Cone - Outer
	000 8278	8	1/2 - 13 x 1 3/4" Capscrew - Grd. 5	11	002 6000	1	Bearing Cup - Outer
	000 8180	8	1/2" Lockwasher	12	001 8989	5	1/2 - 20 Lug Nut - 45°
	000 8163	8	1/2 - 13 Hex Nut	13	001 8992	1	Wheel Hub Ass'y. - 5 Bolt (Incl. ref. 11, 14 & 15)
3	001 8993	1	5 Bolt Wheel - 15"	14	002 8152	5	1/2 - 20 x 1 1/2" Stud
4	127 8990	1	7.60 x 15 - 6 Ply Tubeless Tire	15	002 6001	1	Bearing Cup - Inner
				16	001 6001	1	Bearing Cone - Inner
				17	001 8991	1	Seal
				18	120 0031	1	Wheel Mount

Repair Kits and Parts for Solenoid Valves, Modulating Valves and LP Gas Pressure Regulators

Solenoid Valve Repair Kits and Coils

IMPORTANT: To be sure that the correct repair kit or coil is being ordered, **ALWAYS** check the "ASCO" catalog number of the solenoid valve. The catalog number is stamped on the name plate located on the top of the solenoid valve (See illustration on Page 37) or on the decal on the side of the valve. Then, locate the "ASCO" catalog number in the listing below to find the M-C part number of the repair kit or coil required.

Solenoid Valve		Repair Kit		Coil	
M-C Part No.	ASCO Catalog No.	M-C Part No.	ASCO Part No.	M-C Part No.	ASCO Part No.
1/2" Solenoid Valves					
125 7082 (1/2" - 115V)	†8210-106-B	122 7039	K306-632	122 7001	64-982-4D
125 7082 (1/2" - 115V)	*HVA174-919-24	122 7039	K306-632	122 7001	64-982-4D
123 6890 (1/2" - 12V-DC)	*HVA174-919-24-12V	122 7030	210-412	122 7024	27-463-3
3/4" Solenoid Valves					
--- 4610 (3/4" - 115V)	*8210B26	122 7033	302-278	--- 4607	98-817-1
121 7002 (3/4" - 115V)	*8210B95	122 7041	158-927	122 7001	64-982-4D
121 7002 (3/4" - 115V)	*8210C95	122 7005	158-929	122 7001	64-982-4D
123 8251 (3/4" - 115V)	*8210D3B	122 7031	304-091	122 7011	99-216-1
121 7002 (3/4" - 115V)	*8210D95	122 7005	158-929	122 7001	64-982-4D
121 7025 (3/4" - 12V-DC)	†8215B30	122 7029	K302-430	122 7024	27-463-3
121 7002 (3/4" - 115V) (See IMPORTANT)	*8215B30B	122 7028	182-466	122 7001	64-982-4D
121 7002 (3/4" - 115V) (See IMPORTANT)	†8215C30B	122 7035	K304-089	122-7001	64-982-4D
1" Solenoid Valves					
123 7000 (1" - 115V)	*8210D8	122 7025	K302-280	122 7011	99-216-1
128 7000 (1" - 12V-DC)	*8215A60	122 7032	103-229	122 7027	96-671-4
127 7001 (1" - 12V-DC)	†8215B60	122 7038	K302-432	122 7037	62-691-1LB
128 7001 (1" - 115V)	†8215B60	122 7034	K302-352	--- 4607	96-817-1

†Current *Obsolete

IMPORTANT: The bodies and internal parts of "ASCO" Model 8215B30B and 8215C30B solenoid valves are **NOT** interchangeable. A different repair kit is available for each model. Serious problems may result if the wrong

D260 Rev. 1, December 1990

Repair Kits and Parts for Solenoid Valves, Modulating Valves and LP Gas Pressure Regulators

repair kit is installed. If the complete valve is to be replaced, **ALWAYS** replace the **ENTIRE** valve including the body.

Kit 122 7028 is to be used in the **Model 8215B30B valve only**. If this kit (or an entire 8215B30B valve, less the body) is installed in a Model 8215C30B body the result would be little or no opening for gas flow.

Kit 122 7035 is to be used in the **Model 8215C30B valve only**. If this kit (or an entire 8215C30B valve, less the body) is installed in a Model 8215B30B body the diaphragm will not reach the body seat and the valve would probably **NOT CLOSE** when de-energized.

Modulating Valves

For 1/2" Modulating Valves 121 7012 & 121 7024

122 9992 - Seat Kit (Incl. stem, disc holder and diaphragm)

122 7009 - Diaphragm Kit

For 1 1/4" Modulating Valves 123 7002 & 123 7024

122 9993 - Seat Kit (Incl. stem, disc holder and diaphragm)

122 7006 - Diaphragm Kit

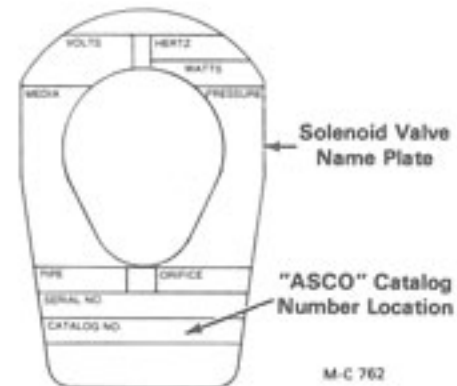

LP Gas Pressure Regulators

For Regulator 121 7006 (Rego 1586YN)

122 8908 - Stem and Seat Disc Kit

122 9000 - Repair Kit (Incl. diaphragm, stem and seat disc)

For Regulator 121 7006 (Fisher 620/5810)

122 7004 - Diaphragm

122 7016 - Disc Holder and Disc

122 7017 - Red Spring

122 8607 - Snap Ring (2 reqd.)

122 8608 - Body Gasket

For Regulator 128 7005 (Fisher 627/5810)

122 7043 - Diaphragm (Nitrile)

122 7044 - Disc Assembly

122 7045 - Control Spring (Yellow)

122 7046 - Stabilizer

122 7047 - Diaphragm Case O Ring

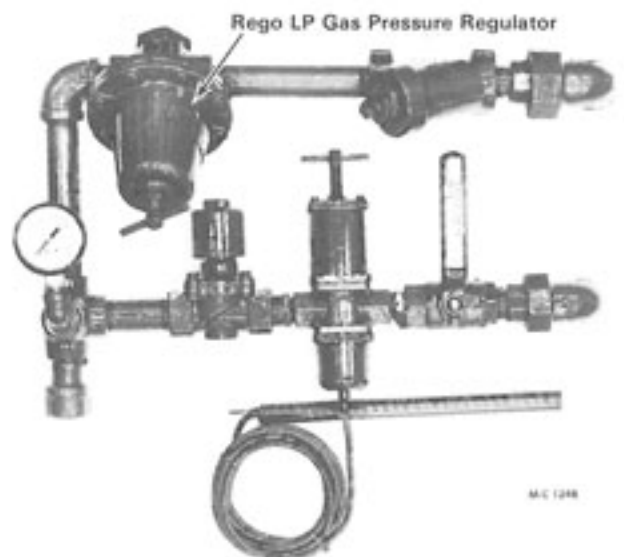

Fisher LP Gas Pressure Regulators



121 7006



128 7005

M-C 1218

10" Unloading Auger Extension Kit (2') - 127 1181

(Above S/N 47163)

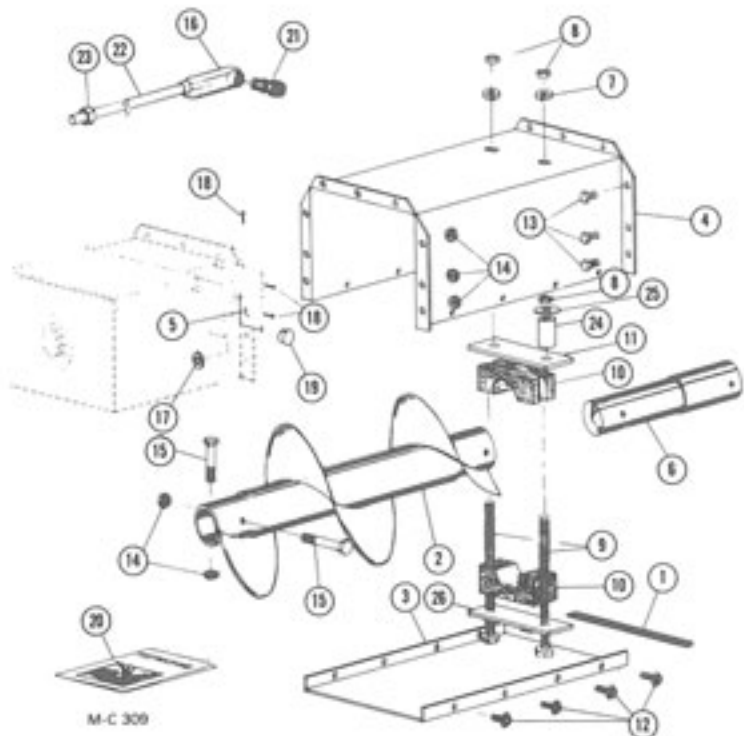

Old Bearing Mounting

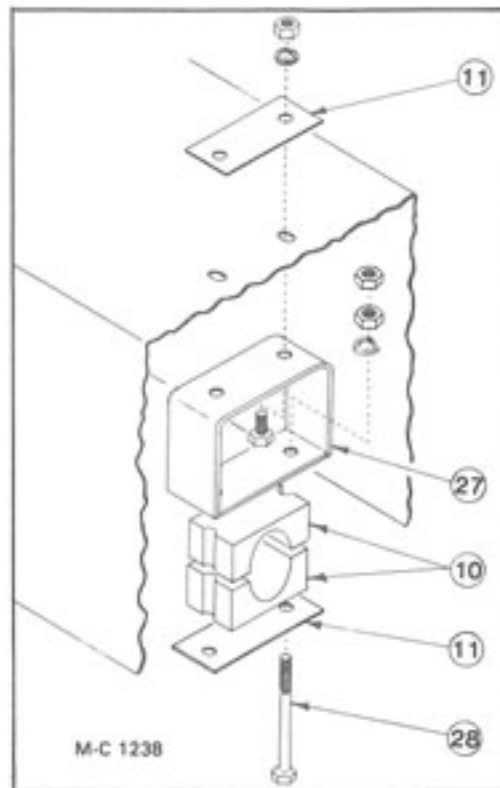

New Bearing Mounting

NOTE: Two types of bearing mounting were used. Order bearing mounting parts as required. Kit 127 1181 includes new bearing mounting parts.

Ref.	Part No.	Qty.	Description
1	121 8957	1	Rubber Guard Edge
2	127 0029	1	Unload Auger Extension
3	127 4436	1	Auger Cover - Bottom
4	127 4435	1	Unload Auger Cover
5	127 4786	1	Switch Cover - Back
6	127 5081	1	Unload Auger Link
7	000 8180	2	½" Lockwasher (Late Kits)
8	000 8163	4	½ - 13 Hex Nut
9	041 8160	2	½ - 13 x 8" Capscrew - Grd. 8 (Full Thread)
10	128 6020	1	1-15/16" Wood Bearing
11	128 4250	2	Mid Bearing Support
12	001 8284	8	5/16 - 12 x ½" Self Tapping Screw
13	000 8119	9	¾ - 16 x ¾" Capscrew
14	000 8205	15	¾ - 16 Top Lock Flange Nut
15	000 8229	6	¾ - 16 x 2¼" Capscrew - Grd. 5
16	125 6915	1	½" LR 50A Condulet
17	000 8174	1	¾" Flatwasher
18	000 8184	3	8 - 18 x ½" Phillips Pan Head Screw

Ref.	Part No.	Qty.	Description
19	121 8600	1	½" Knock-Out Plug
20	D151	1	Installation Instructions
21	121 6892	2	½" Straight Connector
22	120 6865	1	½" Conduit (30" Long)
23	121 6895	1	½" Conduit Union
24	128 5572	2	Spacer - 3¾"
25	001 8257	2	½" SAE Flatwasher
26	128 0285	1	Bearing Support
27	128 0288	1	Bearing Bracket
	133 8161	2	½ - 13 x 1½" Capscrew - Grd. 5
	000 8180	2	½" Lockwasher
	000 8163	2	½ - 13 Hex Nut
28	001 8168	2	½ - 13 x 4½" Capscrew - Grd. 5
	000 8180	2	½" Lockwasher
	000 8163	4	½ - 13 Hex Nut
—	121 6868	2	Closed End Splice
—	128 6925	2	Female Insulator
—	121 6930	8 ft.	18 Ga. Black Wire

D260 Rev. 1, December 1990

Kits (Field Installed)

All Heat Conversion Kits - For Below S/N 34284

- 127 9062 - LP Gas
- 127 9063 - Natural Gas

Decal Kit

- 128 9024

Electrode Kit, Style 2 - For Below S/N 43657

- 127 9183

Gas Conversion Kits

- 127 9064 - LP Gas to Natural Gas
- 127 9187 - Natural Gas to LP Gas

Heat Bulb Kit - For Below S/N 43657 (Not for B12)

- 128 9012

Ignition Wire Kits

- 122 9004 - For Style 1 Electrode (Not for B12)
- 122 9003 - For Style 2 Electrode (Not for B12)

Rear Discharge Switch Kit - For Below S/N 43657

(Not for B12)

- 128 9011

Remote Sensing Kit - For Below S/N 47164

- 128 9026

Remote Sensing Wire Kit

- 122 9003

Unload Auger Extension Kit (2 ft.) - For Above S/N 47163

- 127 1181



Iron Horse Quality